



# SUMMIT SERIES® II 650 W



## NEW FEATURE



Want to know more about Sigma? Contact a Lester sales representative today.



The Summit Series® II charger family is a cornerstone of Lester Electrical's motive power charging portfolio. Offering advanced communication capabilities, flexible battery compatibility, and rugged industrial performance, Summit Series® II chargers are well suited for golf cars, aerial work platforms, material handling equipment, floor care machines, and other demanding applications.

AVAILABLE MODELS			
48V / 13.5A	36V / 18A	24V / 25A	36-48V / 18-13.5A
29700	29900	29300	30600

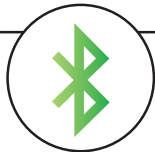

## BLUETOOTH®

Featuring Bluetooth wireless communication with apps for Apple® and Android™ phones and tablets. View charge cycle status, select the active battery profile, upload new profiles, change between on-board and off-board and download charge history records anytime using just a smart phone or tablet.



## PERFORMANCE

Our Summit Series® II provides industry-leading charging performance and intelligence. Our proprietary Progressive DV/DT™ charge algorithm ensures a precisely charged battery every time. The chargers are tested in extreme temperatures and operating conditions and built to last.



## EFFICIENCY

Our switch mode (high frequency) chargers have best-in-class efficiency and are compliant with the latest DOE, CEC, and NRCAN standards. We operate a CEC approved laboratory in our Lincoln, NE manufacturing plant.

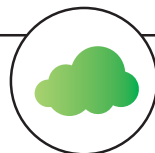

## CLOUD CONNECTIVITY

Push charge histories to the cloud to access data anywhere in the world. Enjoy expert technical support as our Lester Electrical staff can quickly see historical charging records. Add new charging profiles to your charger by pulling from the cloud and pushing to your charger.



## EXPERTISE

Lester has been designing and manufacturing industrial battery chargers for more than sixty years. We are an employee owned company and every member of our team is invested in the quality we deliver our customers.



## FLEXIBILITY

Universal AC input and external DC and signal connections allow for easy customization and worldwide use. Our 650W offers multi-voltage support allowing one charger to operate at 36V or 48V.

# SPECIFICATIONS

## AC INPUT

<b>Voltage range, rated</b>	100-240 Vac
<b>Voltage range, operating</b>	85-265 Vac ( $< 108$ Vac: reduced power)
<b>Frequency, rated</b>	50-60 Hz
<b>Frequency, operating</b>	45-65 Hz
<b>Phase</b>	Single-phase
<b>Current, maximum</b>	$< 8$ A
<b>Efficiency</b>	$> 90\%$ peak, DOE test procedure, 115 Vac, AC and DC losses included
<b>Protection</b>	Current limit, surge, transient, under voltage, over voltage

## DC OUTPUT

<b>Power</b>	650 W		
<b>Voltage, nominal</b>	24 Vdc	36 Vdc	48 Vdc
<b>Voltage, maximum</b>	36 Vdc	54 Vdc	72 Vdc
<b>Current, maximum</b>	25 A	18 A	13.5 A
<b>Voltage, min start-up</b>	10 Vdc		
<b>Battery types</b>	Lead-acid (Wet / AGM / Gel), lithium, custom		
<b>Protection</b>	Current limit, short circuit, reverse polarity, under voltage, over voltage, wrong battery voltage		

## ENVIRONMENTAL

<b>Enclosure rating</b>	IP66, NEMA 4
<b>Operating temperature</b>	$-25^{\circ}\text{C}$ to $60^{\circ}\text{C}$ ( $-13^{\circ}\text{F}$ to $140^{\circ}\text{F}$ )
<b>Storage temperature</b>	$-40^{\circ}\text{C}$ to $85^{\circ}\text{C}$ ( $-40^{\circ}\text{F}$ to $185^{\circ}\text{F}$ )

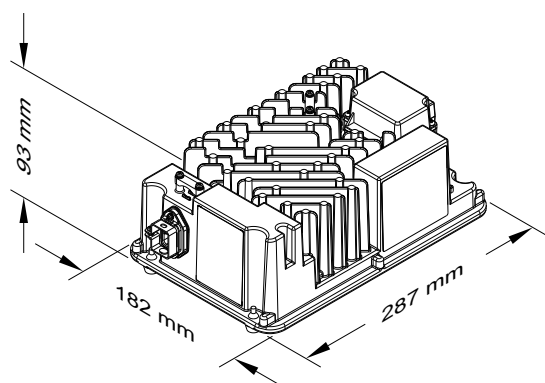

## USER & VEHICLE INTERFACES

<b>Bluetooth Wireless</b>	Apps for Apple and Android phones and tablets
<b>LEDs</b>	Charge Complete (green), Charge Status (yellow), AC Present (blue), Fault (red)
<b>Remote LED</b>	Single tri-color; charge complete, charge status, fault; output standard; LED assembly optional
<b>Lockout / interlock</b>	Single wire
<b>Battery temperature</b>	Input standard; sensor optional
<b>CAN bus communication</b>	CANopen® and SAE J1939 standard, contact LE sales regarding customized options

## MECHANICAL

<b>Dimensions (LxWxH),</b> <i>(removable feet not included)</i>	287 x 182 x 93 mm (11.297 x 7.171 x 3.641 in)
<b>Weight</b>	8.430 lbs (3.824 Kgs)
<b>Cooling</b>	Natural convection (no fan)
<b>AC input connector</b>	IEC 60320 C16 inlet with cord clamp
<b>DC output connector</b>	External terminals with cover
<b>Lockout connector</b>	External terminal with cover
<b>Battery temp connector</b>	External terminal with cover
<b>Remote LED connector</b>	External DB9 (DE9)
<b>CAN bus connector</b>	External DB9 (DE9)
<b>Mounting</b>	Shelf, wall, bulkhead, threaded rod, hook
<b>Handle</b>	Carrying handle optional

## SAFETY/REGULATORY

<b>Efficiency</b>	DOE Code of Federal Regulations, CEC Appliance Efficiency Regulations, Title 20; 10 CFR Part 430, NRCAN Energy Efficiency Regulations
<b>Safety / Emissions</b>	UL recognized/listed; cUL certified; FCC Part 15; ICES-003; EN safety, emissions, immunity; CE Certified; ACMA RCM (C-Tick)



Specifications are subject to change without notice. Copyright Lester Electrical of Nebraska, Inc. All rights reserved.

The Bluetooth® word mark and logos are registered trademarks owned by Bluetooth SIG, Inc., and any use of such marks by Lester Electrical is under license. Other trademarks and trade names are those of their respective owners.

Apple is a trademark of Apple Inc., registered in the U.S. and other countries. App Store is a service mark of Apple Inc., registered in the U.S. and other countries.

Android is a trademark of Google Inc. Google Play and the Google Play logo are trademarks of Google Inc.

CANopen® is a registered trademark of CAN in Automation in Europe.

**WEBSITE:** [www.LesterElectrical.com](http://www.LesterElectrical.com)

**PHONE:** (402) 477-8988

**E-MAIL:** [APodwinski@LesterElectrical.com](mailto:APodwinski@LesterElectrical.com)  
[JillA@LesterElectrical.com](mailto:JillA@LesterElectrical.com)

Lester Electrical  
625 West A Street, Lincoln, NE 68522, USA