

# MICA

---



# General information



## Features

- Multifunction touch button.
- Customizable status light ring.
- USB type C connector.
- Wi-Fi Connectivity.\*

## Dimensions and weight

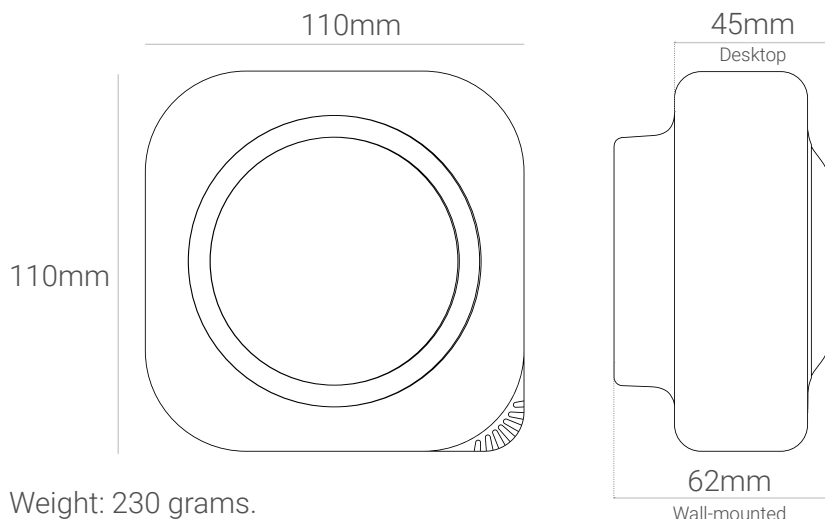

Weight: 230 grams.

## Installation options

- Desktop.
- Wall-mounted (cable gut).
- Wall-mounted (electrical box).

## Power supply options \*\*

- 110 - 240V AC 50-60 Hz 0.2A.
- 8 - 36V DC 2A 10W.
- RJ45 PoE 54VDC 12.95W (802.3af and above).
- USB type C 5VDC 2A (for desktop only).

## Other connectivity options \*\*

- LoRaWAN 868 MHz.
- LoRaWAN 915 MHz.
- NB-IoT / LTE-M.
- Sigfox 868 MHz.
- Sigfox 915 MHz.
- Ethernet.

## Local communication options \*\*

- Modbus RTU (RS-485) & TCP/IP (wireless).
- BACnet IP.

\* The device can only connect to 2.4 GHz WiFi networks with 802.11 b/g/n (802.11n up to 150 Mbps) protocols. Supported authentication and security protocols: WPA2 (Personal), WPA2 Enterprise, WPA3 (Personal), and WPA3 Enterprise.

\*\* Power Supply, connectivity (other than Wi-Fi), and local communication options or extra sensors must be specified and requested by the customer.



## Sensors

### Temperature

Sensor: Silicon bandgap / Unit: °C  
Range: -40 - 125 °C / Resolution: 0,1 °C  
Accuracy: ± 0,5 °C  
Lifespan<sup>1</sup>: >10 years

### Relative Humidity

Sensor: Capacitive / Unit: %RH  
Range: 0 - 100 %RH / Resolution: 1 %RH  
Accuracy: ± 2 %RH  
Lifespan: >10 years

### CO<sub>2</sub>

Sensor: NDIR / Unit: ppm  
Range: 400 - 10.000 ppm / Resolution: 1ppm  
Accuracy: ±(30 + 3% m.v.) ppm  
Lifespan: >10 years

### TVOC

Sensor: MOx / Unit: VOC Index Points (µg/m<sup>3</sup> / ppb)\*  
Range: 0 - 500 VOC Index Points (0 - 1000 ppm) / Resolution: 1 VOC Index Points  
Accuracy: ±15 VOC Index points or ±15% m.v., whichever is larger  
Lifespan: >10 years

### PM<sub>2,5</sub>

Sensor: Particle laser / Unit: µg/m<sup>3</sup>  
Range: 0 - 1.000 µg/m<sup>3</sup> / Resolution: 1 µg/m<sup>3</sup>  
Accuracy: ± (5 µg/m<sup>3</sup> + 5% m.v.) (0 -100 µg/m<sup>3</sup>), ±10% m.v. (101-1000 µg/m<sup>3</sup>)  
Lifespan: >10 years

### PM<sub>10</sub>

Sensor: Particle laser / Unit: µg/m<sup>3</sup>  
Range: 0 - 1.000 µg/m<sup>3</sup>/ Resolution: 1 µg/m<sup>3</sup>  
Accuracy: ±25 µg/m<sup>3</sup> (0 -100 µg/m<sup>3</sup>), ±25% m.v. (101 - 1000 µg/m<sup>3</sup>)  
Lifespan<sup>1</sup>: >10 years

[1] Lifespan is based on the average lifetime of the sensor, at which the specified accuracy is guaranteed. After the indicated years, it is recommended to replace the sensor to guarantee the accuracy of the measurement.

\* The measurements can be displayed in either relative Index Points values (recommended) or in µg/m<sup>3</sup> or ppb concentrations. You can select the option that best suits you from My inBiot. [More information.](#)

## *Additional sensors*

### Noise

Sensor: MEMS Microphone / Unit: dB  
Range: 30 - 120 dB / Resolution: 1 dB  
Accuracy:  $\pm 5$  dB

## *Indicators*

### Indoor Air Quality [↗](#)

Range: 0 - 100 index point  
Resolution: 1 index point

### Thermohygrometric Comfort [↗](#)

Range: 0 - 100 index point  
Resolution: 1 index point

### Resistance to Mold Growth [↗](#)

Range: 0 - 100 index point  
Resolution: 1 index point

### Resistance to Virus Spread [↗](#)

Range: 0 - 100 index point  
Resolution: 1 index point

### Ventilation Efficiency [↗](#)

Range: 0 - 100 index point  
Resolution: 1 index point

# Use notes



1. To install and configure your MICA, please refer to [repository](#) on our website.

---

2. Authorized Accessories: To ensure proper performance and device safety, use only inBiot-supplied cables and power adapters. inBiot is not responsible for any malfunction, damage, or loss of warranty resulting from the use of non-compliant accessories.

---

3. Some sensors require preheating so they may not display data for the first few minutes or hours after powering up.

---

4. During the first 24 hours after connecting the MICA, ensure that clean ambient air concentration values are reached through proper ventilation to ensure optimal initial calibration.

---

5. Maintain sufficient ventilation periodically to ensure sensor performance, as some operate with auto-calibration algorithms.

---

6. The CO<sub>2</sub> calibration cycle is 48 hours by default. If you wish to change it, access the “calibration” section of the [inBiot Setup App](#).

---

7. Recommended operating conditions: 10 - 40°C and 20 - 80%RH. Maximum operating conditions: -10 - 50°C and 0 - 90%RH.

---

8. MICA devices ventilate both through the sides and through the air intake located at the back, so it is essential not to cover them to ensure correct sensor measurements.

---

9. MICA devices should not be installed in air ducts or in areas exposed to drafts with high air flow rates, as this may affect its performance, accuracy and lifetime.

---

10. MICA devices should not be installed in locations exposed to direct sunlight or near heat sources, as measurements may be affected.

---

11. Refrain from manipulating or using unofficial spare parts for device repair or maintenance. Any attempt to do so will result in the automatic loss of device warranty.

---

12. The MICA is designed for indoor air quality monitoring. Outdoor use is under the customer’s responsibility and any damage resulting from such use will invalidate the warranty.

---

13. Avoid installing MICA in indoor spaces with continuous relative humidity above 85% without condensation, as it could cause irreparable damage to the device.

---

14. For any further questions, please contact us using the form available on inBiot’s [support page](#).

