



RPL-X-Series

High Performance Pressure Regulator

The RPL-X-Series regulators (also known as XHPR) are self-venting high precision pressure regulators with excellent performance; compatible with all common water and oil based hydraulic fluids.

Features:

- Controlling pressures up to 900 bar
- Up to 300 bar differential pressure
- Patented, unique pressure sensing technology for high precision
- Excellent durability and repeatability
- Progressive gear secure low torque on adjustment wheel over entire range
- Valve details in coated Ti gr.5
- In compliance with ATEX Directive 2014/34/EU, Marking: II 2 G Ex h IIC T6 Gb

Applications:

- Work over control systems
- Hydraulic Power Units
- Liquid Sampling

Description:

RPL-X14 and RPL-X21 are high-performance pressure regulators with a patented pressure sensor system that ensures precise pressure control and high capacity throughout the control area. The regulator are compatible with all common water and oil based hydraulic fluids and secure low maintenance and life-cycle cost. As an option RPL-X-series can be delivered with actuator for remote operation.

Specifications / Designations RPL-X14 (XHPR-14):

Model designations	Operational mode:	Material pressure housing	Max inlet pressure [barg]	Controlled pressure range [barg]	Filter options	Gasket	Inlet/Outlet ports	Nom. / max intermittent flow [l/min]
RPL-X14	M or F	S or D	T or L	Pxxx	IF or NF	H	A3	(not used)
	Manually or Fixed	S = 316	T = 925	50 - P370	Internal Filter or No Filter	H = HNBR	A3 = AE MP 3/8"	10 / 25
		S = 316	T = 925	50 - P690				10 / 25
		S = 316	V = 950	50 - P720				10 / 25
		D = Duplex	L = 1035	50 - P900				5 / 8

Specifications / Designations RPL-X21:

Model designations	Operational mode:	Material pressure housing	Max inlet pressure [barg]	Controlled pressure range [barg]	Filter options	Gasket	Inlet/Outlet ports	Nom. / max intermittent flow [l/min]
RPL-X21	M or F	S or D	T or L	Pxxx	IF or NF	H	A4	(not used)
	Manually or Fixed	S = 316	T = 925	50 - P370	Internal Filter or No Filter	H = HNBR	A4 = AE MP 9/16"	10 / 25
		S = 316	T = 925	50 - P690				10 / 25
		S = 316	V = 950	50 - P720				10 / 25
		D = Duplex	L = 1035	50 - P900				5 / 8

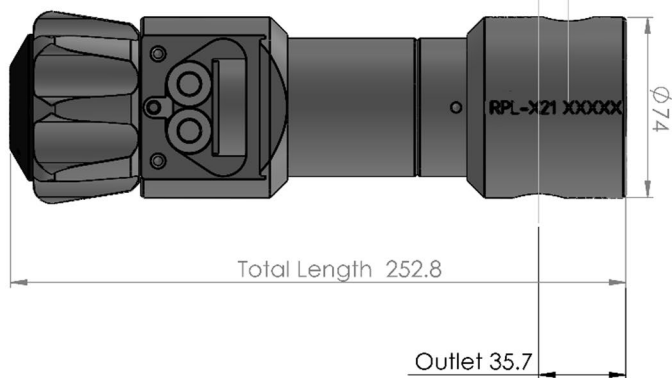
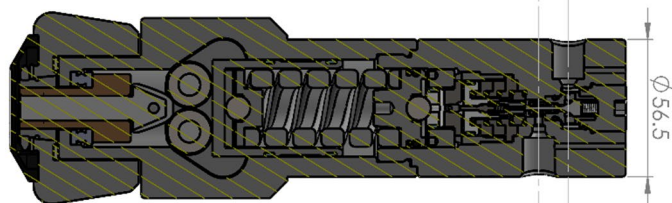
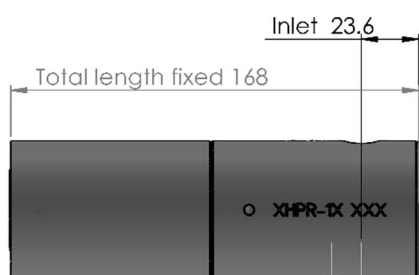

Manually operated or fixed versions

For manually operation: Adjustment wheel with a progressive gear. 6 off roller bearings and a wedge keep the manual torque on adjustment wheel easy to handle.

RPL-X14 Fixed: 2,9 kg

RPL-X14 Weight: 4,9 kg

RPL-X21 Fixed: 3,7 kg

RPL-X21 Weight: 5,7 kg

For the fixed set-pressure version the pressure housing and internals are identical. Main dimensions and weight are:

- Length 168 mm, outer diameter ϕ 56,5 mm
- Weight: 2,9 kg

Common features all model designations:

- All gaskets in HNBR
- Max ΔP = pressure is 300 bar for nominal flow
- Cv value at fully open inlet valve is about 0,2
- Tubing size 3/8" Medium Pressure
- Inlet valve: Hard coated Titanium gr. 5 for increased durability
- Vent port: 1/8" BSP
- An O-ring stack is acting as a flexible chamber for the patented pressure sensing system

Different compression springs are used depending on the requested pressure range (model /type)