

.67

RESUME PORTFOLIO

个人作品集

动效作品链接: <https://bento.me/luqi67>

zhengluqi

浙江海洋大学-航海技术 本科·1992.9

追波链接: <https://dribbble.com/mitty>

工作经历

 悠树智能 2022.3-至今 UI/UX设计师

负责跨境支付产品Sass工具 Dashboard的改版及界面优化, 日常需求

负责Wooshpay收银工具, 官网的风格设定及视觉交互的优化
负责公司所有设计工作包括动效, 3D, 运营等



腾讯音乐-广州酷狗音乐 2020.7-2021.12 高级UI设计师

推动酷狗音乐竖屏MV功能的改版和1+的功能设计

负责竖屏MV 弹幕, 负一屏, 等1+功能的设计

负责酷狗竖屏mv/视频设计改版模块化设计, 独立APP 0-1项目
同时负责项目中UI动效的设计和运营视觉设计

联系电话: 13123910671

邮箱: 15088702405@163.com



蚂蚁金服 (驻场外包) 2019.2-2020.3

负责支付宝小程序UI界面设计

参与支小镇2.5D插画设计

负责财富频道蚂蚁形象动效设计提供动效解决方案



浙江执御信息技术有限公司 2017.5-2019.1

负责电商app安卓端设计, 参与其组件化0-1的设定和设计.

负责团队内 0-1 项目 支付产品JollyPay APP, 短视频APP TOPV

推动优化Jollychic 品牌升级的宣发视频制作.

担任团队UI动效设计师角色, 为团队提供动效设计解决方案.



杭州多麦 2014.6-2017.3

负责电商APP 海蜜全球购APP UI/视觉设计

| +

K 酷狗音乐 | 竖屏MV

体验升级 • 趣味玩法 • 用户导流 •

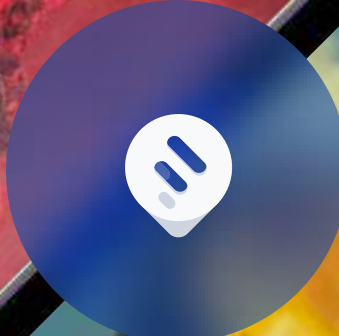
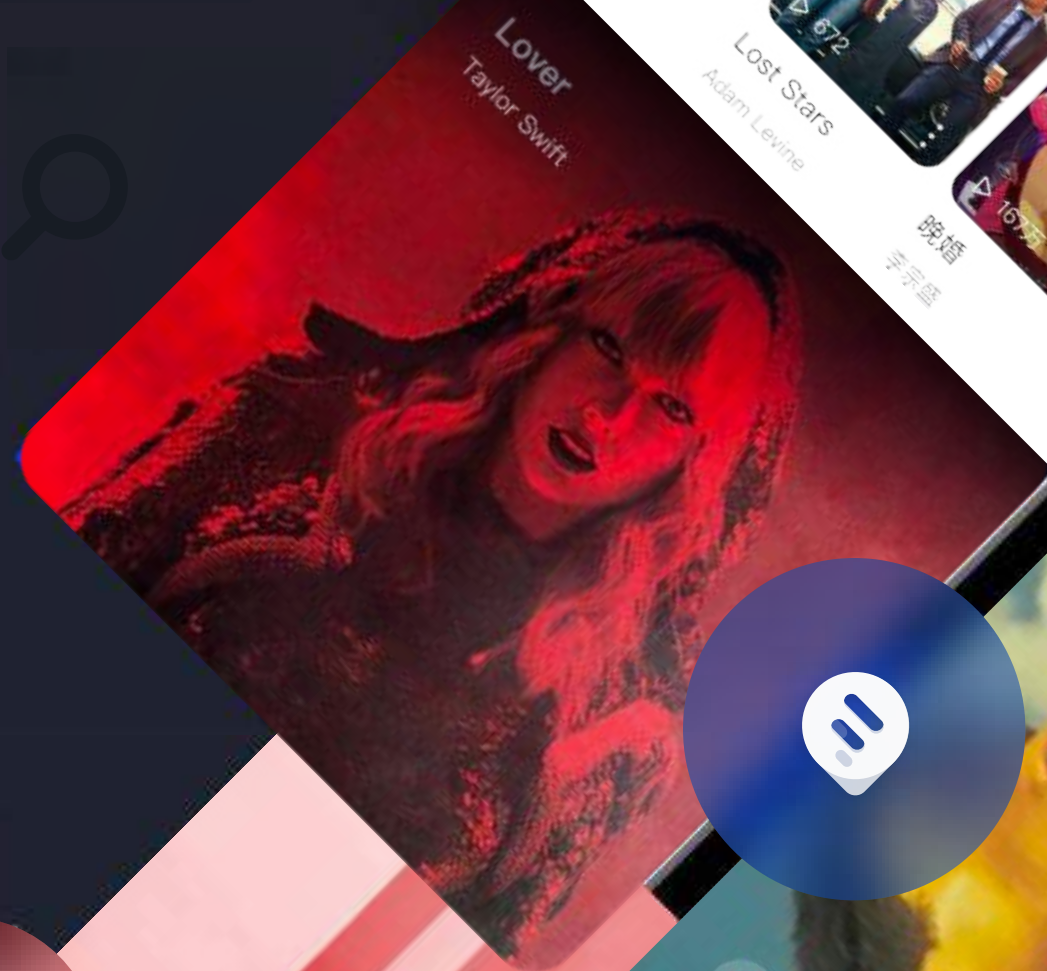
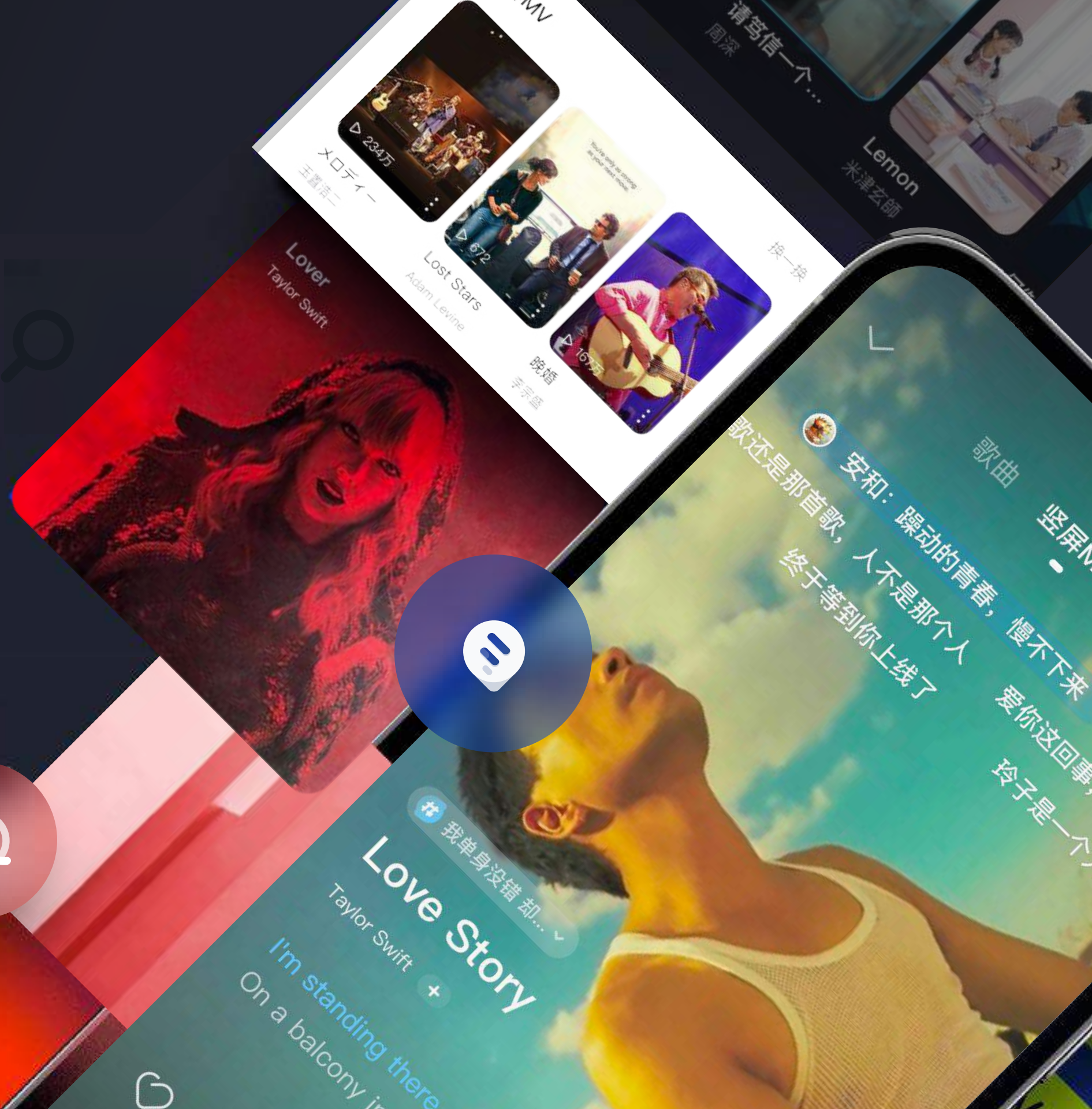

我单身没错 却...
Love Story
Taylor Swift +
I'm standing there
On a balcony in...

歌曲 竖屏MV
安和：躁动的青春，慢不下来
还是那首歌，人不是那个人
终于等到你上线了
爱你这事儿，玲子是一个



| + 趣味玩法

互动 全景 播单 长音屏 运营位

🎵 弹幕功能设计

🎬 负一屏

🎧 歌词沉静式

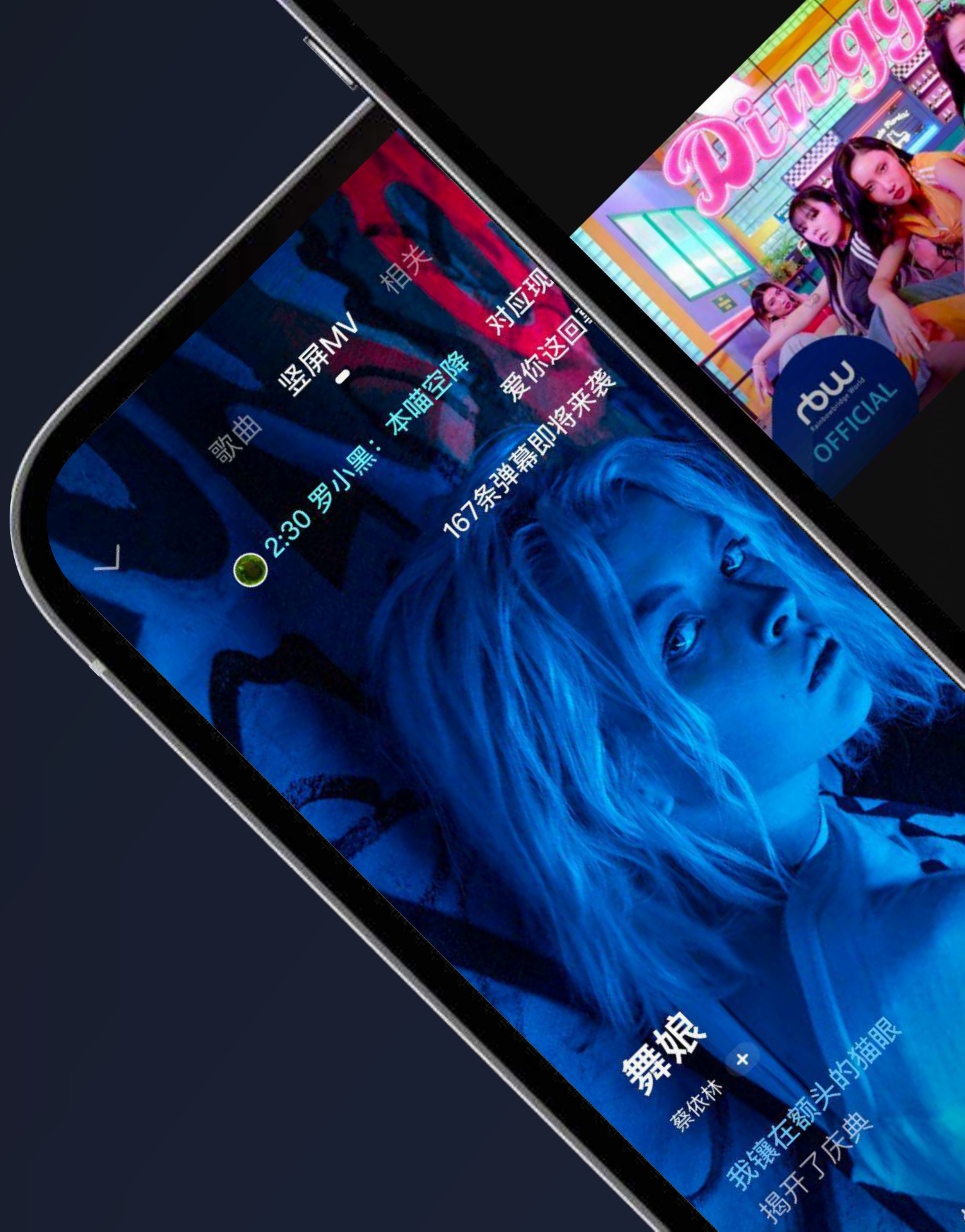

弹幕功能设计

需求解析-画像竞品分析-结论设计-结果回收

设计策略

目的:增加弹幕, 情感功能



用户群像

通过用户类型,寻找竞品,寻找机会点

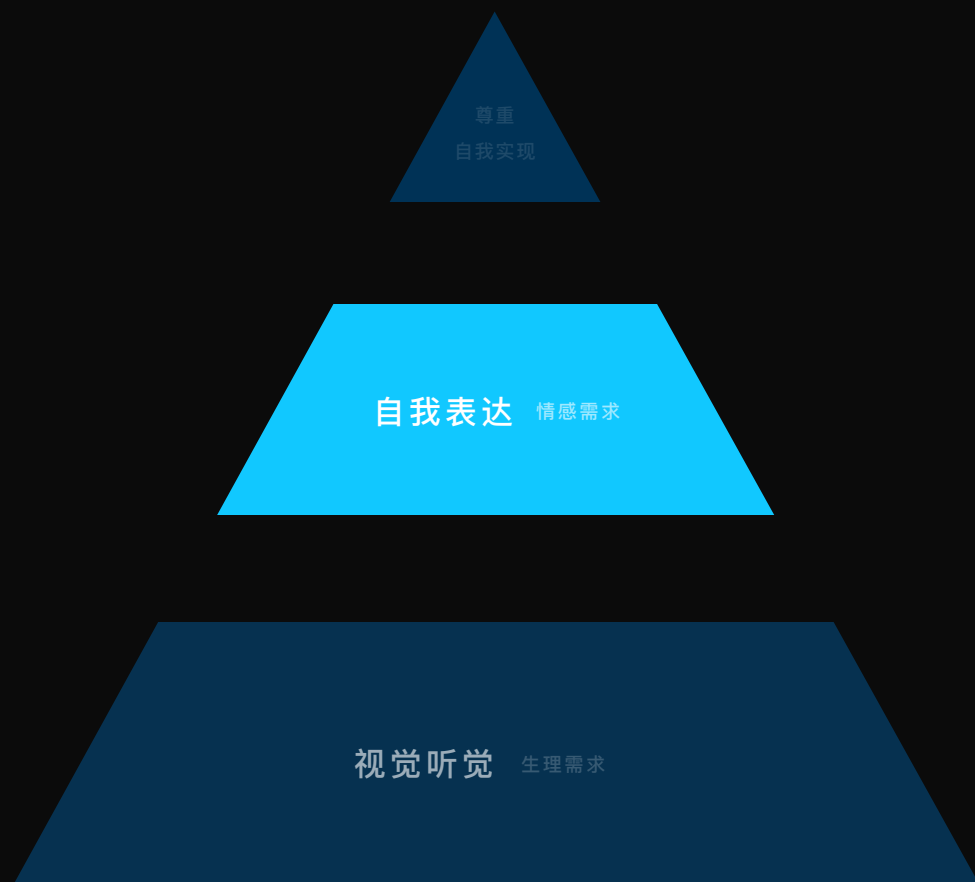

需求思考

需求思考

在做弹幕之前也尝试过评论的形式作为主要情感表达方式

- 歌曲页已有评论用户容易混淆，视频内容不够优质很难激起用户发表评论
- 弹幕的轻量级和梗的理念更能激起用户情感表达
- 需要重新搭建评论体系

疑问：需要怎样的弹幕，弹幕的位置和视觉又如何

用户画像

对我们的用户有印象，从用户喜欢的app中寻找灵感

18以下

18-23

00后

24-30

90后

30+

中青年

竞品选择

通过参考各个竞品的弹幕功能细节，设计适合竖屏mv的弹幕样式



网易云

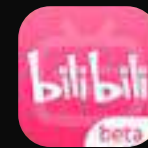

bilibili



爱优腾

用户画像

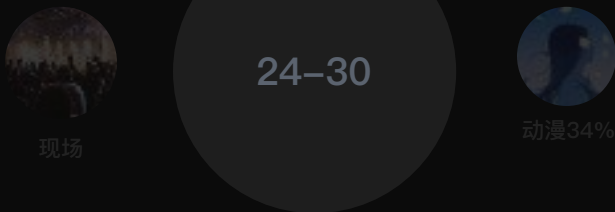

竞品筛选

音乐,视频,90,00后

竞品分析



B站

- 全屏展示 (可调整展示区域)
- 样式多, 玩法多样, 甚至可以作为内容展示
- B站独特文化影响, 弹幕可看性高



网易云

- 弹幕精简, 对内容无干扰
- 和评论合并, 看大与玩
- 评论梗多, 常有歌手彩蛋出没



爱优腾

- 彩色弹幕, 弹幕边框, 弹幕头像等玩法多样
- 爱奇艺有快捷词, 能够快速发弹幕
- IP头像和内容强相关

设计机会点



落地/验证

视觉感知提升



设定弹幕位置和间距

从视觉角度设定弹幕位置和弹幕之间间距
使之更清晰也不影响内容

设计弹幕ICON

在保持和点赞风格同时，增加一定细节作出区分

趣味玩法加持



银临：这首歌主题是“求不得”

2:30 罗小黑：本喵空降

IP歌手和彩蛋区分设计，增加趣味玩法

引导动画设计

新用户引导 结合歌手IP引导用户发送弹幕

多场景复用

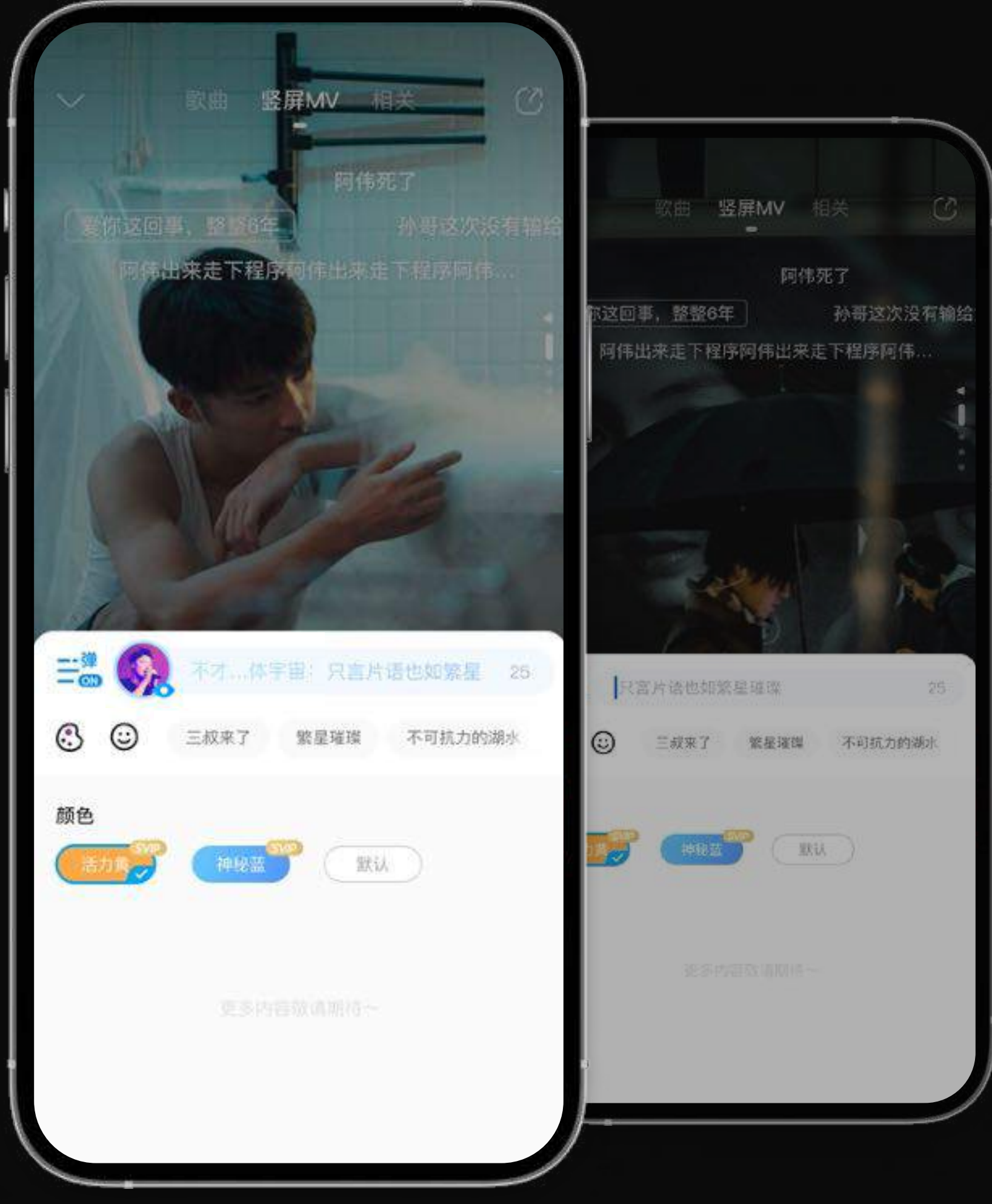

不才...体宇宙：只言片语也如繁星

只言片语也如繁星

歌手/普通输入框 区分设计



沿用竖屏弹幕样式通用到中视频

- 横屏的沉静感,使用深色配色
- 调整模块间距,为视频模块提供的增量



验证

关键设计策略

结果

01 利用IP玩法，提高可玩性，激励用户



日均弹幕数 7.8W-11.7W条 日均点赞次数增加 8.4W次

竖屏MV弹幕日均发布人数: 3.4W到4.8W人

02 多维度优化，提升用户体验



打开弹幕的用户日均 245.6W人，弹幕入口点击率 3.3%

03 有效利用引导，增加点击率

负一屏

目的目标-内容要素-落地实现-结果回收

需求拆解

目的/目标

内容要素

内容模块拆解

设计1+

交互/视觉

结果回收



需求拆解



在满满当当的整屏视频区 在功能拓展区或歌曲信息 或头部 挤进去一个图标或播放窗口显然都不太合适。

目的/目标

· 加入视频入口、增加播放时长

负一屏

安全区域

竖屏MV内容区域

· 根据这个功能和每个竖屏mv内容都有关联 又是新弹出的页面
· 想到电商里面常用淘宝二楼
(一千零一夜)

模块拆解

沉浸式的“一千零一夜” 高化非必要模块



沉浸式场景

01 头部区域 - 结合场景弱化

02 内容展示区域 - 中长视频

03 底部 信息和功能展示区 - 结合场景弱化

设计 1+

产品层-场景化设计

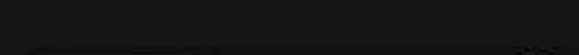
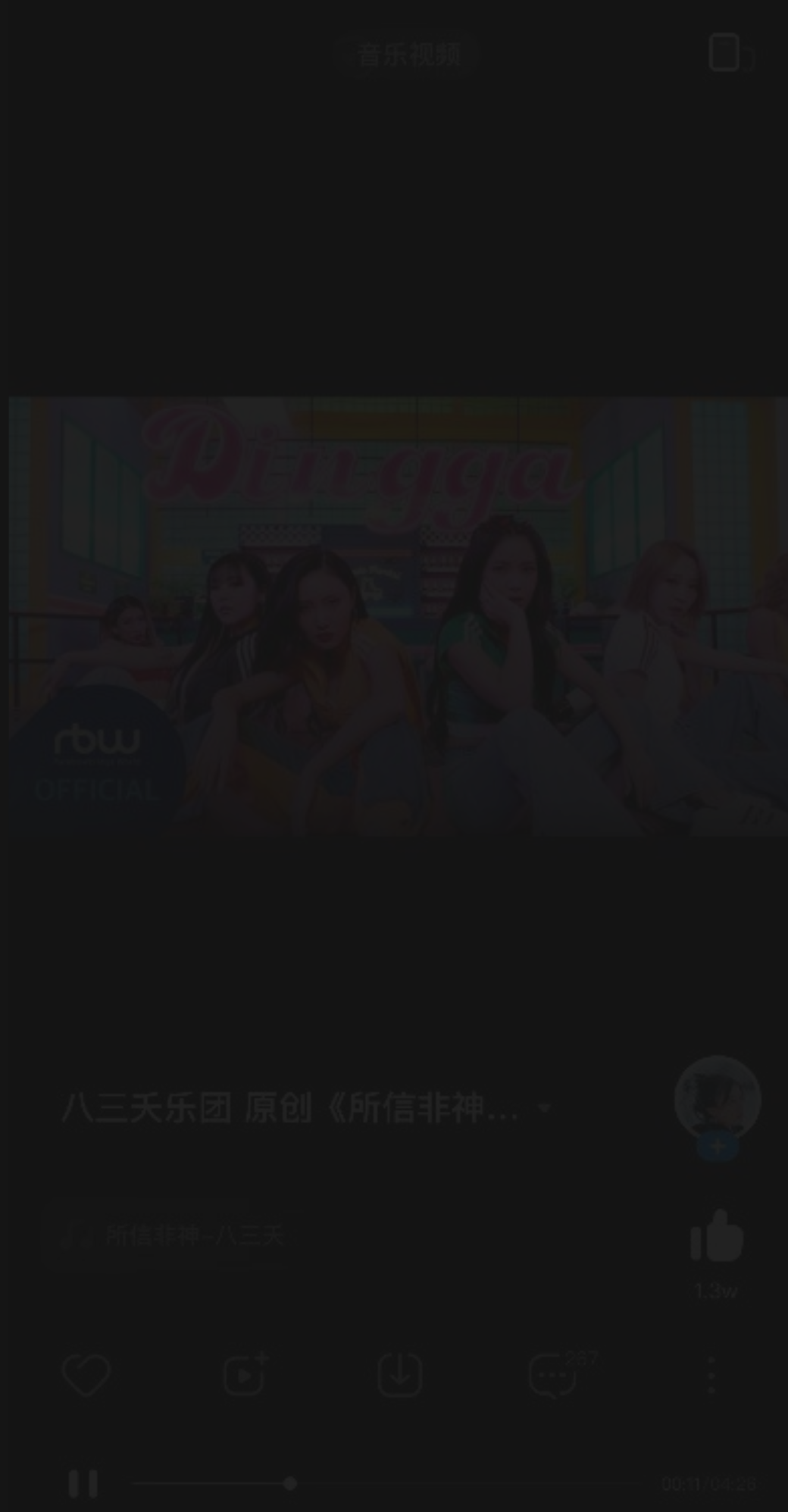

01 场景弱化，保留模块标题



02 中长视频强调内容-设定视频展示位置提升体验

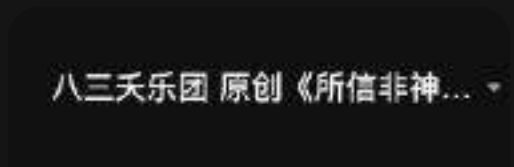

03 结合中长视频场景-弱化音乐比重-露出视频标题模块

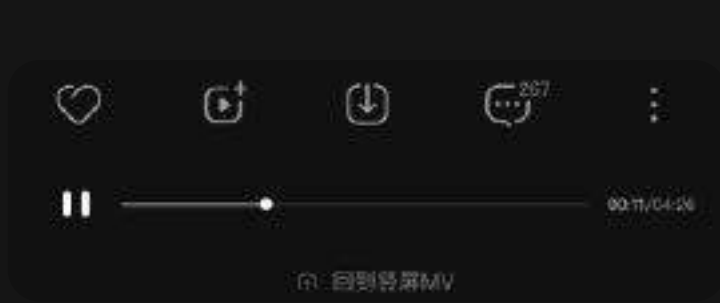

04 弱化播放，进度条功能，增加沉浸感

分模块拆解设计

交互层· 体验1+支持

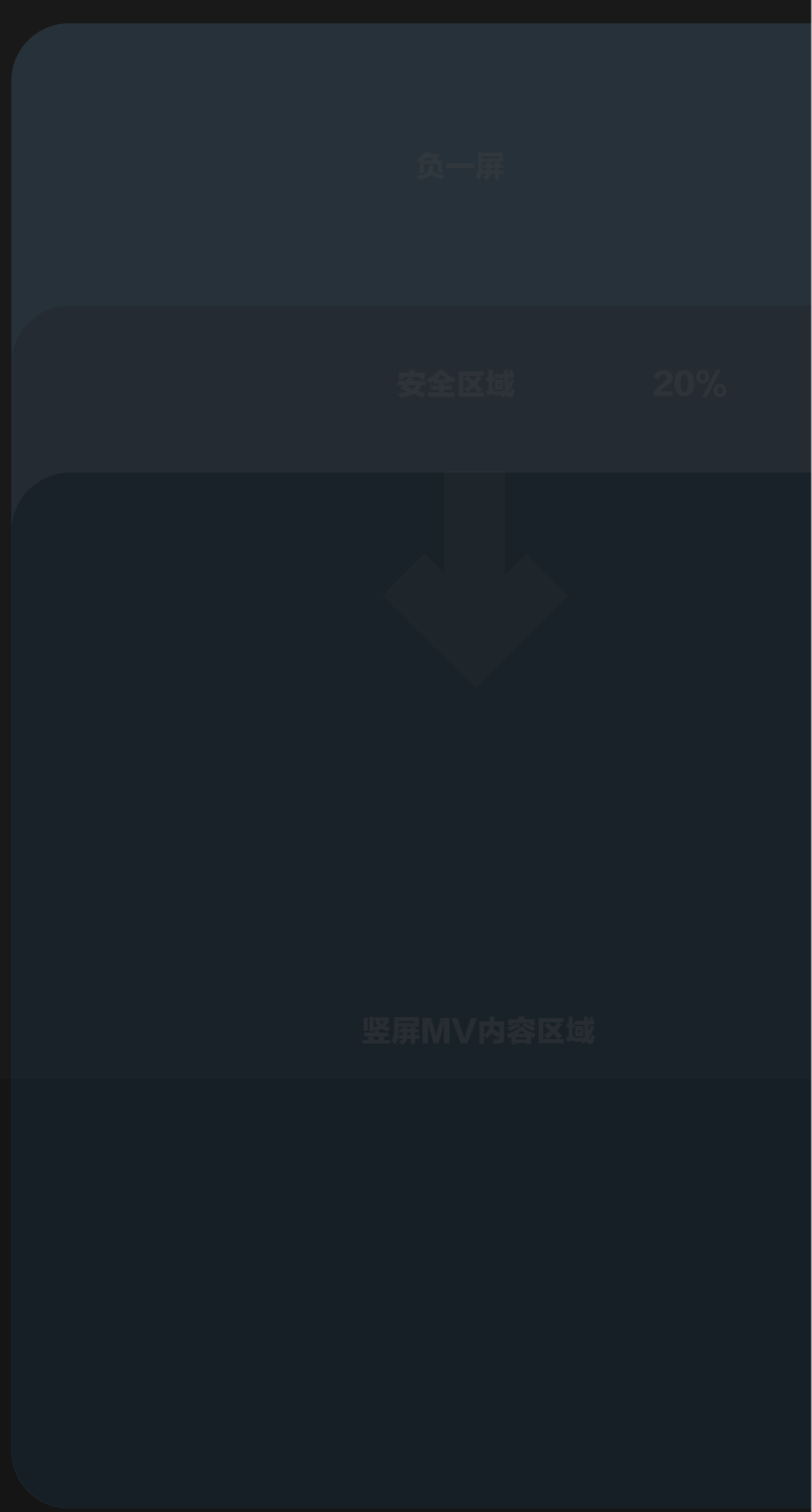

交互切换细节设计

设计切换demon，规范安全区，提升用户切换体验

抓住黄金时刻

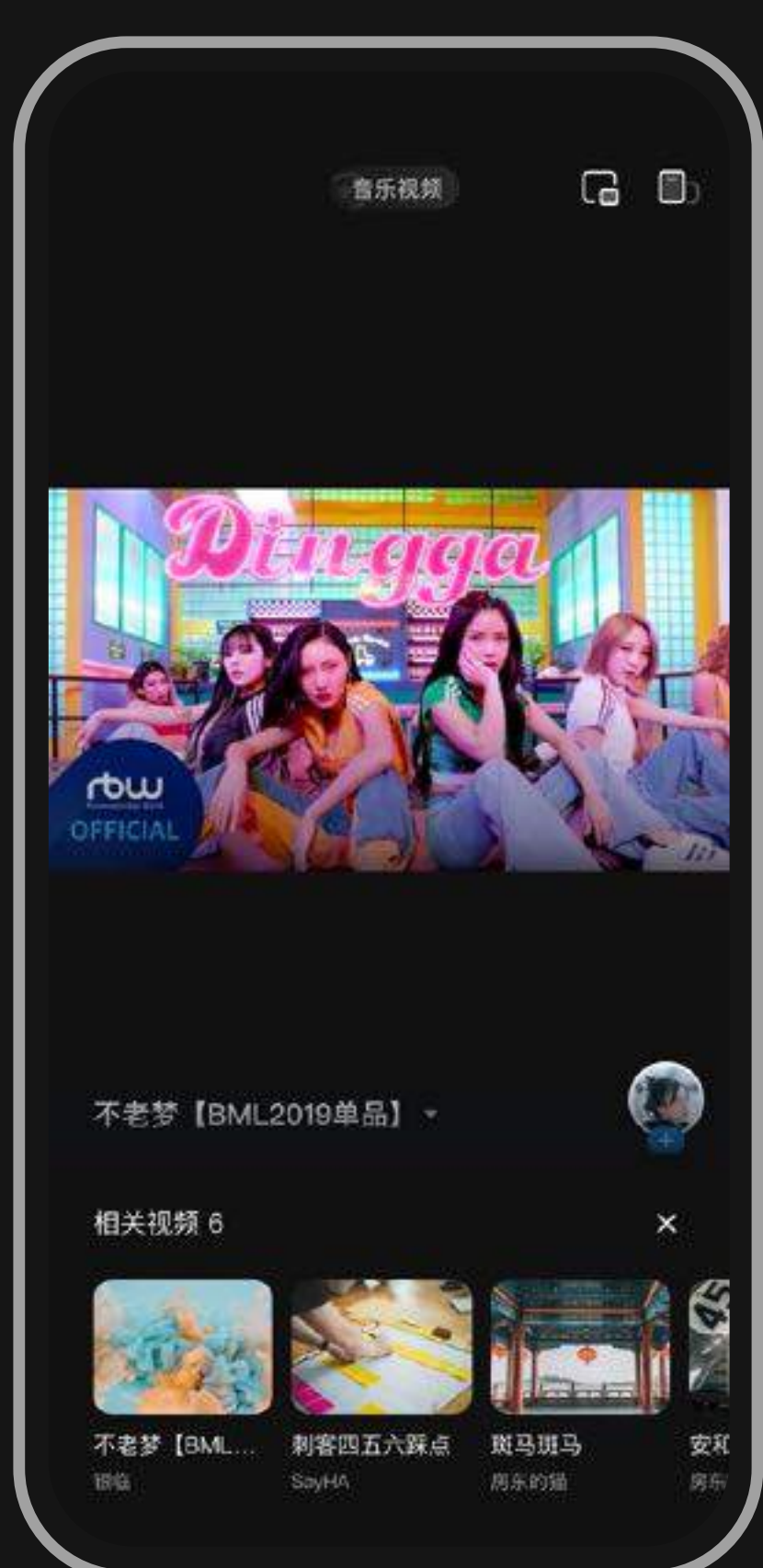

03 抓住黄金时刻，设计无痕沉浸式弹窗样式，推荐更加顺滑

相关视频 6



结果回收

人均播放时长 **+46s**

设计1+策略

01 模块拆解结合场景设计

02 动效赋能交互，优化体验

03 黄金时间，结合场景抓住用户

玩法尝试

互动

全景

播单合集

长音屏



K 酷狗音乐 | 视频

视频改版优化 - 沉浸式AB 视频双列AB

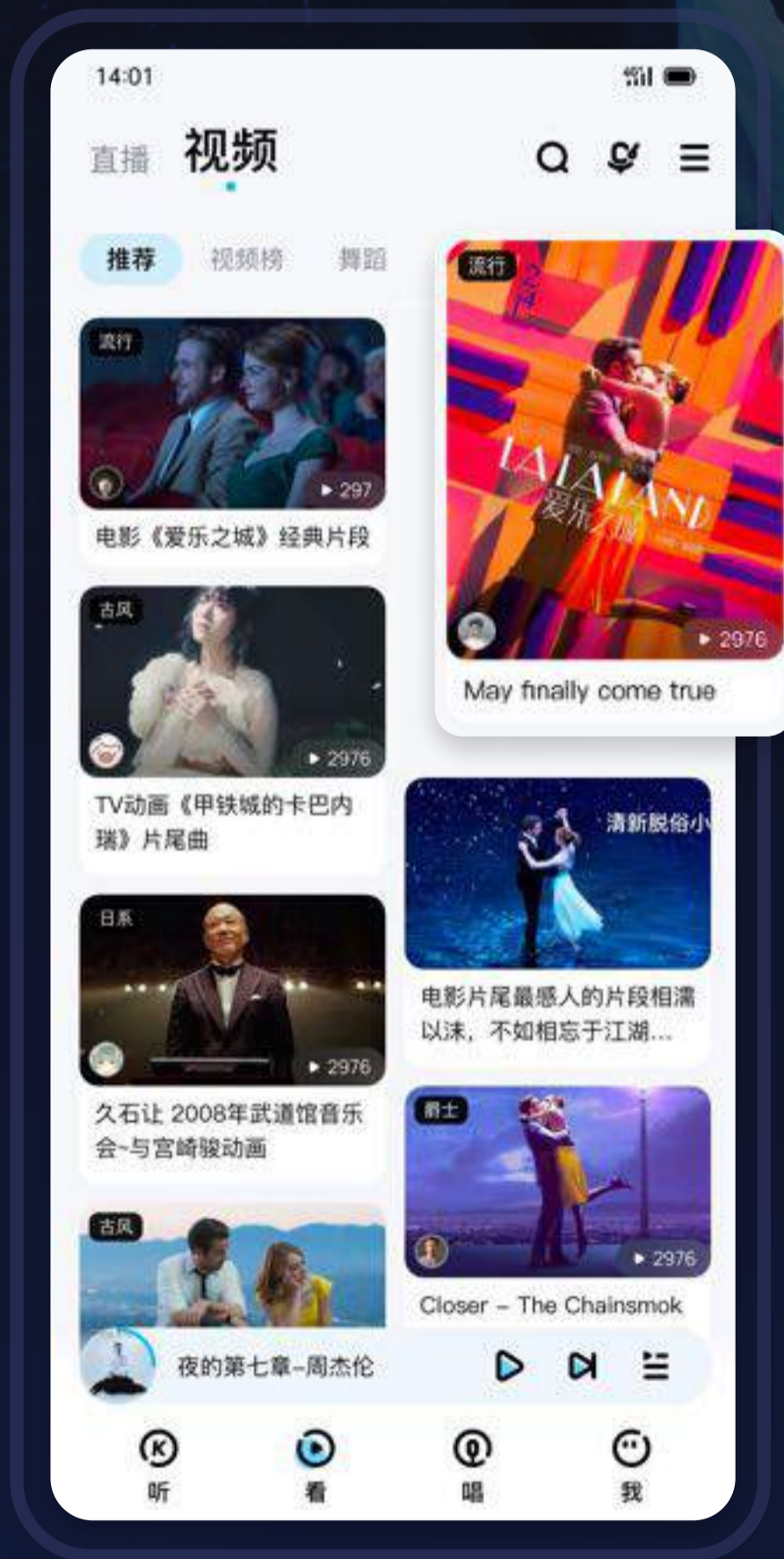
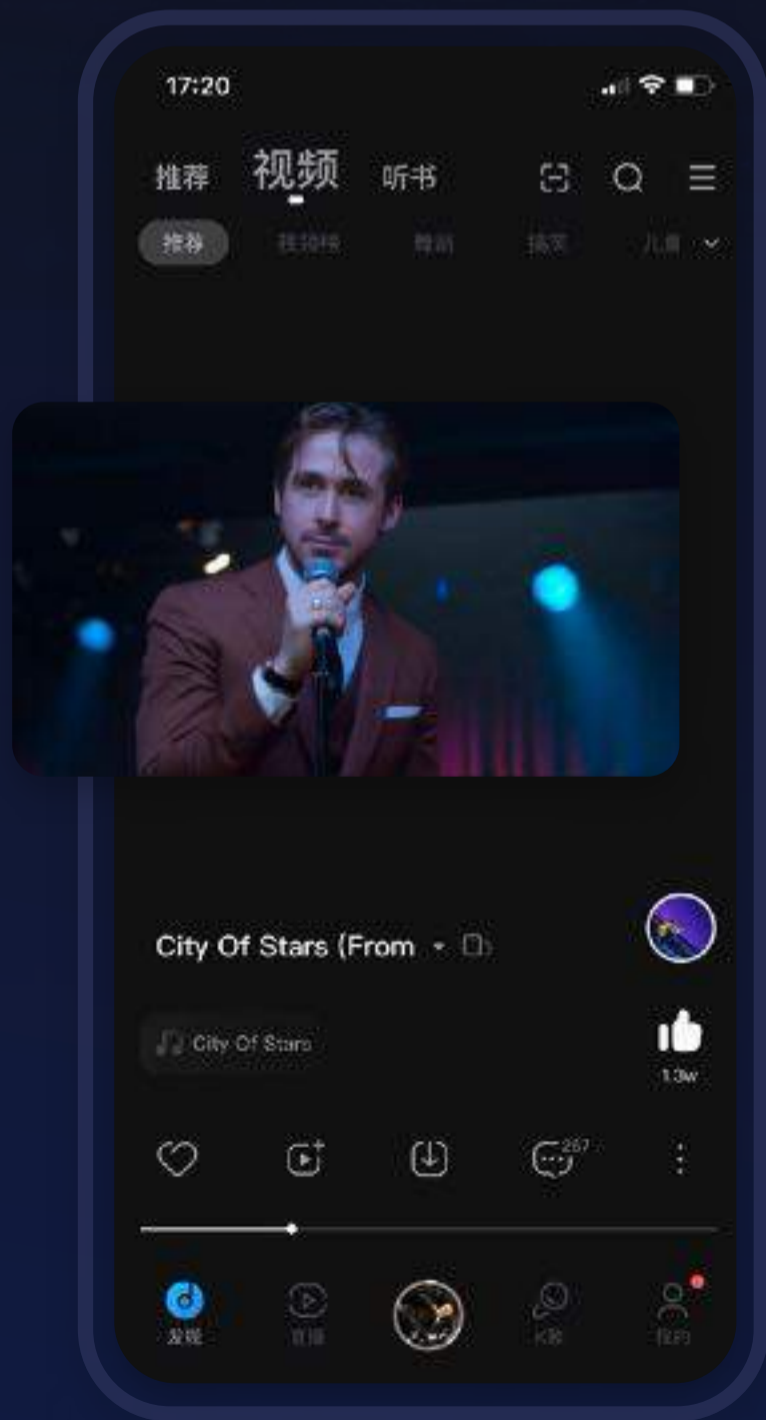

设计策略



设计目的: 优化沉浸体验
产品目标: 提高用户点击量, 播放时长

问题解析

卡片过大	视频大卡片排版排列, 点位太多, 不利于用户浏览
设计样式不统一	视频无人性化, 设计样式和排版整体样式不统一
信息不明确	单个卡片信息不明确, 用户无法快速获取信息点
玩法单一	内容不够优质, 在单一维度排列下, 玩法单一

AB方案策略

AB方案确认—设计单链对多面反馈—数据回收

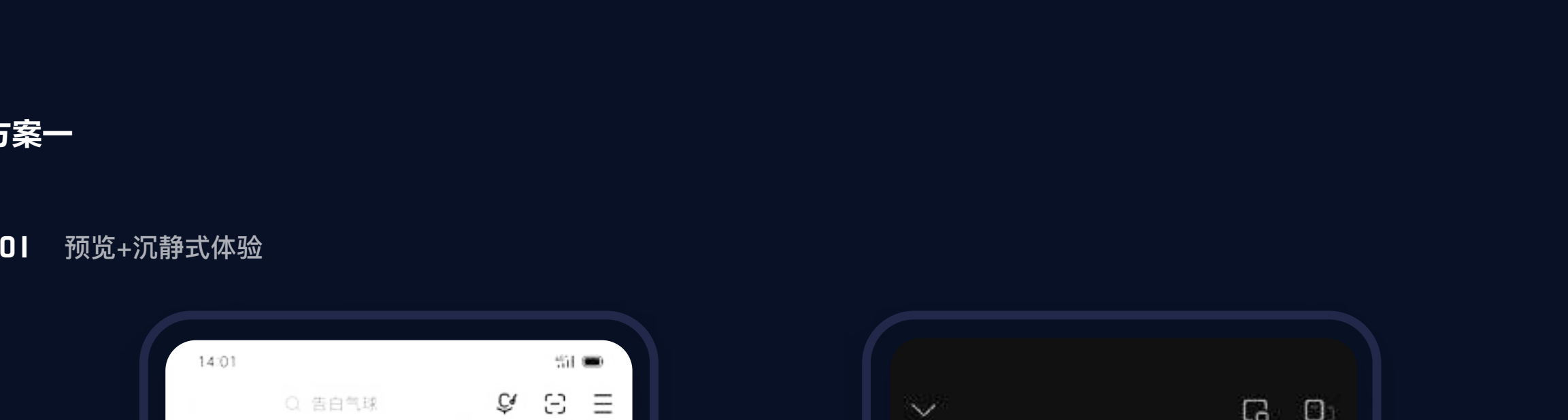

方案一

01 预览+沉浸式体验

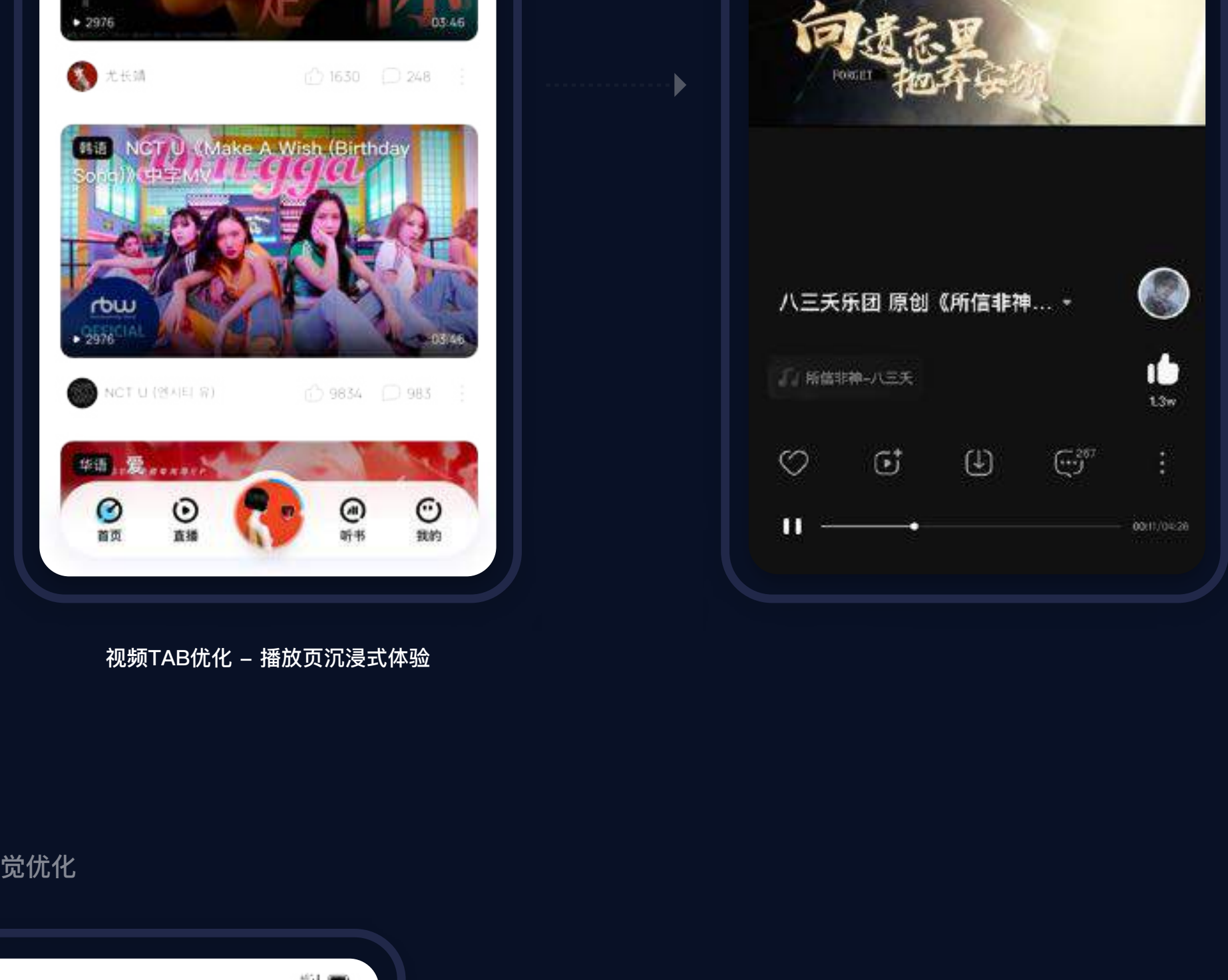

视频TAB优化—播放页沉浸式体验

外卡片视觉优化

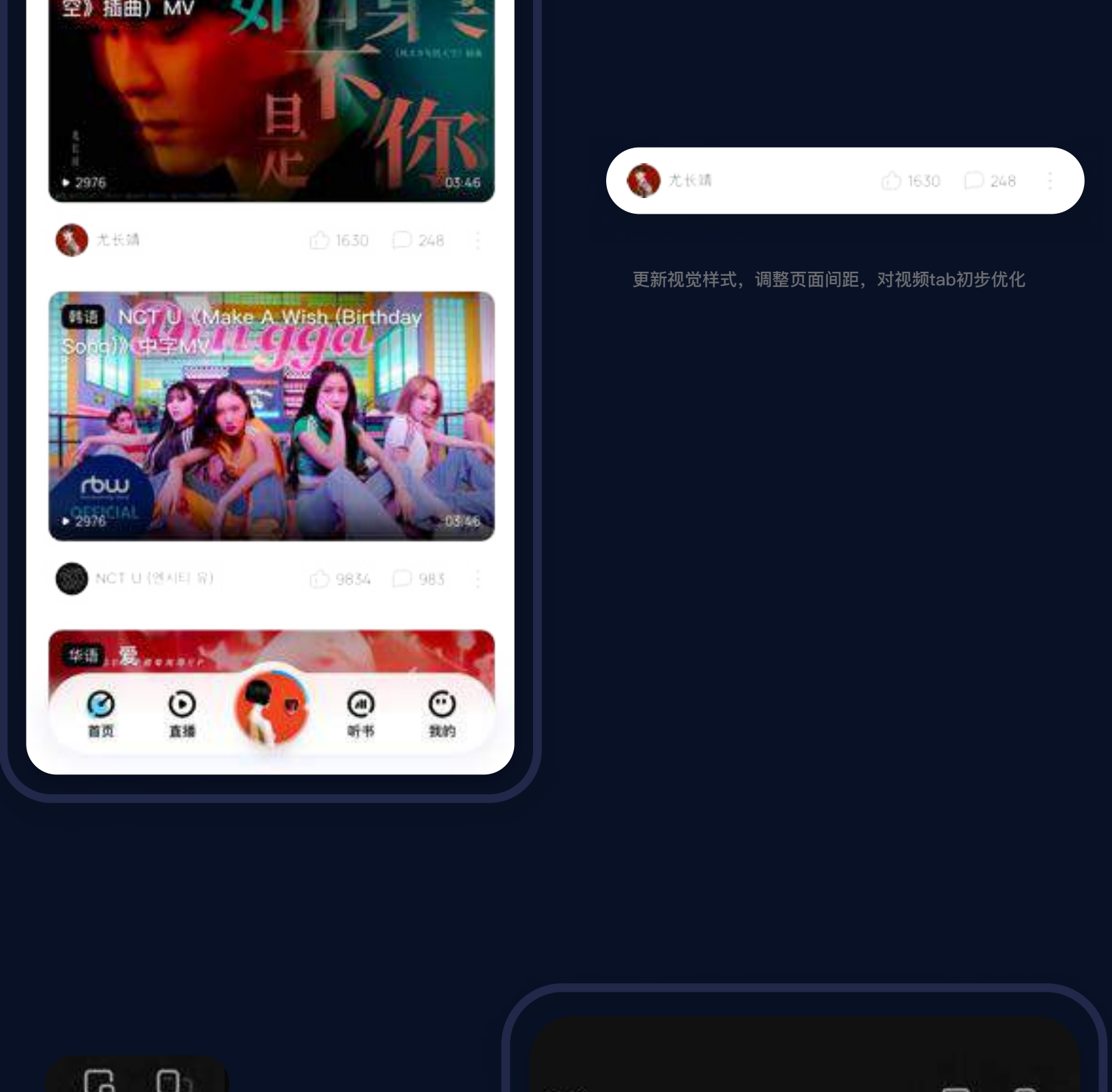

01 场景弱化, 增加沉浸感



02 中长视频强调内容

设定视频展示位置提升体验

03 结合中长视频场景-弱化音乐比重

露出视频标题模块



04 弱化播放, 进度条功能, 增加沉浸感

复用 负一屏沉浸式样式

方案二

02 入连式沉浸体验



视频TAB全页沉浸式

01 结合场景—适配沉浸式tab



02 设计新的控件交互方案



03 兼容性设计, 适配竖屏场景

沉浸式设计



小结

- 1.AB整体风格保持一致, 针对沉浸式弱化控件
 - 2.结合场景, 优化控件和交互
 - 3.对通用模块优化, 排除它因干扰
- 观察AB方案的数据好坏确定优先级

通用模块优化

通用模块优化

优化横屏投票界面 新增弹幕功能



根据以上各个功能数据表现对功能筛选, 重点设计图标调整界面

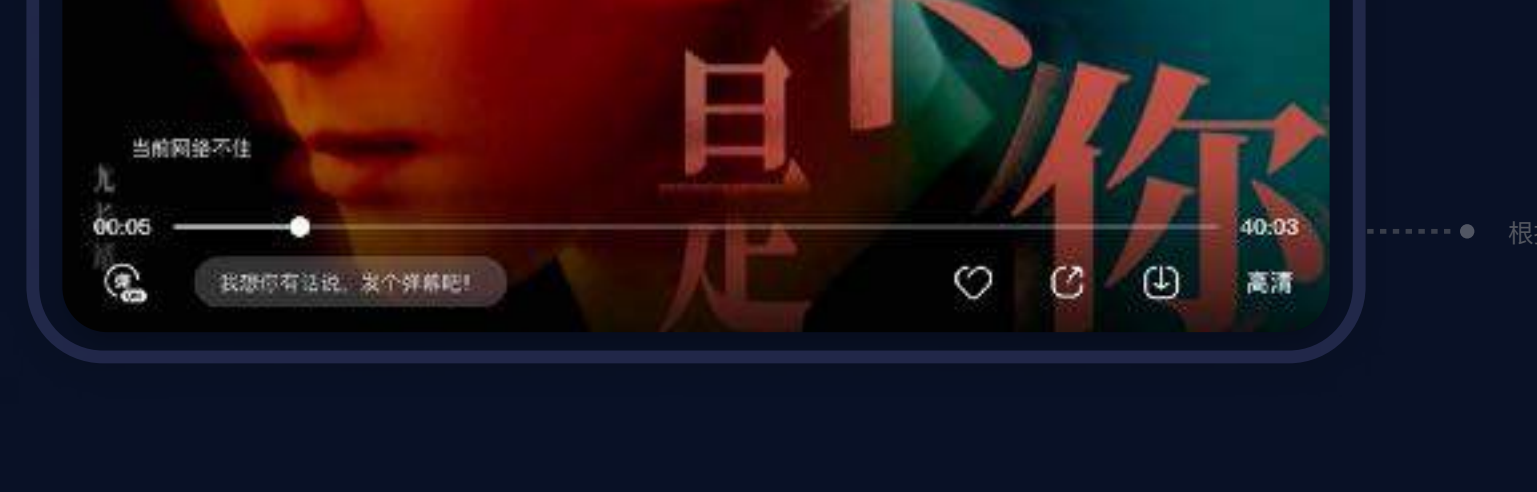

弹出式弹幕横屏界面设计



沿用竖屏MV弹幕设计适配沉浸式场景

优化投票流程和功能界面

结果验证设计

A方案	B方案	小结与复盘
人均播放次数 较线上版本 高约9次	人均播放次数 较线上版本 高约5-20次	两个方案数据从播放次数和播放时长都有明显的提升 A方案播放时长会稍优于B方案, 播放次数B方案浮动较大 数据可能受到TAB直接沉浸式的影响, 综合A方案更加合理 而之B方案中的播放次数波动, 可在TAB双列方案中验证
人均播放时长 较线上版本 高约2分钟	人均播放时长 较线上版本 高约1-2分钟	

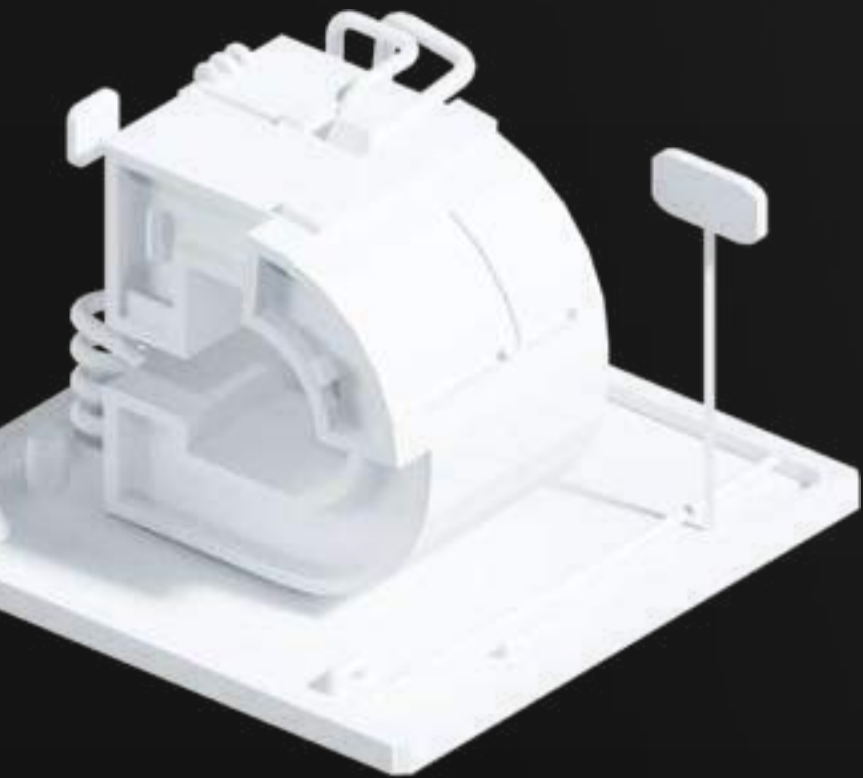

DASHBOARD

0-1/1+

0-1重优化视觉改版+交互微调

产品定位-用户群体

PRODUCT POSITIONING

产品定位

Sass工具

纯Sass模式

主 Web 端

跨境支付

跨境支付Sass工具，为跨境电商和外贸B2B商户提供数据跨境收付兑服务

用户群体

 Fordeal

 PatPat

 The ROYAL MARSDEN
NHS Foundation Trust

 International
House
Bangkok

 shopify

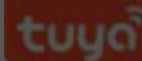
 tuya

 International
House
Gateway

问题分析/确认改版范围

PROBLEM ANALYSIS

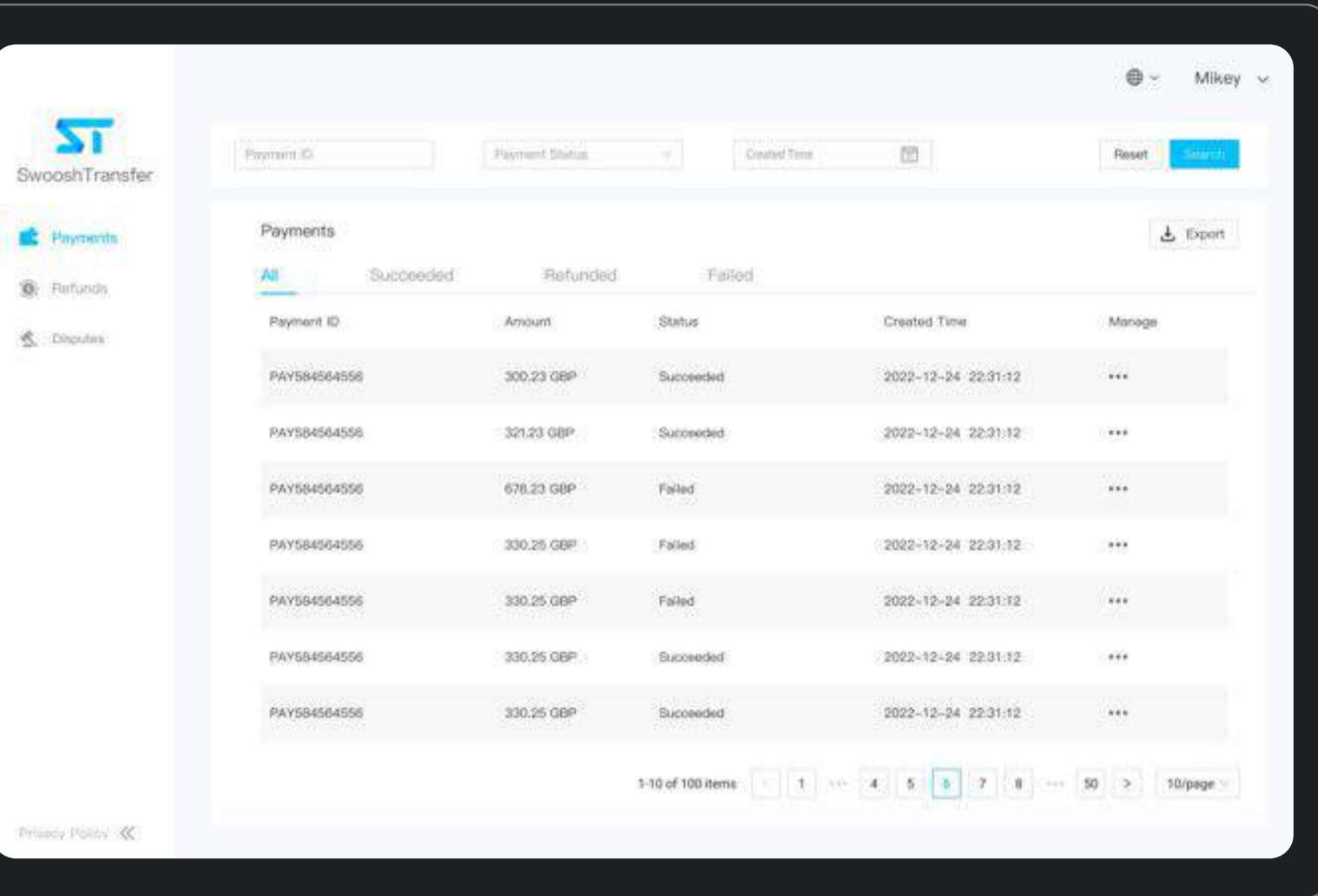

问题

版块信息不突出
视觉元素老旧，无品牌感
原有交互逻辑奇怪
线上和设计相差甚远

目标

整体视觉改版优化
简洁/清晰/品牌感...
交互功能针对优化调整
基础版式+基础交互逻辑

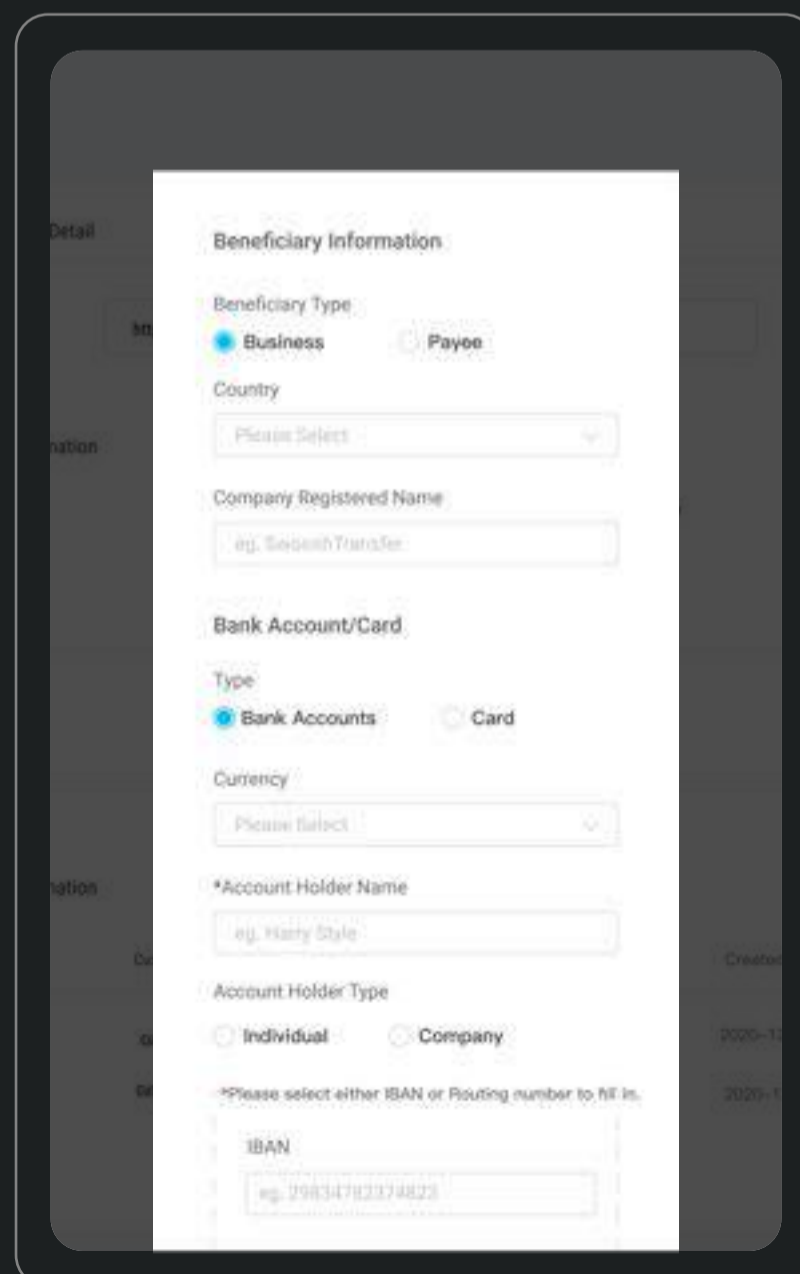
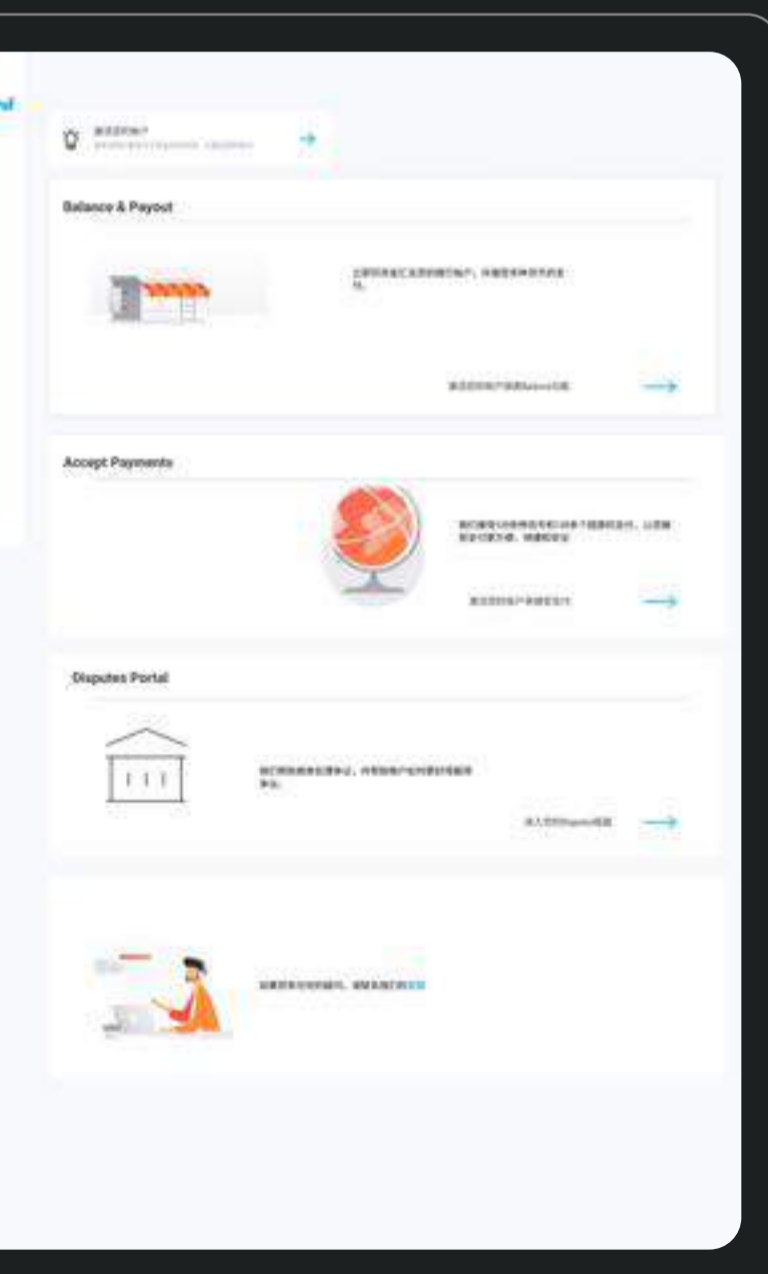

风格定位/设计原则

STYLE ORIENTATION



简洁/清晰

明确的层级和版式



品牌感/LOGO

视觉元素的渗透



数据/品质感

明确的层级和版式



风格传承

风格和相关元素传承
样式清晰明确

视觉突破 3D建模+AI

STYLE ORIENTATION

利用3D建模+AI，产出突出品牌的强视觉类图

3D



AI

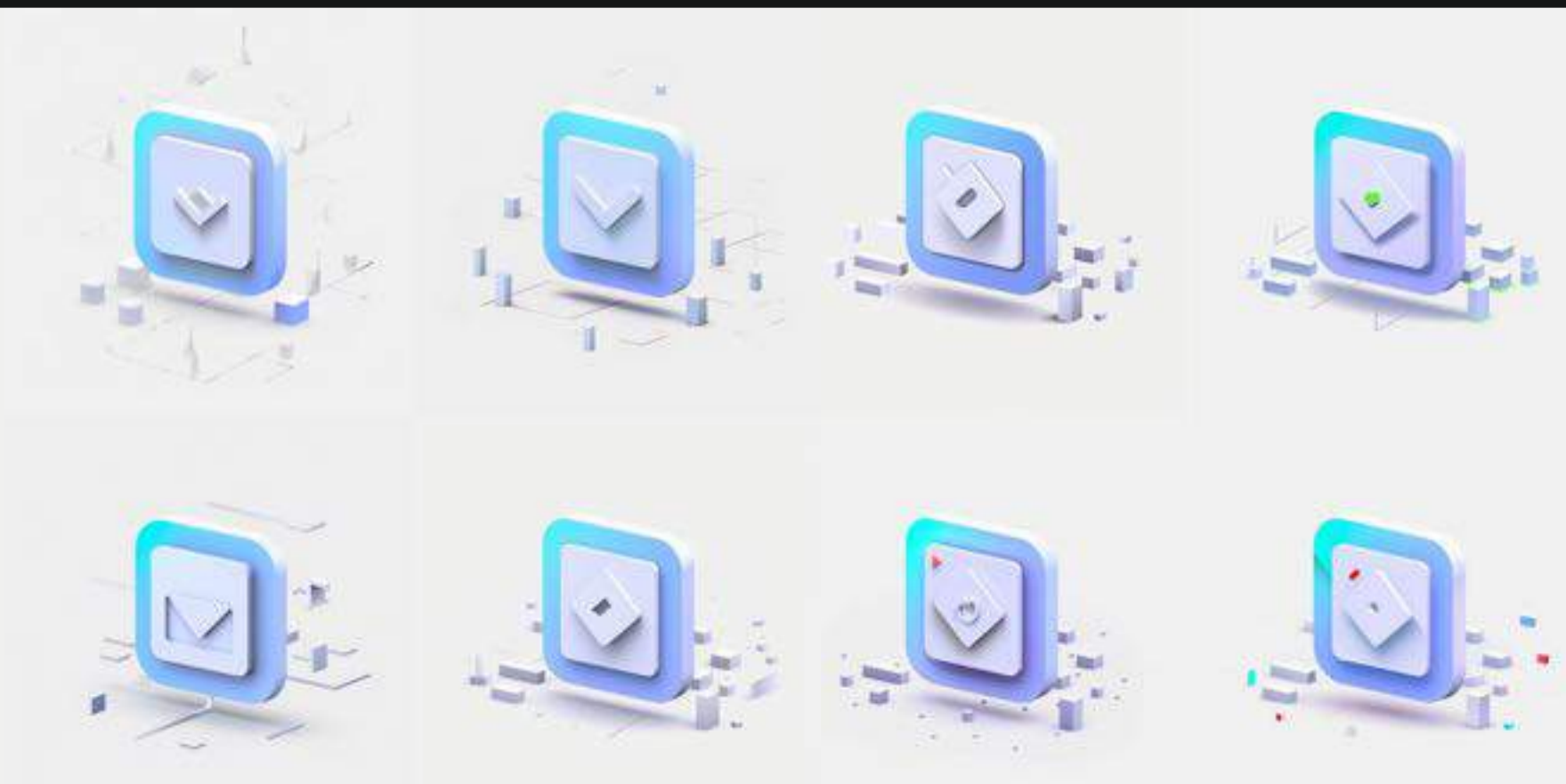

改版优化+交互细节调整

STYLE ORIENTATION

原子元素优化

颜色



#009DD1



#00BFFF

对颜色进行微调，使其更加活泼，更符合跨境的气质

icon+Logo

Dashboard

LOGO 重设计

Dashboard

黑+蓝 - 缺角设计 = 沉稳不缺活泼

非斜体+ 非衬线 = 专业/简洁

icon重设计

 Overview

 Balance

 Payments

 Disputes

 Payout

 Developer

 Overview

 Balance

 Payments

 Disputes

 Payout

 Developer

 Payment Link

设定点击状态

重设计ICON 使其更贴近含义，并沿用LOGO视觉元素，保持统一

改版优化+交互细节调整

STYLE ORIENTATION

模块优化

版式

调整基础版式样式

顶部栏

展示LOGO 和 非重要功能

功能导航层

重要导航器
功能之间快速
切换

背景层

内容层

展示导航层具体
内容, 包含表单
列表, 信息填写

优化基础版式样式

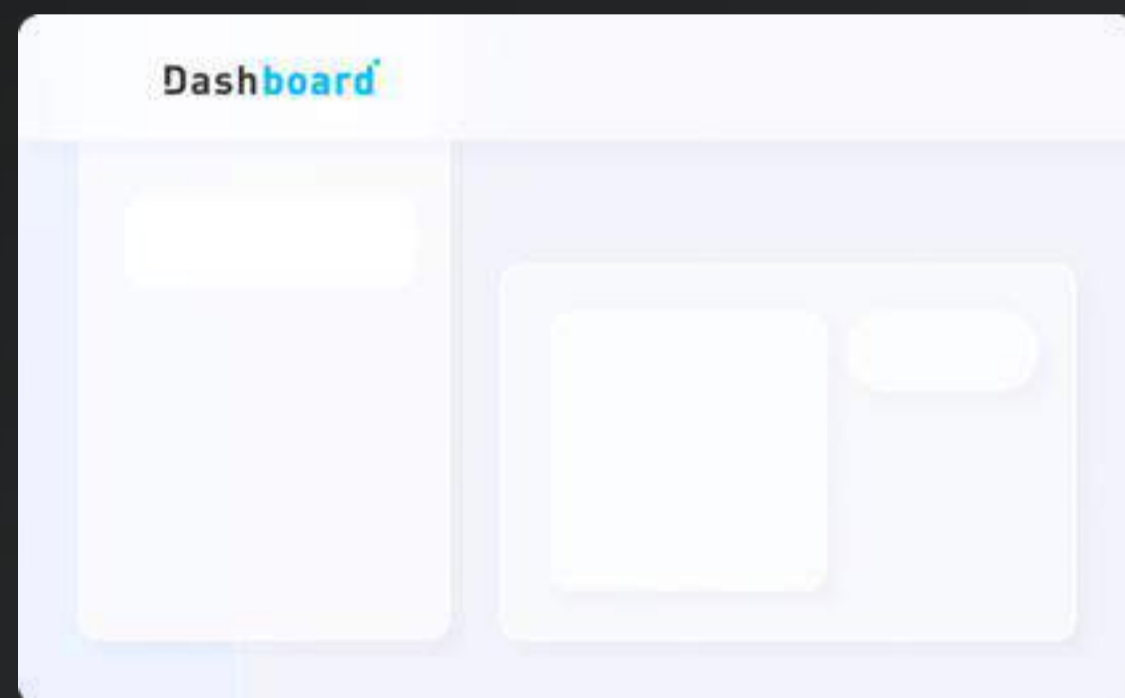

交互逻辑

重设计ICON 使其更贴近含义, 并沿用LOGO视觉元素, 保持统一

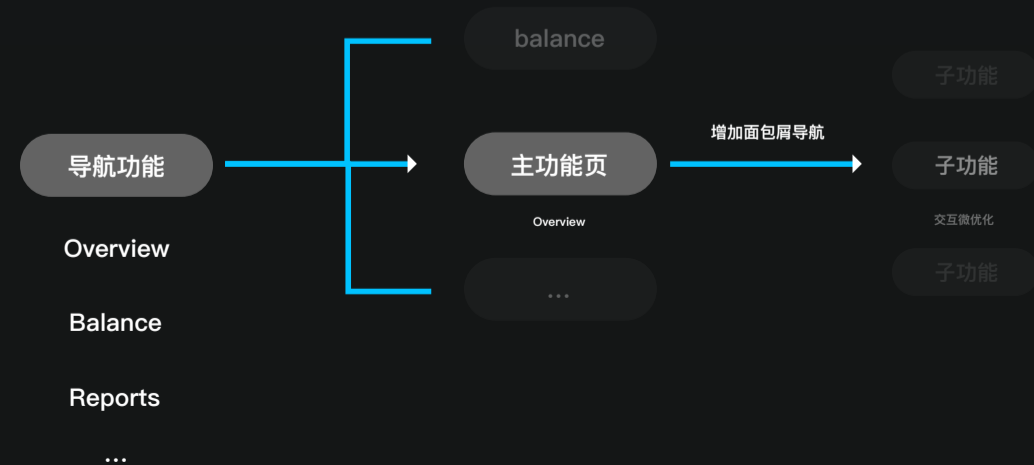

产出 新按钮样式和交互细节

large



middle

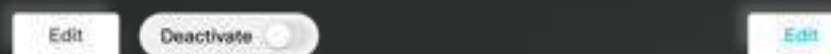

small

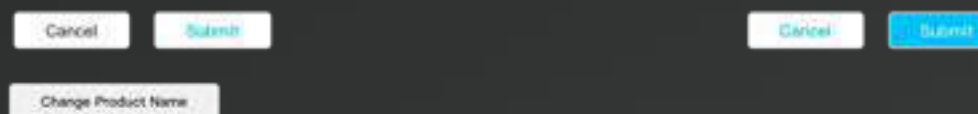

ON BOARD

登录注册+新商户的进谏

3d建模 探索品牌可能性

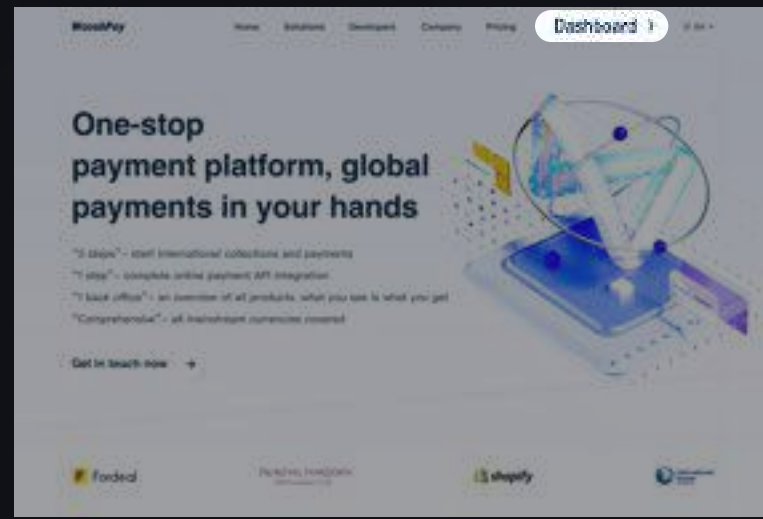

3d建模 探索品牌可能性

- 灵动 S
- 简洁 D
- 质感 W



数字城市

中心D处理中心

通过管道连接到处理中心，表达进谏的过程

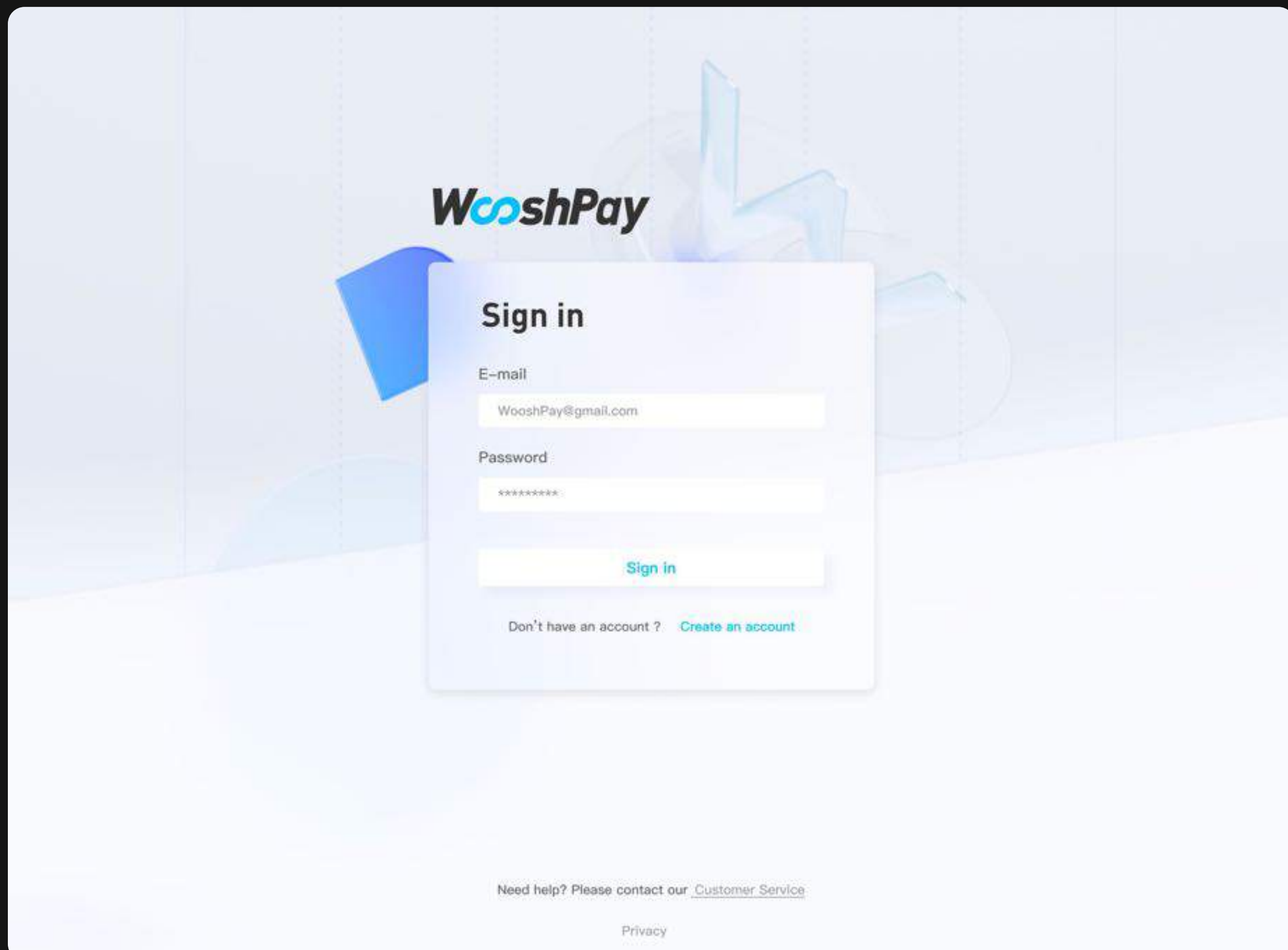
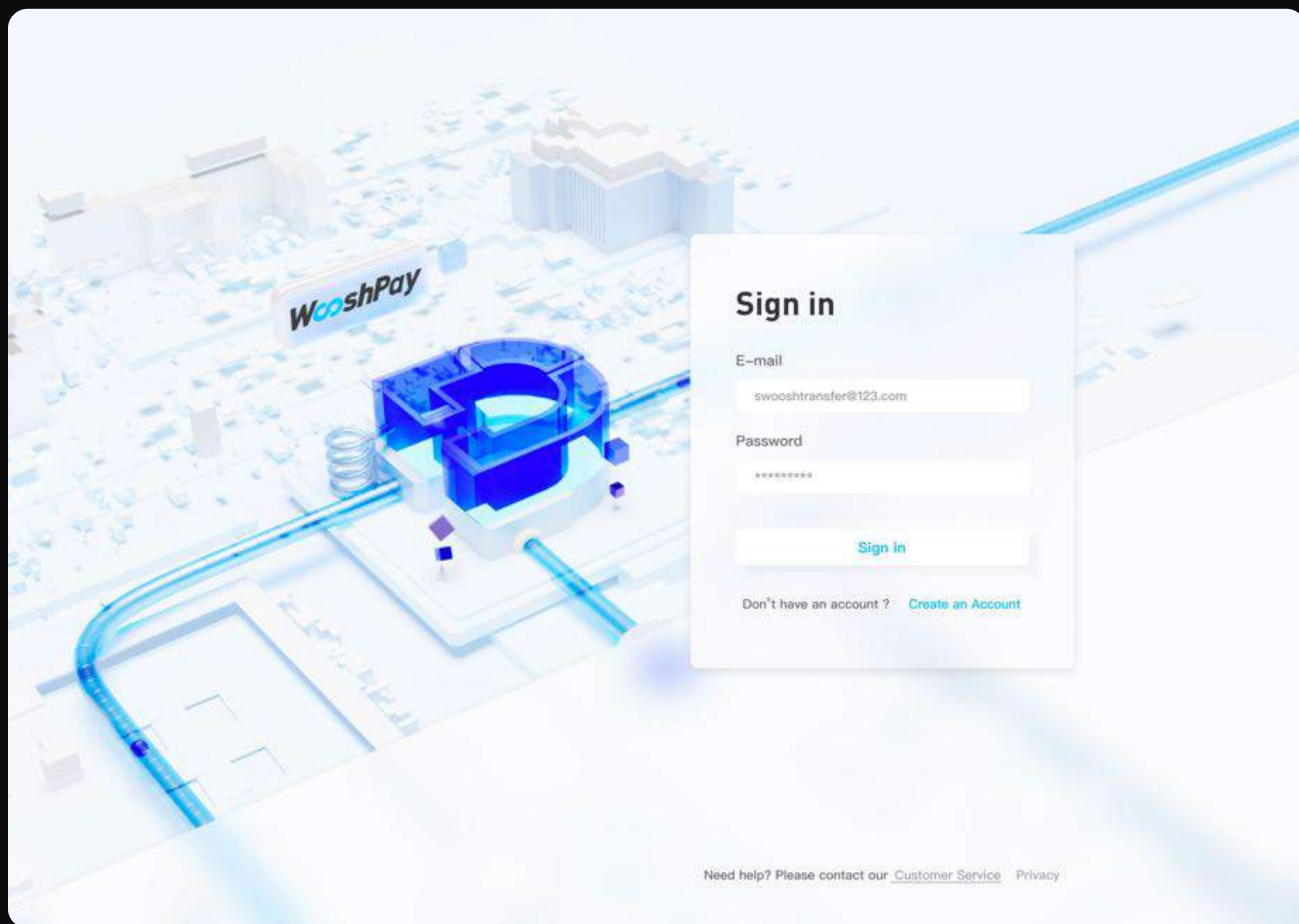

新商户进谏

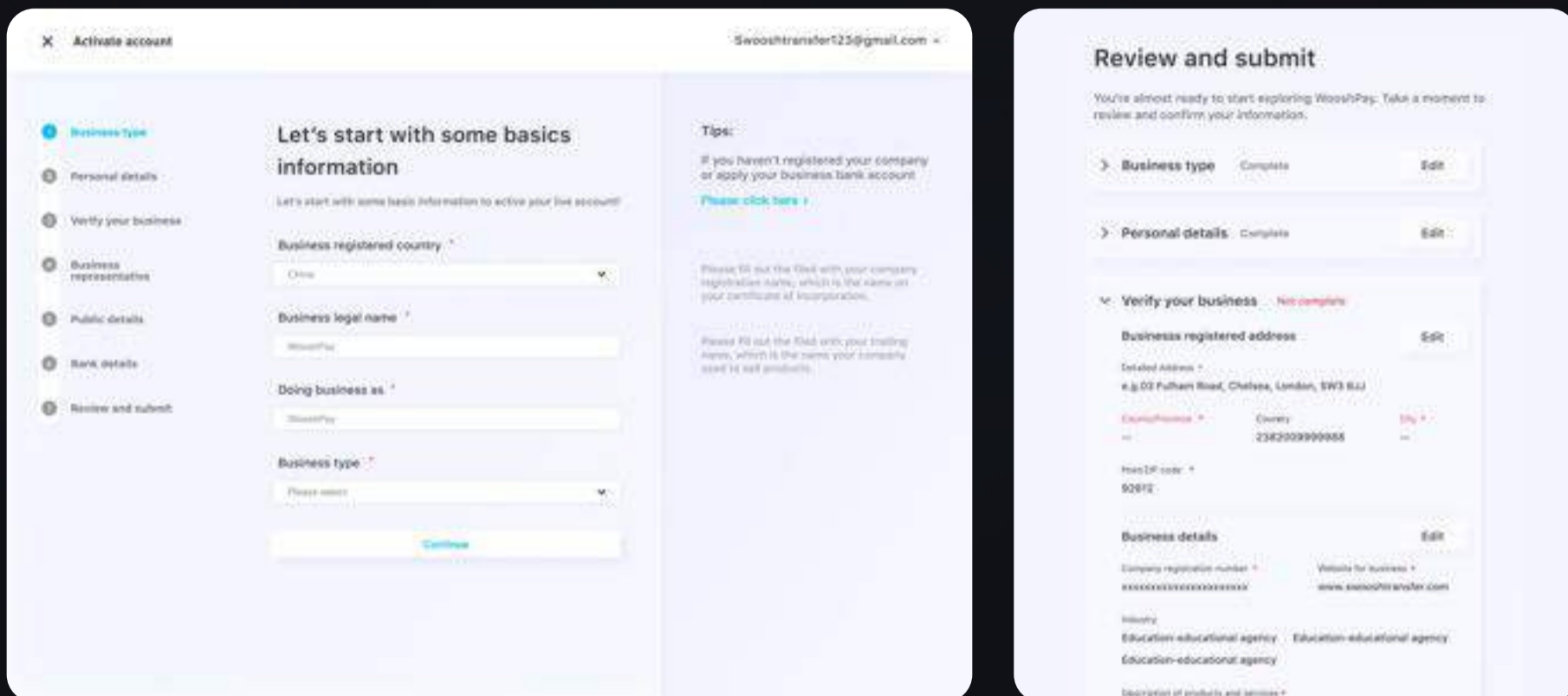

设计优化进谏流程，达到更好用户体验

- 1 Business type
- 2 Personal details
- 3 Verify your business
- 4 Business registered address
- 5 Business details
- 6 Business representative
- 7 Public details
- 8 Bank details
- 9 Review and submit

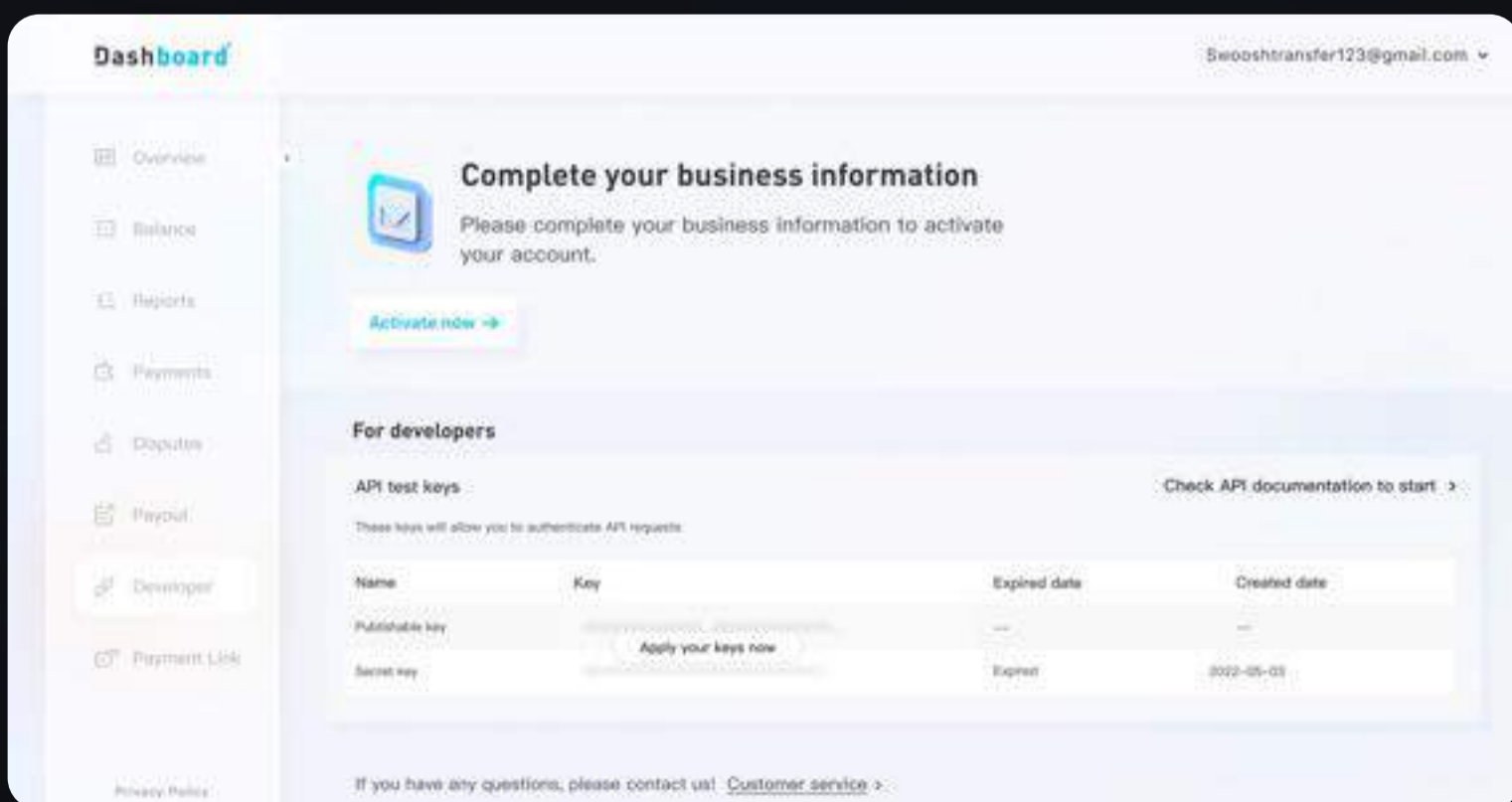

在进谏过程中实时展示商户所处状态，利用AI生成相应图片

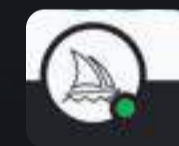

Midjourney Bot 2023/05/08 16:18
<https://s.mj.run/g8hMbpD0PvI> <https://s.mj.run/mMT3...>
icon,white background,Gross material,blender,high det
-v 5 - Image #3 @67

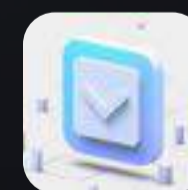

线上体验地址<http://dashboardtest.swooshtransfer.com/login>

全局优化改版

Pay out Overview Report ...

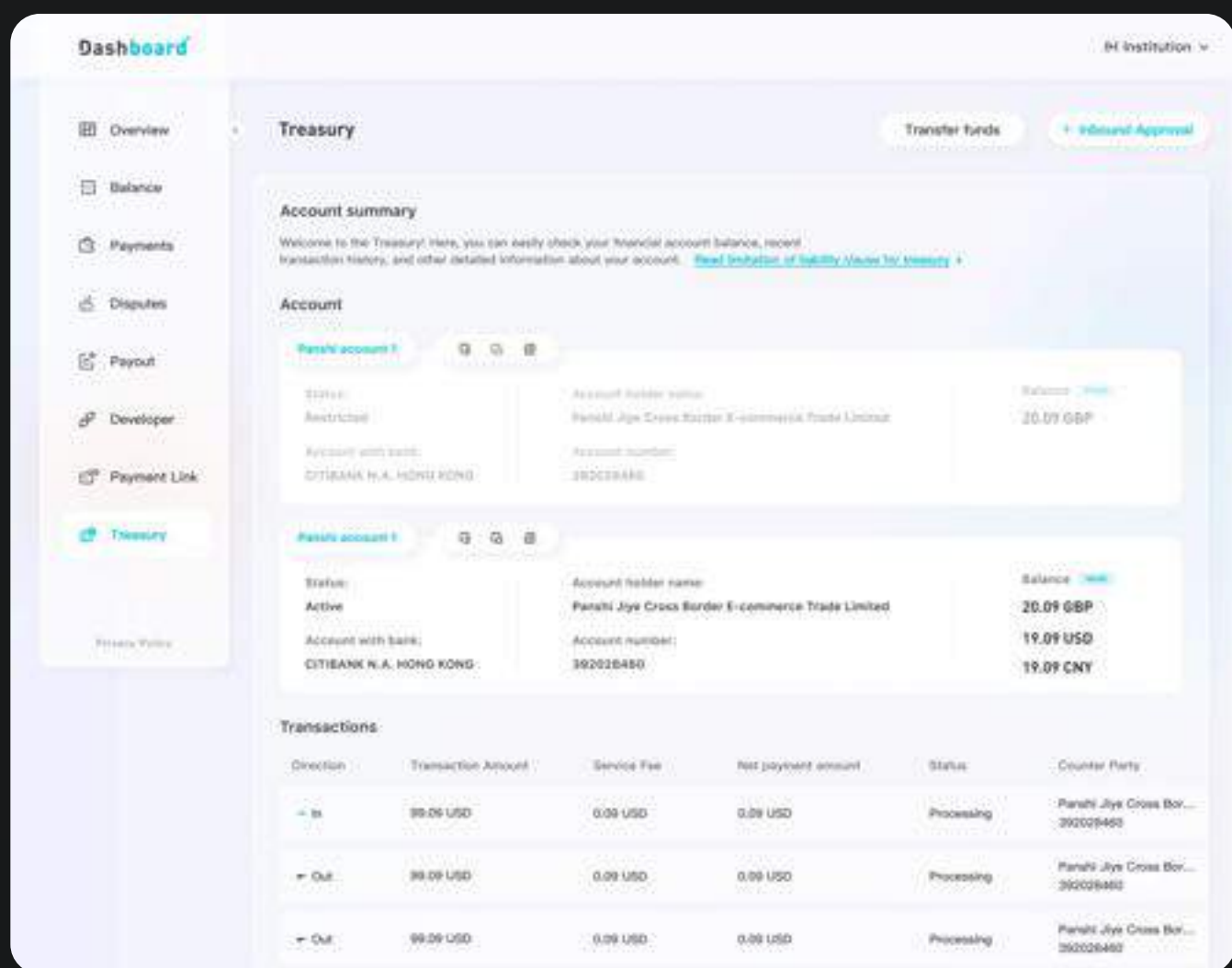
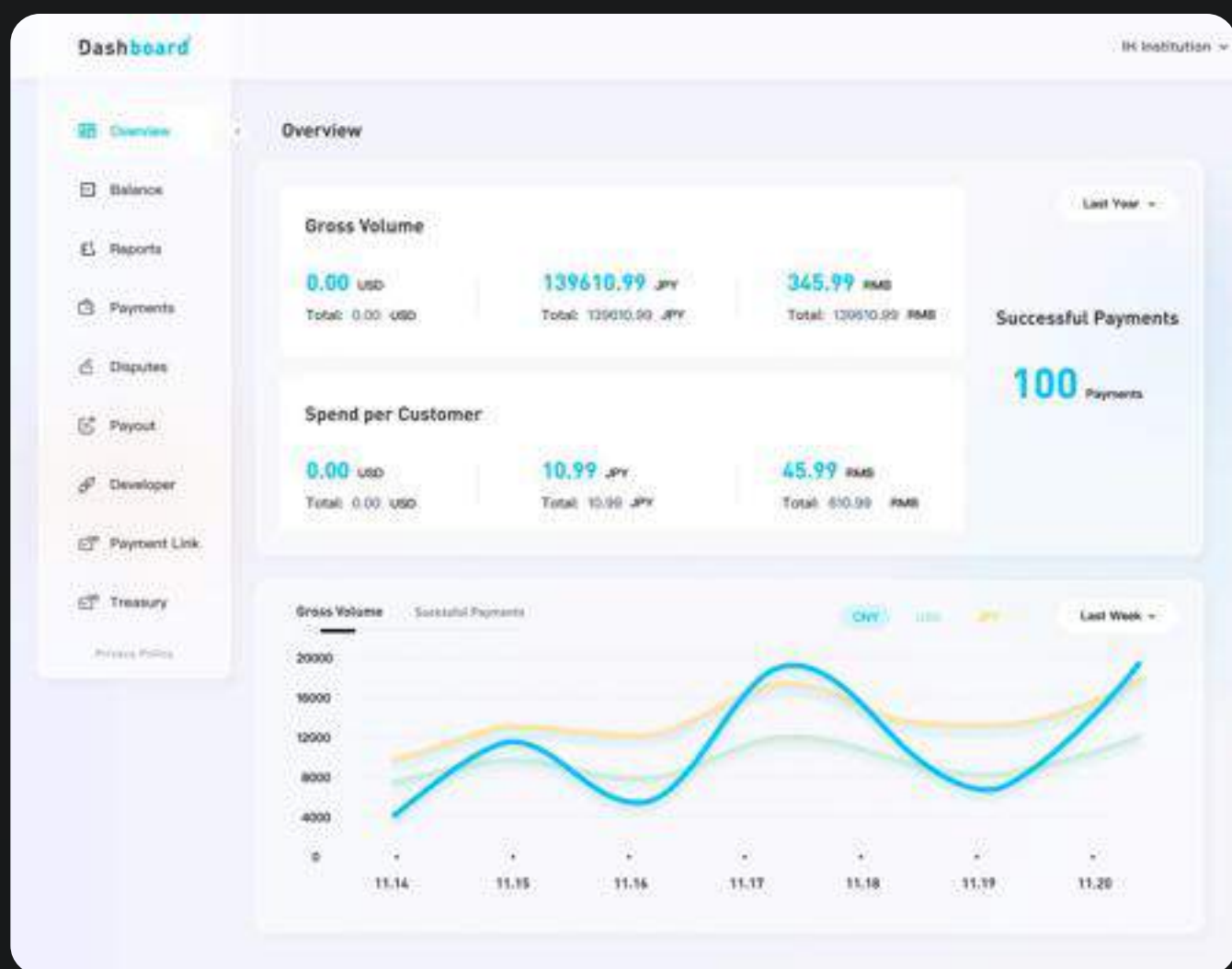
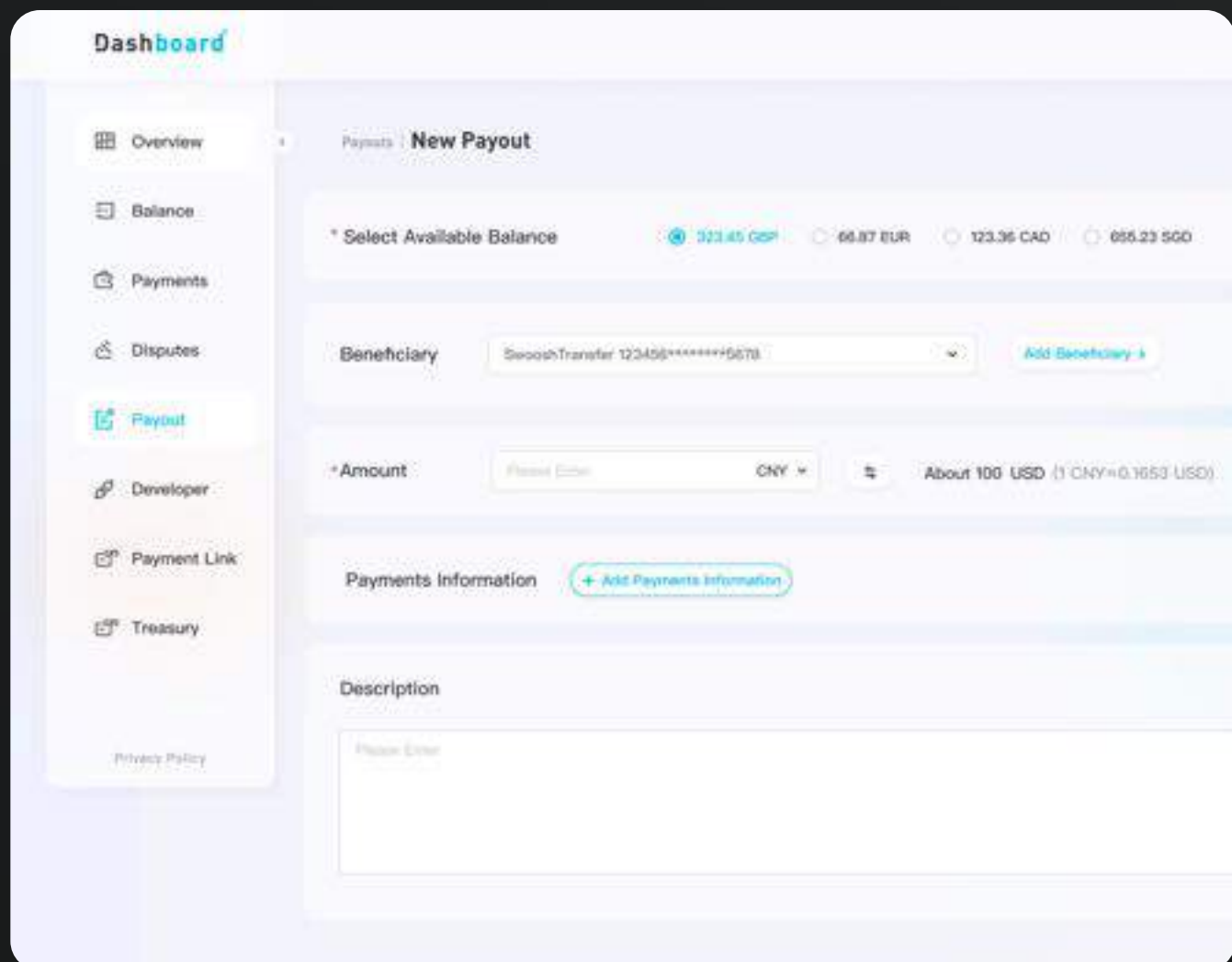
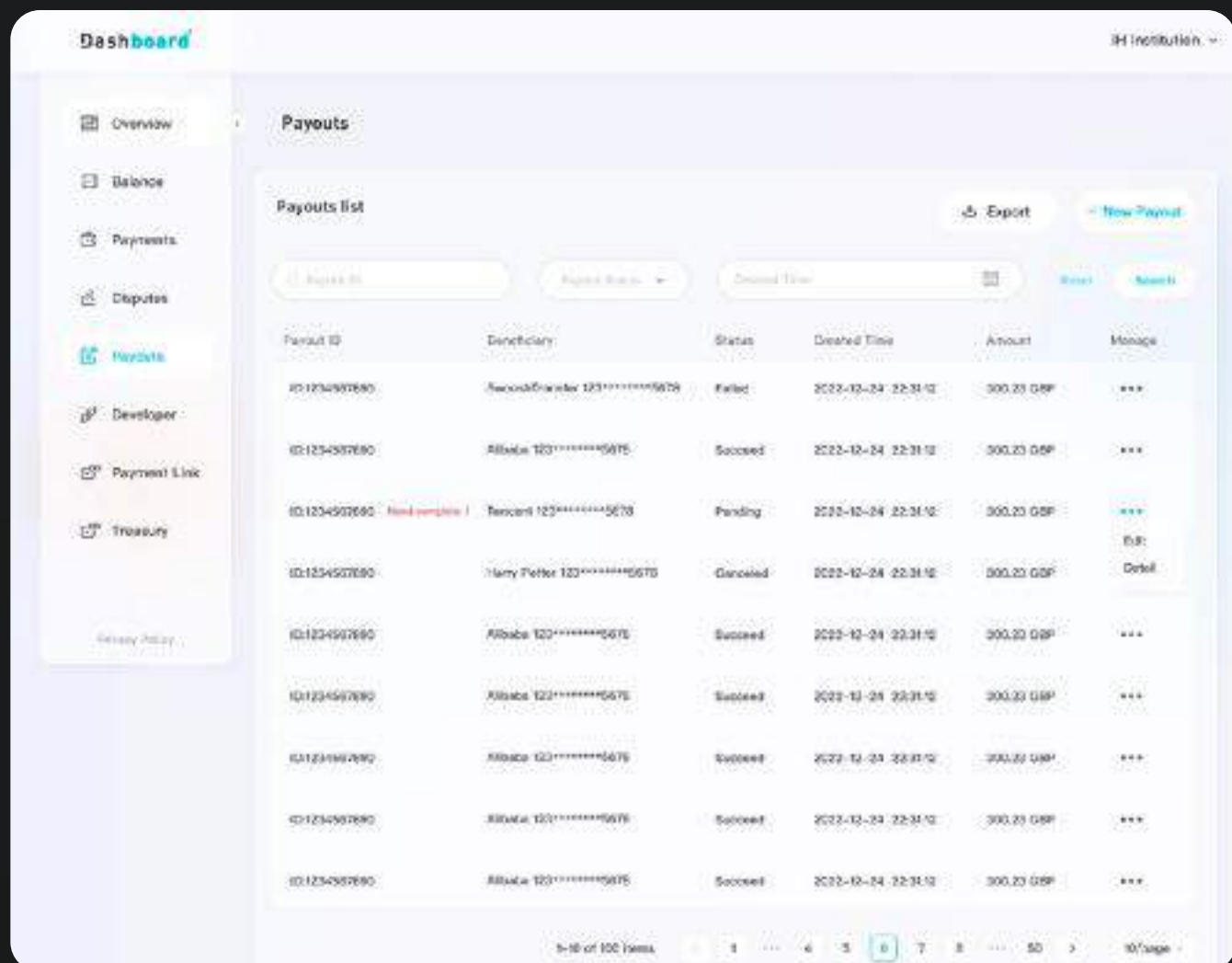

针对性优化不同功能的视觉和交互细节

体验地址: <https://www.figma.com/proto/znUQ4K1c9WU2LVGLWOGC75/Untitled?page-id=0%3A1&type=design&node-id=36-12159&viewport=-4270%2C-18218%2C0.21&scaling=min-zoom&starting-point-node-id=36%3A12159>

模块化定义

面包屑

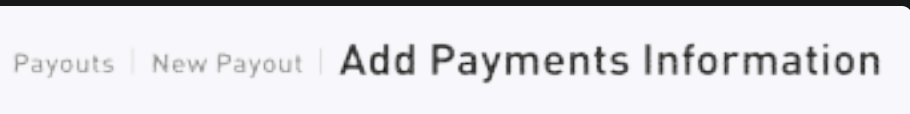

分页器

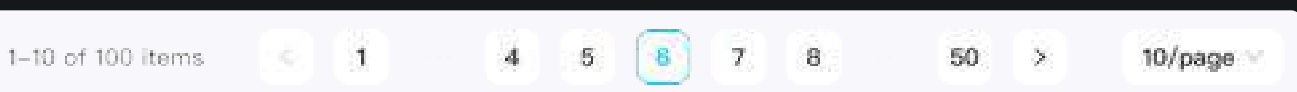

搜索栏



表单模块

信息填写模块

列表内容模块

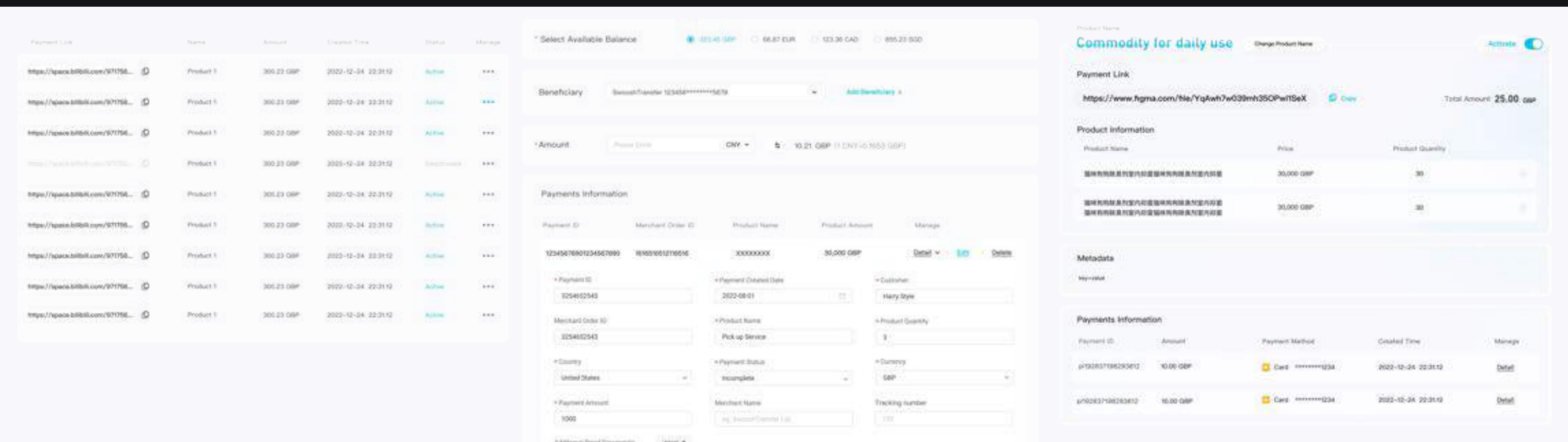

移动端适配



WcoshPay

收银台工具

官网



CHECK OUT 工具

线上体验地址<http://dashboardtest.swooshtransfer.com/login>

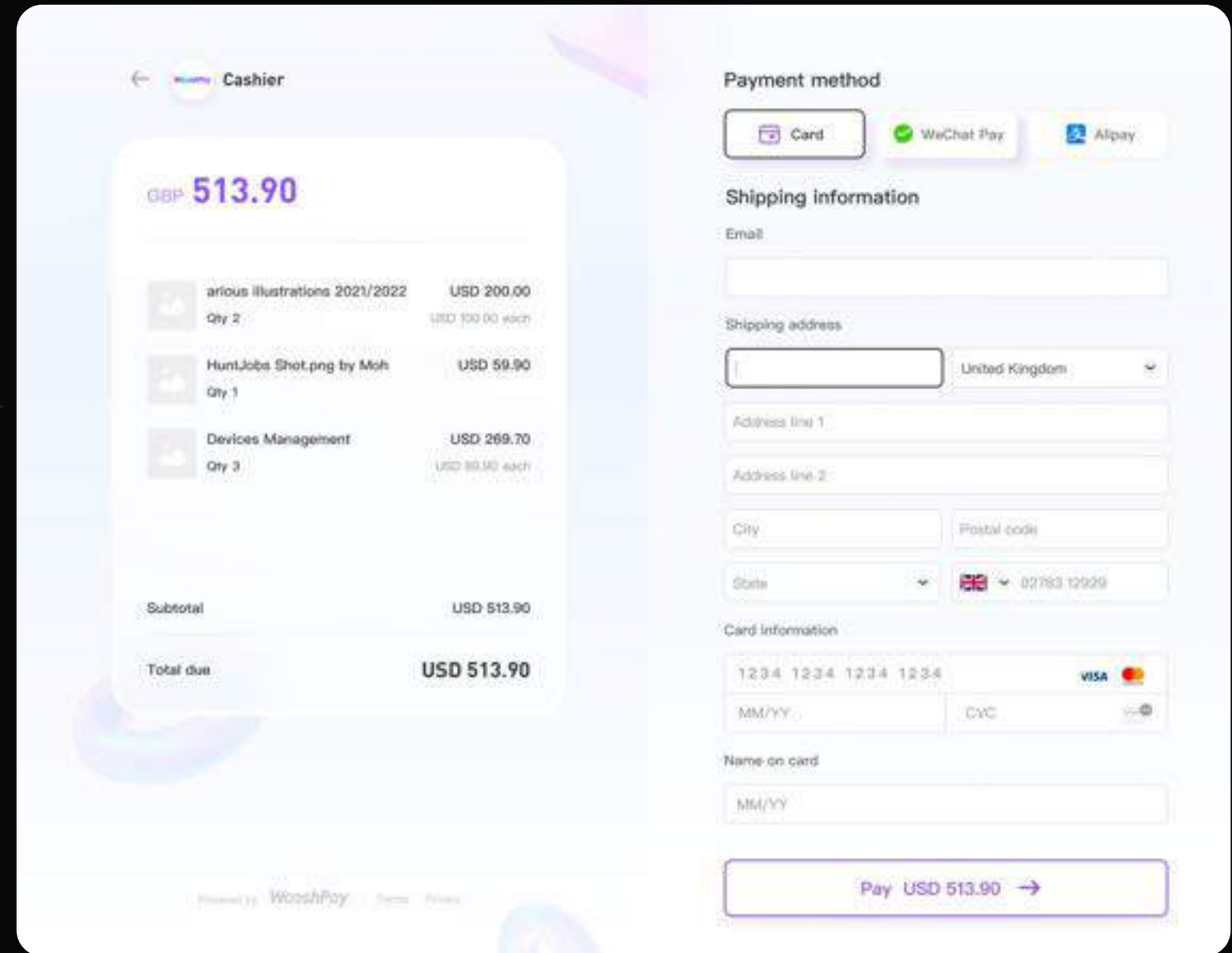
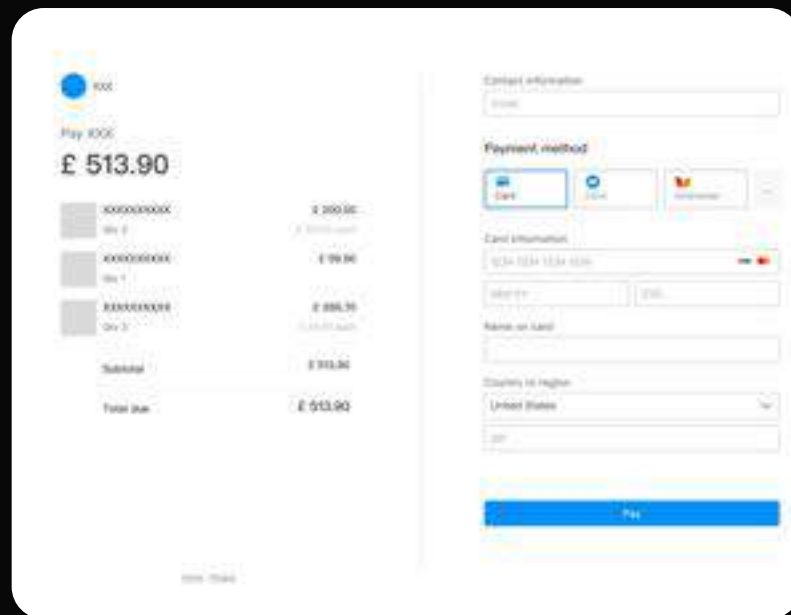



视觉元素-莫比乌斯环

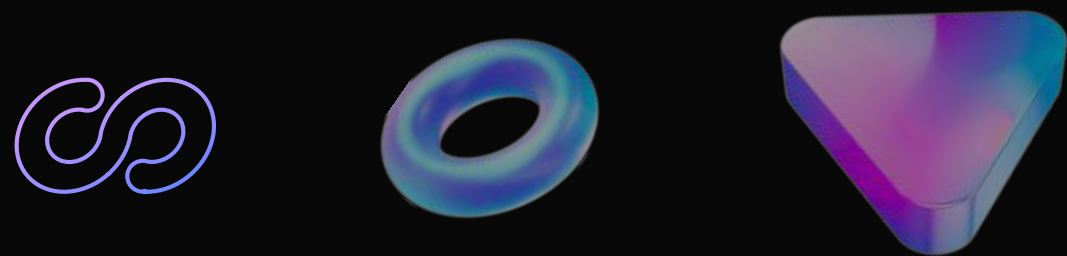

信息层

展示商户相关信息

调整版式，优化字体等视觉元素，拉开关系提升用户阅读体验

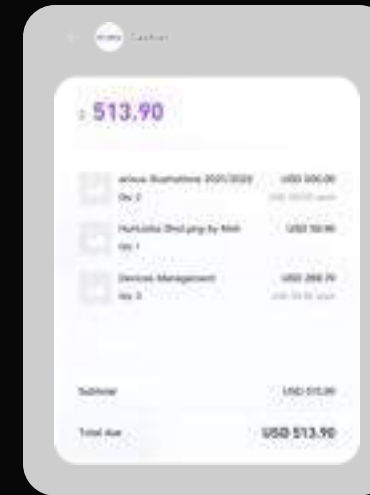

功能层

支付服务

调整INPUT框样式，优化交互样式/细节 达到更好的用户体验

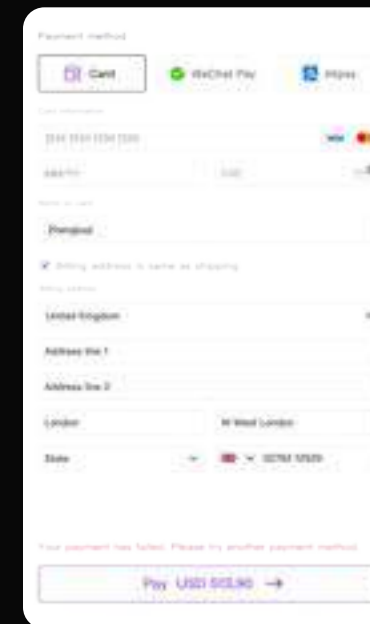

背景层

视觉+1

加入视觉元素，体现产品特性不强占主题



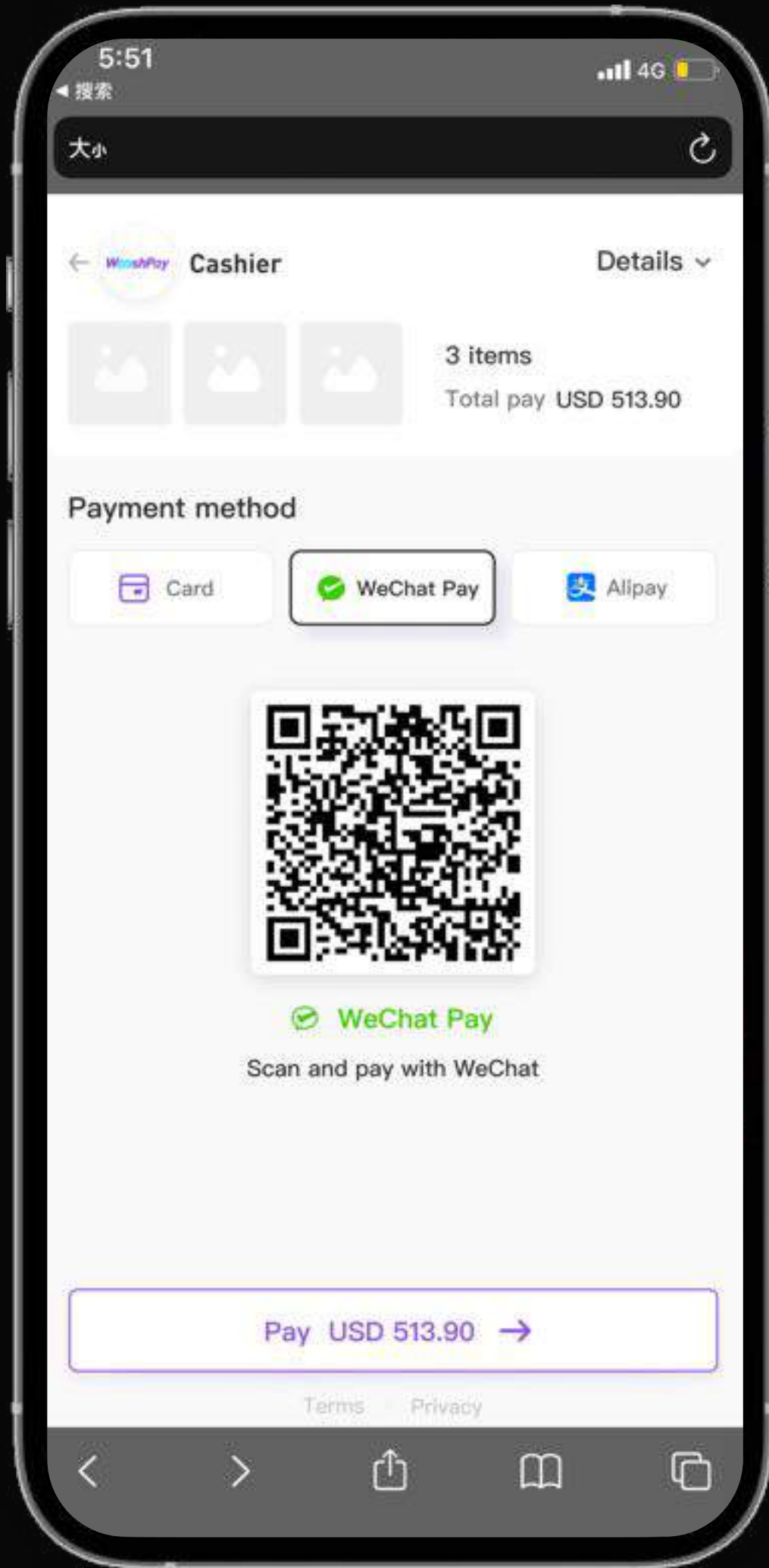
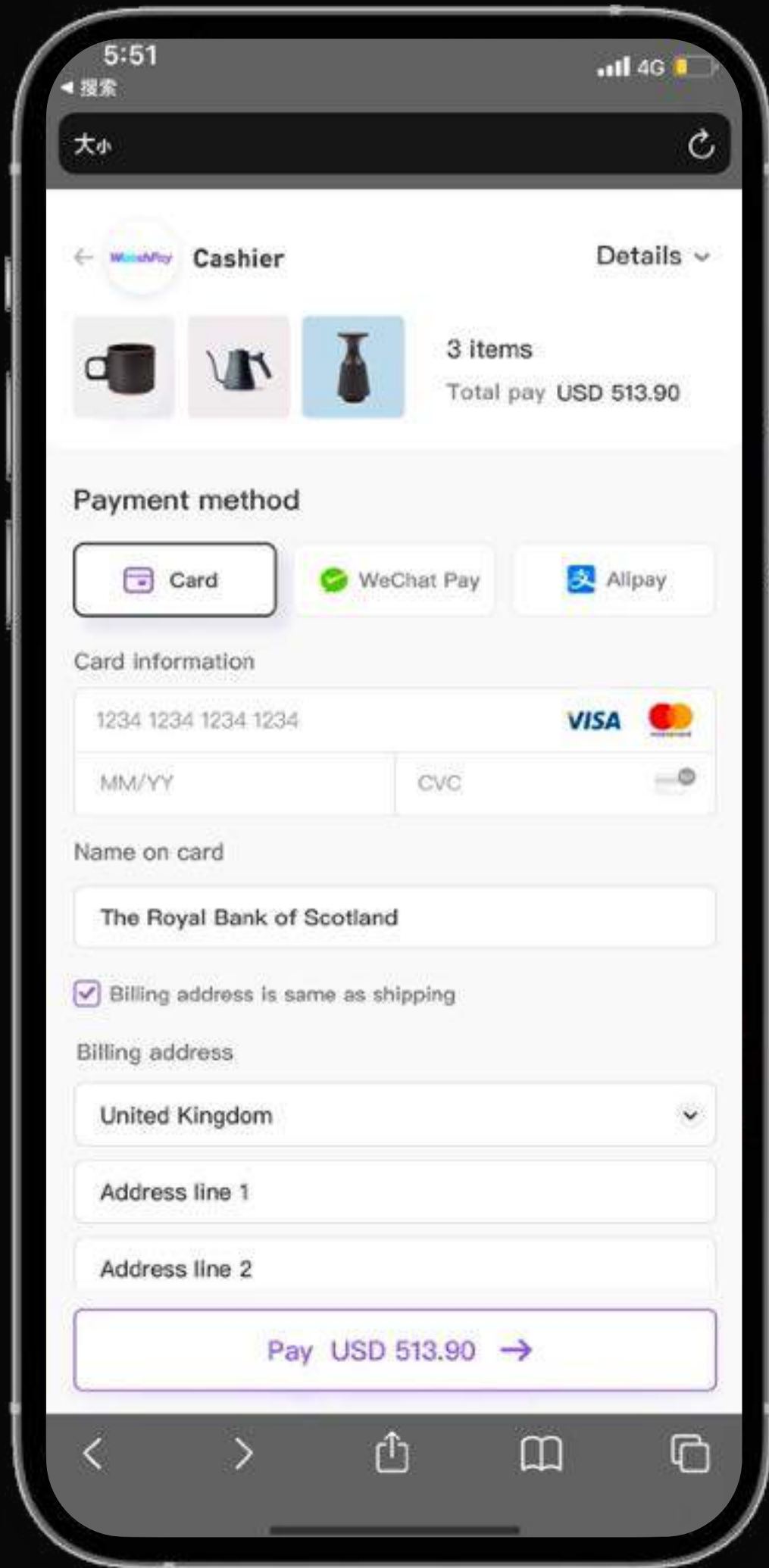

WOOSHPAY官网

针对分析优化 1.0

头部版块

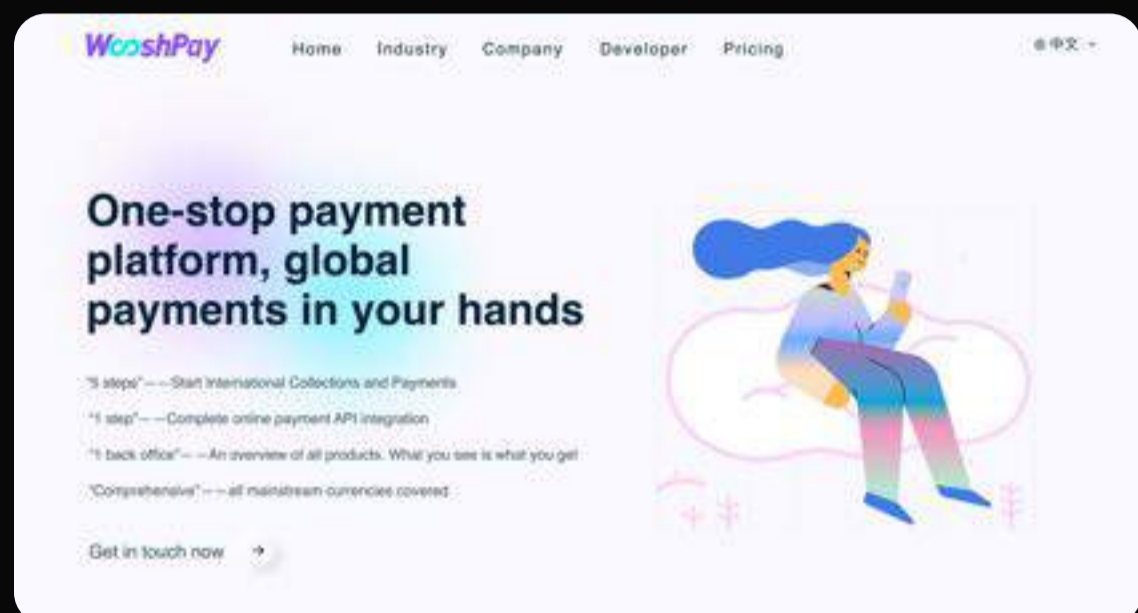

问题

1. 头部版块无法压住下方页面模块
2. 每有一套字体规范，样式混乱
3. 版块版块之间无分割，且版块含义诠释不足
4. 无风格...

针对性优化

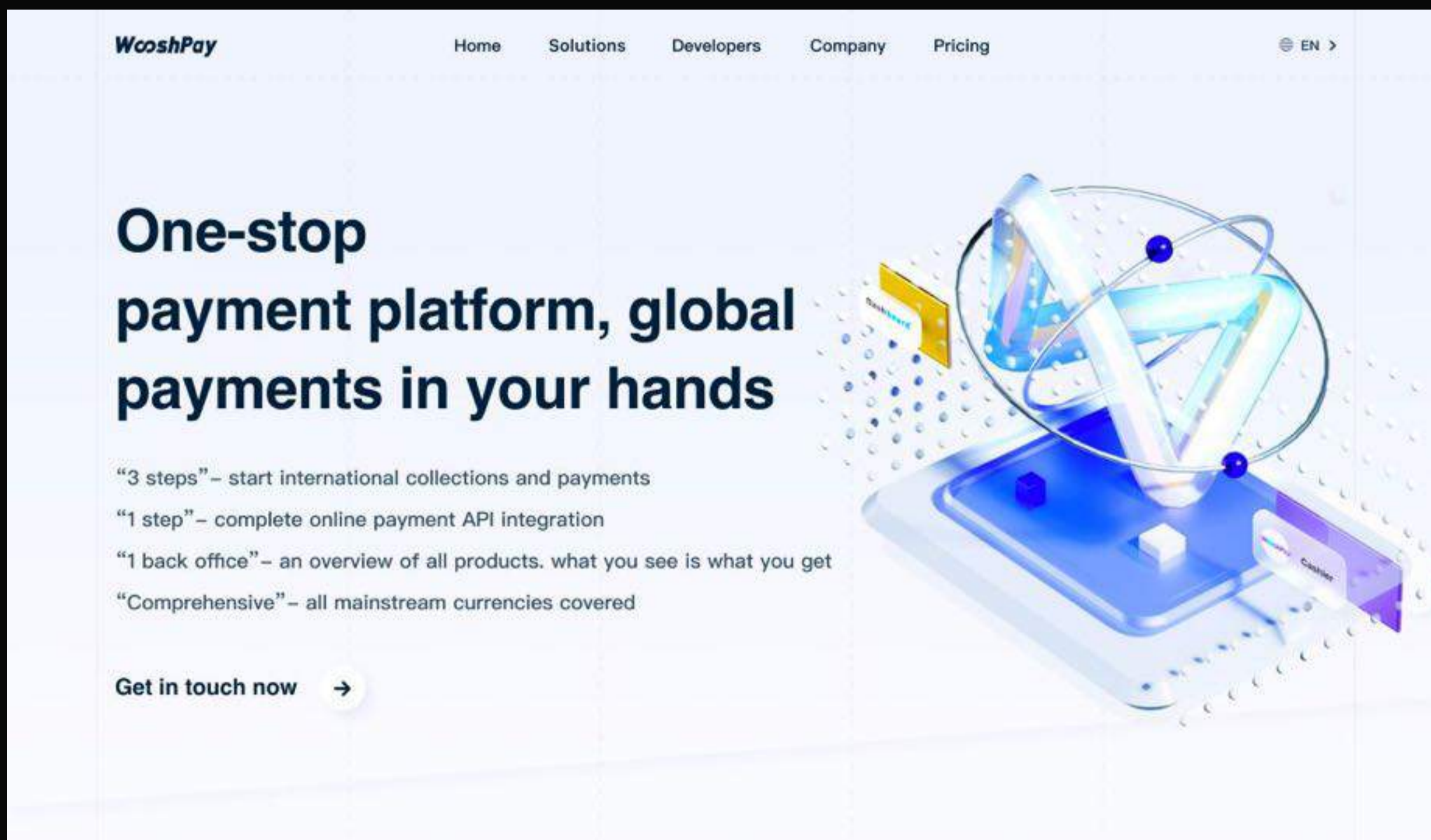

头部版块

字体样式规范

Grow your revenue

副文本 字体SF UI TEXT 18PX

Maximize conversion

模块大标题 字体HELVETICA 38PX

Flexible integrations

副标题 字体HELVETICA 26PX

Accept payments from customers around the

大标题副文本 字体SF UI TEXT 18PX

WooshPay offers 2 types of payment integration solutions

副标题副文本 字体SF UI TEXT 15PX

基础性排版

采用左文又图结构根据内容有一定区分

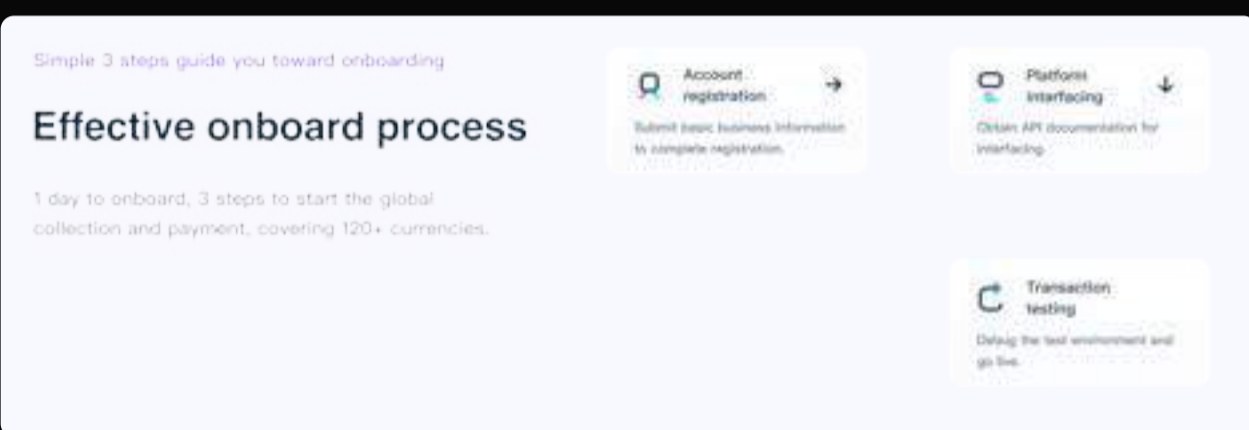

页面拓展

首页

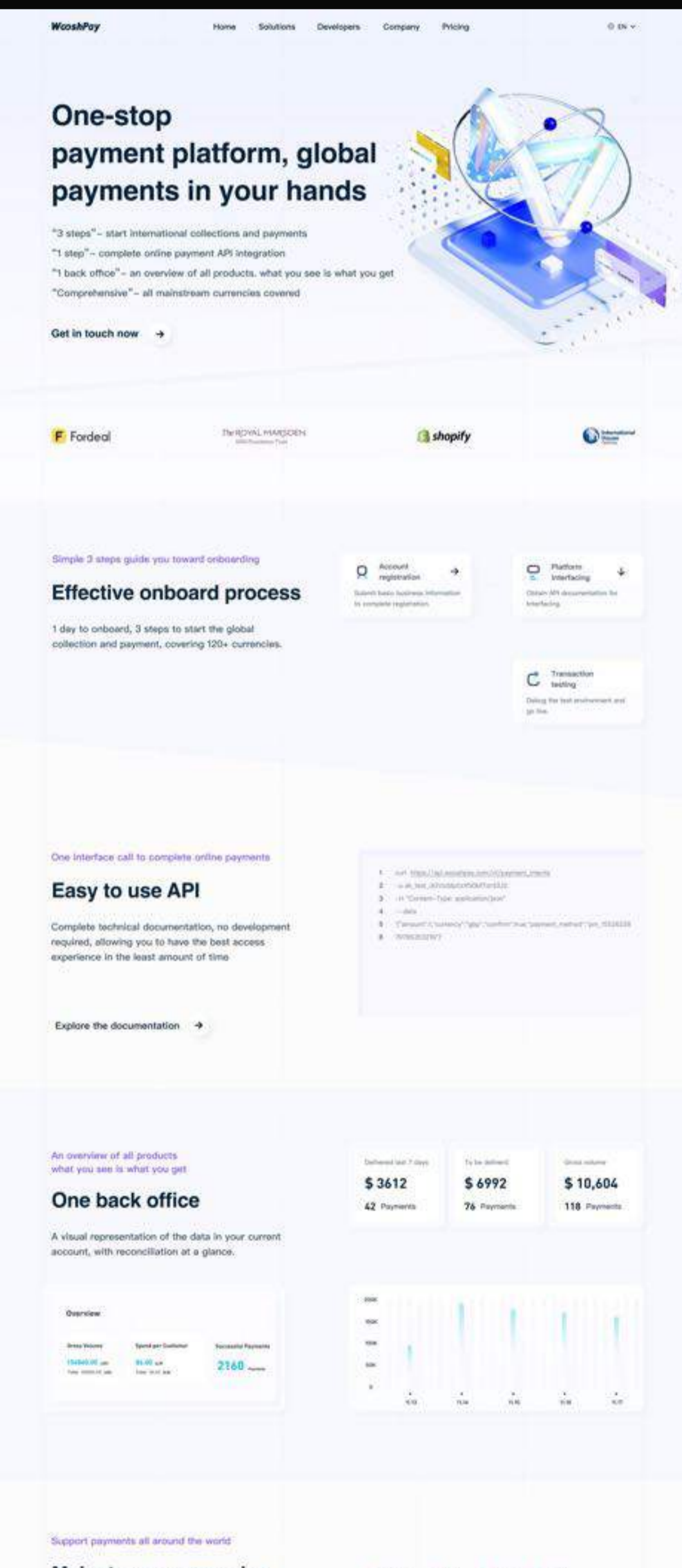

卡片样式

用于每个板块的载体

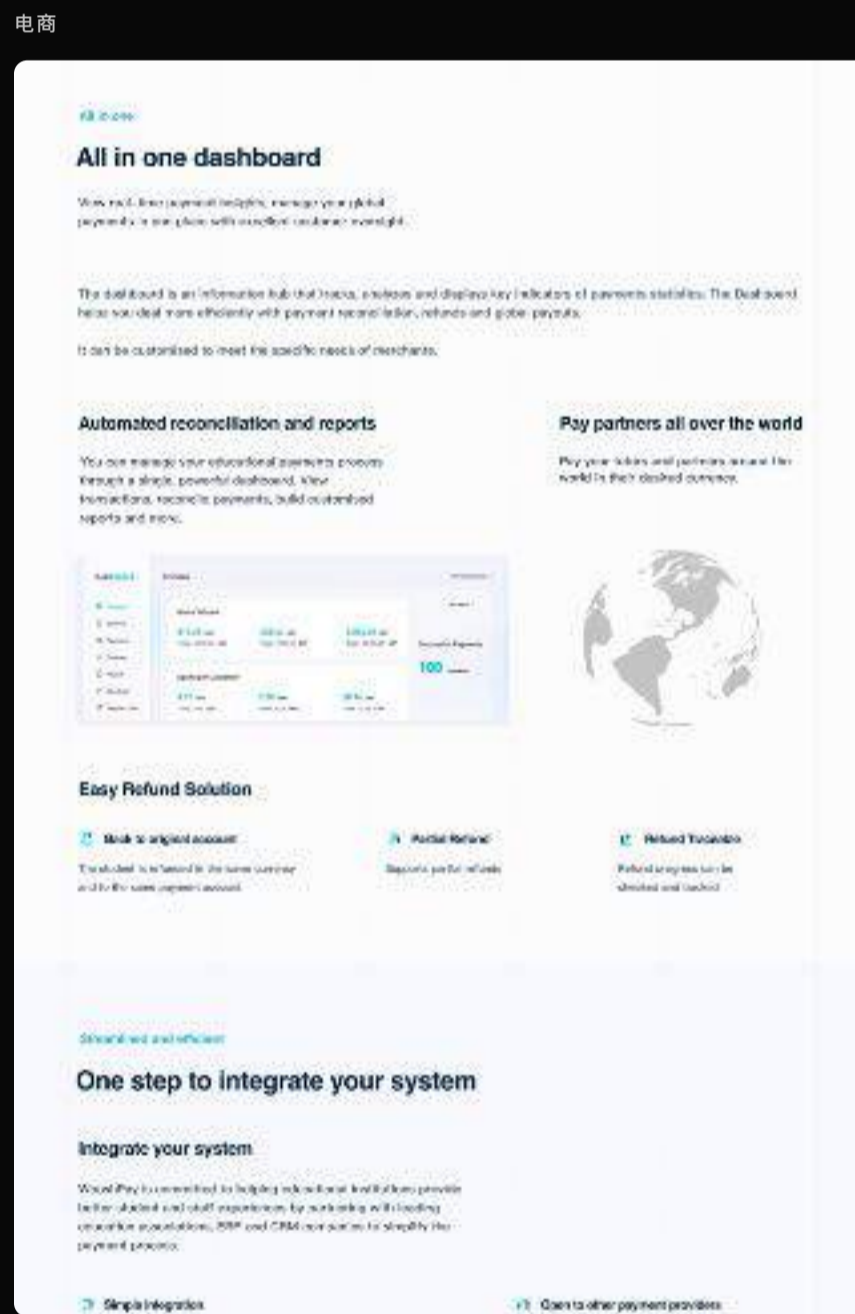
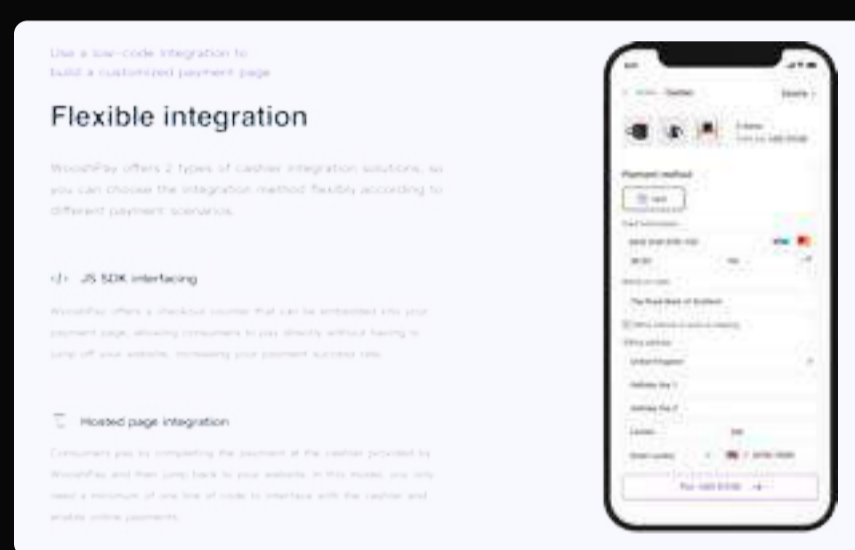

知识

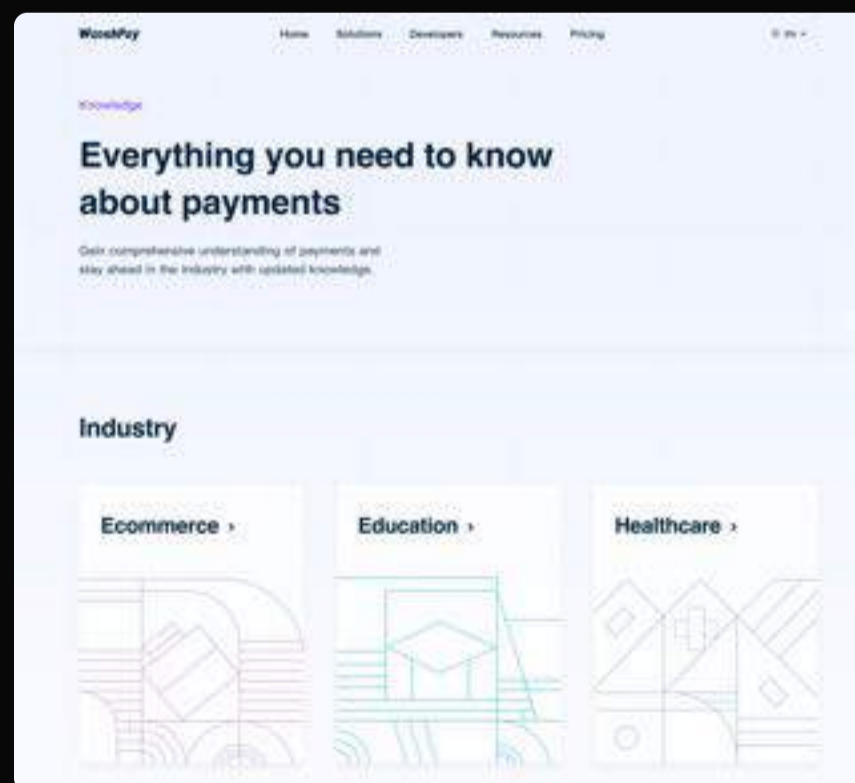

新闻



WOOSHPAY官网

针对分析优化 1.0

细节优化

交互细节

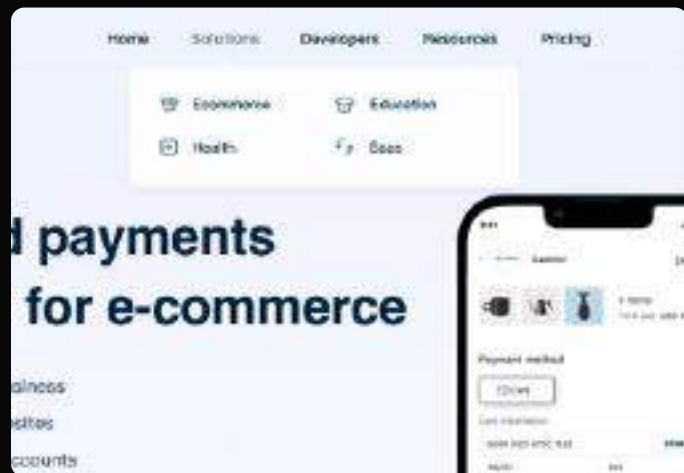

增加HOVER状态/悬浮交互效果

动效加入



根据产品内容加入动效是页面更生动



3D AI 1+

3D MODELING + AI FORM, IMPROVE THE PAGE VISUAL



3D建模+AI形式，提高页面视觉



线上体验地址<https://wooshpay.com/en>

3D

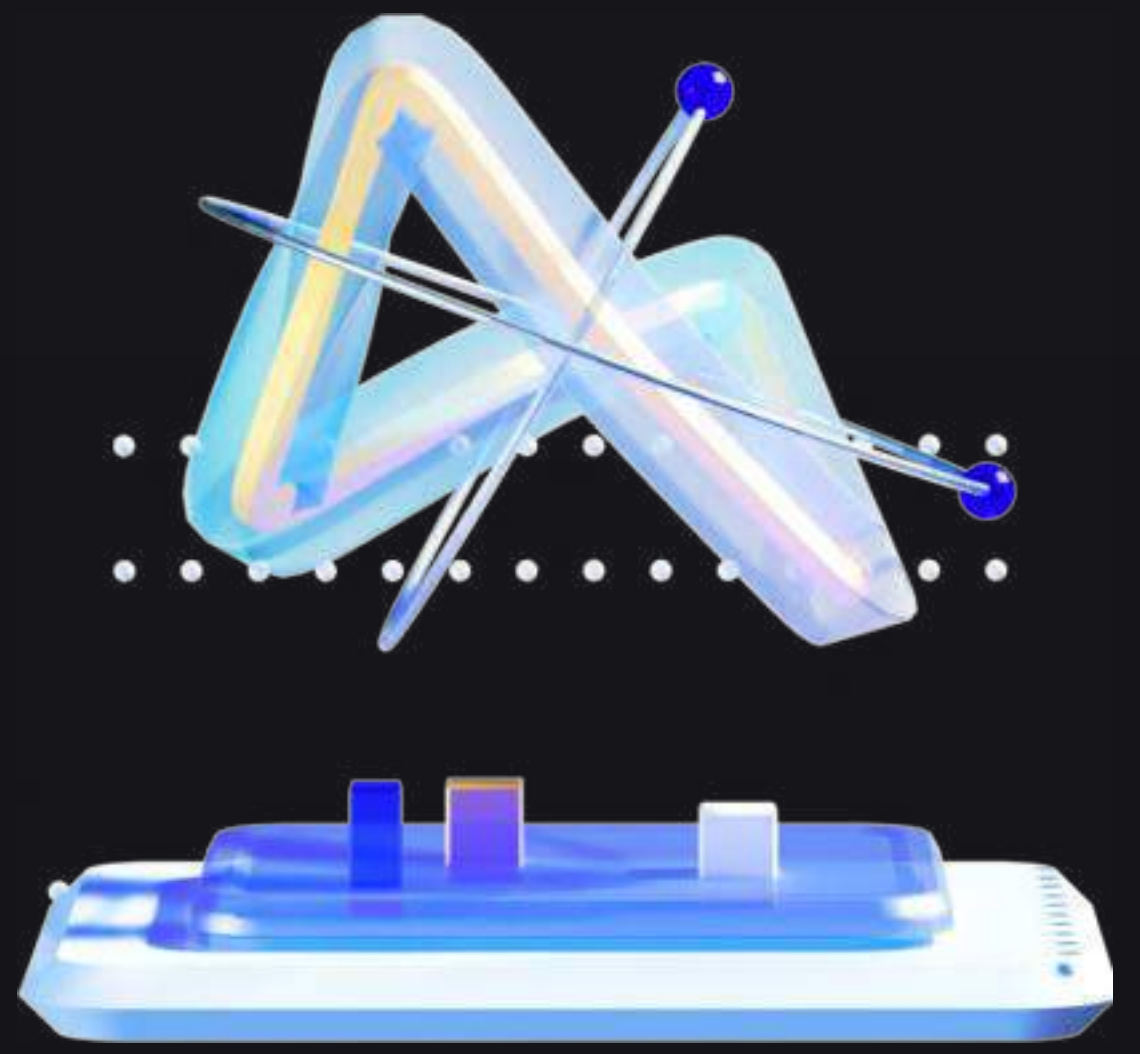
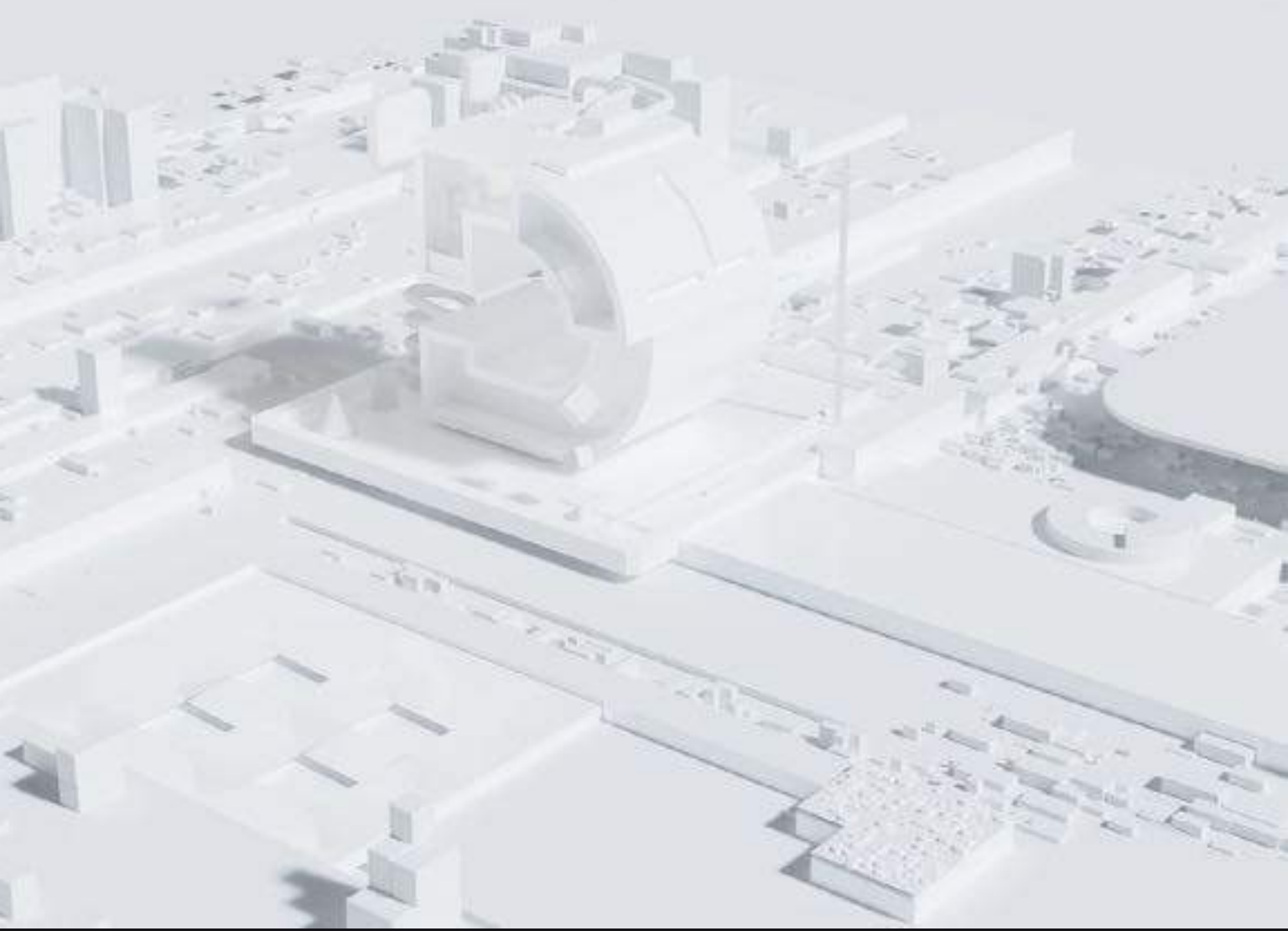
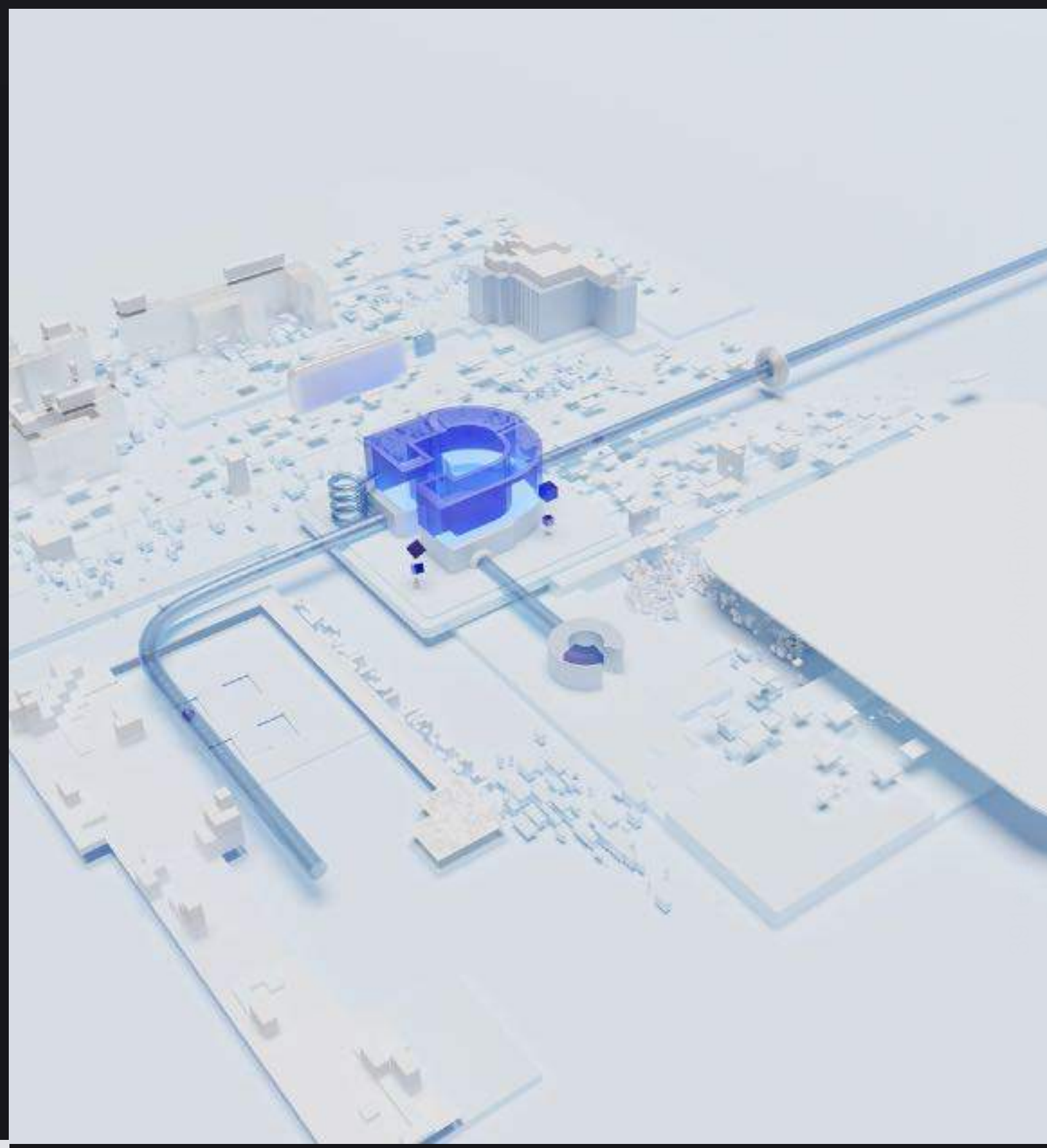
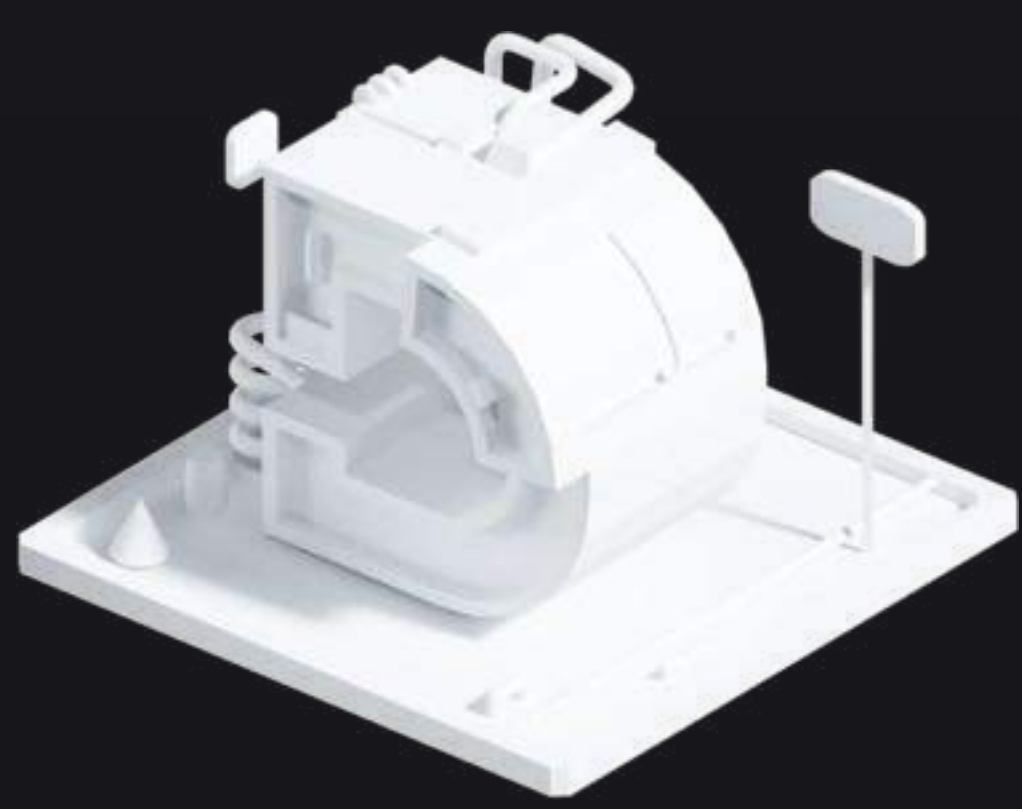

AI
3D_MODELING+

MECHANICAL PIKACHU OUT OF ACTION



KODA DUCK



INTERSTELLAR SPACECRAFT IN FLIGHT, SILVER WHITE TECHNOLOGY SENSE, DISK SHAPED MAIN HULL, CYLINDRICAL ENGINE

3D_MODELING+

MIDJOURNEY BOT



3D_MODELING+

MIDJOURNEY BOT



3D_MODELING+

MIDJOURNEY BOT

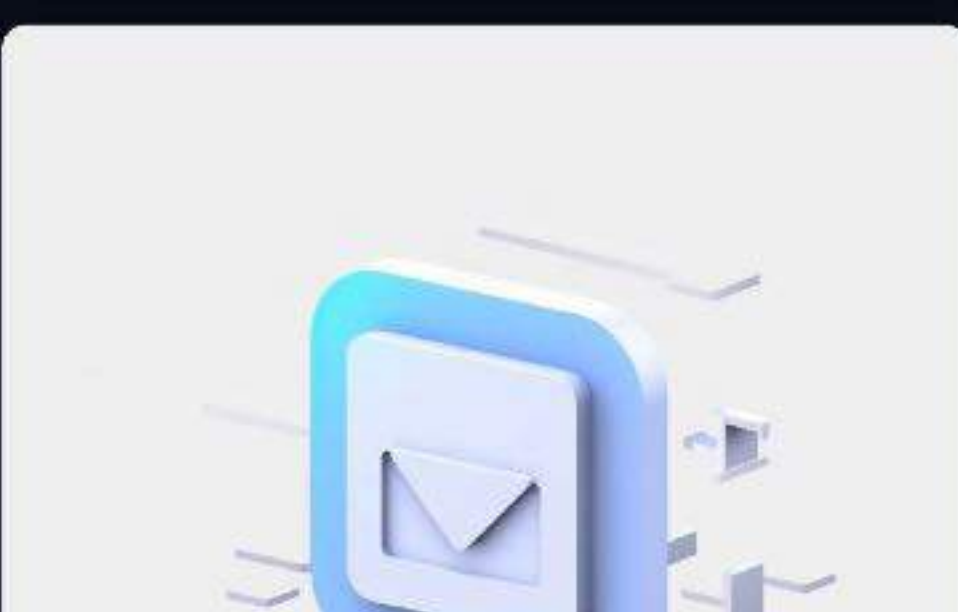

| + SASS平台

小程序 改版优化-系统组件

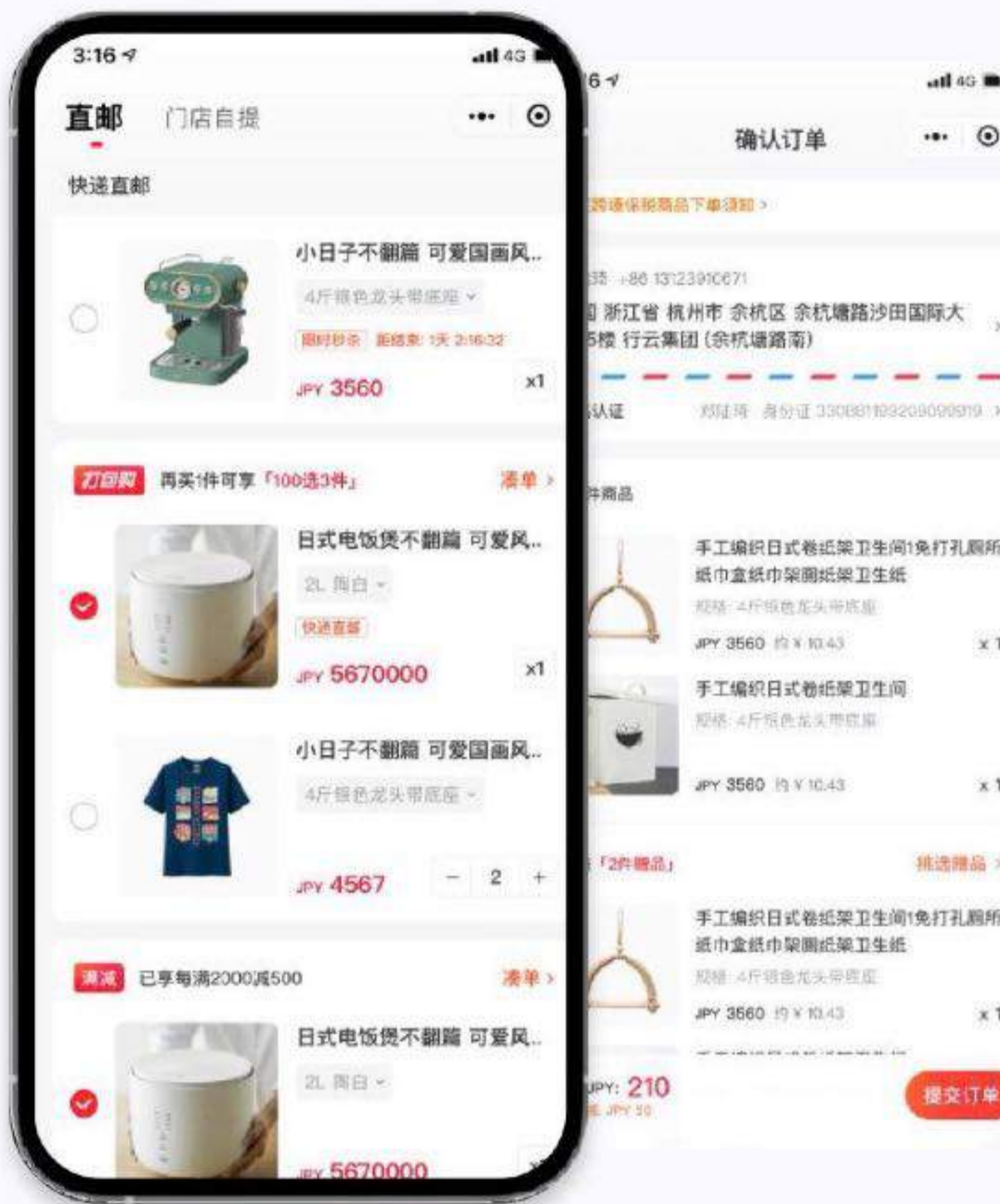

01 模块改版规划制定

根据产品特性制定改版规划和流程

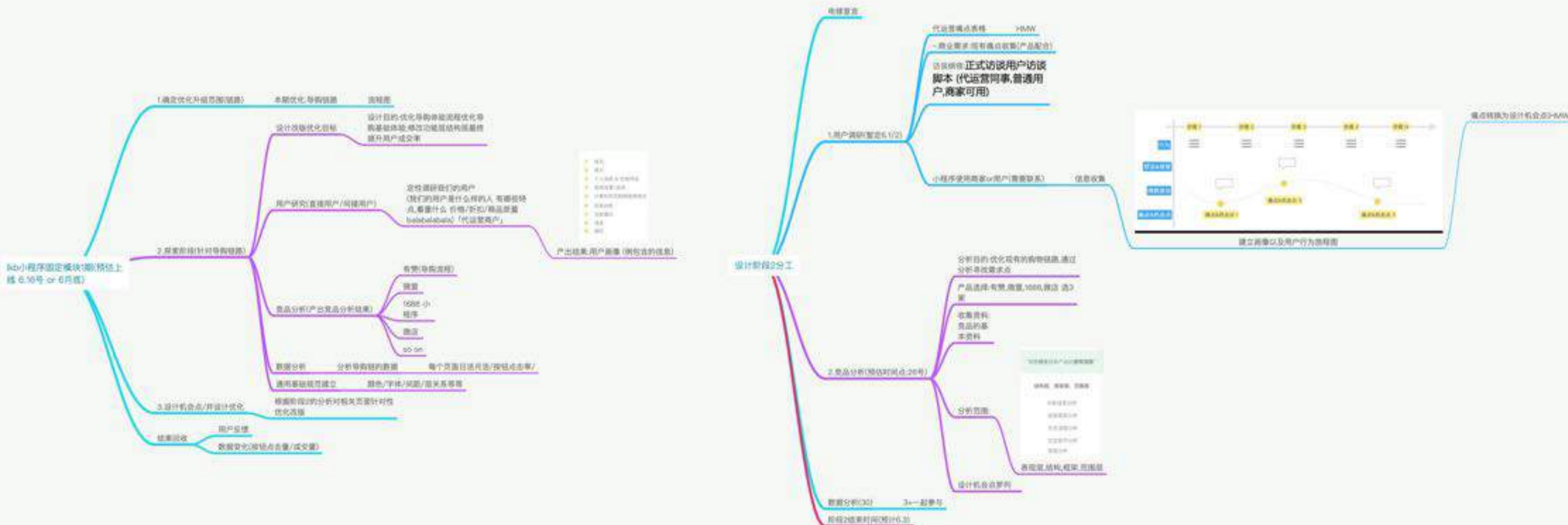

现有链路整理

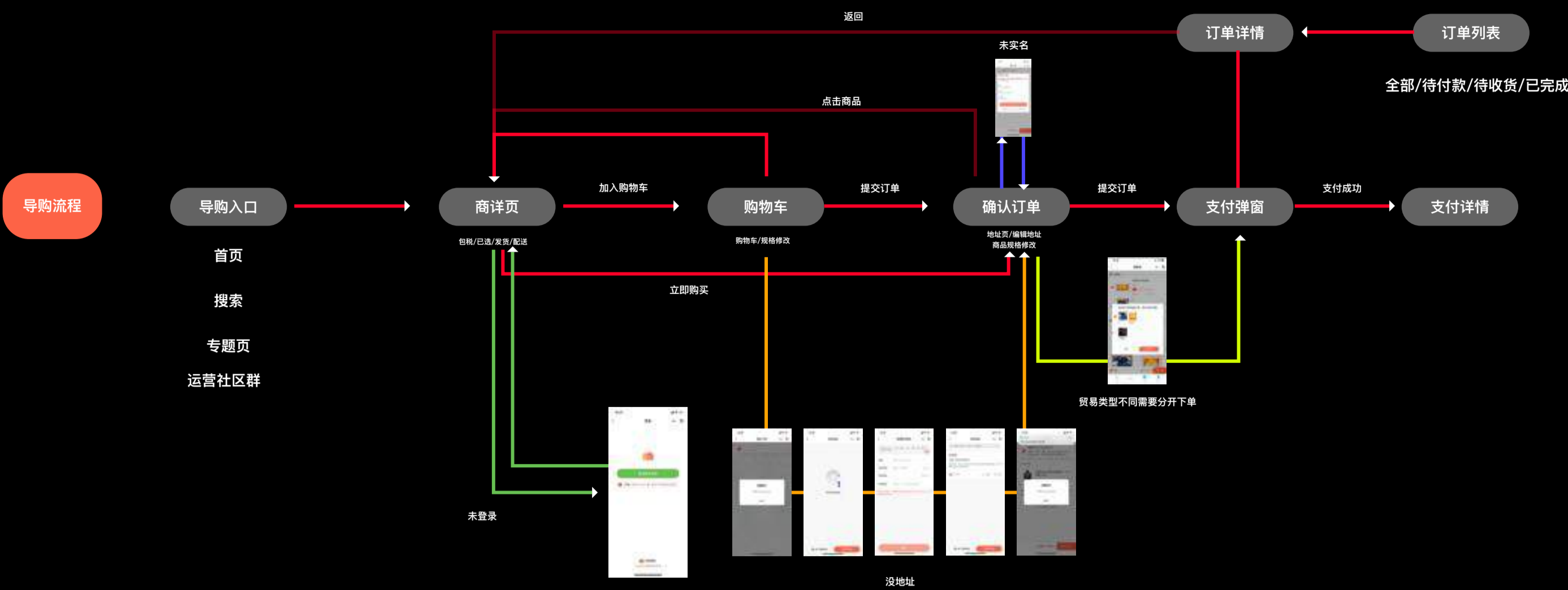

竞品分析 有赞

深耕垂直行业”这是未来有赞主要的策略。只要把行业做深了，才能更好地凸显出SaaS产品的价值

有赞规模/未来发展 未来的SaaS产品不再是单纯地给用户“解决方案”，客户成熟度在增加，未来业务场景不再单一。所有的行业在升级，用户需要的更多，对解决方案的需求也更精细化、更具有策略。



基本资料

商家选择有赞原因 目前较大程度上是因为它基于微信生态、快手、小红书等流量衔接，涨流量、涨粉 给商家足够的利益

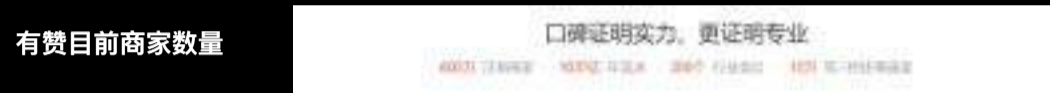

交互流程分析

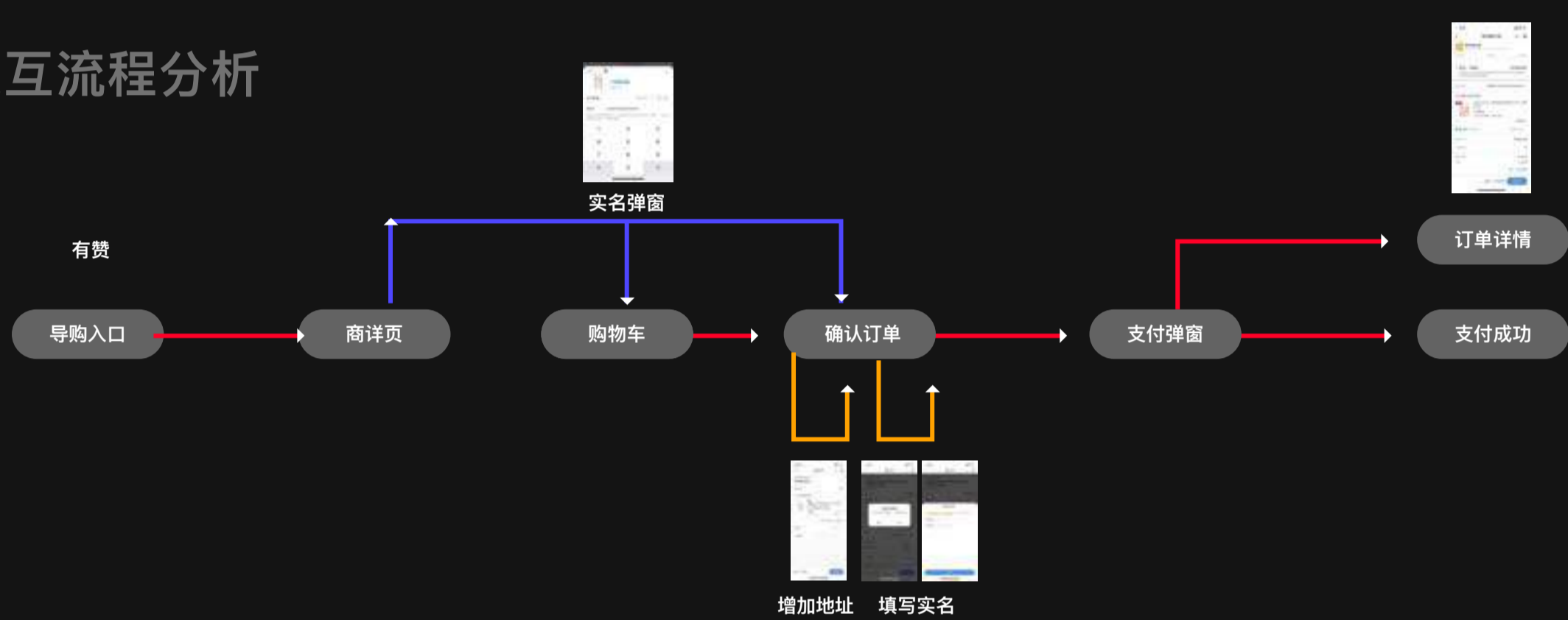

札幌

交互流程

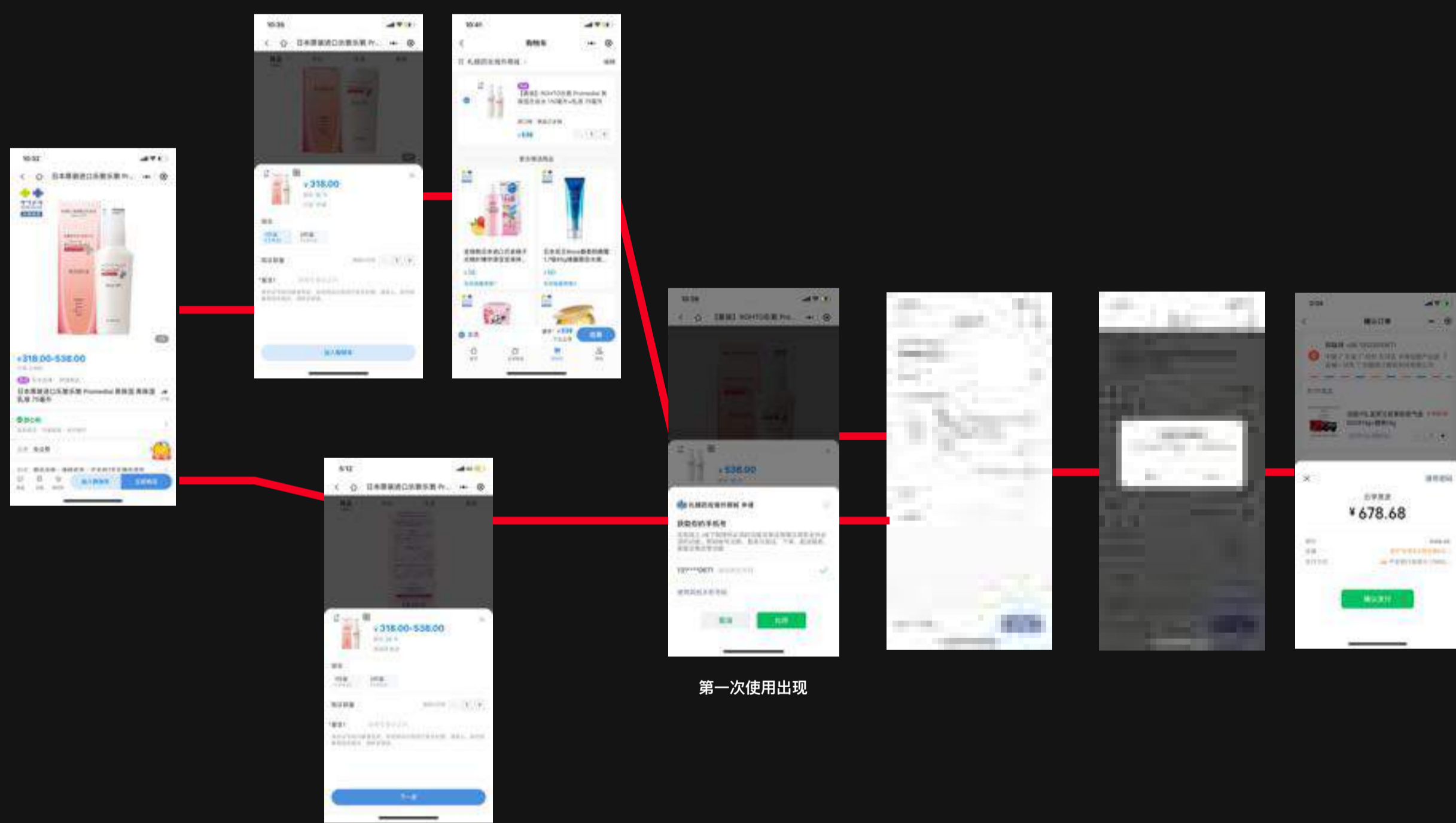

三越伊势

交互流程

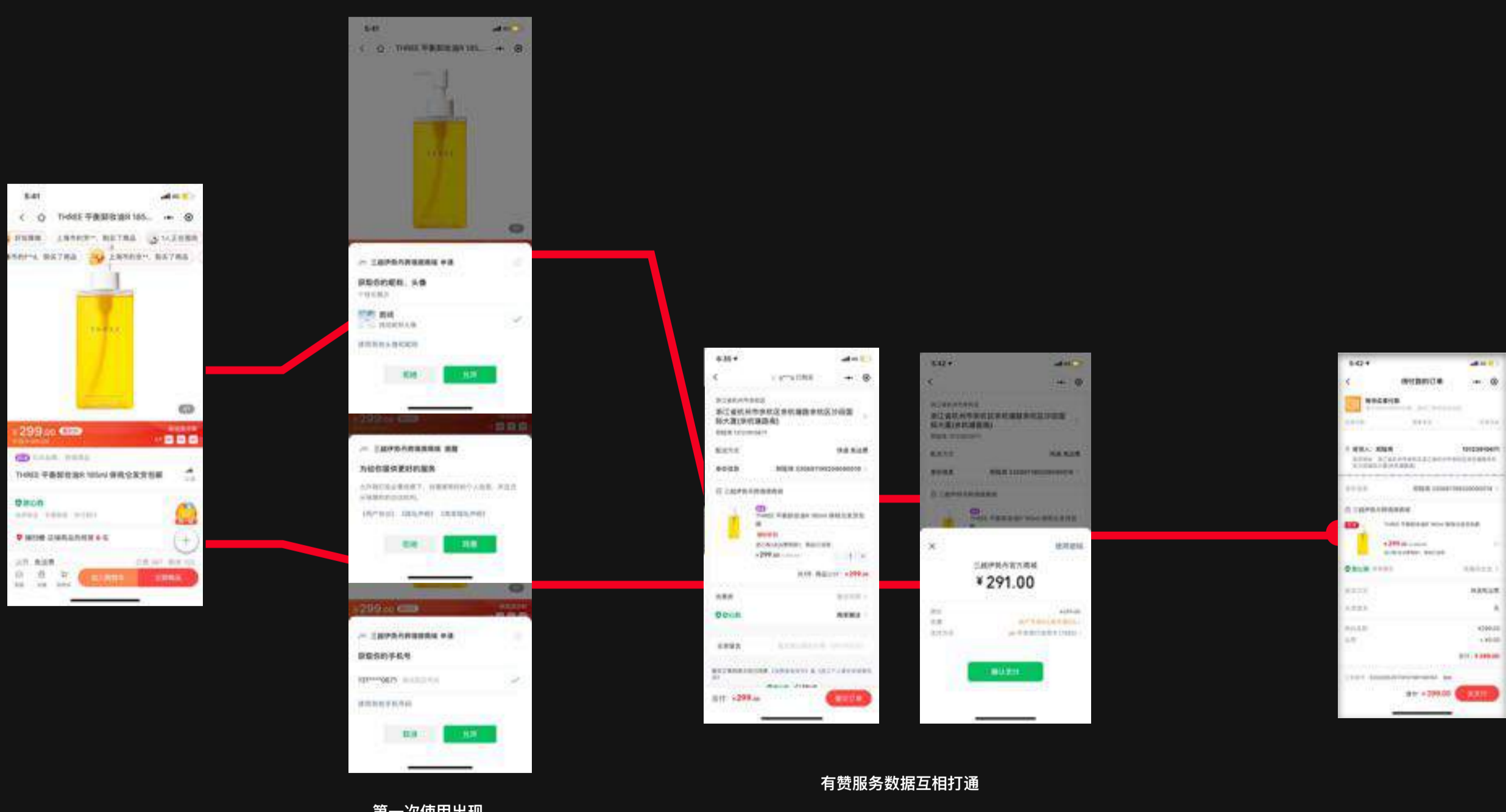

结果

基本流程都是 商详/购物车/确认订单/支付弹窗/支付结果

区别点在于实名方式,登录注册,和地址填写几个阶段

目前我们的流程略复杂,支线任务太多,新用户压力大,同时分开下单的方式对用户不友好

优化方向

用户登录/地址逻辑/下单方式

设计机会点整理 优化点

交互流程 用户登录/地址逻辑/下单方式交互流程优化

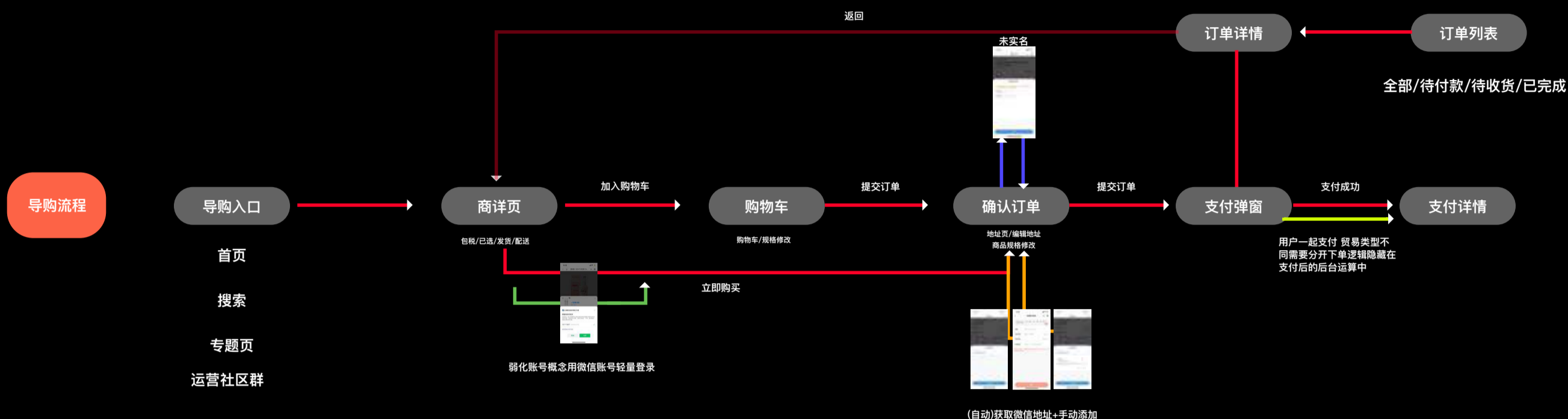

商详页优化

优化点



商品价格图片区块 信息点优化
加入优惠信息 海淘标签和信息

不同状态板式优化

附信息区,规格,发货方式,配送

分享功能 已售 横向弹幕功能

附信息 信息是否需要重构

加入评论功能

店铺+相关推荐

双列 大卡片展示
更多用户关注信息

底部栏

视觉优化

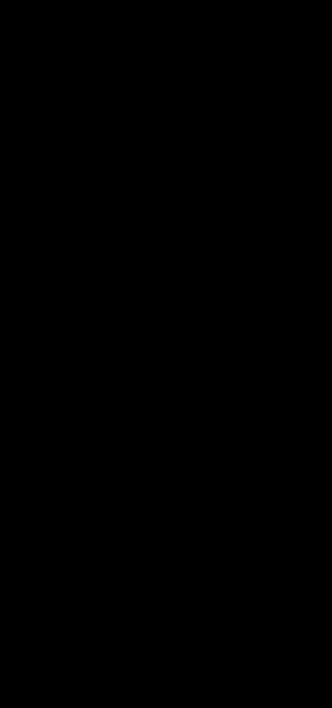
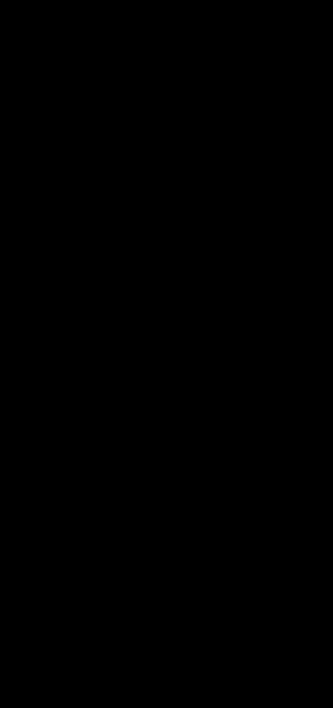
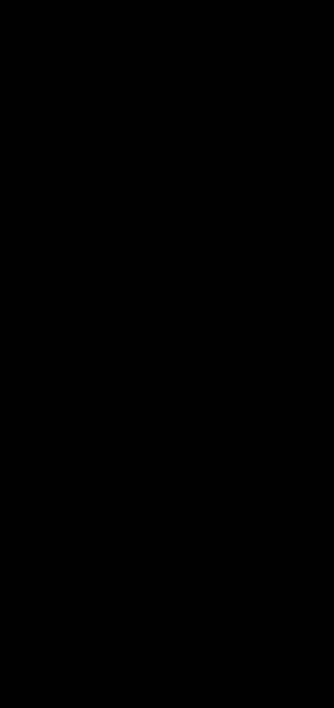
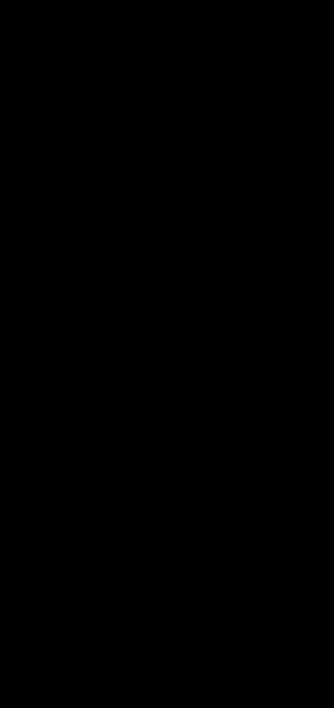
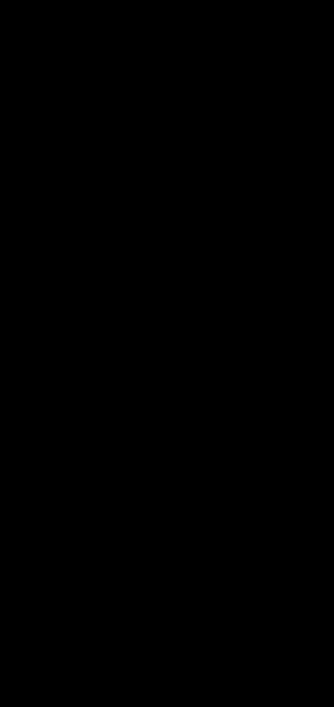

运营支持

支小镇 插画设计 动效demo设计 H5 战报 闪屏

01 支小镇 插画设计 2019

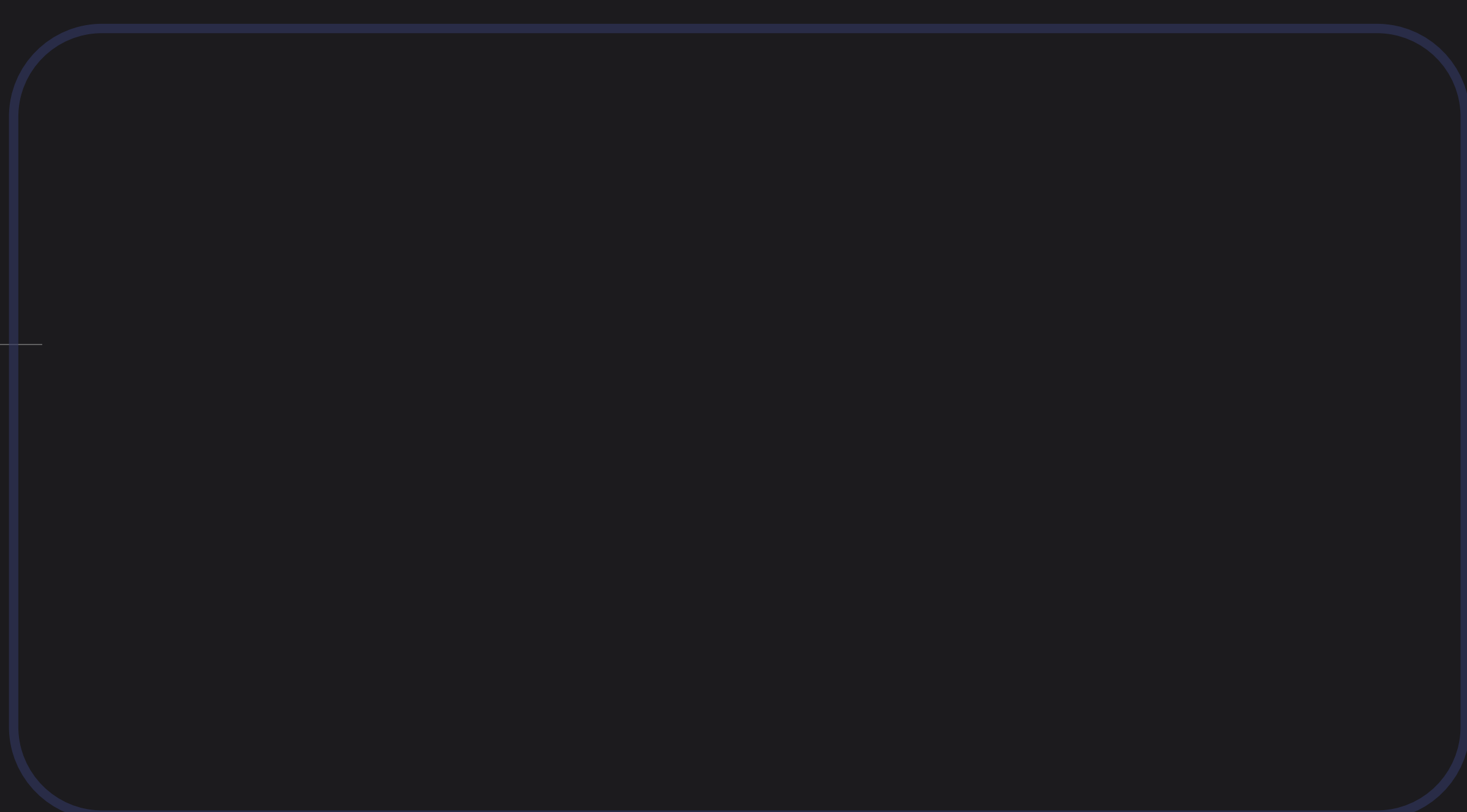

材质设计



2.5D 建筑视觉设计 I、II、III

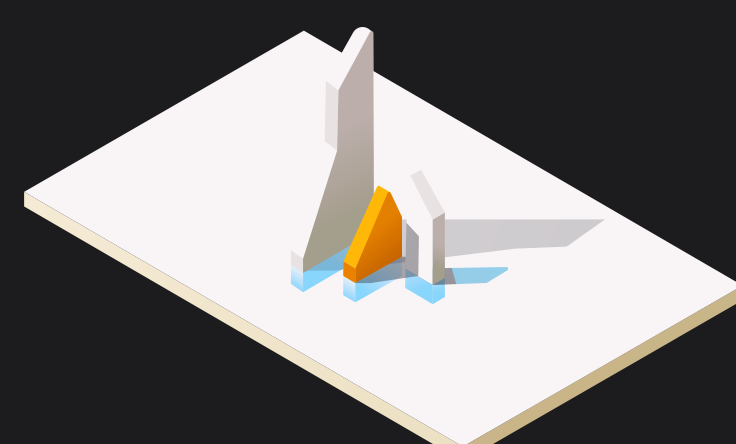
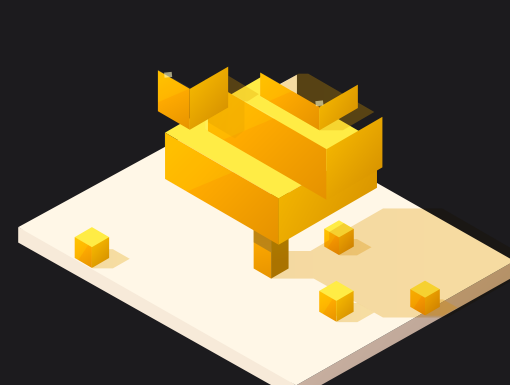



THANKS FOR WATCHING