

Name: _____

Static Electricity

Separate Physics Question Pack

Date: _____

Time: 1 hour 28 minutes

Total marks available: 88

Total marks achieved: _____

Q1.

Answer the question with a cross in the box you think is correct . If you change your mind about an answer, put a line through the box and then mark your new answer with a cross .

This question is about static electricity.

A student has a rubber balloon tied to a long piece of cotton thread.

The student gives the balloon an overall electrostatic charge.

(i) Describe **one** way that the student could give the balloon an overall electrostatic charge.

(2)

.....

.....

.....

.....

(ii) The student gives the balloon an overall negative charge.

Which of these sentences explains why the overall charge on the balloon is negative?

(1)

- A** Negative charge has been removed from the balloon.
- B** Negative charge has been added to the balloon.
- C** Positive charge has been removed from the balloon.
- D** Positive charge has been added to the balloon.

(iii) The student charges another balloon on a long thread.

Explain how the student can show that the two balloons have the same type of charge.

(3)

.....

.....

.....

.....

.....

.....

(Total for question = 6 marks)

Q2.

A battery sends a current through a metal wire.

(a) (i) Complete the sentence by putting a cross () in the box next to your answer.
Direct current is movement of charge

(1)

A backwards and forwards

B in many directions

C in one direction

D up and down

(ii) Complete the sentence by putting a cross () in the box next to your answer.

The particles that flow in the metal wire are

(1)

A atoms

B electrons

C protons

D neutrons

(b) The current in a wire is 3.7 A.

Calculate the charge that flows into the wire in 13 s.

(2)

.....
(c) Plastic is an insulator.

A student rubs a piece of plastic with a cloth.
This gives the plastic a negative charge.

(i) Explain how the plastic is charged by the rubbing.

(2)

.....
.....
.....
(ii) The cloth is also charged when it rubs against the plastic.

Describe the charge on the cloth.

(2)

.....
.....
.....
.....
(Total for Question is 8 marks)

Q3.

Answer the question with a cross in the box you think is correct . If you change your mind about an answer, put a line through the box and then mark your new answer with a cross .

A student gives a plastic strip an overall electric charge.

(i) Describe **one** way that the student can give the plastic strip an overall electric charge.

(1)

.....
.....

(ii) Figure 1 shows a gold leaf electroscope that can be used to investigate static electricity.

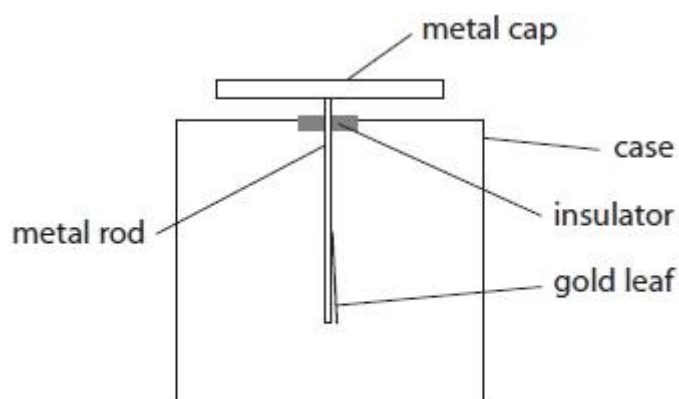

Figure 1

The electroscope has no overall charge.

The gold leaf has a very small mass and can bend very easily.

The student brings a negatively charged plastic strip near to the cap of the electroscope.

The gold leaf bends away from the metal rod.

Which diagram shows the way that electric charge is now distributed?

(1)

A B C D

(Total for question = 2 marks)

Q4.

Figure 3 shows two charged metal plates.



Figure 3

The top plate has a negative electric charge.

The bottom plate has a positive electric charge.

On Figure 3, draw the electric field lines between the two plates and show the direction of this electric field.

(Total for question = 2 marks)

Q5.

This question is about static electricity.

Draw on Figure 1 the shape and direction of the electric field due to the positive point charge.

(2)



Figure 1

(Total for question = 2 marks)

Q6.

Two small objects, P and Q, are each given an electric charge.

Figure 3 represents the electric fields around the objects, P and Q.

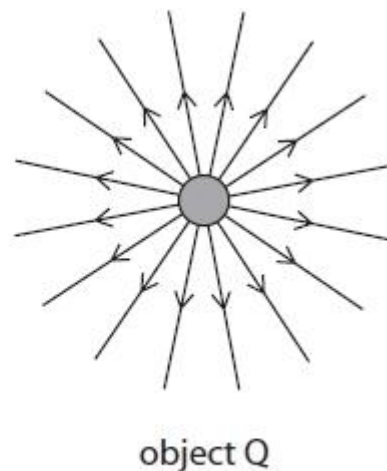
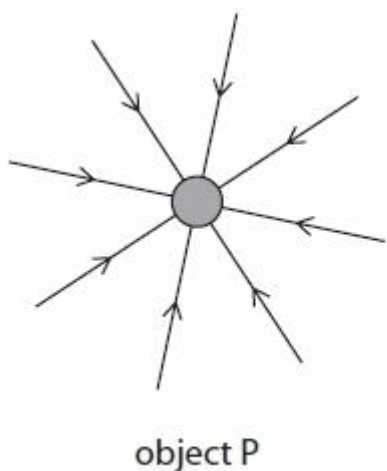

Figure 3

(i) Use information from Figure 3 to give **two** differences between the charge on P and the charge on Q.

(2)

1

.....

2

.....

(ii) Object P and object Q are held near to each other so that their electric fields interact with each other.

State the effect that the electric field of object Q has on object P.

(1)

.....

.....

(Total for question = 3 marks)

Q7.

An electrostatic air filter is designed to remove dust particles from the air in a room.

A fan blows dusty air past several metal rods and metal plates.

There is a large potential difference (voltage) between the metal rods and the metal plates.

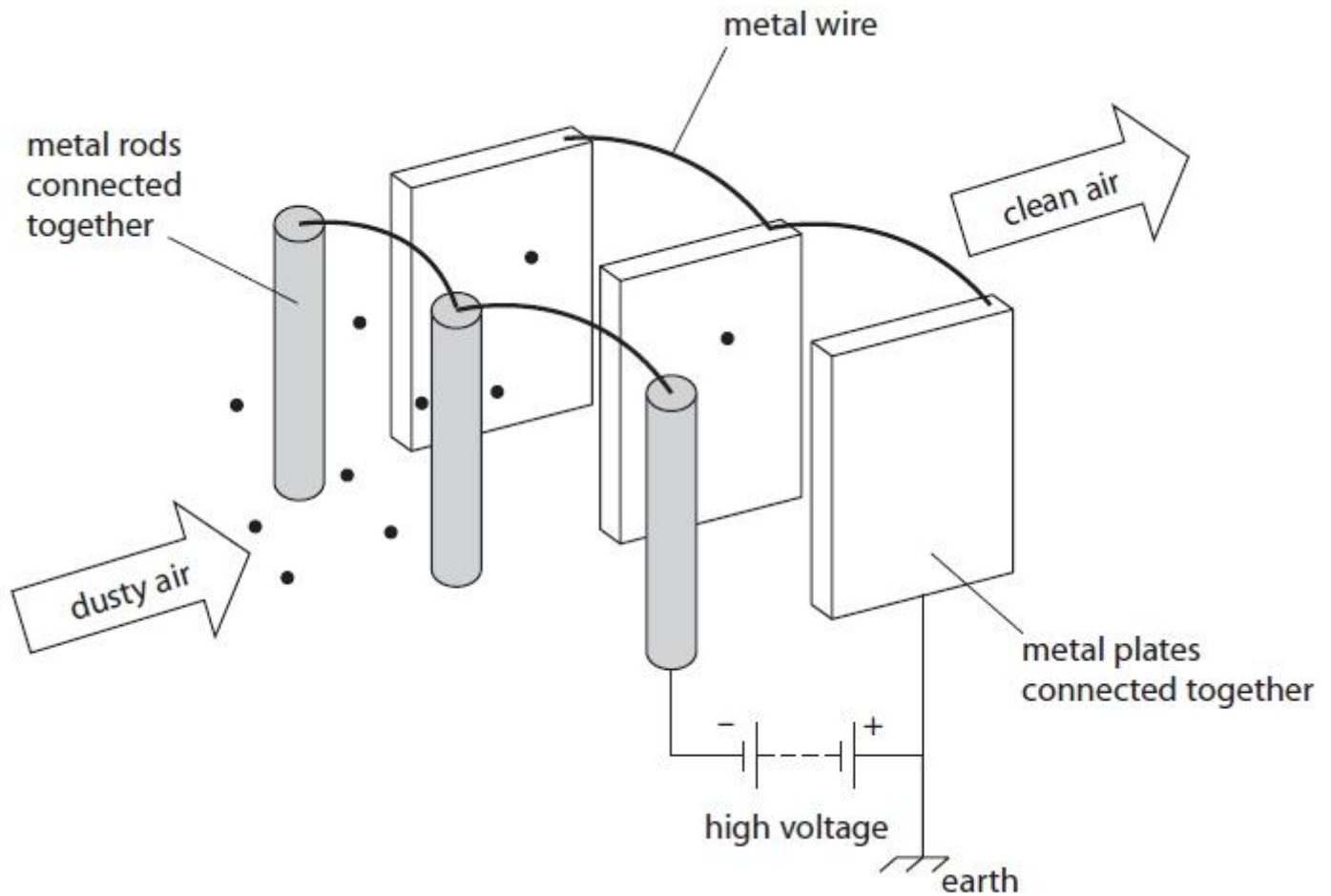

(a) Complete the sentence by putting a cross (☒) in the box next to your answer.

When dusty air goes past the metal rods, the dust particles become negatively charged.
This is because the dust particles

- A** lose electrons
- B** lose protons
- C** gain electrons
- D** gain protons

(1)

(b) When the dusty air flows past the metal plates, the dust particles settle on the metal plates.
Explain why the dust particles settle on the metal plates.

(2)

.....
.....
.....
.....

(c) (i) State what happens to the charge on the dust particles when they settle on the metal plates.

(1)

.....
.....

(ii) Explain why the charge does not build up on the metal plates.

(2)

.....
.....
.....
.....

(d) There is a current of 1.2 mA in the circuit.

Calculate the charge transferred by this current in 40 s.
State the unit.

(3)

charge transferred = unit:

Q8.

Figure 9 shows an electrostatic method for spray-painting a car door.

The car door has a negative charge.

The droplets of paint receive a positive charge as they leave the spray gun.



(Source: © Jens Brüggemann/123RF)

Figure 9

Explain how charging the door helps the paint to form an even coating on both sides of the door.

You should use ideas of forces and fields in your answer.

(2)

.....

.....

.....

.....

(Total for question = 2 marks)

Q9.

An insecticide sprayer charges droplets of insecticide.

Figure 2 shows the sprayer being used to spray a leaf.

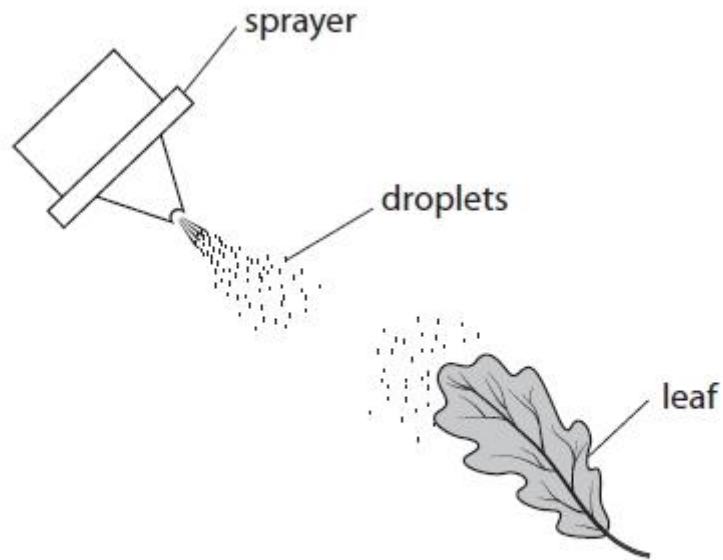

Figure 2

The leaf is connected to the ground (earthed).

Explain how charging the droplets helps to make sure that the leaf gets covered with insecticide.

You may add to Figure 2, including the sign (+ or -) of any charges, to help your answer.

(3)

.....

.....

.....

.....

.....

.....

.....

.....

(Total for question = 3 marks)

Q10.

Figure 2a shows another gold leaf electroscope that has been given an overall negative charge.

A student connects the metal cap of the charged electroscope to earth with a piece of wire as shown in Figure 2b.

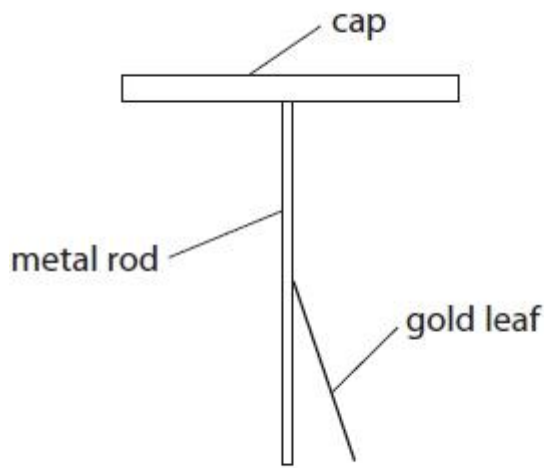

Figure 2a

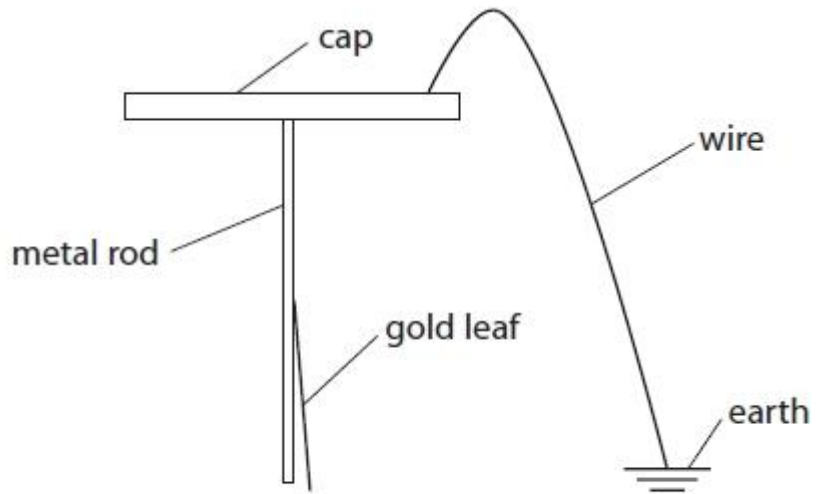

Figure 2b

Explain why the gold leaf has moved.

(2)

.....

.....

.....

.....

(Total for question = 2 marks)

Q11.

Explain how an aircraft can become electrically charged as it flies through the air.

(2)

.....

.....

.....

.....

(Total for question = 2 marks)

Q12.

A student rubs a plastic ruler against a woolly jumper.

The student tests the ruler and finds it has a positive charge.

Explain how the ruler becomes positively charged.

(2)

.....

.....

.....

.....

(Total for question = 2 marks)

Q13.

Answer the question with a cross in the box you think is correct . If you change your mind about an answer, put a line through the box and then mark your new answer with a cross .

This question is about static electricity.

Figure 9 shows a plastic block and a metal disc with an insulating handle.

The top surface of the plastic block has a negative charge.

The metal disc has no overall electric charge.

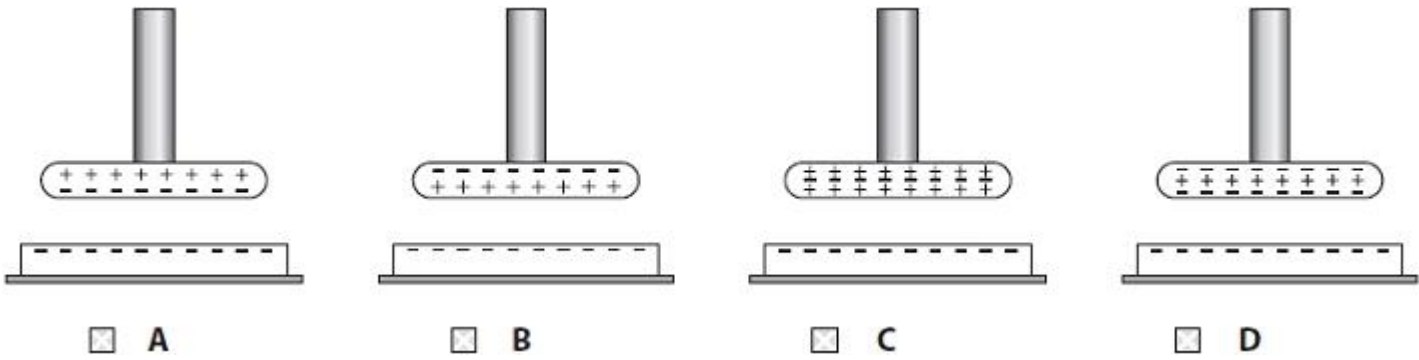

Figure 9

A student uses the insulating handle to hold the metal disc above the plastic block.

(i) Which of these diagrams shows how the charge is distributed on the metal disc?

(1)



(ii) The student keeps holding the metal disc above the charged plastic block and taps the metal disc with a finger.

This earths the metal disc for a short time.

Explain why the disc now has an overall positive charge.

(2)

.....

.....

.....

.....

(iii) Figure 10 shows the charges on part of the metal disc and the plastic block.

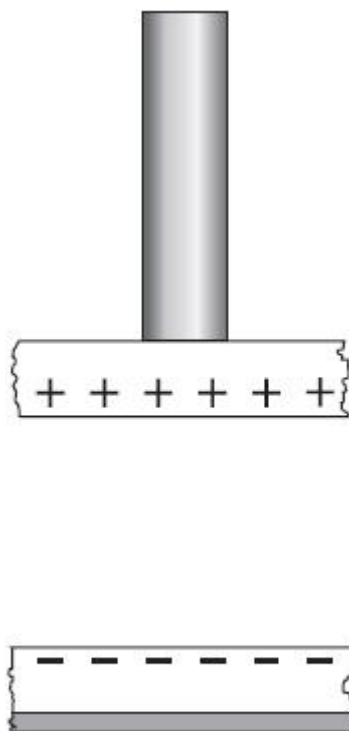

Figure 10

On Figure 10, draw lines to show the shape and direction of the electric field between the metal disc and the plastic block.

(2)

Q14.

Figure 7 shows two metal spheres.

Metal sphere A is fixed to a table.
Metal sphere B can be moved.

Metal sphere B is placed at a short distance from metal sphere A.

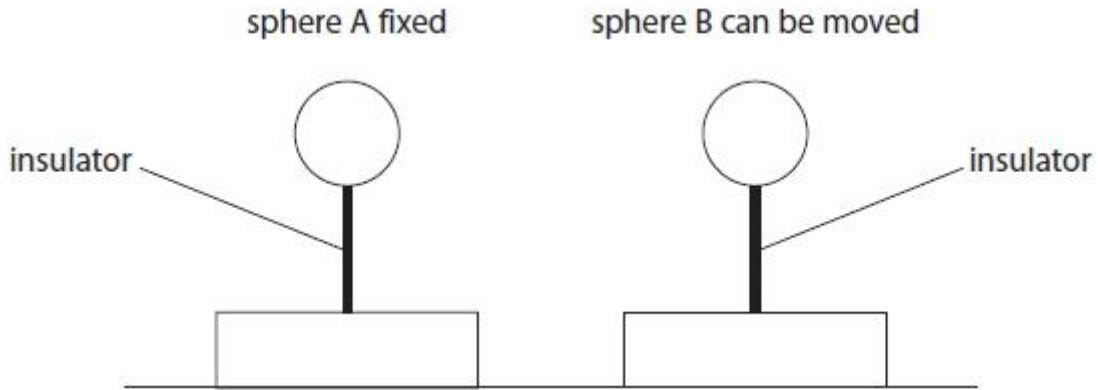

Figure 7

Both spheres are insulated from the table and given a negative charge.

The force between the charged spheres is measured.

(i) Explain, in terms of electric fields, why a force is exerted on sphere B.

(2)

.....

.....

.....

.....

(ii) Sphere B is moved and the force between the spheres is measured at several different distances.

Figure 8 is a graph of force on sphere B against distance between the centres of the spheres.

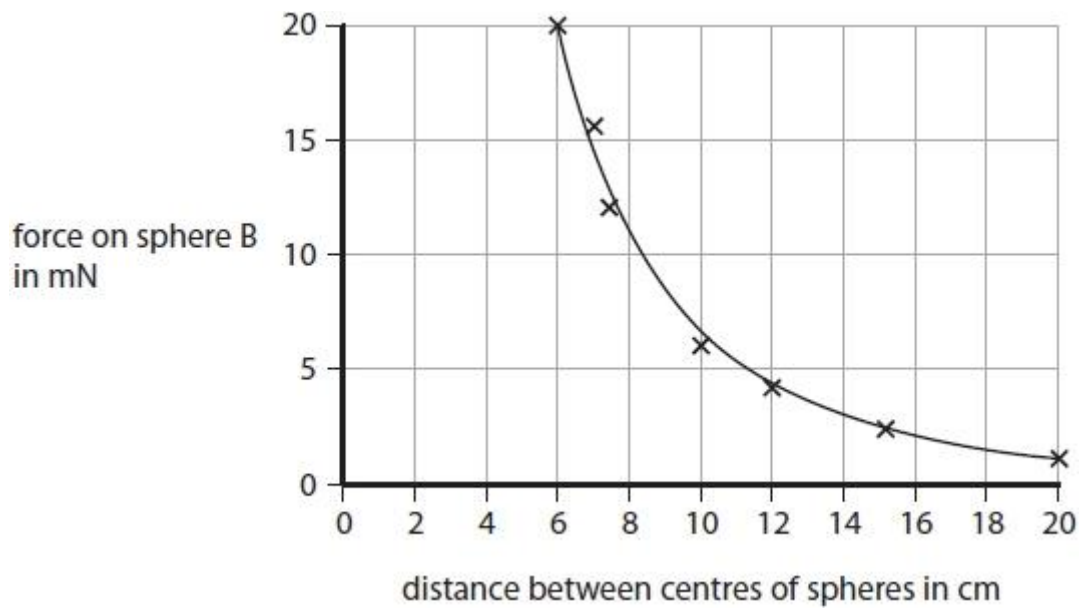

Figure 8

Describe how the force on sphere B varies with the distance between the centres of the spheres.

(2)

.....

.....

.....

.....

(Total for question = 4 marks)

Q15.

Figure 5 shows a metal chair being sprayed with paint.

The paint droplets come from a gun with an electric charge.

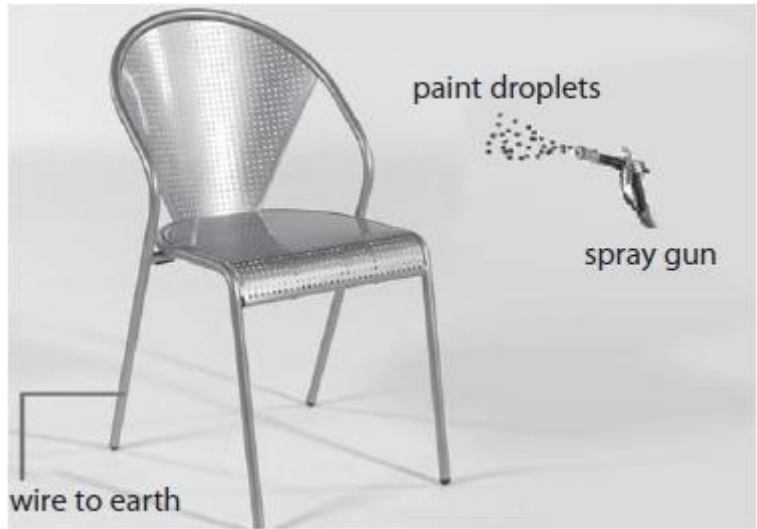

Figure 5

Inside the spray gun, electrons move along a charged wire towards the nozzle to charge the paint.

The charged paint droplets are sprayed from the nozzle.

The chair is connected to earth.

Which row of the table shows the correct combination of the charges as the charged paint droplets get near to the chair?

(1)

	paint droplets	chair
<input type="checkbox"/> A	negative	negative
<input type="checkbox"/> B	negative	positive
<input type="checkbox"/> C	positive	negative
<input type="checkbox"/> D	positive	positive

(Total for question = 1 mark)

Q16.

A battery sends a current through a metal wire.

Plastic is an insulator.

A student rubs a piece of plastic with a cloth.

This gives the plastic a negative charge.

(i) Explain how the plastic is charged by the rubbing.

(2)

.....

.....

.....
.....

(ii) The cloth is also charged when it rubs against the plastic.

Describe the charge on the cloth.

(2)

.....
.....
.....
.....

Q17.

A student rubs a plastic comb with a dry cloth to give the comb a positive electric charge.

Figure 6 shows the charged plastic comb picking up small pieces of paper.



(Source © GIPhotoStock/SCIENCE PHOTO LIBRARY)

Figure 6

(i) Explain how rubbing the comb with a dry cloth gives the comb a positive electric charge.

(3)

.....
.....
.....
.....
.....
.....

(ii) Explain how the positively-charged plastic comb picks up the small pieces of paper.

(3)

.....

.....

.....

.....

.....

.....

(Total for question = 6 marks)

Q18.

Glass is an insulator.

A student rubs a piece of glass with some silk.

The glass becomes positively charged.

(i) Explain how rubbing silk charges the glass.

(2)

.....

.....

.....

.....

(ii) The silk is also charged when it rubs against the glass.

Explain how the silk becomes charged.

(2)

.....

.....

.....

.....

(Total for question = 4 marks)

Q19.

Which of these diagrams shows the shape and direction of the electric field around a positive point charge?

(1)

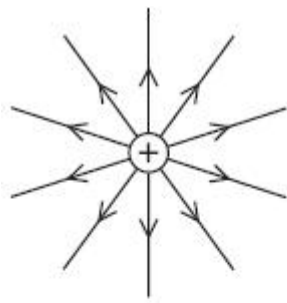

A

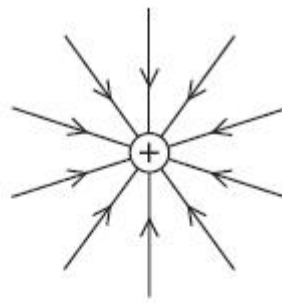

B

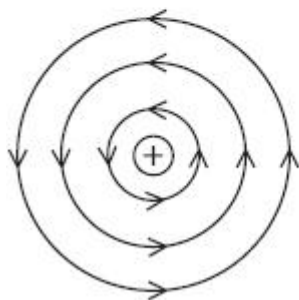

C

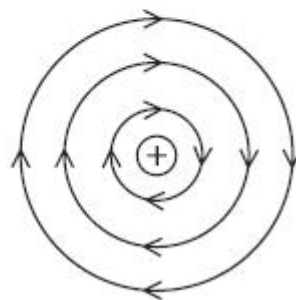

D

(Total for question = 1 mark)

Q20.

Figure 8 shows an airport worker refuelling an aircraft.



(Source: © Stanisław Tokarski/123RF)

Figure 8

Pumping fuel into an aircraft can be dangerous.

The worker connects an earth wire to the aircraft before pumping fuel.

Give **one** reason why earthing reduces the risk of fire.

(1)

.....
.....

(Total for question = 1 mark)

Q21.

(a) A student rubs a plastic rod with a dry cloth. The cloth becomes positively charged.

(i) Complete the sentence by putting a cross (☒) in the box next to your answer.

The cloth becomes positively charged because

(1)

- A** negative charge has moved from the cloth to the rod
- B** negative charge has moved from the rod to the cloth
- C** positive charge has moved from the cloth to the rod
- D** positive charge has moved from the rod to the cloth.

(ii) Two plastic strips are joined at the top and are hanging by a thread.

The student rubs both strips with another dry cloth.
The diagram shows the two plastic strips before and after the student rubs them.

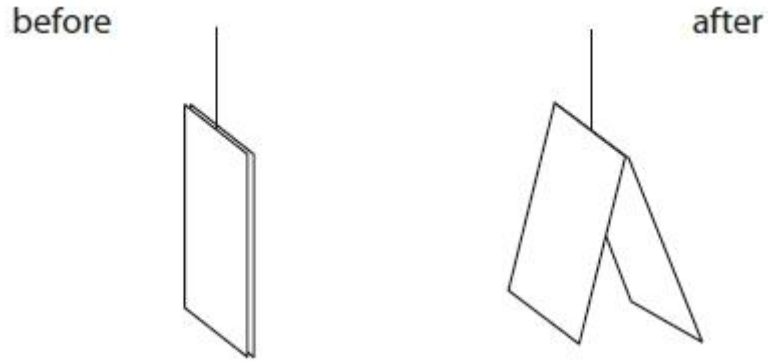

Explain why the strips behave in this way after they are rubbed with the cloth.

(2)

.....

.....

.....

.....

(b) The student reads an article about the possible build-up of static electricity during the refuelling of an aircraft.

(i) Explain why this build-up could be dangerous.

(2)

.....

.....

.....

.....

(ii) The article also states that the aircraft is connected by a metal cable to the ground. The aircraft is also connected by a metal cable to the refuelling tanker. Explain how these cables reduce the dangers when refuelling the aircraft.

(3)

.....

.....

.....

.....

.....

(Total for Question = 8 marks)

(i) Describe **one** situation where separation of electric charge can create a spark.

(2)

.....
.....
.....
.....

(ii) In a spark, the total charge of $0.22 \mu\text{C}$ (microcoulombs) flows in 2 ms (milliseconds).
Calculate the average current in that time.

(4)

average current = A

(Total for question = 6 marks)

Q23.

Answer the question with a cross in the box you think is correct . If you change your mind about an answer, put a line through the box and then mark your new answer with a cross .

Figure 1 shows a paint sprayer.

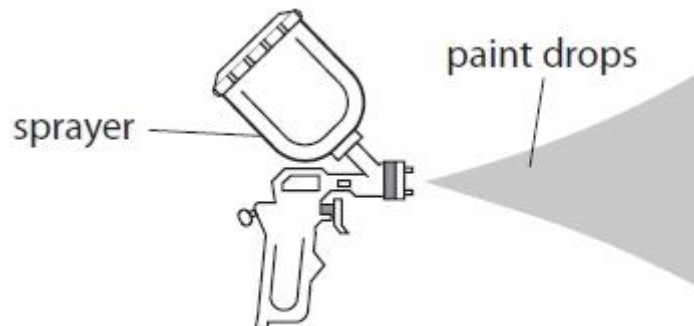

Figure 1

Some paint sprayers give the paint drops a positive charge as they leave the sprayer.

(i) The paint drops have a positive charge because the sprayer

(1)

- A removes electrons from the paint drops
- B adds electrons to the paint drops
- C removes protons from the paint drops
- D adds protons to the paint drops

(ii) Figure 2 shows the spray pattern from two different paint sprayers.



Figure 2

Sprayer X does not charge the paint drops. Sprayer Y gives the paint drops a positive charge. Explain how charging the paint drops changes the shape of the spray pattern.

(2)

.....

.....

.....

.....

(iii) Sprayer Y is used in a factory to paint a metal object.

The object hangs by a metal wire that is connected to earth. Explain why a metal wire is used to connect the object to earth.

(2)

.....

.....

.....

.....

(Total for question = 5 marks)

Mark Scheme

Q1.

Question number	Answer	Additional guidance	Mark
(i)	rub (the balloon) (1) with a piece of cloth/hair/fur (1)	use friction allow on any insulated object	(2)
Question number	Answer	Additional guidance	Mark
(ii)	B Negative charge has been added to the balloon A is incorrect removing negative charge would make the balloon positively charged. C and D are incorrect because positive charge cannot be moved		(1)
Question number	Answer	Additional guidance	Mark
(iii)	an explanation linking: method of handling balloons without discharging them (1) bring balloons near to each other (1) observation of repulsion (1)	hang balloons up by their strings they/balloons will push away (from each other)	(3)

Q2.

	Answer	Acceptable answers	Mark
(a)(i)	C		(1)
(a)(ii)	B		(1)
(b)	substitution (1) 3.7 x 13 evaluation (1) 48 (C)	48.1 Correct answer with no calculation scores 2 marks	(2)
(c)(i)	Correct responses can be seen in (i) or	["positive electrons/	(2)

	(ii) An explanation linking • <u>electrons</u> (1) and <u>one</u> of • removed by friction (1) • (transferred) <u>to</u> plastic (1)	protons moving", seen anywhere in part (i) or (ii) loses this mark] ignore reference to charge before rubbing transferred from cloth	
(c)(ii)	opposite to charge on plastic (1) <u>equal</u> to charge on the plastic (1)	charge on cloth is positive <u>same size</u> as charge on plastic electrons transferred from the cloth equal to electrons lost by cloth	(2)

Total question = 8 marks

Q3.

Question number	Answer	Additional guidance	Mark
(i)	use friction (1)	rub (the plastic rod)	(1) AO1

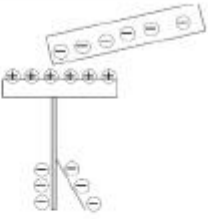
Question number	Answer	Additional guidance	Mark
(ii)	C  A and B are incorrect because the cap would become charged D is incorrect because the cap would have an opposite charge to that on the rod		(1) AO1

Q4.

Question number	Answer	Additional guidance	Mark
(i)	(size of) charge on Q is greater than (size of charge) on P (1) P has (overall) negative charge and Q has (overall) positive charge (1)	in any order Q has more charge / stronger field than P accept abbreviations such as + 've, - 've charge on P is opposite to charge on Q	(2) AO3

Question number	Answer	Additional guidance	Mark
(ii)	(force of) attraction on (object) P from (object) Q (1)		(1) AO1

Q7.

Question Number	Answer	Acceptable answers	Mark
(a)	C (gain electrons)		(1)

Question Number	Answer	Acceptable answers	Mark
(b)	An explanation linking <ul style="list-style-type: none"> • (Force of) attraction (1) • (plates have) opposite charge (to dust) (1) 	Plates have a positive charge Ignore different charge	(2)

Question Number	Answer	Acceptable answers	Mark
(c)(i)	transferred to plate / lost (1)	neutral / become discharged	(1)

Question Number	Answer	Acceptable answers	Mark
(c)(ii)	An explanation linking any two of <ul style="list-style-type: none"> • Metal is a conductor (1) • Electrons / (negative) charge moves (through the plates/ wire) (1) • Towards the voltage supply / earth /ground (1) 	Metal not an insulator Plates / charges are earthed	(2)

Question Number	Answer	Acceptable answers	Mark
(d)	Substitution: $Q = 1.2 \times 10^{-3} \times 40$ (1) Evaluation: 0.048 or 4.8×10^{-2} (1) C / coulombs (1)	Give 2 marks for correct answer with no working shown Unit mark is independent Allow for 1 mark 48 (with incorrect or no units) Allow for 2 marks 48 C Allow for all 3 marks 48 mC	(3)

Q8.

Question number	Answer	Mark
	<p>An explanation that combines identification – application of knowledge (1 mark) and reasoning/justification – application of understanding (1 mark):</p> <ul style="list-style-type: none"> (negatively charged) door attracts (positively charged) paint (droplets) (1) <p>Plus any one of the following:</p> <ul style="list-style-type: none"> therefore (positively charged) paint (droplets) follow lines of force and coat both sides of the car door (1) since electric field (or lines of force) directed towards the (car) door, then positive paint will move to the door (1) as electric field (or lines of force) touches all parts of the (car) door hence the positive paint will coat all parts of the door (1) 	(2)

Q9.

Question number	Answer	Additional guidance	Mark
	<p>an explanation including any three from:</p> <p>the leaf (becomes) charged (1)</p> <p>opposite to charge on droplets / spray (1)</p> <p>charges on leaf are induced (1)</p> <p>opposite charges attract (1)</p> <p>as a result of movement of electrons (between earth and leaf) (1)</p> <p>idea of spray reaching parts of the back of the leaf (1)</p> <p>charged droplets repel each other (having the same charge) (1)</p>	<p>accept marks scored on diagram</p> <p>ignore polarity for this marking point</p> <p>states charge opposite to what they have on the leaf</p> <p>ignore positive electrons / charges / particles</p> <p>allow all over</p>	(3) AO1.1

Q10.

Question number	Answer	Additional guidance	Mark
	<p>An explanation linking:</p> <p>electrons move_(1)</p> <p>with one from:</p> <p>(leaf and/or rod) have been discharged (1)</p> <p>(gold leaf) is no longer repelled (1)</p>	<p>negative charges move reject positive electrons for this mark</p> <p>to the earth</p>	<p>(2) AO1</p>

Q11.

Question number	Answer	Additional guidance	Mark
	<p>An explanation that combines identification – understanding (1 mark) and reasoning/justification – understanding (1 mark):</p> <ul style="list-style-type: none"> friction between aircraft and air (1) causes electron transfer between aircraft and air (1) 	<p>accept idea of air rubbing against wings ignore 'charge' and 'static'</p> <p>do not allow (for second mark) idea of protons moving</p>	<p>(2)</p>

Q12.

Question number	Answer	Additional guidance	Mark
	<p>an explanation linking any two from charged by friction (1)</p> <p>electrons / negative charges rubbed off ruler (1)</p> <p>woolly jumper becomes negative (1)</p>	<p>electrons / negative charges transfer to jumper</p> <p>ignore positive electrons / charges / particles</p>	(2) A02.1

Q13.

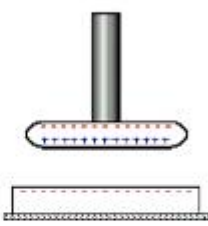
Question number	Answer	Additional guidance	Mark
(i)	<p>B</p>  <p>A and D are incorrect because a negative charge cannot induce a negative charge</p> <p>C is incorrect because the disc is insulated so negative charge cannot be removed</p>		(1)

Question number	Answer	Additional guidance	Mark
(ii)	<p>an explanation linking:</p> <p><u>electrons</u> / <u>negative</u> charges move/ flow/transfer (1)</p> <p>from the metal disc / to the student / to earth/ground (1)</p>	<p>reject positive charge moving for first mark</p> <p>accept lose electrons</p>	(2)

Question number	Answer	Additional guidance	Mark
(iii)	<p>at least three straight lines joining disc and plastic (1)</p> <p>arrow(s) from disc towards plastic (1)</p>	<p>judge by eye</p> <p>ignore curved lines at edge</p> <p>do not award mark if there are arrows in both directions</p>	(2)

Q14.

Question Number:	Answer	Additional guidance	Mark
(i)	<p>an explanation linking:</p> <p>sphere A has an electric field (1)</p> <p>sphere B is in it (1)</p>	<p>both spheres have electric fields</p> <p>the electric fields interact/overlap</p> <p>ignore nature of force; e.g. repulsion</p>	(2) AO 2 2

Question Number:	Answer	Additional Guidance	Mark
(ii)	<p>a description to include:</p> <p>as the distance increases the force (on the sphere B) decreases (1)</p> <p>the greatest change is at smallest distances (1)</p>	<p>negative correlation</p> <p>non-linear gradient changes</p> <p>allow named non-linear functions such as exponential / inversely proportional in this context</p> <p>reference to inverse square law scores 2 marks</p>	<p>(2)</p> <p>AO 3 1a</p> <p>AO 3 1b</p>

Q15.

Question number	Answer	Mark		
	<p>B</p> <table border="1" style="margin-left: 40px;"> <tr> <td style="width: 100px; height: 20px;">negative</td> <td style="width: 100px; height: 20px;">positive</td> </tr> </table>	negative	positive	(1)
negative	positive			

Q16.

	Answer	Acceptable answers	Mark
(i)	<p>Correct responses can be seen in (i) or (ii)</p> <p>An explanation linking</p> <ul style="list-style-type: none"> • <u>electrons</u> (1) and <u>one</u> of • removed by friction (1) • (transferred) <u>to</u> plastic (1) 	<p>["positive electrons/ protons moving", seen anywhere in part (i) or (ii) loses this mark] ignore reference to charge before rubbing transferred from cloth</p>	(2)
(ii)	<p>opposite to charge on plastic (1) <u>equal</u></p>	<p>charge on cloth is positive <u>same size</u></p>	(2)

	to charge on the plastic (1)	as charge on plastic electrons transferred from the cloth equal to electrons lost by cloth	
--	------------------------------	--	--

Q17.

Question Number:	Answer	Additional Guidance	Mark
(i)	<p>an explanation to link 3 of the following:</p> <p>friction (between cloth and comb) (1)</p> <p>transfer of electrons / charge {from plastic comb / on to the cloth} (1)</p> <p>electrons carry a negative charge (1)</p> <p>leaving excess positive charge on the comb (1)</p>	<p>reference to positive electrons or positive charge moving loses that mark point</p> <p>electrons/charges are rubbed off comb (on to cloth)</p> <p>leaving cloth with negative charge</p> <p>more protons than electrons (on the comb)</p>	(3) AO 2 1

Question Number:	Answer	Additional Guidance	Mark
(ii)	<p>an explanation linking:</p> <p>a negative charge is induced (1)</p> <p>on the part of the paper closest to the comb (1)</p> <p>opposite charges attract (1)</p>	<p>allow a clear description of induction</p> <p>ignore references to positive charge being moved in this context only</p> <p>force of attraction sufficient to pick up the pieces of paper</p>	(3) AO 2 1

Q18.

Question number	Answer	Additional guidance	Mark
(i)	An explanation that combines identification - understanding (1 mark) and reasoning - understanding (1 mark): charges move (1) because of friction (1)	(negative) electrons transfer glass loses electrons	(2)

Question number	Answer	Mark
(ii)	An explanation that combines identification - understanding (1 mark) and reasoning - understanding (1 mark): (negative) electrons are rubbed off the glass (on to the silk) (1) giving the silk a <u>negative charge</u> (1)	(2)

Q19.

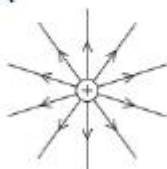
Question Number	Answer	Mark
	<p>A</p>  <p>The only correct answer is A</p> <p><i>B is not correct because the arrows are in the wrong direction</i></p> <p><i>C is not correct because the field is not circular</i></p> <p><i>D is not correct because the field is not circular</i></p>	(1) AO 1 1

Q20.

Question number	Answer	Mark
	The earth wire discharges the aircraft to prevent sparking which could ignite the fuel/cause a fire	(1)

Q21.

Question Number	Answer	Acceptable answers	Mark
(a)(i)	A - negative charge has moved from the cloth to the rod		(1)

Question Number	Answer	Acceptable answers	Mark
(a)(ii)	An explanation linking they repelled (1) (strips had) like charge (1)	push away same (type of) charge	(2)

Question Number	Answer	Acceptable answers	Mark
(b)(i)	An explanation linking any two from charges are separated (1) possibility of a spark (1) ignite the fuel (1)	ignore ref to electric shock pd between plane and ground cause fire / explosion	(2)

Question Number	Answer	Acceptable answers	Mark
(b)(ii)	<p>An explanation linking three from</p> <p>Metals are (good) conductors (1)</p> <p>Electrons/(negative) charge can flow through wire (1)</p> <p>charge goes from/to the ground / earth (1)</p> <p>discharge the tank/aircraft/pipes (1)</p>	<p>Reject flow of positive charge for this mark</p> <p>plane is earthed/grounded</p> <p>charge does not build up/dissipates</p> <p>Allow no pd between plane and ground so no spark possible for 2 marks</p>	(3)

(Total for Question = 8 marks)

Q22.

Question number	Answer	Additional guidance	Mark
(i)	<p>An answer that combines the following points of understanding to provide a logical description:</p> <p>the situation which caused the charge separation (1)</p> <p>where the spark travelled {from/to} (1)</p>	<p>examples:</p> <p>when refuelling, spark between end of {fuel/pipe} and vehicle =2</p> <p>spark {between/from/to} person comb/clothes/metal handle and, when combing hair/removing clothing/opening door = 2</p> <p>lightning flash, between cloud and cloud/plane/ground, =2</p> <p>ignore between plug and socket/jump leads</p>	(2)

Question number	Answer	Additional guidance	Mark
(ii)	unit conversion (1) $0.22 \mu\text{C} = 0.22 \times 10^{-6} \text{ C}$ and $2 \text{ ms} = 2 \times 10^{-3} \text{ s}$ substitution (1) $0.22 \times 10^{-6} = \text{current} \times 2 \times 10^{-3} \text{ s}$ rearrangement (1) $\text{current} = 0.22 \times 10^{-6} / 2 \times 10^{-3}$ evaluation (1) $1.1 \times 10^{-4} \text{ (A)}$	substitution and re-arrangement in either order both needed award full marks for correct answer without working power of ten error only loses one mark, if the rest is correct	(4)

Q23.

Question Number	Answer	Mark
(i)	<p>The only correct answer is A: It removes electrons from the paint drops</p> <p>B is incorrect because that would give an overall negative charge to the drops</p> <p>C is incorrect because protons are not transferred</p> <p>D is incorrect because protons are not transferred</p>	(1)

Question Number	Answer	Additional Guidance	Mark
(ii)	<p>An explanation linking like charged drops are repelling each other (1)</p> <p>(so) spray is wider (from sprayer Y) (1)</p>	<p>more spread out / finer / larger area / more dispersed</p>	(2)

Question Number	Answer	Additional Guidance	Mark
(iii)	<p>An explanation linking metal (wire) can conduct electrons / charge (from earth) (1)</p> <p>(so) prevent (positive) charge accumulating on object (1)</p>	<p>metal is a conductor</p> <p>discharge (the object)</p>	(2)