

TO TURN ON THE INLET
VALVE BEFORE RUNNING
OUT THE HOSE



VPL SMOOTH

ACUTE

ELEVATORS

TO TURN ON THE INLET
VALVE BEFORE RUNNING
OUT THE HOSE.

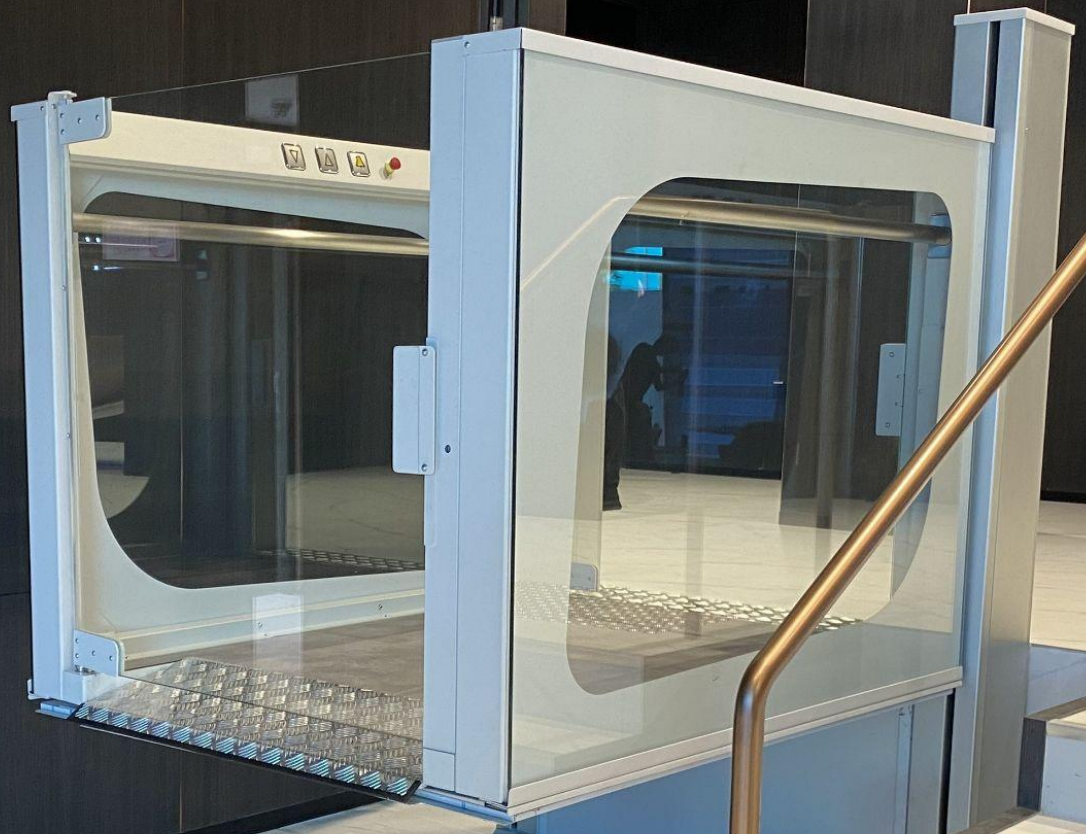





VPL SMOOTH - STEP LIFT

Our economical step lift offers low energy consumption, an array of sizes and quick simple installation. With numerous finishing options to suit all environments our VPL Smooth lift is a great access solution for your residential or commercial space.



SPEED: 0.10 M/S

The Eco home lift delivers a safe, smooth and comfortable user experience travelling between floors. In compliance with the Machinery Directive 200/42/UKCA



PIT & HEADROOM REQUIREMENTS

With no pit requirement and integrated ramp provided. Minimum headroom of only 2000mm from the top floor level..



BELT DRIVE SYSTEM

With no need for external tank or control box we offer the best most energy efficient solution for both the user and the property requirements.



RATED LOAD UP TO 400kg

With a lifting capacity of 400 kg the VPL smooth is suitable for all wheelchair access requirements.



TRAVEL UP TO 3000mm

Our wheelchair lifts can accommodate changes in level from 600mm to 3000mm. In commercial and domestic environments, Suitable for most residential applications, with fast and simple installation.



MEETS ALL LEGISLATION REQUIREMENTS

The Eco home lift complies with all the latest safety standards, type tested and UKCA marked.



INDOOR AND OUTDOOR USE

With its durable and fashionable finishes, this energy-efficient wheelchair platform lift is suitable for both indoor and outdoor use. It is also easy to operate, dependable, simple to maintain, and long-lasting.



WHEELCHAIR ACCESS

The VLP Smooth is especially made for projects where relatively few changes to existing structures are necessary. The lift makes it safe and simple for wheelchair users to enter areas where stairs would otherwise limit their movement.

VPL SMOOTH LIFT DESIGN.

Any building, whether old or modern, will blend in thanks to the lifts exclusive design, like LED Lighting, finishing options, and glass constructions. In addition, there are over 100 alternative configurations for the lift, as well as a variety of non-standard custom finishes.

- MODERN LIGHTWEIGHT DESIGN
- ROBUST DURABLE CONSTRUCTION
 - LOW SPACE REQUIREMENTS
 - HIGH LEVEL OF SECURITY
 - SIMPLE TO USE
 - NO PIT REQUIRED
- SIMPLE TO INSTALL AND EASY TO SERVICE
- OVERALL LOW MAINTENANCE AND RUNNING COSTS

Our VPL Smooth step lift is low-maintenance and dependable, the seamless start and stop performance ensure that travelling is a pleasant experience. The lift will turn off automatically after some time if it is not being used to reduce energy costs..

Our step lift may be used by persons of all physical capacities thanks to the latest touch-sensitive controls.

FUNCTIONAL IN ANY PUBLIC ENVIRONMENT

The ideal solution to overcome architectural barriers in public environments. It will ensure easy access for everyone in schools, shops, restaurants and offices.

LED lighting, improves the design of the product and helps to visualise its overall dimensions in the dark ensuring higher safety.



TECHNICAL SPECIFICATIONS

Travel	Max 3000 mm Min 600 mm
Load	400kg
Stops	2 Max
Entrances	Front & Rear
Controls	Hold to run
Platform Dimensions	1100 x 1400 mm 900 x 1400 mm 900 x 1250 mm
Pit Depth	Not required, integrated ramp, floor height 70mm
Drive	Electromechanical motor with belt
Max speed	0.10 m/sec
Cycles per hour	10 max
Temperature range	-5°C / +40°C
Noise	Less than 30 dB
Power Supply	Single Phase 230 Vac - 50-60 Hz - 16A
Installed power	1.1 kW
Reference standard	UKCA mark - in compliance to BS 6440-2011 and D.M. 2006/42/UKCA



Dimensions

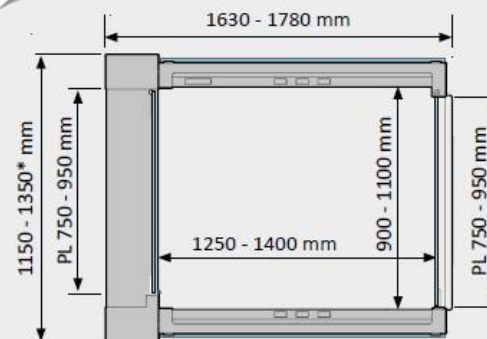

* Allow at least 400 mm of free space on both sides for maintenance

Safeties

- ⊠ Anti-crushing sensitive bottom under the platform
- ⊠ Front side anti-shearing wall
- ⊠ Safety gear
- ⊠ Overload and belt loosening sensor
- ⊠ Electric lock locking control
- ⊠ Automatic emergency descent operated on board with UPS system in case of power outage
- ⊠ STOP button for emergency stop
- ⊠ Acoustic ALARM button on board
- ⊠ Emergency light
- ⊠ Disabling key ON / OFF at upper level
- ⊠ Autodialler (optional)
- ⊠ Motion buzzer (optional)



INSTALLATION

Installation is unintrusive and simple due to the little amount of required building work, the need for only a small pit, and the extremely low headroom requirements. In order to ensure that you can go about your normal business, we aim to complete the installation quickly and with the least possible disruption to your property or the neighbourhood.

QUICK AND EASY TO INSTALL

- The VPL Smooth can be installed in a short time: less than one day.
- The main components are pre-assembled supplied to simplify and speed up the installation process.
- The possibility of adjusting the travel +/- 50mm on site avoids small and annoying steps that you can find between the platforms and the finished floor.

NATIONWIDE INSTALLATIONS

We have been installing wheelchair access lifts of the highest quality to residential and commercial properties across the UK for decades. we take a personal approach to each project and ensure that all your requirements and ideas are reflected in the finished project with a swift and hassle free installation. Always following the UK's strictest quality and safety standards.





SERVICING & WARRANTY

Acute Elevators always include a full comprehensive 12 months warranty with every new lift installation, comprising of cover for all of the parts and 2 service visits annually as standard.

BOOK A CONSULTATION

Contact Acute today, we will evaluate your needs and desires, discuss the available options and start designing the perfect lift package solution.



0203 410 0495 - LONDON

0161 523 6299 - MANCHESTER



info@acute-elevators.co.uk



www.acute-elevators.co.uk





FINISHES



RAL 9010	RAL 1013	DESERT ROSE	RAL 7035	RAL 7001
RAL 9006	RAL 9007	GREY MICA	BLASTED COPPER	ANTIQUE RUST
RAL 8019	RAL 7016	RAL 9005	BRONZE	GOLD

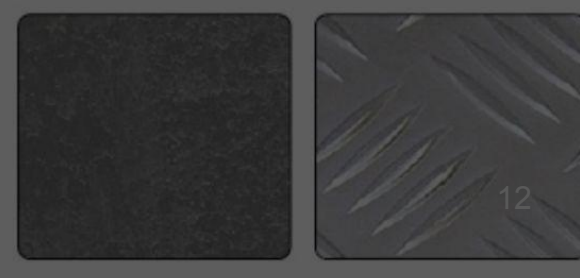





AVAILABLE FINISHES.

We provide robust powder coat finishes for the lift frames and guide covers and choice of flooring. They have hygienic, easy-to-clean matte and glossy surfaces. They offer a premium appearance.

FINISHES

LIFT GUIDES & GUIDE INFILL



ANODIZED ALUMINIUM

PLATFORM PAINTING



RAL 7035 - LIGHT GREY (STD)

GLASS OPTIONS



TRANSPARENT (STD)

SMOKE GREY (OPTIONAL)

FLOORING MATERIAL



2810 - CEMENT MULTI-LAYER LAMINATE



ALUMINIUM 5 BAR TREAD PLATE

RAL CHOICES - OPTIONAL FOR PLATFORM AND / OR GUIDE INFILL PANEL



CONTROL BUTTONS

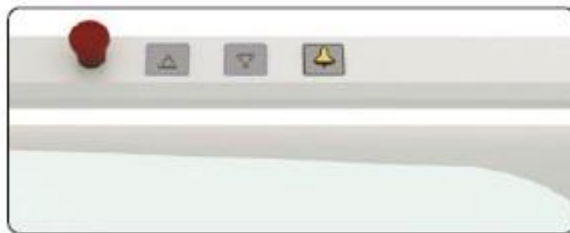

PLATFORM OPERATING PANEL (COP)



PUSH BUTTON

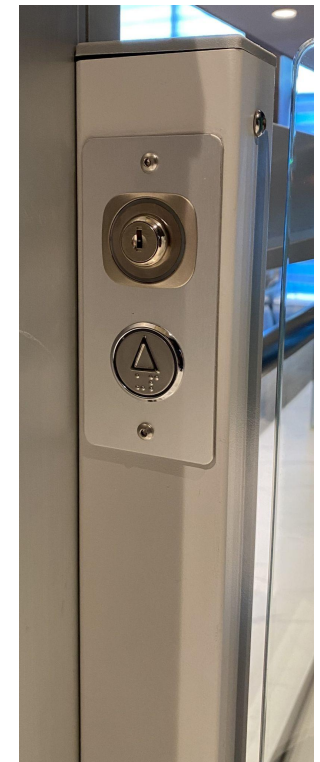

LANDING CALL STATION



PLATFORM WALLS, GATES & GUIDE PANEL FINISHES

POWDER COATING

The environmental choice, due to the fact that almost no pollutants are emitted into the air. Available on practically every available surface of the lift, we offer electric powder coating when a more specialised finish is required. Our powder coated surfaces are particularly durable since they can be more resistant to chipping, scratching, fading, and wearing than other finishes.







ACUTE

ELEVATORS

Contact:

www.acute-elevators.co.uk

info@acute-elevators.co.uk

0203 410 0495 - London

0161 523 6299 - Manchester

Unit B1, Black Barns, Upper Nashenden Farm

Stoney Lane, Off Maidstone Road

Rochester, Kent, ME1 3QJ