



Ultra Smart Antenna

Hardware Version 5.1.0



NOTICE

This document contains the technical specifications and operating instructions for the Ultra and Ultra+ Smart Antennas. Please review it carefully before using the device.

Nordian is committed to providing state-of-the-art products to our customers.

DISCLAIMER

This document and all information contained herein are the property of Nordian Inc. Reproduction of this document as a whole or in part is prohibited.

As this document is continuously updated, its contents may change without prior notice. Please ensure that you are always referring to the latest version.

This document is intended to present the general installation and application guide for Ultra Smart Antennas usage. For detailed information on the device configuration, please refer to the Interface Manual.

Visit www.nordian.com for more information.

CONTACT INFORMATION

Website: www.nordian.com

Customer Support: support@nordian.com

Version Log

Date	Version	Updates
08/2023	HW 4.0.1	First public HW 4.0.0 version.
02/2024	HW 4.0.2	Added Ultra+ and new commands.
07/2024	HW 4.0.3	Specifications update
10/2024	HW 4.0.4	Manual UX update
01/2025	HW 4.0.5	Added new specs and features
08/2025	HW 5.0.0	New Hardware Core Version
10/2025	HW 5.0.1	Update of LEDs Status Table

TABLE OF CONTENTS

1. Introduction	1
1.1. Ultra Smart Antenna Overview	1
1.2. Applications	2
2. Technical Specifications	3
2.1. Electrical	3
2.2. Accuracy	3
2.3. GNSS Specifications	3
2.4. IMU Sensor	4
2.5. Mechanical	4
2.6. Connector pinout	6
2.6.1. Mating connector pinout	7
3. Ultra Smart Antenna Installation	7
3.1. Engineering Harness	7
3.2. Mechanical Installation	8
3.2.1. Ultra Smart Antenna Mounting Bracket	9
3.2.2. RTK RF Antenna Mounting Bracket - Mechanical Details (Ultra+ only)	11
3.2.3. Mounting Orientation	13
3.2.4. Inclination	14
3.2.5. Height	15
3.2.6. Terrain Compensation	15
3.2.7. Radio Configuration (Ultra+ only)	16
3.3. Communication	17
3.3.1. Serial RS-232	17
3.3.2. CAN	17
3.3.3. Ground Speed Output	18
3.3.4. PPS	18
4. Operation	19
4.1. NMEA 0183 (Serial Port)	19
4.2. NMEA 2000 (CAN FD Port)	19
4.3. Diagnostics	20
5. General	23
5.1. Default configuration	23
5.2. Product Variants	27
5.3. Warranty	28
5.4. Support	28
6. Firmware Update	29
6.1. Nordian Application Software	29
6.2. Firmware Update	30

FIGURES

Figure 1: Ultra Smart Antenna Dimensions Top View (mm)	4
Figure 2: Ultra Smart Antenna Dimensions Rear View (mm)	5
Figure 3: Ultra+ Smart Antenna Dimensions Rear View (mm)	5
Figure 4: Ultra Smart Antenna Bottom View (mm)	5
Figure 5: Device Connector Detail	6
Figure 6: Mating Connector Rear view	7
Figure 7: Connection Example	7
Figure 8: Mechanical Fixation	9
Figure 9: Smart Antenna Mounting Bracket Option 1 - Top View	10
Figure 10: Smart Antenna Mounting Bracket Option 1 - Side View	10
Figure 11: Smart Antenna Mounting Bracket Option 2 - Top View	10
Figure 12: Smart Antenna Mounting Bracket Option 2 - Side View	11
Figure 13: Ultra+ Antenna Support Dimensions (millimeters)	11
Figure 14: Ultra+ Antenna Dimensions (centimeters)	13
Figure 15: Ultra Smart Antenna Orientation	13
Figure 16: Ultra Smart Antenna Badly Oriented	14
Figure 17: Ultra Smart Antenna Inclined Due to Roof Tilt	14
Figure 18: Ultra Smart Antenna Inclined Due to Roof Camber	15
Figure 19: Terrain Compensation - Pitch Position Compensation	16
Figure 20: Terrain Compensation - Roll Position Compensation	16
Figure 21: Ultra Smart Antenna Status LEDs Indicator	21
Figure 22: Nordian Application Interface	29
Figure 23: Nordian Application Connection	31
Figure 24: Firmware Update Screen	31
Figure 25: Firmware Update Successful	32

TABLES

Table 1: Electrical Requirements	3
Table 2: Ultra Smart Antenna Accuracy	3
Table 3: Receiver Supported Signals	3
Table 4: Convergence Time and Acquisition*	4
Table 5: Connector Pinout Description	6
Table 6: Suggested Harness Pinout	8
Table 7: Optimal Antenna Length	12
Table 8: NMEA 0183 Available Messages	19
Table 9: NMEA 2000 Available Messages	19
Table 10: J1939 Available Messages	20
Table 11: Status LEDs Behavior	21
Table 12: Communications Default Configurations	23
Table 13: GNSS Receiver Default Configuration	23
Table 14: NMEA 0183 Default Configuration	23
Table 15: NMEA 2000 Default Configuration	25
Table 16: J1939 Default Configuration	25
Table 17: IO Default Configuration	25
Table 18: Radio Default Configuration (Ultra+ Only)	26
Table 19: Speed Filter Default Configuration	26
Table 20: Course Over Ground (Heading) Default Configuration	26
Table 21: Ultra Smart Antennas Variants	27

1. Introduction

1.1. Ultra Smart Antenna Overview

Ultra Smart Antenna is a cutting-edge navigation solution engineered for unmatched accuracy and reliability. Purpose-built for fast integration and effortless configuration, it offers seamless compatibility across multiple platforms. Ultra combines wide satellite band connectivity, an advanced IMU-based correction system, correction services and two-way satellite communication to deliver precise position, velocity, altitude, and timing – while enabling continuous data exchange for smarter, more connected operations.

Main Features:

- Full GNSS compatibility: GPS, GLONASS, BeiDou, Galileo, NavIC, QZSS, SBAS (including WAAS, EGNOS, GAGAN, MSAS, BDSBAS) and all-band L1, L2, L5 and L6.
- GNSS Signal Compatibility:
 - GPS: L1C/A, L2C, L5
 - GLONASS: L1OF, L2OF
 - Galileo: E1B/C, E5a, E6
 - BeiDou: B1I, B1C, B2a, B3I
 - QZSS: L1C/A, L1C/B, L2C, L5
 - SBAS: WAAS, EGNOS, GAGAN, MSAS, BDSBAS
- Maximum Update Rate:
 - GNSS: 25 Hz
 - GNSS + IMU Sensor Fusion: 50 Hz
- Initialization Times
 - Cold start: 24s; Aided start: 2s; Reacquisition: 2s;
- Embedded high-grade IMU:
 - 6-axis;
 - Accelerometer full-range 16 g;
 - Gyroscope full-range 2 kdps;

- GNSS+IMU sensor fusion;
- Reduced start-stop delays;
- Anti-interference and scintillation algorithms;
- Terrain compensation;
- User Interfaces
 - Three (3) Serial UART COM ports are available, except for the Ultra+ model, which supports only two ports (COM1 and COM2);
 - One (1) CAN port;
 - Pulse Per Second (PPS) output;
 - Ground Speed Output (GSO/Radar) output;
 - Two (2) status LED indicators;
- Base and Rover features with RTK corrections
- Connectivity:
 - Cellular 5G/4G fallback;
 - NTN 2-way Satellite Communication

1.2. Applications

Ultra Smart Antenna is engineered for versatility, delivering reliable high-precision navigation across a wide range of industries – with agriculture as a key area of application.

Designed for seamless integration, the Ultra Smart Antenna supports multiple platforms and interfaces, enabling smooth deployment with both modern systems and legacy equipment already in operation. With configurable update rates and broad connectivity options, it enhances performance and interoperability wherever precise positioning and communication are required.

2. Technical Specifications

2.1. Electrical

Please see below the specified working voltage range. Applying voltage outside the specified range may result in permanent device damage.

Table 1: Electrical Requirements

Specification	Value
Voltage	+7 to +32 VDC
Average Current	500 mA @12 V
Average Power	6 W
Peak Current	800 mA @ 12 V

2.2. Accuracy

Table 2: Ultra Smart Antenna Accuracy

Accuracy	Standalone	P1 Soft-Intelligence	P2 Soft-Intelligence
Horizontal Accuracy (RMS)*	1.2 m	0.40 m	0.03 m
Pass-to-Pass Accuracy	0.20 m	0.10 m	0.02 m

**Horizontal accuracy may vary based on satellites in view, clear sky and multipath*

2.3. GNSS Specifications

Table 3: Receiver Supported Signals

Constellation	Frequency
GPS	L1C/A, L2C, L5
GLO	L10F, L20F
GAL	E1B/C, E5a, E6
BDS	B1I, B1C, B2a, B3I
QZSS	L1C/A, L1C/B, L2C, L5
SBAS	WAAS, EGNOS, GAGAN, MSAS, BDSBAS

Table 4: Convergence Time and Acquisition*

Time and Acquisition	
Convergence Time	< 40 s
Acquisition: Cold start	25 s
Acquisition: Aided start	2 s
Reacquisition	2 s

*Time may vary significantly based on satellites in view, clear sky and multipath.

2.4. IMU Sensor

A high-end industrial Inertial Measurement Unit (IMU) is an integral part of the product’s positioning. The IMU operates continuously alongside the GNSS system. Embedded IMU has the following characteristics:

- 6-axes
- Accelerometer full range: $\pm 16g$
- Gyroscope full range: ± 2000 degrees per second

2.5. Mechanical

This section presents the general mechanical characteristics and specifications.

Figure 1: Ultra Smart Antenna Dimensions Top View (mm)

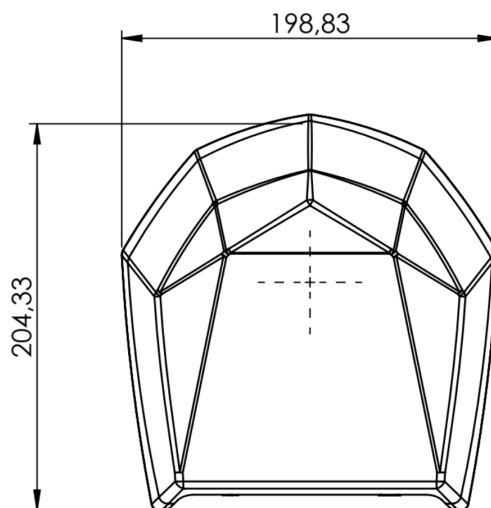

Figure 2: Ultra Smart Antenna Dimensions Rear View (mm)

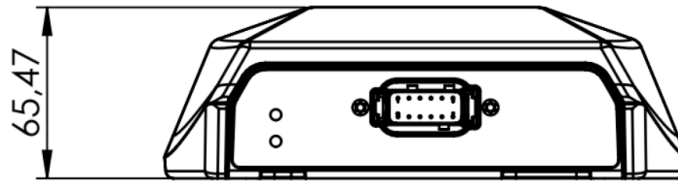
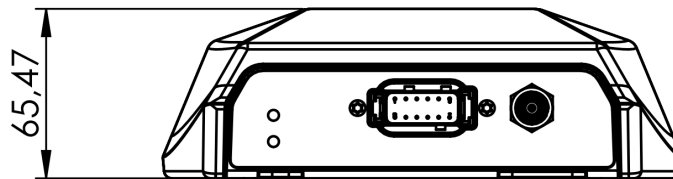
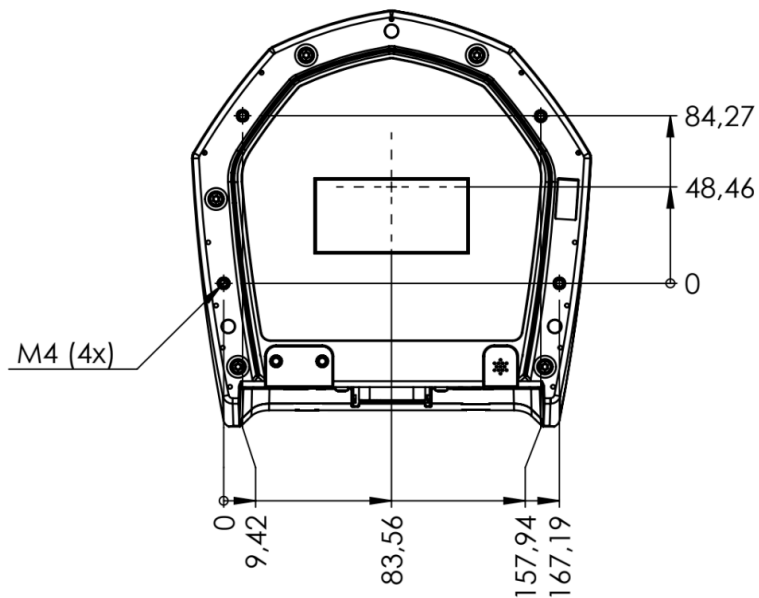

Figure 3: Ultra+ Smart Antenna Dimensions Rear View (mm)



Note: The Ultra+ and the Ultra Smart Antenna have identical dimensions. The sole difference is the inclusion of the external RF antenna and its support, as specified in Section 3.2.2.

Figure 4: Ultra Smart Antenna Bottom View (mm)



2.6. Connector pinout

The Ultra Smart Antenna board can be connected through the DTM13-12 connector (Part Number: DTM13-12PA).

Figure 5: Device Connector Detail

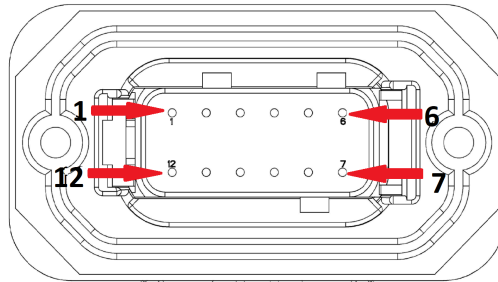

Table 5: Connector Pinout Description

PIN	Abbreviation	Function
1	CAN High	CAN communication high output
2	COM 1 Tx	Serial 1 RS-232 output
3	COM 1 Rx	Serial 1 RS-232 input
4	PPS	Pulse per Second output
5	GSO	Ground Speed Output
6	COM 3 Rx	Serial 3 RS-232 input
7	COM 3 Tx	Serial 3 RS-232 output
8	COM 2 Rx	Serial 2 RS-232 input
9	COM 2 Tx	Serial 2 RS-232 output
10	+VBAT	Positive power source connection (VCC)
11	GND	Ground voltage connection
12	CAN Low	CAN communication low output

2.6.1. Mating connector pinout

The mating connection shall be made using the DTM06-12 connector:

- Part number: DTM06-12SA.
- Pinout: identical to Table 5.

Figure 6: Mating Connector Rear view

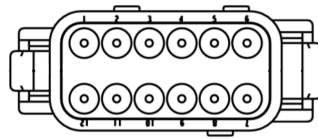

3. Ultra Smart Antenna Installation

3.1. Engineering Harness

An example of the Ultra Smart Antenna connection is shown in Figure 7:

Figure 7: Connection Example

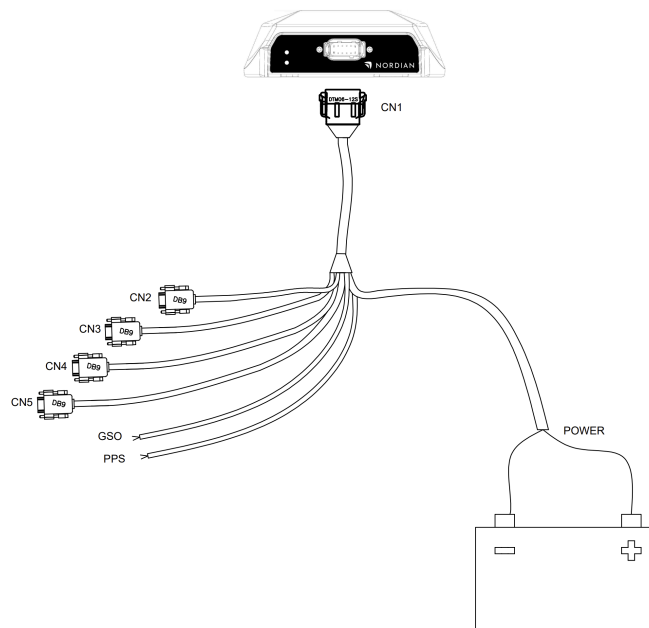

To build the engineering harness, please follow the pinout shown in Table 5. Make sure the power supply meets the requirements in Section 2.2. For device configuration, you can use connectors CN2, CN3, and CN4 (labeled Serial 1, Serial 2, and Serial 3), by connecting them to an external serial terminal. More details are provided in Section 4.5.

Table 6: Suggested Harness Pinout

CN1	CN2	CN3	CN4	CN5	GSO	PPS	POWER	FUNCTION
1	-	-	-	7	-	-	-	CAN High
2	2	-	-	-	-	-	-	COM 1 Tx
3	3	-	-	-	-	-	-	COM 1 Rx
4	-	-	-	-	-	X	-	PPS
5	-	-	-	-	X	-	-	GSO
6	-	-	3	-	-	-	-	COM 3 Rx
7	-	-	2	-	-	-	-	COM 3 Tx
8	-	3	-	-	-	-	-	COM 2 Rx
9	-	2	-	-	-	-	-	COM 2 Tx
10	-	-	-	-	-	-	X	+VBAT
11	5	5	5	-	X	X	X	GND
12	-	-	-	2	-	-	-	CAN Low
DTM06-12S	DB9	DB9	DB9	DB9	**	**	**	CONNECTOR

3.2. Mechanical Installation

The Ultra Smart Antenna must be installed in accordance with the specifications in this section. While the device may be mounted in any location that best suits the vehicle, installations that do not follow these recommendations can reduce performance.

For optimal operation, the antenna should be mounted on the top of the vehicle, at the highest point, with an unobstructed view of the sky in all directions. The mounting should be as secure as possible;

any vibration caused by poor fixation must be eliminated, even if this results in slightly reduced positioning accuracy.

Ultra Smart Antenna supports four (4) fixation methods:

1. Magnets: three internal magnets for fixation on metallic vehicle roofs.
2. Nordian Support: Nordian metallic support connects in the three highlighted pins, please refer to Section 3.2.1 for more information.
3. Screw holes: four (4) fixation holes with M4 screw thread.
4. Antenna Support: two (2) fixation holes for the antenna support (only used for Ultra+).

Figure 8: Mechanical Fixation

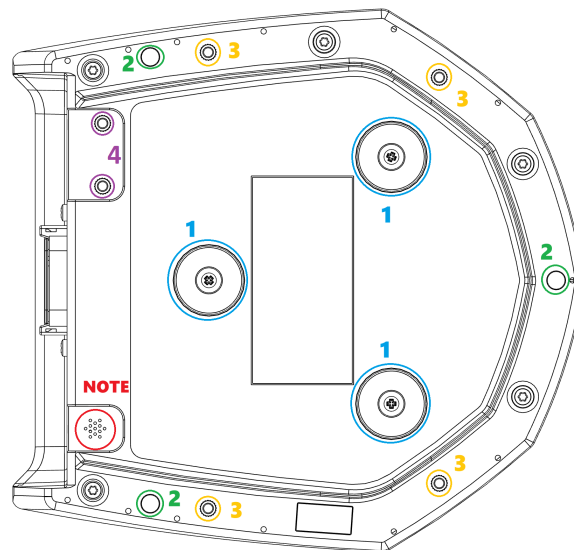

NOTE: The air vent must remain unobstructed at all times. Ensure adequate clearance to allow proper heat exchange with the atmosphere.

3.2.1. Ultra Smart Antenna Mounting Bracket

To simplify installation, Nordian Inc. offers two sheet-metal bases designed for the Ultra Smart Antenna. Their physical dimensions are shown in Figures 9–12. Depending on the application, these bases provide a convenient and reliable mechanical fixation option. Please reach out to our sales team if you need assistance.

Figure 9: Smart Antenna Mounting Bracket Option 1 - Top View

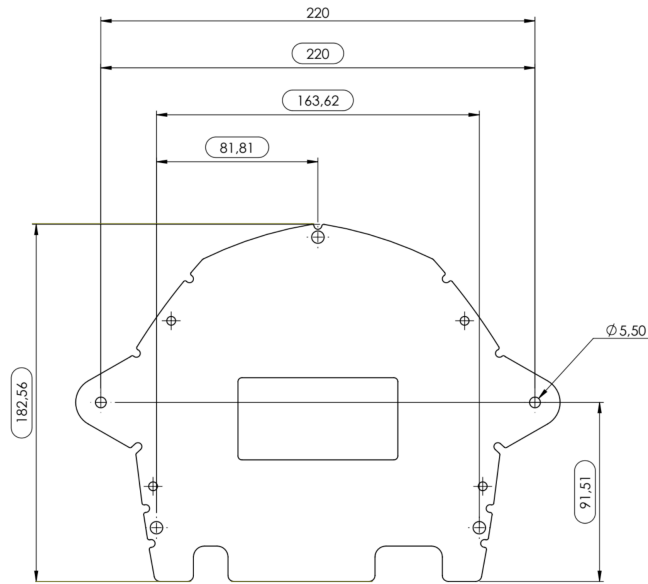

Figure 10: Smart Antenna Mounting Bracket Option 1 - Side View

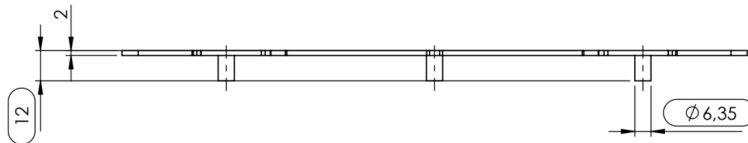

Figure 11: Smart Antenna Mounting Bracket Option 2 - Top View

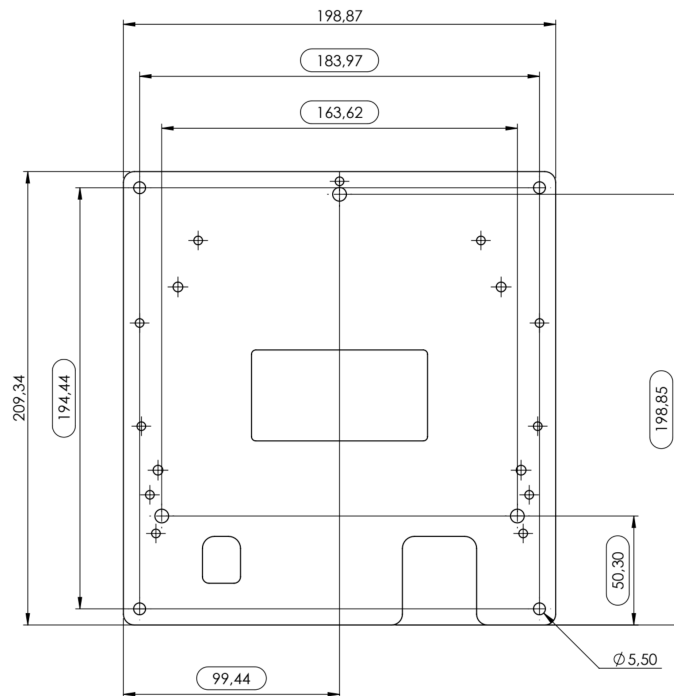
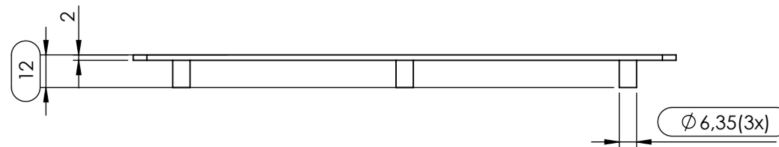

Figure 12: Smart Antenna Mounting Bracket Option 2 - Side View



Both sheets are easy and reliable fixation methods specially designed for Ultra Smart Antenna. Choose the one which best suits your application case.

3.2.2. RTK RF Antenna Mounting Bracket - Mechanical Details (Ultra+ only)

Ultra+ can receive its correction service via radio frequency and therefore requires an antenna. The device is provided with a UHF antenna (360–520 MHz) and its mechanical support. The support must be mounted on the rear of the device using the screw holes specified in Section 3.2. The antenna is then attached to the support and connected to Ultra+ using the included cable.

Figure 13: Ultra+ Antenna Support Dimensions (millimeters)

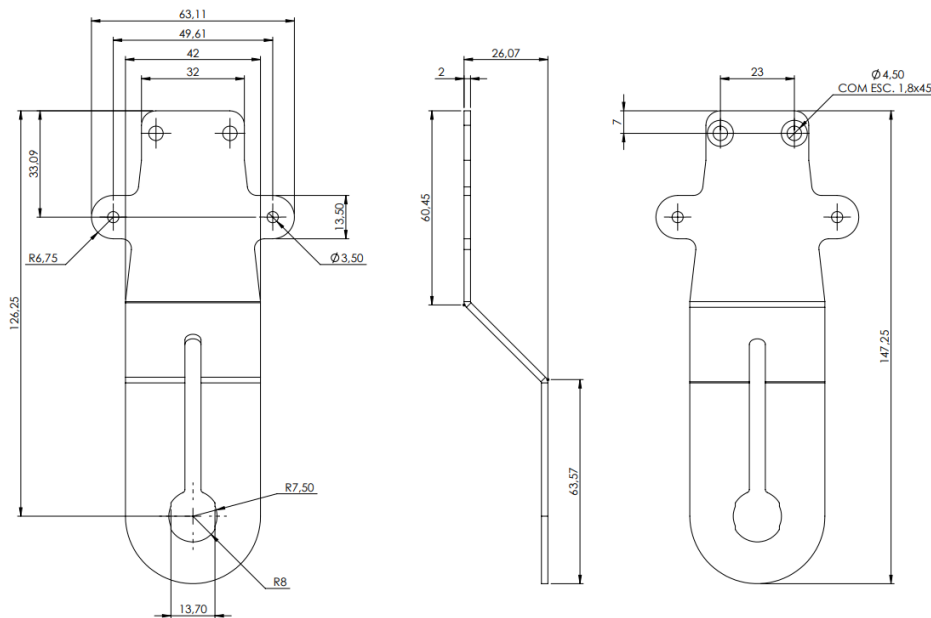

The RTK kit includes a 10 cm coaxial cable to connect the antenna to the Ultra+ case. The antenna features an NMO connector, while the TNC male connector on the cable must be securely attached to the TNC female connector located at the rear of the Ultra Smart Antenna unit.

In order to achieve optimal performance it's recommended to cut the antenna length according to the RTK Radio frequency setup. Table 7 shows the length the antenna should have based on the operating frequency. The antenna rod must be removed from the base coil and the length must be considered from top to bottom.

Table 7: Optimal Antenna Length

Frequency (MHz)	Length (cm)
360	42
370	40
380	38
390	37
400	35
410	34
420	33
430	31
440	29
450	28
460	27
470	26
480	25
500	24
510	23
520	21

NOTE: In all lengths above it must be considered the length of the slotted rod on the support coil, add 2,5 cm to all lengths.

Figure 14 shows the antenna dimensions before the length adjustment.

Figure 14: Ultra+ Antenna Dimensions (centimeters)

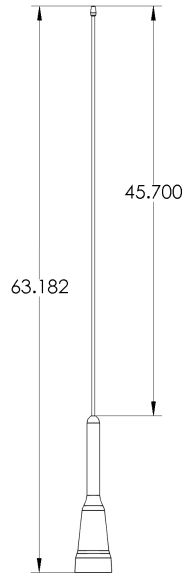

3.2.3. Mounting Orientation

The Ultra Smart Antenna's internal correction algorithms combine GNSS and IMU data. For optimal accuracy, the antenna must be oriented toward the front of the vehicle. Since the IMU compensates for acceleration along all axes, correct device orientation is essential.

Figure 15: Ultra Smart Antenna Orientation

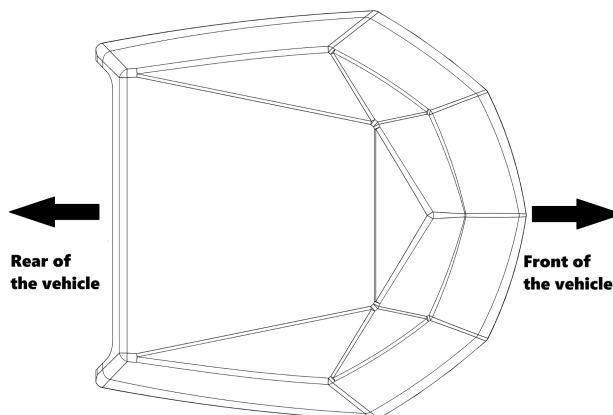

Any misalignment may result in decreased accuracy and position offset. Figure 16 shows the vehicle's correct orientation (green) and a Smart Antenna badly oriented (red). Ultra Smart Antenna orientation must be parallel to the vehicle orientation. Ideally both vectors should overlap.

Figure 16: Ultra Smart Antenna Badly Oriented

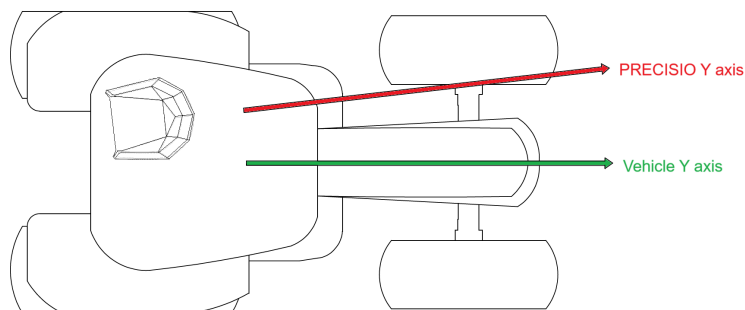

3.2.4. Inclination

Besides horizontal orientation, vertical inclination must also be considered. The two main sources of inclination are roof tilt and roof camber, presented in Figures 17 and 18. Ultra Smart Antenna must be as flat as possible, any inclination may result in position offset and accuracy degradation.

Figure 17: Ultra Smart Antenna Inclined Due to Roof Tilt

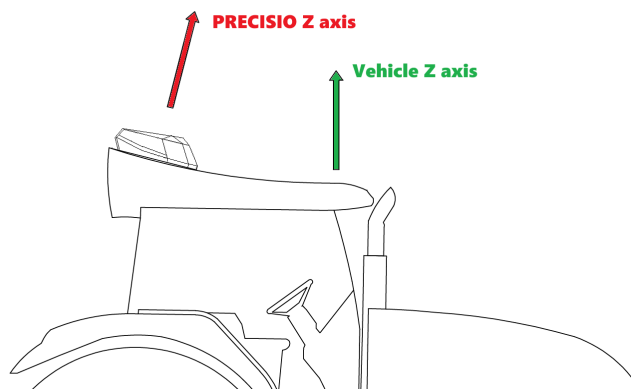
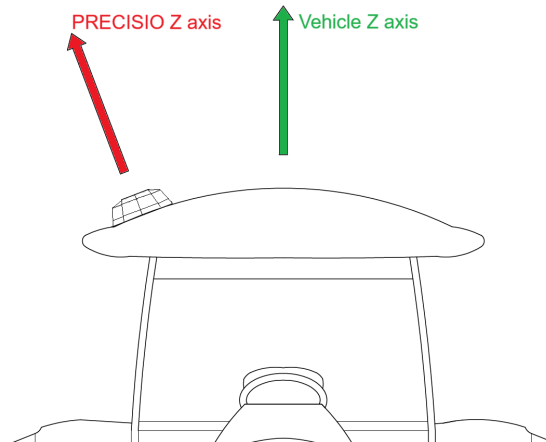

Figure 18: Ultra Smart Antenna Inclined Due to Roof Camber

These two situations can be corrected by placing Ultra Smart Antenna in a more suitable position, such that the correct vector (green) and Ultra Smart Antenna vector (red) overlap.

3.2.5. Height

After installation, the Ultra Smart Antenna must be configured with the correct height from the device to the ground (machine roof height). The default value is 3.5 m. Configuration is performed exclusively via the Terrain Compensation Height Set Command; refer to the Ultra Smart Antenna Product Configuration for details.

3.2.6. Terrain Compensation

The Ultra Smart Antenna incorporates a Terrain Compensation algorithm that enhances performance on uneven terrain. This algorithm reduces errors caused by rocky or rugged surfaces, which could otherwise result in significant accuracy loss. Inclinations and elevation changes on hilly terrain are also considered, ensuring reliable operation in challenging environments. For further details, refer to the Ultra Smart Antenna Product Configuration.

Figure 19: Terrain Compensation - Pitch Position Compensation

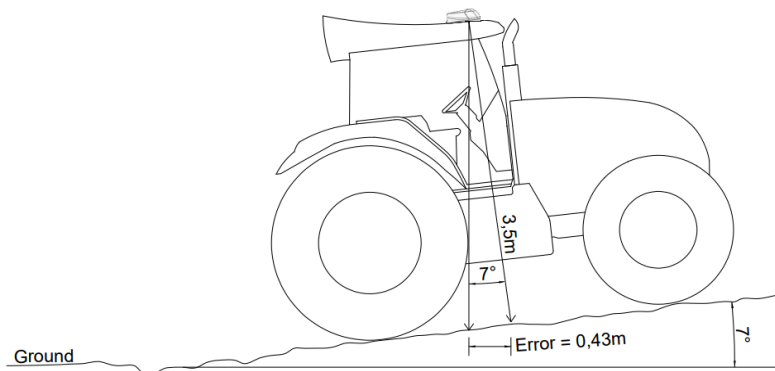
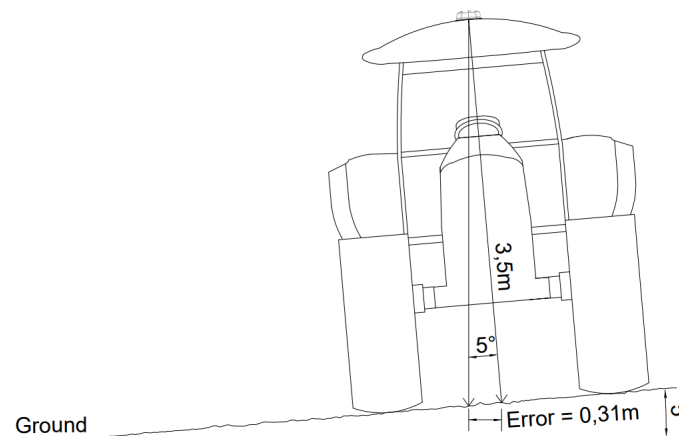

Figure 20: Terrain Compensation - Roll Position Compensation



3.2.7. Radio Configuration (Ultra+ only)

The RTK correction signal is delivered to the Ultra+ via radio frequency. The radio transmitter is installed with the Base Station (for details, contact Nordian Inc.). The supported frequency range is 390–480 MHz, and the following radio protocols are currently available:

- HXON: 6 preset configurations;
- PACIFIC CREST: 24 preset configurations;
- SATEL: 22 preset configurations;
- TRIMBLE: 14 preset configurations.

3.3. Communication

Ultra Smart Antenna has four configurable interface communication options: Serial, CAN, GSO and PPS. Serial communication is available in 3 (three) RS-232 ports and CAN communication is available in one (1) port.

3.3.1. Serial RS-232

Ultra Smart Antenna configuration can be done through serial communication, on either COM 1, COM 2 or COM 3. Each one of the ports can be independently configured.

NOTE: *Ultra+ provides only COM 1 and COM 2. COM 3 is not available.*

- Pinout:
 - COM1: 2 (Tx) and 3 (Rx);
 - COM2: 9 (Tx) and 8 (Rx);
 - COM3: 7 (Tx) and 6 (Rx);
- NMEA0183 protocol messages are sent exclusively via RS-232;
- Available baudrates (kbps): 9600, 19200, 38400, 57600, 115200, 230400, 460800;
- No parity bit / 1 stop bit / 8 data bits / no handshaking;
- For messages configuration please refer to the *Ultra Smart Antenna Interface Manual*.

3.3.2. CAN

One (1) Controller Area Network bus (CAN bus) is available.

- Pinout: 1 (CAN High) and 12 (CAN Low);
- Available bitrates (kbps): 125000, 250000, 500000, 1000000, 2000000;
- CAN bus version: CAN 2.0B - extended;
- Max CAN FD port speed: 8 Mbps;

- Built-in 120Ω parallel resistor;
- NMEA2000 protocol messages are sent exclusively via CAN bus;
- J1939 protocol messages are sent exclusively via CAN bus;
- For messages configuration please refer to the *Ultra Smart Antenna Product Configuration*;

3.3.3. Ground Speed Output

Ground Speed Output (GSO), also known as *Radar*, is an output signal whose frequency varies according to Ultra Smart Antenna's speed with respect to the ground.

When idle the GSO output is stable at GND level. Once the speed has passed the configurable speed threshold GSO output will vary digitally from GND to +VBAT level with frequency proportional to Ultra Smart Antenna's speed. The number of transitions per meter (from the GND to the +VBAT values) can be configured.

- Configuration regarding GSO must be done through serial communication;
- For configuration please refer to the *Ultra Smart Antenna Interface Manual*.

3.3.4. PPS

Pulse Per Second (PPS), is an output signal that generates pulses synchronized with the satellites internal Ultra Smart Antennan clock. It's a useful tool for Ultra Smart Antennan timing. PPS vary digitally from GND to +VBAT level. The pulse edge is synchronized with the satellites clock, it can be configured for rising or falling edge synchronization. Other than that, the pulse duty cycle and period can be configured.

- All configuration regarding PPS must be done through serial communication.
- For configuration please refer to the *Ultra Smart Antenna Interface Manual*.

4. Operation

4.1. NMEA 0183 (Serial Port)

Protocol compatible with serial communication. NMEA0183 available output messages are shown in the table below:

Table 8: NMEA 0183 Available Messages

Message	Description
DTM	Datum reference information
GGA	Time, position and fix related data
GLL	Latitude, longitude, time of position fix and status
GRS	Manages GNSS signal data, transmission timing, and system/signal IDs.
GSA	GPS DOP and active satellites
GST	UTC time, RMS value of pseudorange residuals and error ellipse
GSV	Satellites in view related data
HDT	Vessel Heading
RMC	Position, velocity and time
VTG	Course over ground and speed over ground related data
ZDA	UTC time related data

4.2. NMEA 2000 (CAN FD Port)

Protocol compatible with CAN bus communication. NMEA2000 available output messages are shown below:

Table 9: NMEA 2000 Available Messages

Message	Description
PGN126992	System Time
PGN127250	Vessel Heading
PGN127251	Rate of Turn
PGN127257	Attitude (pitch, roll, yaw)
PGN128001	Speed (through water)
PGN129025	GNSS position, rapid update

Message	Description
PGN129026	Course over ground and speed over ground, rapid upgrade
PGN129027	Position delta high precision rapid update
PGN129028	Altitude delta, rapid Update
PGN129029	GNSS position data
PGN129539	GNSS dilution of precision
PGN129540	GNSS satellites in view
PGN129542	GNSS Pseudorange Noise Statistics
PGN130312	Temperature
PGN130578	Longitudinal, transverse and stern speed

Table 10: J1939 Available Messages

Message	Description
PGN65254	Time and Date
PGN65256	Vehicle speed and direction
PGN65267	Vehicle position

- For configuration details please refer to the *Ultra Smart Antenna Interface Manual*.

4.3. Diagnostics

Ultra Smart Antenna has two (2) LEDs used for status indication. Each blinking has a corresponding meaning, as exposed on Table 11. This is useful for correct functioning verification and fault understanding.

- LED 01: green
- LED 02: yellow

NOTE: always contact Nordian support if a problem persists - never rely on non Nordian personnel for support.

Figure 21: Ultra Smart Antenna Status LEDs Indicator

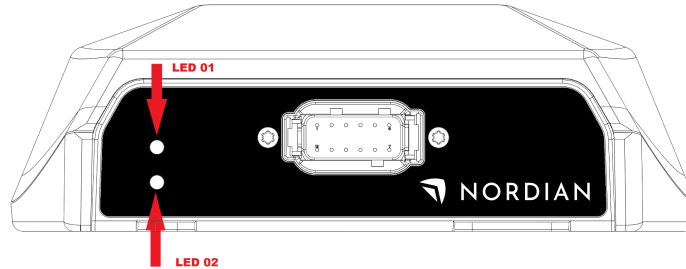

Table 11: Status LEDs Behavior

Category	Device Status	LED 01- Green	LED 02 - Yellow	Description & Recommended Action
Update	Update in Progress	1 blink / 1s pause	Solid ON	Description: The device firmware is currently being updated. Action: Wait for the update process to complete. Do not power off the device.
	Update Error	2 blinks / 1s pause	Solid ON	Description: An error occurred during the update procedure. Action: Retry the firmware update.
	Previous Update Error	3 blinks / 1s pause	Solid ON	Description: An unresolved error from a previous update persists. Action: Retry the firmware update.
Firmware	Firmware Fault	4 blinks / 1s pause	Solid ON	Description: A non-valid firmware image has been detected. Action: Load a valid firmware version onto the device.
	Firmware Rollback	5 blinks / 1s pause	Solid ON	Description: The device has reverted to the last known functional firmware. Action: A firmware update is recommended to restore full functionality.

Category	Device Status	LED 01- Green	LED 02 - Yellow	Description & Recommended Action
Hardware	Power Fault	LEDs blink synchronously at a slow rate (0.5s ON / 0.5s OFF)		<p>Description: The supplied power is outside the acceptable voltage or current margins.</p> <p>Action: Verify the power source. If the fault persists, contact support.</p>
	Hardware Fault	LEDs blink synchronously at a fast rate (0.25s ON / 0.25s OFF)		<p>Description: A hardware malfunction has been detected.</p> <p>Action: Contact technical support.</p>
	Inactive State	LEDs blink alternately. (0.5s ON/OFF, out of phase)		<p>Description: The device is in a standby or inactive mode.</p> <p>Action: Activate the device via the control dashboard or by sending the appropriate serial command.</p>
Operation	Tracking Satellites	Both LEDs are solid ON.		<p>Description: The device is operational and acquiring a satellite fix.</p> <p>Action: Stand by. A position fix should be achieved shortly.</p>
	Position Fixed	Solid ON	Slow blink (1s ON / 1s OFF)	<p>Description: A standard GNSS position fix has been successfully converged.</p> <p>Action: The device is ready for standard operation.</p>
	RTK Fixed	Solid ON	Fast blink (0.25s ON / 0.25s OFF)	<p>Description: The device is successfully receiving correction data and has achieved an RTK fixed solution.</p> <p>Action: High-precision positioning is active.</p>
	Dead Reckoning	Solid ON	Double Fast Blink + Pause (2 × 150 ms ON / 150 ms OFF, followed by 0.5s OFF)	<p>Description: The device is operating in Dead Reckoning mode.</p> <p>No action required. GNSS positioning will automatically recover when the signal improves.</p>

5. General

5.1. Default configuration

Table 12: Communications Default Configurations

Configuration	Default	Unit
\$COM SERIAL1 BAUDRATE _	115200	kbps
\$COM SERIAL2 BAUDRATE _	115200	kbps
\$COM SERIAL3 BAUDRATE _	115200	kbps
\$COM FDCAN1 BITRATE _	500	kbps

Table 13: GNSS Receiver Default Configuration

Configuration	Default (command)	Default (value 1)	Unit
\$GNSS CONSTELLATIONS _ GPS	ENABLED	-	-
\$GNSS CONSTELLATIONS _ GALILEO	ENABLED	-	-
\$GNSS CONSTELLATIONS _ BEIDOU	ENABLED	-	-
\$GNSS CONSTELLATIONS _ GLONASS	ENABLED	-	-
\$GNSS ELEVATION SET _	-	20	deg.
\$GNSS TALKER_ID SET _	-	GN	-
\$GNSS CNO_SET	-	20	dBHz

Table 14: NMEA 0183 Default Configuration

Configuration	Default Status (command)	Default Period (value 2)	Unit	
COM1	\$NMEA0183 SERIAL1 _ DTM _	DISABLED	50	ms
	\$NMEA0183 SERIAL1 _ GGA _	ENABLED	50	ms
	\$NMEA0183 SERIAL1 _ GLL _	DISABLED	50	ms
	\$NMEA0183 SERIAL1 _ GRS _	DISABLED	50	ms
	\$NMEA0183 SERIAL1 _ GSA _	DISABLED	50	ms

	Configuration	Default Status (command)	Default Period (value 2)	Unit
	\$NMEA0183 SERIAL1 _ GST _	DISABLED	50	ms
	\$NMEA0183 SERIAL1 _ GSV _	DISABLED	50	ms
	\$NMEA0183 SERIAL1 _ HDT _	DISABLED	50	ms
	\$NMEA0183 SERIAL1 _ RMC _	DISABLED	50	ms
	\$NMEA0183 SERIAL1 _ VTG _	ENABLED	50	ms
	\$NMEA0183 SERIAL1 _ ZDA _	DISABLED	50	ms
COM2	\$NMEA0183 SERIAL2 _ DTM _	DISABLED	50	ms
	\$NMEA0183 SERIAL2 _ GGA _	DISABLED	50	ms
	\$NMEA0183 SERIAL2 _ GLL _	DISABLED	50	ms
	\$NMEA0183 SERIAL2 _ GRS _	DISABLED	50	ms
	\$NMEA0183 SERIAL2 _ GSA _	DISABLED	50	ms
	\$NMEA0183 SERIAL2 _ GST _	DISABLED	50	ms
	\$NMEA0183 SERIAL2 _ GSV _	DISABLED	50	ms
	\$NMEA0183 SERIAL2 _ HDT _	DISABLED	50	ms
	\$NMEA0183 SERIAL2 _ RMC _	DISABLED	50	ms
	\$NMEA0183 SERIAL2 _ VTG _	DISABLED	50	ms
\$NMEA0183 SERIAL2 _ ZDA _	DISABLED	50	ms	
COM3	\$NMEA0183 SERIAL3 _ DTM _	DISABLED	50	ms
	\$NMEA0183 SERIAL3 _ GGA _	DISABLED	50	ms
	\$NMEA0183 SERIAL3 _ GLL _	DISABLED	50	ms
	\$NMEA0183 SERIAL3 _ GRS _	DISABLED	50	ms
	\$NMEA0183 SERIAL3 _ GSA _	DISABLED	50	ms
	\$NMEA0183 SERIAL3 _ GST _	DISABLED	50	ms
	\$NMEA0183 SERIAL3 _ GSV _	DISABLED	50	ms
	\$NMEA0183 SERIAL3 _ HDT _	DISABLED	50	ms
	\$NMEA0183 SERIAL3 _ RMC _	DISABLED	50	ms
	\$NMEA0183 SERIAL3 _ VTG _	DISABLED	50	ms
\$NMEA0183 SERIAL3 _ ZDA _	DISABLED	50	ms	

NOTE: COM3 configuration is not applicable for Ultra+.

Table 15: NMEA 2000 Default Configuration

Configuration	Default Status (command)	Default Period (value 2)	Unit
\$NMEA2000 FDCAN1 _ PGN126992 _	DISABLED	50	ms
\$NMEA2000 FDCAN1 _ PGN127250 _	DISABLED	50	ms
\$NMEA2000 FDCAN1 _ PGN127251 _	DISABLED	100	ms
\$NMEA2000 FDCAN1 _ PGN127257 _	DISABLED	50	ms
\$NMEA2000 FDCAN1 _ PGN128001 _	DISABLED	100	ms
\$NMEA2000 FDCAN1 _ PGN129025 _	DISABLED	50	ms
\$NMEA2000 FDCAN1 _ PGN129026 _	ENABLED	50	ms
\$NMEA2000 FDCAN1 _ PGN129027 _	DISABLED	50	ms
\$NMEA2000 FDCAN1 _ PGN129028 _	DISABLED	50	ms
\$NMEA2000 FDCAN1 _ PGN129029 _	ENABLED	50	ms
\$NMEA2000 FDCAN1 _ PGN129539 _	DISABLED	50	ms
\$NMEA2000 FDCAN1 _ PGN129540 _	DISABLED	1000	ms
\$NMEA2000 FDCAN1 _ PGN129542 _	DISABLED	50	ms
\$NMEA2000 FDCAN1 _ PGN130312 _	DISABLED	2000	ms
\$NMEA2000 FDCAN1 _ PGN130578 _	DISABLED	250	ms

Table 16: J1939 Default Configuration

Configuration	Default Status (command)	Default Period (value 2)	Unit
\$J1939 FDCAN1 _ PGN65254 _	DISABLED	100	ms
\$J1939 FDCAN1 _ PGN65256 _	DISABLED	100	ms
\$J1939 FDCAN1 _ PGN65267 _	DISABLED	100	ms

Table 17: IO Default Configuration

	Configuration	Default Status (command)	Default (value 1)	Unit
GSO	\$IO GSO _	ENABLED	-	-
	\$IO GSO UPDATE_RATE _	-	10	Hz
	\$IO GSO PPM _	-	60	-
	\$IO GSO MIN_VEL _	-	140	mm/s
PPS	\$IO PPS _	ENABLED	-	-

Configuration	Default Status (command)	Default (value 1)	Unit
\$IO PPS POLARITY _	-	RISING	-
\$IO PPS DUTY_CYCLE _	-	10	%
\$IO PPS _ PERIOD_MS	-	1000	ms

Table 18: Radio Default Configuration (Ultra+ Only)

Configuration	Default (command)	Default Preset (value 1)	Unit
\$RADIO PROTOCOL _ _	HARXON	1	-
\$RADIO PARAM CH_FREQ _	-	390000000	Hz

Table 19: Speed Filter Default Configuration

Configuration	Default (command)	Default (value 1)
\$SPEED FILTER STATE _	ENABLED	-
\$SPEED_FILTER PRESET SET _	-	1

Table 20: Course Over Ground (Heading) Default Configuration

Configuration	Default (command)	Default (value 1)
\$COG_FILTER STATE _	ENABLED	-
\$COG_FILTER PRESET SET _	-	1

5.2. Product Variants

There are currently two Ultra Smart Antenna variants, whose specifications are shown in the table below. For more information please refer to the website www.nordian.com.

Table 21: Ultra Smart Antennas Variants

#	Specification	Ultra	Ultra+
1	Horizontal Accuracy (RMS)* with corrections	0.03 m**	0.01 m
2	Pass-to-Pass Accuracy	0.02 m	0.01 m
3	Convergence Time	<30 s	<10 s
4	Position Update Rate	50 Hz	50 Hz
5	Serial Speed Communication	460800 bps	
6	Max CAN FD Port Speed	8 Mbps	
7	Power Supply	+7 to +32 VDC	
8	Multi Constellation GPS + GLO + GAL + BDS	✓	✓
9	Universal Input & Output	✓	✓
10	Remote Access and Diagnostics	✓	✓
11	IMU High-Grade 6-Axis	✓	✓
12	GNSS+IMU Sensor Fusion	✓	✓
13	Terrain Compensation	✓	✓
14	Year-to-Year Repeatability	✓	✓
15	Ground Speed Output (Pulses)	✓	✓
16	Wi-Fi and Bluetooth (optional)	✓	✓

#	Specification	Ultra	Ultra+
17	IP or Satellite Corrections	✓	✓
18	PPP-RTK Technology	✓	✓
19	Cellular Communication	✓	✓
20	External RF Antenna for RTK		✓
21	Internal Radio for RTK Corrections		✓

*Depends on open-sky environment, multipath and number of satellites in view

**When you have an active Ultra L-Band or IP subscription.

5.3. Warranty

All Ultra Smart Antenna devices are covered by a 12-month warranty, starting from the date of shipment. During this period, Nordian Inc. will repair or replace – at no cost – any device found to be defective.

The warranty does not apply if the device has been subjected to negligence, misuse, improper storage, operation beyond specified limits, incorrect application, physical damage, internal modifications, or repair by personnel not authorized by Nordian Inc.

Please note that occasional, non-recurring errors or malfunctions that do not affect continuous operation are not considered valid grounds for a warranty claim.

5.4. Support

For specific support, doubts and warranty claim, contact Nordian Inc at:

Website: www.nordian.com

Customer Service: support@nordian.com

6. Firmware Update

6.1. Nordian Application Software

Nordian disposes of a proprietary software aimed for serial communication with Ultra, as well as for its firmware update. To proceed with the firmware update please refer to the Nordian website www.nordian.com/support and download the software executable. The software doesn't require installation, simply run the executable.

The software has a serial terminal interface that can be used to communicate with Ultra. The figure below shows the software interface and its main communication functionalities.

Figure 22: Nordian Application Interface

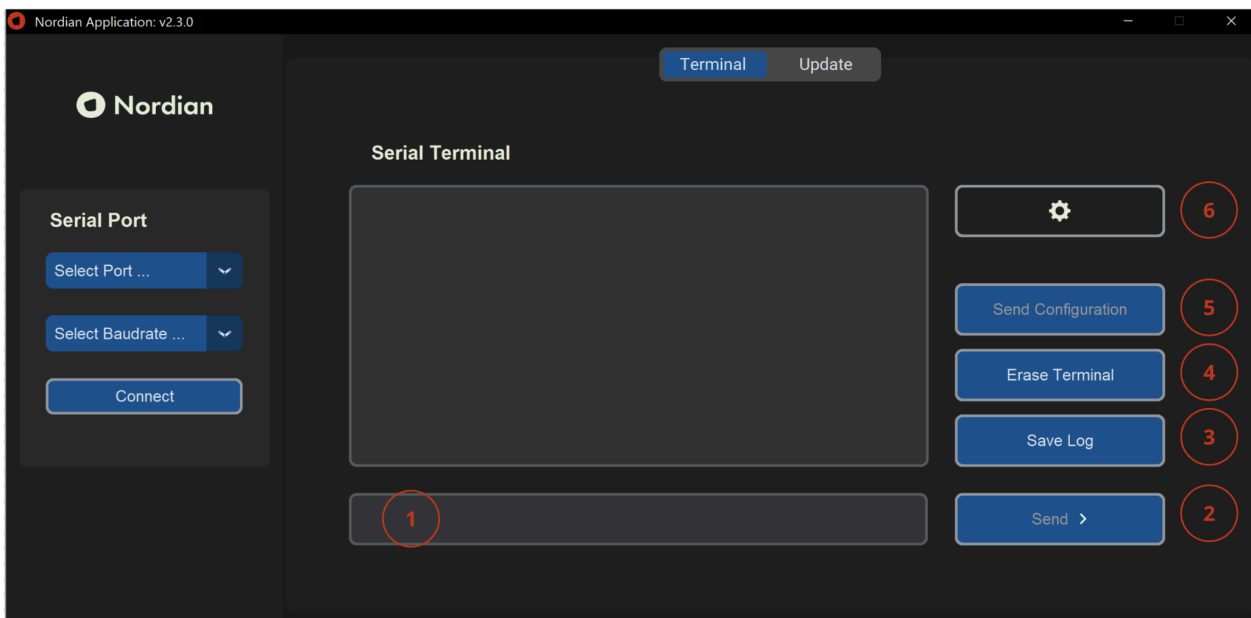

Legend:

- 1) Serial terminal command line: write here the commands according to the Ultra Commands Manual.
- 2) Send Command: after writing the command click on this button to send it to the Ultra.
- 3) Save Log: If the user selects a file, the terminal data will be saved to that file until the user clicks at "Stop Logging".
- 4) Erase Terminal: click here to erase the Serial terminal for better visualization.
- 5) Send Configuration: after loading a command script click here to send it to the Ultra.

- 6) Load Command Script: a series of commands can be written in a text document and loaded using this button. This is useful if a series of Ultra devices shall be configured in the same way, thus the process can be done in a semi-automated way.

NOTE: remember to always connect Ultra to the correct port and select the correct serial baudrate (default 115200).

6.2. Firmware Update

Ultra comes with a fully functional firmware already installed. Yet, due to Nordian's continuous improvement, new firmware versions may be available online at www.nordian.com/support, without notification.

If Ultra presents an unexpected behavior and/or the Status LEDs indicate a possible firmware issue, follow the instructions to update the firmware. Furthermore, if a new firmware version is available it is always recommended to update the firmware.

Follow the instructions below in order to update the firmware.

- 1) Connect Ultra: connect Ultra to the correct serial port with the correct baudrate. If the chosen baudrate doesn't match Ultra's baudrate the software will remain idle, without properly communicating, thus updating won't be possible.

In the figure below, Ultra is being connected to the software via COM21 and with 115200 (default) baudrate. The software will automatically identify the available ports. Note that all peripheral devices will be identified as a possible connection port, it's up to the user to identify the correct one.

Once the port and baudrate are selected press "Connect", if the connection is successful the button will update to "Disconnect", which means that when pressed it will disconnect Ultra.

Figure 23: Nordian Application Connection

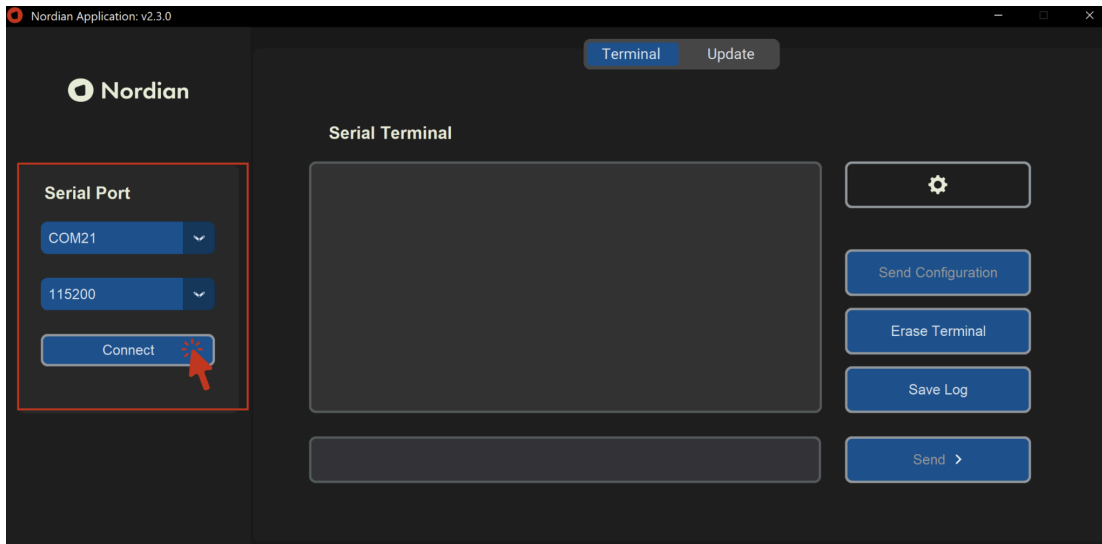

- 2) Load Firmware File: access www.nordian.com/support and download the firmware file (.ndn). Click on the folder icon and select the .ndn file. Once selected, the software will indicate that the firmware file corresponds to a valid firmware. It will show the version of the firmware and the corresponding product.

Once the firmware file has been read by the software the folder icon will turn green. If Ultra is correctly connected to the software the “Update” button will be enabled. Press the button to begin the firmware update, as shown in the figure below.

Figure 24: Firmware Update Screen

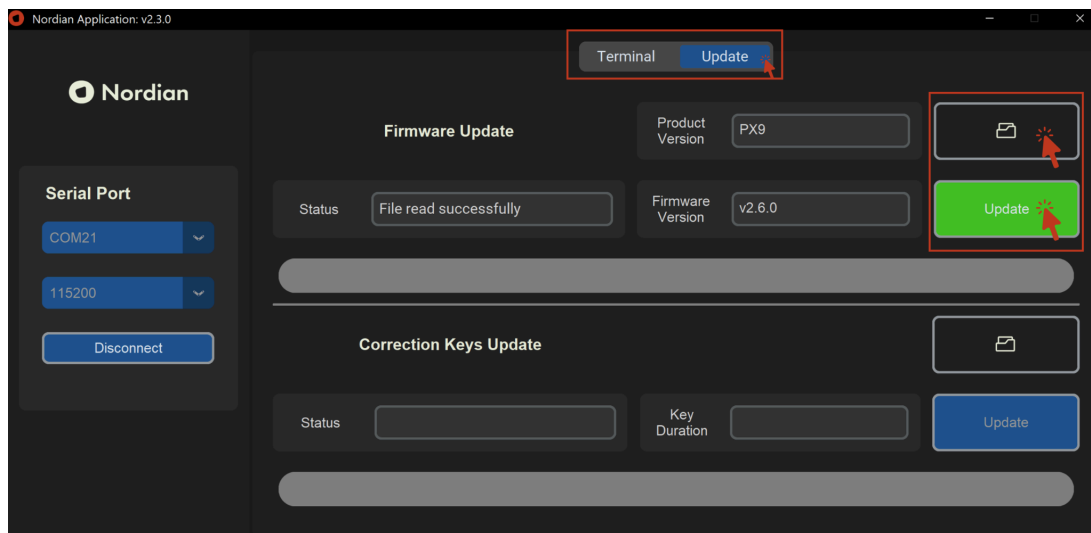

- 3) Update Successful: if the update process is successful the “Update Successful!” message shall be displayed on the Update Status field, as shown in the figure below. If any communication or power failure occurs during the firmware update process the software must be closed and the process must be restarted.

Once the process is finished disconnect Ultra and close the software. Ultra is ready to use.

NOTE: always check the Status Leds after the update process to verify if it has been successful. Restart the process if any issue is identified.

Figure 25: Firmware Update Successful

