



OWNER'S MANUAL  
VERSION [ 1.1 ] APRIL 2026

**U·D·O**



8 VOICE POLYPHONIC DUAL MODULE  
BINAURAL ANALOG-HYBRID SYNTHESIZER  
WITH DYNAMIC SIGNAL ARCHITECTURE

UDO DMNO  
OWNER'S MANUAL

©2026 UDO AUDIO  
VERSION 1.1 · APRIL 2026

[UDO-AUDIO.COM](http://UDO-AUDIO.COM)

# TABLE OF CONTENTS

---

<b>Important Safety Instructions</b>	<b>8</b>
<b>Acknowledgements</b>	<b>10</b>
<b>Introduction</b>	<b>11</b>
<b>What is the DMNO?</b>	<b>12</b>
<b>Getting Started</b>	<b>14</b>
Setting up the DMNO	15
Using the Display	17
There's More to It Than That: Shift Mode	18
What You See Is What You Get: Manual Mode	18
Performances and Patches	19
Loading Performances and Patches	19
Editing Performances and Patches	21
Starting from the Init Patch	22
Spy Mode	23
Swapping and Copying Layers	24
Comparing Performances and Patches	25
Saving Performances and Patches	25
Level Up!	26
<b>Connections</b>	<b>27</b>
<b>The Synthesizer Modules: DMNO 1 &amp; 2</b>	<b>30</b>
Oscillators	30
Oscillator Controls	32
Oscillator Modulators	33
VCF (Voltage-Controlled Filter)	36
LFO 1 (Low Frequency Oscillator 1)	40

Envelopes	44
ENV 1 (Envelope 1)	45
ENV 2 (Envelope 2)	47
<b>The Mixer</b>	<b>49</b>
<b>Performance Control Section</b>	<b>51</b>
The Bender	52
LFO 2 (Low Frequency Oscillator 2)	53
Portamento	55
Octave Selector & Transpose Function	55
Module Selection	56
<b>Play Modes</b>	<b>57</b>
<b>Voice &amp; Filter Settings</b>	<b>59</b>
Voice Assignment	60
ENV 3 Parameters	61
LFO 2 Parameters	62
Voice Variation	63
User-Configurable Waveforms	64
Randomisation Settings	65
Envelope Follower	66
Filter Settings	67
Filter Modulations	69
<b>Modulation Settings</b>	<b>70</b>
Using the Modulation Matrix	71
Modulation Sources	72
Modulation Destinations	72
Predefined Modulation Routings	73
<b>Arpeggiator</b>	<b>74</b>
Arpeggiator Controls	74
Arpeggiator Settings	76

General Settings	76
MIDI Settings	78
Swing Settings	78
Clock Controls	79
<b>Effects &amp; Equalizer</b>	<b>80</b>
Drive	81
Chorus	82
Equalizer	83
Delay	84
Delay Freeze	86
Reverb	87
<b>Global Settings</b>	<b>88</b>
General MIDI Settings	89
Edited Parameter Settings	89
Program Change Settings	90
Dumping Performances and Patches	90
Local Control	91
Tuning Settings	92
MPE Settings	92
Inputs and Outputs	93
Resetting the Global Parameters	98
<b>Updating the Firmware</b>	<b>99</b>
<b>Managing Files</b>	<b>100</b>
File Name Convention	101
Importing Performances and Patches from Your Computer	102
Importing Waveforms from Your Computer	103
Backing up Performances and Patches on Your Computer	104
Backing up Waveforms on Your Computer	104
Creating Your Own Alternative Waveforms	104

<b>MIDI Specifications</b>	<b>105</b>
System Real-Time Messages	105
Channel Messages	105
<b>Glossary</b>	<b>106</b>
<b>Support Information</b>	<b>112</b>

## **NAVIGATION**

**IMPORTANT SAFETY  
INSTRUCTIONS**

**ACKNOWLEDGEMENTS**

**INTRODUCTION**

**WHAT IS THE DMNO?**

**GETTING STARTED**

**CONNECTIONS**

**THE SYNTHESIZER  
MODULES: DMNO 1 & 2**

**THE MIXER**

**PERFORMANCE CONTROL  
SECTION**

**PLAY MODES**

**VOICE & FILTER SETTINGS**

**MODULATION SETTINGS**

**ARPEGGIATOR**

**EFFECTS & EQUALIZER**

**GLOBAL SETTINGS**

**UPDATING THE FIRMWARE**

**MANAGING FILES**

**MIDI SPECIFICATIONS**

**GLOSSARY**

**SUPPORT INFORMATION**

# Navigation

Use the interactive index section to the left of each page to navigate through the individual sections of this document.





# IMPORTANT SAFETY INSTRUCTIONS



THE FOLLOWING SAFETY REQUIREMENTS MUST BE ADHERED TO FOR PREVENTION OF FIRE, ELECTRIC SHOCK OR INJURY:

1. Read all the instructions before using the musical instrument.
2. Do not disassemble or modify the musical instrument.
3. Never attempt to repair this device or replace parts. If repair or part replacement should become necessary, you must contact your dealer. There are no user-serviceable parts inside the musical instrument.
4. Never place the musical instrument in an unstable location. A musical instrument set may fall, causing serious personal injury. Many injuries, particularly to children, can be avoided by taking simple precautions such as:
  - Only using cabinets or stands that can safely support the musical instrument and have an adequate load rating
  - Ensuring that the musical instrument is level and stable before use
  - Ensuring the musical instrument is not overhanging the edge of supporting furniture, which could cause the musical instrument to topple
  - Not placing the musical instrument on tall furniture (for example, cupboards or bookcases) without anchoring both the furniture and the musical instrument to a suitable support
  - Not placing the musical instrument on cloth or other materials that may be located between the musical instrument and supporting furniture or stand
  - Educating children about the dangers of climbing on furniture to reach the musical instrument
5. Do not use or store the musical instrument in the following types of locations:
  - Locations exposed to rain
  - Locations of excessive dust
  - Locations subject to heavy vibration
  - Locations of extremely high temperature (such as in direct sunlight, near heating equipment, or on a device that generates heat, or near naked flames or candles)
  - Near moisture (such as in a bathroom, near a sink, or on a wet floor) or in locations of high humidity
6. Do not stand on the musical instrument, or place heavy objects on it.
7. Do not drop the musical instrument.
8. The musical instrument should only be powered from an electrical outlet which provides a voltage within the ratings of the instrument and provides an earth connection. Connection to any supply voltage outside the rated range, or a supply without an earth connection, can cause permanent damage and serious personal injury.
9. Only use the power cord included with the device. Do not attempt to modify or disassemble the power cord. If replacing the fuse in the power cord, always replace it with a fuse of the same type.
10. Do not place heavy or sharp objects on the power cord, as this could damage the power cord and render it unsafe. If damage to the power cord is suspected, disconnect it from the electrical outlet if safe to do so, do not use the power cord and contact your dealer.
11. Do not place any containers which contain liquids on or near the musical instrument.
12. Do not allow foreign objects or liquids to enter the musical instrument, as this can cause permanent damage and may result in serious personal injury and possible ignition of the liquid if flammable. If damage from foreign objects or liquids entering the musical instrument is suspected, do not use the musical instrument, disconnect from the electrical outlet and contact your dealer.

13. Do not use the musical instrument, disconnect from the electrical supply and contact your dealer if any other serious malfunction is suspected, for example by:
  - The musical instrument becoming wet (by rain, etc.)
  - The musical instrument becoming hot
  - Generation of smoke or an unusual smell
  - Repeated abnormal behaviour
  - Visible damage to the enclosure, for example large dents or holes in the enclosure
14. If the musical instrument is to be used by children, the children must always be supervised by an adult.
15. Ensure that the connected cables are organised and managed in a safe manner, and do not cause an electrical or trip hazard.
16. When you need to transport the musical instrument, package it in the box (including padding) that it came in, otherwise damage during transport could occur.
17. Unplug the power supply from the outlet when left unused for long periods of time or during lightning storms.

## Electrical Specifications

Rated input voltage:	90~240 VAC
Rated input frequency:	47-63 Hz
Power consumption:	50 W
Fuse type:	2A T-type

## Note

This device has been tested and complies with Part 15 of the FCC Rules. Operation is subject to the following two conditions:

1. This device may not cause harmful interference.
2. This device must accept any interference received, including interference that may cause undesired operation.

## Caution

This product is not user serviceable. All servicing should be carried out by qualified personnel only. Please note that any changes or modifications made to this product not expressly approved by UDO Audio Ltd. could void the user's authority granted by the FCC to operate the equipment.

# ACKNOWLEDGEMENTS

---

Alex4, GSF Agency, Hand in Hand Distribution, Axel Hartmann, Edgar Kine, Alexandros Liarokapis, Paula Maddox, Hazel Mills, Dan Parks, Resonance Design Group, Hendrik Rüffel, Frank Rüffel, Sonicstate, Toshihide Ueda and Angell Yu.

## The UDO Team

Phillip Anthony, Ben Charlton, Joseph Collins, George Hearn, Magnus Hearn, Mike Hiegemann, Louis Richards and Jamie Tucker.

Manual and illustrations by Mike Hiegemann.

# INTRODUCTION

---

Hello and welcome to your new UDO synthesizer. What sits in front of you represents the dawn of a new frontier in the UDO sound, an instrument crafted over several years to be familiar in spirit, yet unique in character. If you already know our instruments, DMNO will lead you into unexpected territory. If this is your first experience with UDO, welcome.

I am honoured to have made this instrument for you, and I hope you have as much fun playing it as I do.

There's magic in synthesizers that goes far beyond the end-result: a magic in the doing — in the space between intention and outcome, in the interactions between code, circuitry, metal and motion. That magic doesn't always reveal itself politely. Sometimes it emerges through friction, challenge, or surprise. DMNO was shaped with this in mind, an instrument that doesn't insist on perfection, but rewards play, exploration, and curiosity.

DMNO was not conceived as a successor to the Supers, but as a companion to them. It continues UDO's dedication to making instruments that are hands-on, intuitive and fun, while introducing a wealth of new technologies and techniques. DMNO can sing sweetly, but it also invites you to push further: to lean into edges, to discover sounds that feel unsettled, unruly, or unfamiliar. There are no wrong turns here, only new outcomes.

I hope you find moments with this instrument that surprise you, challenge you, or simply feel *right* in ways that are difficult to explain. The most significant part of this journey is now in your hands. Enjoy.



George Hearn,  
Director UDO Audio Ltd.

# WHAT IS THE DMNO?

The DMNO is a portable 8-voice, bi-timbral synthesizer with a flexible and dynamic sound architecture, dedicated performance controls and a 44-note Fatar keyboard with velocity and channel aftertouch. It features two fully independent 4-voice hybrid synthesizer modules, DMNO 1 and 2, each equipped with a pair of ultra-precision FPGA-based digital oscillators, our new dynamic multi-core stereo filter, a binaural signal path, and its own complete set of front panel controls, allowing you to program and edit patches simultaneously.

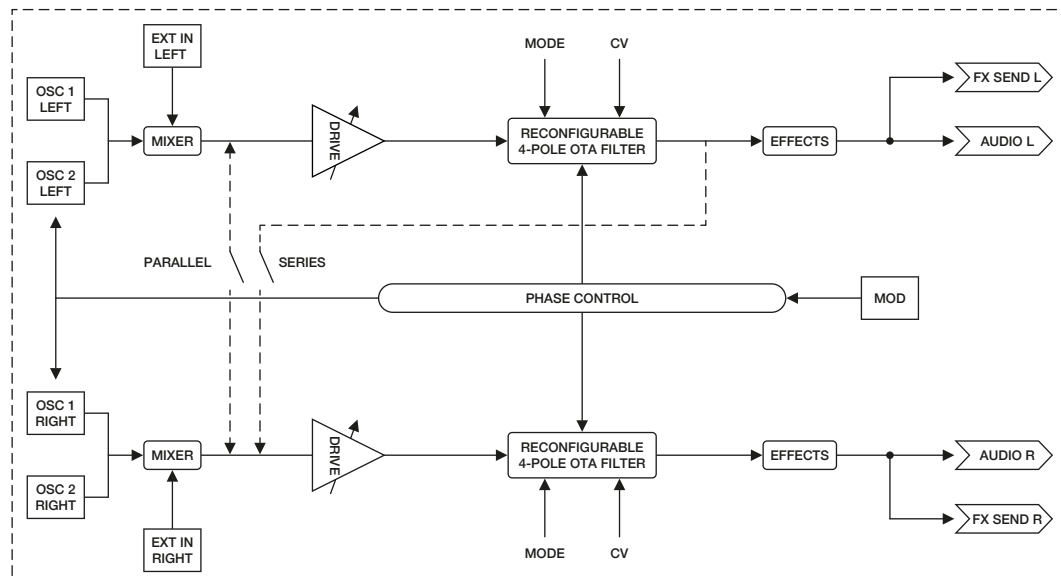

The signal path of each DMNO synthesizer module.

The DMNO features a high-resolution digital effects engine capable of delivering subtle to extreme sounds that always remain musical. In addition, you can use the integrated arpeggiator to create individual rhythm patterns with either of the two synthesizer modules, facilitating the creation of polymeric patterns.

Thanks to its connections, the DMNO can serve as a Swiss Army knife in any setup. An integrated USB audio interface enables direct multi-channel connection to your computer or DAW, while an audio input with envelope follower, assignable aux outputs, and a pair of assignable CV and gate outputs allow you to use the DMNO as an effects unit, a flexibly routable sound generator, or a control hub for your modular setup. The best part is that you can utilise all of these options at once.

The DMNO's display puts everything at your fingertips, from navigating through performances and patches to exploring additional parameters, creating modulation routings, editing effects, programming sequences and much more. Every parameter is exactly where you need it, without having to navigate through deep menus or perform tedious searches – all presented on the best screen we could find: a beautifully sharp yet warm and organic-looking electroluminescent vacuum fluorescent display (VFD).

The real magic unfolds when you use the DMNO's various Play modes, which together form the most central and, dare we say, most fun feature of the instrument, as they enable you to determine how the two synthesizer modules interact with each other, ranging from splits and layers to dynamic, unpredictable chain reactions that randomise and reroute the signal flow. With just a single control, the entire system can be playfully transformed to instantly achieve new behaviours, new sounds or happy accidents – just like with dominoes, where one element triggers the next, which in turn sets further processes in motion.

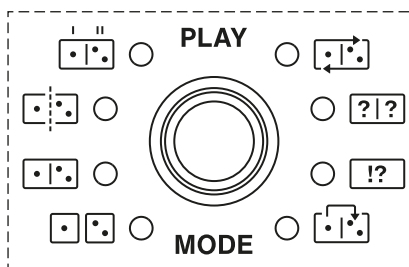

Play Modes: Change your game.

# GETTING STARTED

The DMNO was designed for hands-on performance and experimentation. All the essential controls are accessible directly on the front panel, making programming an incredibly intuitive experience that will fuel your creativity in the studio and on stage.

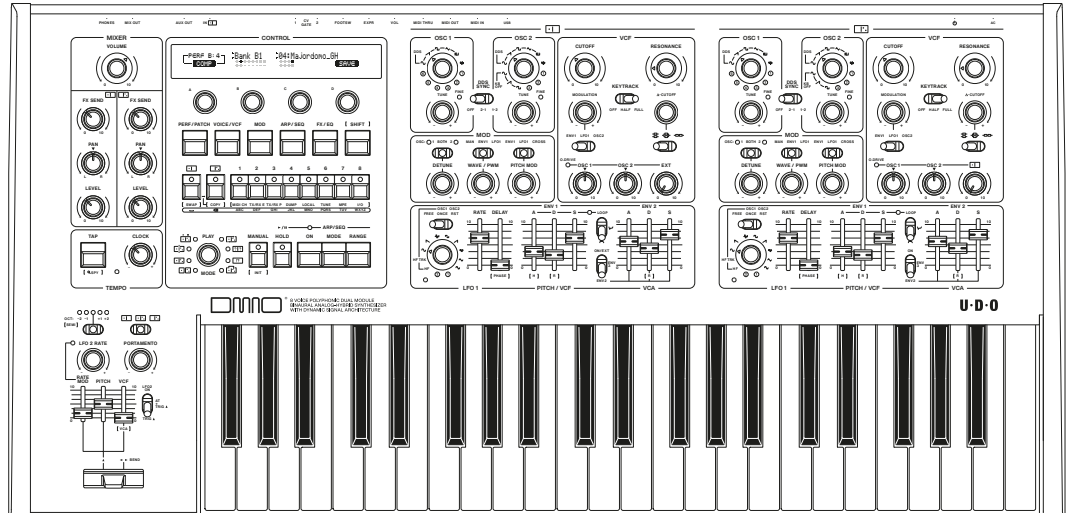

The front panel of the DMNO.

Exploration and experimentation are downright encouraged. The best way to learn how your new instrument works is to dive right in! So get started right away and create your own sounds by either tweaking a preset or starting from scratch with the Init Patch as your starting point (see page 22).

You can always come back later and read more about each of the sound shaping parameters in the following chapters of this manual. We hope you have as much fun playing and tweaking your new instrument as we do!

# Setting up the DMNO

Follow these steps to set up your brand-new instrument:

1. Connect the supplied power cord to the power connector.
2. Use unbalanced 6.35 mm jack cables to connect the outputs labelled **MIX OUT** to your amplifier, mixer or audio interface, or connect headphones to the headphone output.
3. If you own an expression pedal, connect it to either the **VOLUME PEDAL** input to control the volume, or to the **EXPRESSION PEDAL** input to control various parameters such as the filter cutoff frequency. If you own a sustain pedal, connect it to the **SINGLE/DOUBLE FOOTSW** input.
4. Switch on the DMNO and set the **VOLUME** control to a suitable level.
5. Press the **PERF/PATCH** button, depending on whether you wish to load performances or patches, use the red **DMNO** buttons to select a layer to load a patch into, and turn encoders **B** and **C** to scroll through the banks and performances or patches. To load a performance or patch, press encoder **C**. You can also use the numbered buttons (**1-8**) to load a performance or patch within the current bank.

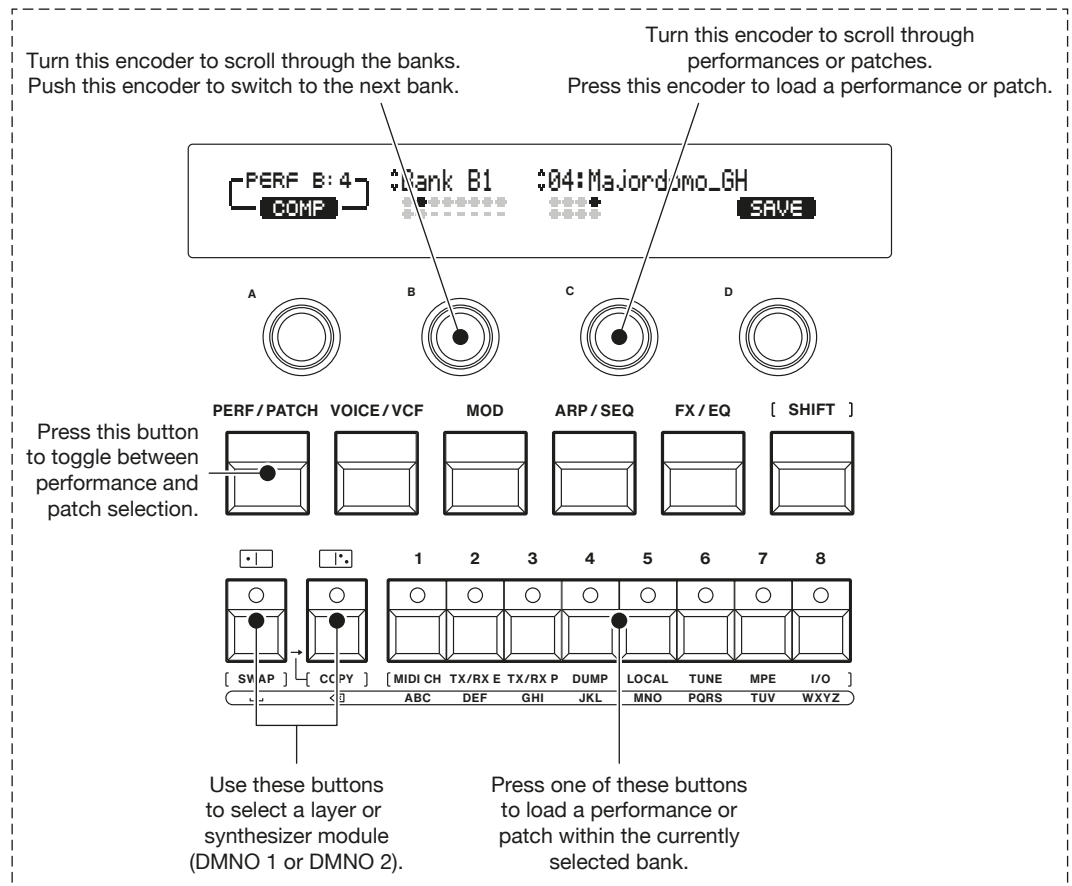

The controls for loading performances or patches.

NAVIGATION

IMPORTANT SAFETY INSTRUCTIONS

ACKNOWLEDGEMENTS

INTRODUCTION

WHAT IS THE DMNO?

GETTING STARTED

CONNECTIONS

THE SYNTHESIZER MODULES: DMNO 1 & 2

THE MIXER

PERFORMANCE CONTROL SECTION

PLAY MODES

VOICE & FILTER SETTINGS

MODULATION SETTINGS

ARPEGGIATOR

EFFECTS & EQUALIZER

GLOBAL SETTINGS

UPDATING THE FIRMWARE

MANAGING FILES

MIDI SPECIFICATIONS

GLOSSARY

SUPPORT INFORMATION

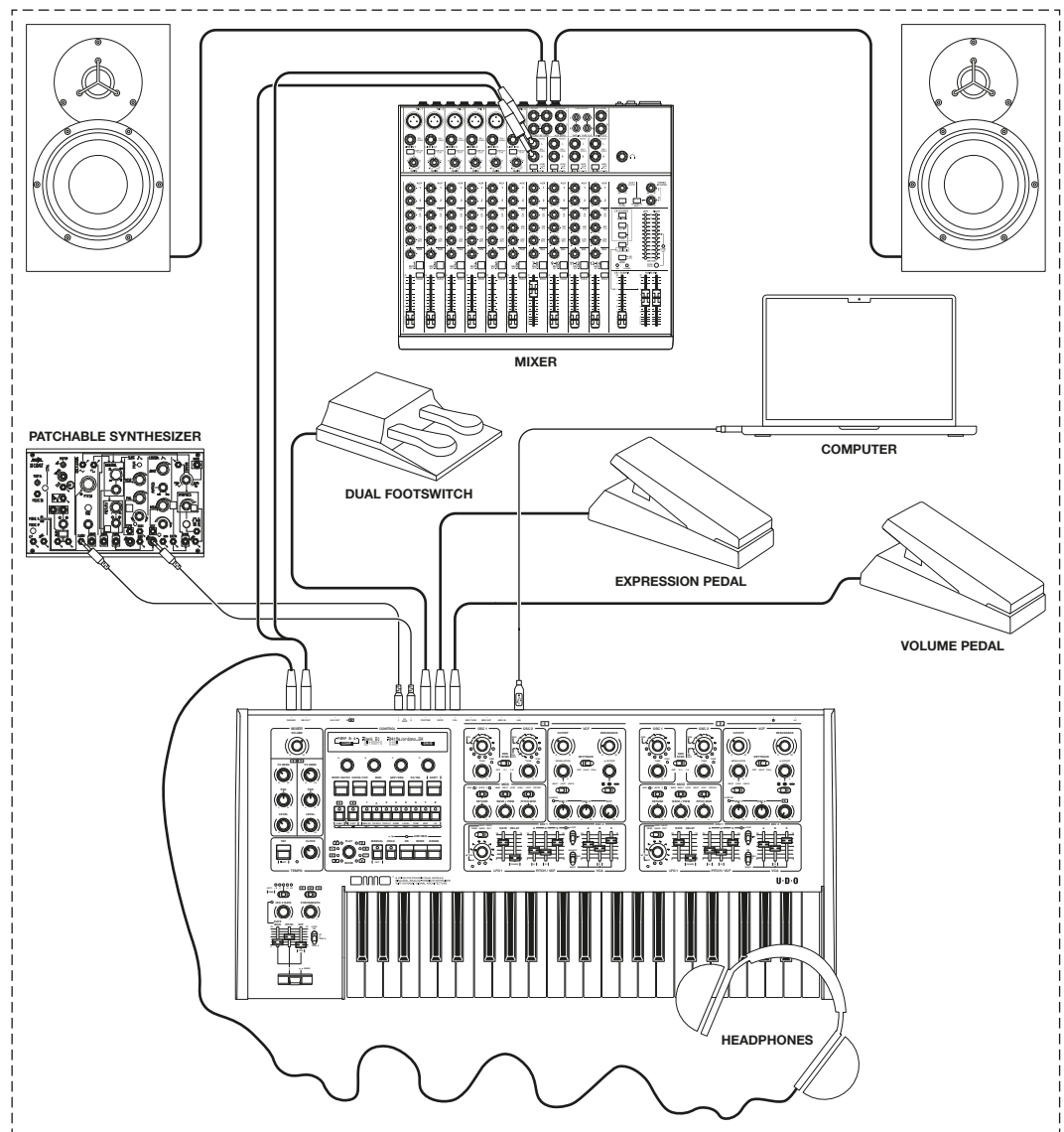

One of many ways to set up the DMNO.

# Using the Display

The most frequently used parameters of the DMNO are located on the front panel and are directly accessible via corresponding controls. The values and options for the individual parameters appear in the display as soon as you adjust a control. After a timeout, the display returns to the previously active page.

The display also allows you to access context-sensitive menus, depending on which control you are currently operating or when you press one of the four menu buttons below the display (labelled **VOICE/VCF**, **MOD**, **ARP/SEQ** and **FX/EQ**).

While each menu shows a different set of parameters, navigating through them always follows the same principle: Below the display are four encoders (**A**, **B**, **C**, **D**) aligned with the up to four columns of each menu. They are used to scroll through options or set a value when turned, or to execute a command when pressed. Each menu displays the number of available options as dots (one of which is highlighted), while commands such as 'LOAD', 'SAVE' or 'COMP' are always presented like a button.

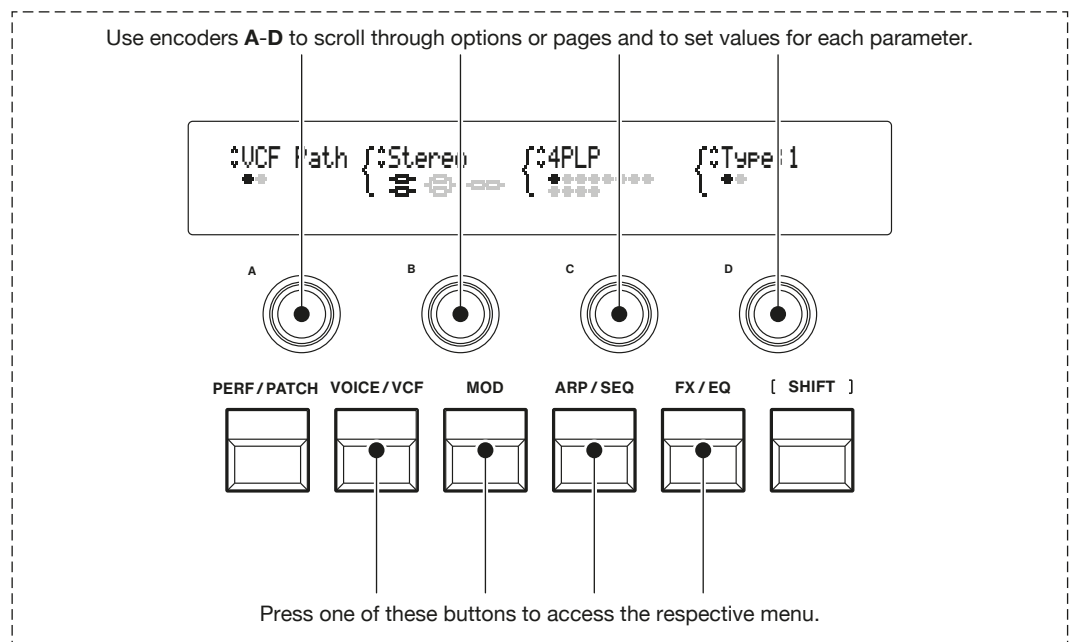

The display area of the DMNO.

## There's More to It Than That: Shift Mode

The **[SHIFT]** button provides access to either Shift mode parameters such as the global settings or secondary parameter functions, which are labelled in square brackets below the respective parameter controls.

- To switch to Shift mode, press and release the **[SHIFT]** button.
- To temporarily access the secondary function of a patch-related parameter (such as **PHASE**, **RELEASE**, or **HOLD**), press and hold the **[SHIFT]** button while moving the respective control. In this case, Shift mode is quit when the **[SHIFT]** button is released.

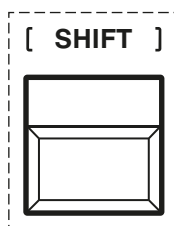

The **[SHIFT]** button.

## What You See Is What You Get: Manual Mode

In Manual mode, the saved patch settings are ignored, and the currently selected layer is prompted to respond to the actual settings of the front panel controls. This is an excellent way to better understand how each control affects the sound. It can also lead to unexpected results!

To enter Manual mode:

1. Select a layer or synthesizer module by pressing one of the two **DMNO** buttons.
2. Press the **MANUAL** button.
3. To return to the saved performances or patches of the currently selected bank, simply press one of the numbered buttons (**1-8**).

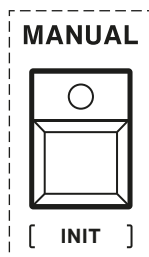

The **MANUAL** button.

# Performances and Patches

A performance is essentially a snapshot of the entire instrument, consisting of the settings for both layers or synthesizer modules (DMNO 1 and 2), the settings for the performance control section, the arpeggiator settings, as well as the voice, effect and mixer settings, with the exception of **VOLUME**, which is a non-storable parameter.

A patch is a saved set of synthesizer parameters for a single layer or synthesizer module.

The DMNO can store up to 128 performances (with 2 patches each) and 128 patches. These are organised into 16 banks (A1-H2), each containing 8 performances or patches. You can edit or overwrite these to save your own performances or patches.

## Loading Performances and Patches

The process for loading a performance or patch is identical. There is only one additional step to consider when loading a patch: You must first use the two red **DMNO** buttons to select the layer or synthesizer module into which you wish to load a patch. Pressing the first **DMNO** button selects DMNO 1 (◻◻), pressing the second **DMNO** button selects DMNO 2 (◻◻).

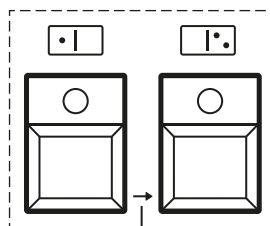

The **DMNO** buttons.

Before loading a performance or patch, access either the performance or patch banks. You can toggle between the two types of banks using the **PERF/PATCH** button.

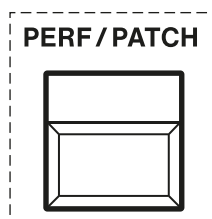

The **PERF/PATCH** button.



The display indicating which type of banks you have selected.

When the performance banks are selected, the word 'PERF' is shown in the upper left corner of the display. When the patch banks are selected, the word 'PATCH' is shown in the upper left corner of the display.



The display when browsing performances.

To load a performance or patch:

1. Turn encoder **B** to scroll through the available banks.
2. Turn encoder **C** to scroll through the available performances or patches within the selected bank.
3. Press encoder **C** to load the selected performance or patch.



*As a shortcut, you can also press one of the numbered buttons (1-8) to load a performance or patch within the currently selected bank.*



*Empty memory locations in banks are indicated by dashes instead of dots.*

# Editing Performances and Patches

A performance is edited as soon as you change any parameter except **VOLUME**.

All patch-related parameters are located in the control sections of the two synthesizer modules DMNO 1 and 2, as well as in the mixer section, where you can balance the output levels, pan the audio signal of both layers or synthesizer modules, and set the individual effect send levels.

The control section between the mixer and the two synthesizer modules, as well as the tempo section, contain controls that are shared by both layers or synthesizer modules. You can switch between the layer-specific settings controlled in these sections, such as the arpeggiator or effect settings, by using the two red **DMNO** buttons mentioned above. Their LEDs indicate which layer you are currently editing.

In addition to these sections, you can further shape your sounds in the performance control section to the left of the keyboard by using a second LFO, adding portamento, or playing pitch bends.



*When using encoders **A-D** to edit parameter settings, you can use the push function to cycle through fixed values (e.g. '0', '1/2' and 'Full') or items in a list.*

As soon as a setting is changed, the LED of the currently lit numbered button (**1-8**) starts flashing and an asterisk appears next to the performance or patch name in the display or next to the last parameter changed to indicate that the performance or patch has been edited.

In addition, there are two more visual indicators for parameter values:

1. The current value is displayed either by vertical bars filling a value bar or by a filled circle (for options).
2. The saved value is indicated by a chevron below a value bar or an option circle.

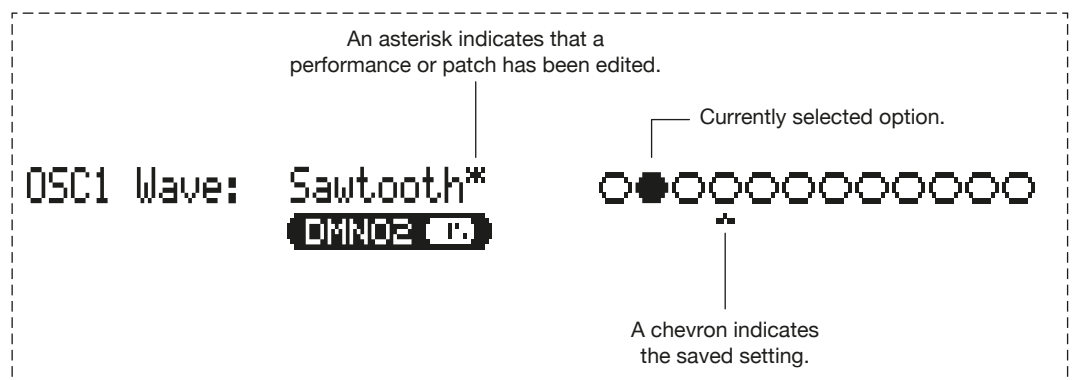

The indicators for an edited performance or patch.

Continue experimenting with the controls on the front panel, and when you find a sound you like, save it as a performance or patch in the currently selected bank by pressing encoder **D** or by pressing and holding one of the numbered buttons (**1-8**) for 3 seconds. For more information on how to save a performance or patch, see page 25.

## Starting from the Init Patch

Although saved performances or patches are an excellent starting point, it often makes sense to start from scratch when creating a new sound. To do this, you can load the so-called Init Patch, which contains a single oscillator set to a sawtooth waveform, along with other basic settings.

To load the Init Patch into either layer or synthesizer module:

- Press the **[SHIFT]** button and then the **MANUAL** button.

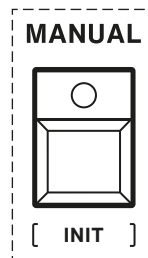

---

The **MANUAL** button and its shift function **INIT**.



*The Init Patch is loaded by default when the DMNO is powered on.*

# Spy Mode

Each time you turn a rotary control or toggle a switch, the corresponding parameter setting appears in the display. However, you will often want to check a setting without having to change the parameter value. This is why we have implemented the so-called Spy mode. In Spy mode, the actual physical position of a control is indicated by a small line below a value bar or an option circle, while a dot following a displayed value indicates that the physical position differs from the active value.

To display a parameter setting without changing it:

1. Press the **[SHIFT]** button and then hold the **TAP [SPY]** button.
2. Continue to hold the **TAP [SPY]** button and adjust any parameter on the front panel to display the saved value, the physical control position and, if applicable, its deviation from the current position.
3. Release the **TAP [SPY]** button to exit Spy mode.

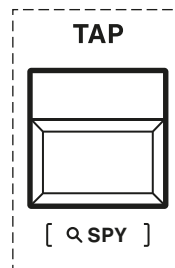

The **TAP [SPY]** button, whose secondary function activates Spy mode.

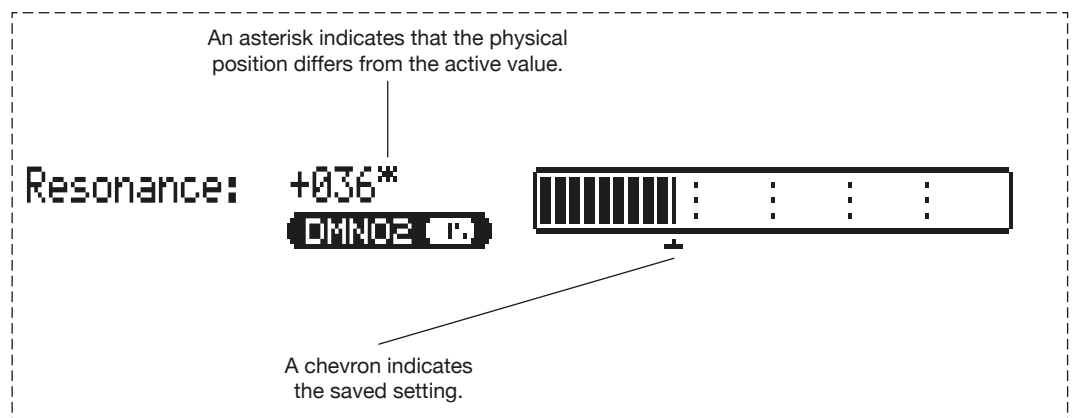

The indicators in Spy mode.

## Swapping and Copying Layers

When a performance is loaded, it can sometimes be useful to swap layers, for example if you want to invert the patches assigned to the two halves of the keyboard in Split mode.

To swap the layers of a performance:

- Press the **[SHIFT]** button and then the first **DMNO** button.

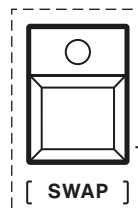

The **SWAP** function is the secondary function of the first **DMNO** button.

At times it can also be useful to copy the patch of one layer to the other layer, for example if you wish to create a particularly dense sound by detuning two otherwise identical layers.

To copy the patch from DMNO 1 to DMNO 2:

- Press the **[SHIFT]** button and then the second **DMNO** button.

To copy the patch from DMNO 2 to DMNO 1:

1. Press the **[SHIFT]** button and then the first **DMNO** button to swap the layers.
2. Press the **[SHIFT]** button and then the second **DMNO** button.

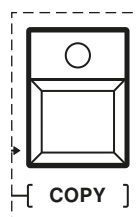

The **COPY** function is the secondary function of the second **DMNO** button.

# Comparing Performances and Patches

Before saving a performance or patch, it can be helpful to first ensure that you are not overwriting a performance or patch that you would still like to use.

To compare an edited performance or patch with a saved performance or patch:

1. After editing a performance or patch, press encoder **A** ('LOAD').
2. To return to the performance or patch you just edited, press encoder **A** ('COMP') again.

# Saving Performances and Patches

To save a performance or patch:

1. Turn encoder **B** to navigate to the desired performance or patch bank.
2. Turn encoder **C** to navigate to the desired memory location within the selected bank.
3. Press encoder **D** to execute the command 'SAVE'. You are now taken to the page where you can name or rename your performance or patch.
4. Turn encoder **A** to move the cursor, turn encoder **B** to select a number or punctuation mark, and turn encoder **C** to select letters.

Alternatively, you can use the two **DMNO** buttons to insert a space or delete a character, and buttons **1-8** to enter letters. To switch between the available letters, repeatedly press each of the numbered buttons. (The available options are printed in the second line below the buttons mentioned above.)

5. Press encoder **D** to execute the command 'DONE'. The display indicates that the performance or patch is now saved.

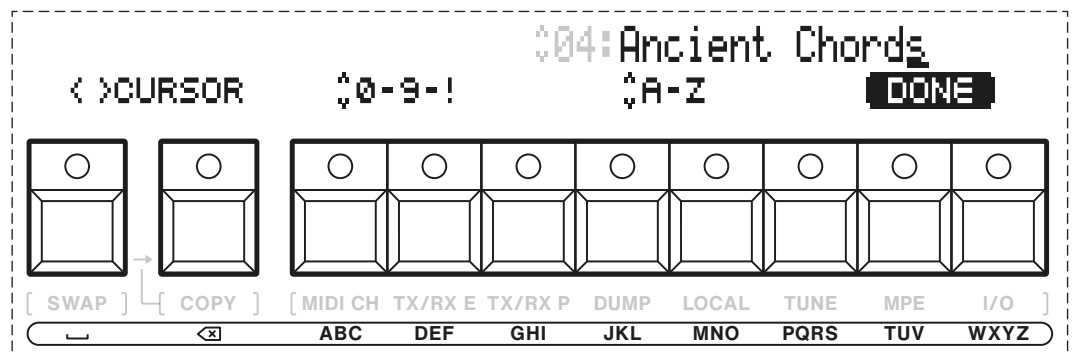

The display and the functions of the **DMNO** buttons as well as the numbered buttons when naming a performance or patch.



---

*When you save a performance, you are essentially saving a snapshot that contains copies of the patches in each layer. Therefore, changes applied to one of the layers are also saved without altering the original patches.*



---

*If you want to save a performance or patch to a memory location within the currently selected bank without naming or renaming it, you can skip the above steps 2-5 by pressing and holding one of the numbered buttons (1-8) for 3 seconds. The edited performance or patch is then saved to the respective memory location.*



---

*If you wish to use a specific layer of a performance as part of other performances, you must save it as a patch.*

## Level Up!

The DMNO was designed to be played and tweaked in real time, and we encourage you to do just that on your journey of discovering and creating new sounds. After all, this is by far the best way to get to know and understand the potential of your new instrument.

All parameter functions and options are explained in more detail in the following chapters of this manual.

For information on adapting the instrument to your specific environment, such as using it with other MIDI instruments or controlling it via a digital audio workstation (DAW) or an external sequencer, refer to the sections on connections and MIDI settings.

This manual also contains some useful hints and tips to help you familiarise yourself with the instrument and its sound shaping parameters.

Enjoy!

# CONNECTIONS



**1. Power Switch:** Use this switch to power cycle the DMNO.

**2. Power Connector:** The AC power connector accepts a standard, grounded IEC power cord.

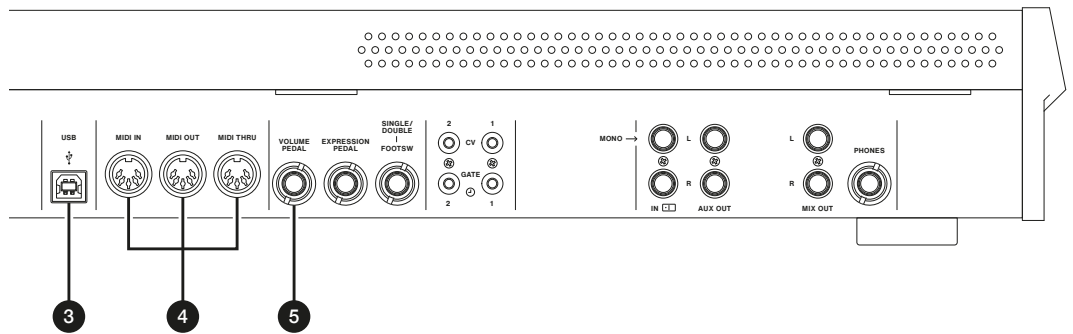

**3. USB Port:** Connect the DMNO to your computer using the included USB cable for bidirectional MIDI communication, file management and firmware updates. The DMNO is class-compliant and does not require any drivers. When connected to a computer, the DMNO can also be used as a 2-ins, 2-outs audio interface. Whatever is routed to its outputs, such as the aux channels of a DAW for playback of a track or an entire mix, is the USB audio signal.

 *Do not connect a USB cable when using the MIDI DIN ports. The simultaneous use of DIN and USB-MIDI is not supported.*

**4. MIDI In, Out and Thru Ports:** Standard 5-pin MIDI DIN connectors.

**5. Volume Pedal Input:** Connect an expression pedal to this input to use it as a volume pedal. This input accepts any standard expression pedal that features a TRS (Tip-Ring-Sleeve) connector and operates with a linear potentiometer over a range of 0 to +5 volts.

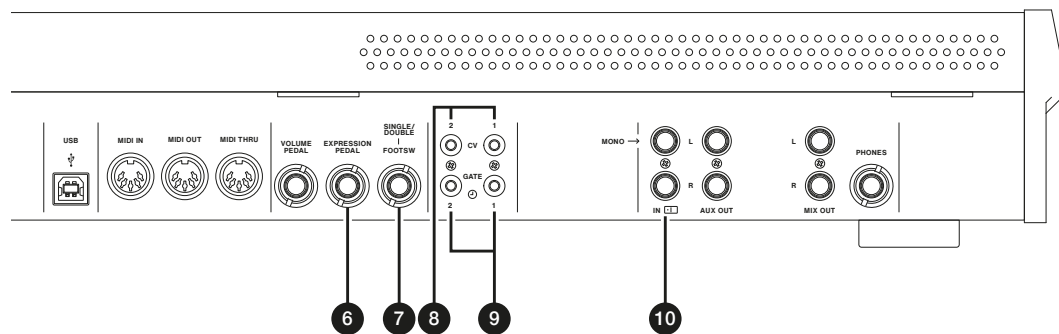

**6. Expression Pedal Input:** Connect an expression pedal to this input to add dynamics to your live performance. There are a variety of options for using an expression pedal, since it is an assignable modulation source in the DMNO’s modulation matrix. This input accepts any standard expression pedal that features a TRS (Tip-Ring-Sleeve) connector and operates with a linear potentiometer over a range of 0 to +5 volts.

**7. Footswitch Input:** Connect a single or dual footswitch to this input to either hold notes that trigger either of the two synthesizer modules, control the delay freeze function, or change performances or patches. The exact functionality of the connected foot switch can be defined via the **I/O** parameters in the global settings. When switched on, the DMNO automatically detects the polarity of the connected pedal. Please note that the state of the footswitch at power-up is taken as its ‘off’ state.

**8. CV Outputs 1 & 2:** These 3.5 mm jacks output a control voltage of 0 to +8 volts, which you can use in conjunction with modular synthesizers and other devices that support this type of connection. The functionality of the CV outputs can be defined via the **I/O** parameters in the global settings.

**9. Gate Outputs 1 & 2:** These 3.5 mm jacks output a 0 to +5 volts on/off control voltage signal, typically used to trigger the envelopes of modular synthesizers and other devices that support this type of connection. The functionality of the gate outputs can be defined via the **I/O** parameters in the global settings.

**10. Audio Inputs (Left and Right):** Connect two unbalanced 6.35 mm mono jack cables to these inputs to feed an external stereo audio signal into the DMNO’s signal path via the first synthesizer module. The inputs feature a variable gain preamplifier, a gate level detector and an envelope follower. The correct level for the envelope follower is set using the **I/O** parameter **Ext. In**, while the audio level of the processed signal is controlled using the **EXT** potentiometer in the mixer of the first module’s filter section. Use only the left input to process a mono signal.

 *If nothing is connected to the audio inputs, they are normalised to the auxiliary outputs.*

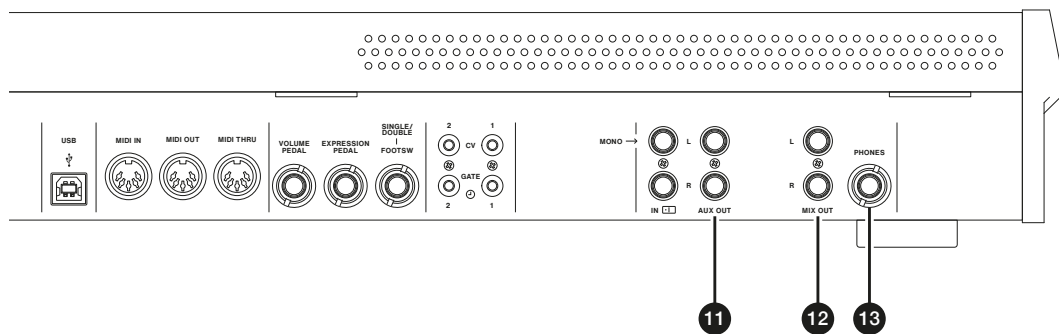

**11. Auxiliary Outputs (Left and Right):** The assignable auxiliary outputs can be configured to output either the main mix output signal, the audio signal from one of the two synthesizer modules or the USB audio signal. The audio source can be defined via the **I/O** parameters in the global settings. Connect both outputs to your mixer or audio interface using unbalanced 6.35 mm jack cables. Use only the left output to send a mono signal.

 *If set to 'USB Audio' and nothing is connected to the audio inputs, the USB audio signal can be fed back into the DMNO.*

**12. Mix Outputs (Left and Right):** This pair of connectors outputs the audio signals of both synthesizer modules as set in the mixer section on the front panel. Connect both outputs to your mixer or audio interface using unbalanced 6.35 mm jack cables. Use only the left output to send a mono signal.

**13. Headphone Output:** Connect a 6.35 mm stereo headphone jack to this output. The overall volume of the headphone output is controlled by the **VOLUME** potentiometer in the mixer section on the front panel.

# THE SYNTHESIZER MODULES: DMNO 1 & 2

This chapter explores the sound design capabilities of the two synthesizer modules, DMNO 1 and 2, by explaining the functions of all patch-specific parameters related to the manipulation of sound. With one exception (see page 39), they are identical for both synthesizer modules.

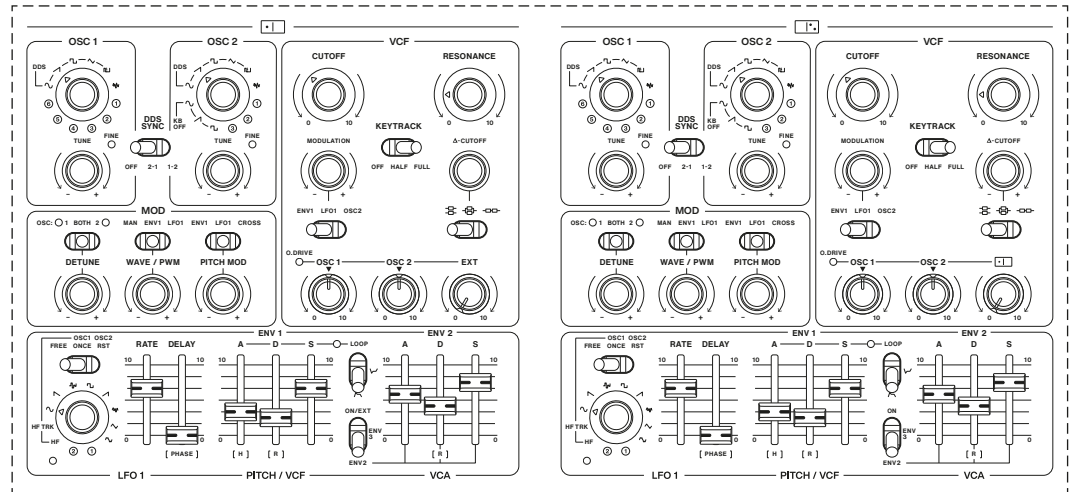

The two synthesizer modules.

## Oscillators

Oscillators are among the most fundamental and essential components of a synthesizer. Without them, you could neither hear a sound nor shape or modulate what is generating an audio signal.

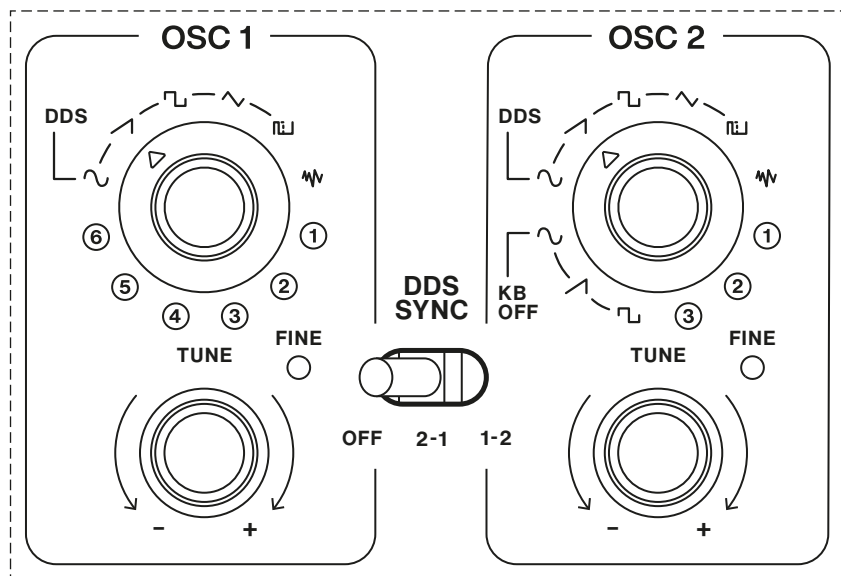

The oscillator section.

Each synthesizer module features two highly precise digital FPGA-based oscillators that utilise our Direct Digital Synthesis (DDS) method to generate an alias-free audio signal. Furthermore, the oscillators are equipped with a so-called Super Waveform oscillator core. It consists of one centroid oscillator and six ‘sister oscillators’ that can be dynamically phase-shifted and detuned in the stereo field using the **DETUNE** encoder. This feature gives the instrument its distinctive rich and broad sound.

Oscillators 1 and 2 are capable of generating classic waveforms such as sine, sawtooth, square, pulse, triangle and white noise.

- A **sine wave** contains only the first harmonic, the fundamental, which is why it is considered the purest waveform. It is ideal for an additional fundamental tone and non-dissonant cross modulation effects.
- A **sawtooth wave** contains both odd and even harmonics and sounds bright. It can be used to create brass, bass and string sounds.
- **Square and pulse waves** contain a variety of odd harmonics. They sound hollow and can be used for reed-like sounds or basses. Apply pulse width modulation to use a pulse wave for swirling string sounds.
- A **triangle wave** contains only odd harmonics and sounds very soft. It is particularly well suited for creating flute or organ sounds.
- **White noise** contains all frequencies and is the most common noise waveform. It is useful for creating wind or percussive sounds.

In addition, the DMNO offers up to 32 rich and complex sounding alternative waveforms. They are user-configurable and allow for an almost unlimited variety of sounds. In contrast to the algorithmically generated classic waveforms, these are single-cycle waveforms. For more information on the user-configurable waveforms, see page 64.

# Oscillator Controls

**WAVEFORM:** Turn this rotary switch to select a waveform for each of the oscillators. You can either select one of the classic waveforms such as sine, sawtooth, square, pulse, triangle and white noise or one of six alternative waveforms for Oscillator 1. With Oscillator 2, you can choose between the six classic waveforms, three alternative waveforms, or non-keyboard-tracked square, sawtooth, and sine waveforms for drones.

**TUNE:** This encoder allows you to coarse or fine tune the frequency of each oscillator within a range of +/-7 semitones. When you press the encoder, the **FINE** LED lights up, indicating that you have entered fine-tuning mode. Use this control to slightly detune the oscillators relative to each other or to create intervals such as fourths or fifths.

**DDS SYNC:** This toggle switch enables oscillator synchronisation, also known as 'hard sync'. When enabled, the synchronised oscillator is forced to restart its duty cycle every time the duty cycle of the oscillator it is synchronised to begins. By setting the frequency of the synchronised oscillator to a higher pitch than the oscillator it is synchronised to, you can create complex and harmonically rich timbres, especially if you modulate the pitch of the synchronised oscillator with an envelope. A famous example of a typical hard sync patch is the lead sound in 'Robot Rock' by Daft Punk. The following options are available:

- **OFF:** If set to this position, oscillator synchronisation is disabled.
- **2-1:** If set to this position, Oscillator 2 is synchronised to Oscillator 1.
- **1-2:** If set to this position, Oscillator 1 is synchronised to Oscillator 2.

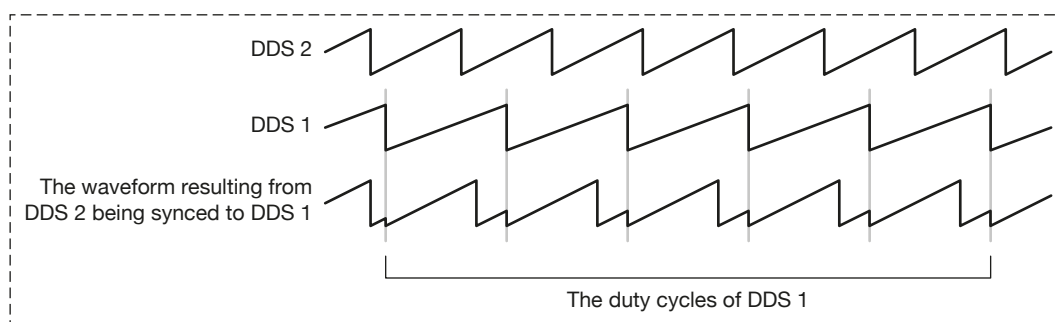

The duty cycle of Oscillator 2 synchronised to Oscillator 1 with both oscillators set to a sawtooth wave.

# Oscillator Modulators

The oscillator modulator section provides dedicated controls for modulating the oscillators to add more sonic variety to your sounds.

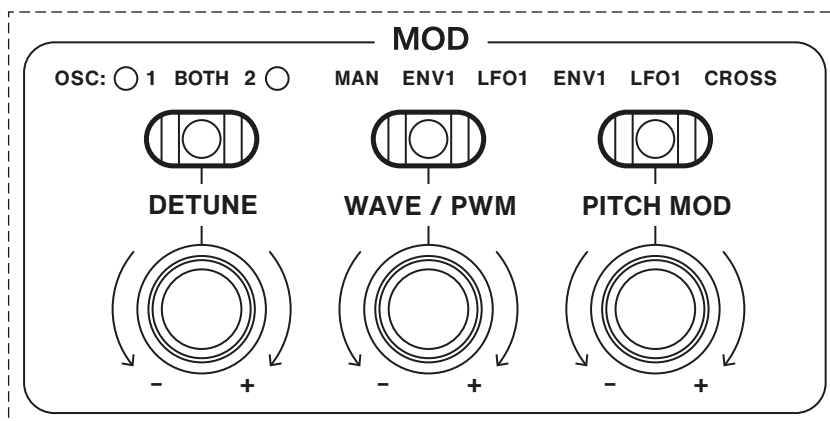

The oscillator modulator section.

The oscillator toggle switch determines which oscillator is modulated by all available modulation types in this section:

- **1:** If set to this position, the modulation is routed to Oscillator 1.
- **BOTH:** If set to this position, the modulation is routed to both oscillators.
- **2:** If set to this position, the modulation is routed to Oscillator 2.

**DETUNE:** This parameter takes advantage of the Super Waveform oscillator core and controls the amount of detune spread applied to either or both oscillators. Increasing the amount will make the sound of the oscillators noticeably thicker as stacked versions of the same waveform are detuned in the stereo field.

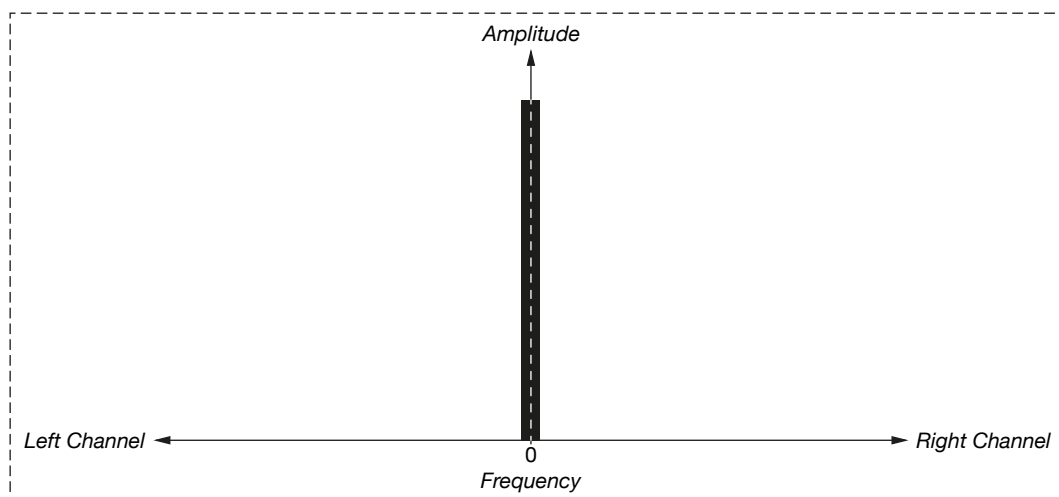

The centroid oscillator. When **DETUNE** is set to 0%, only this oscillator generates a sound.

NAVIGATION

IMPORTANT SAFETY INSTRUCTIONS

ACKNOWLEDGEMENTS

INTRODUCTION

WHAT IS THE DMNO?

GETTING STARTED

CONNECTIONS

THE SYNTHESIZER  
MODULES: DMNO 1 & 2

THE MIXER

PERFORMANCE CONTROL SECTION

PLAY MODES

VOICE & FILTER SETTINGS

MODULATION SETTINGS

ARPEGGIATOR

EFFECTS & EQUALIZER

GLOBAL SETTINGS

UPDATING THE FIRMWARE

MANAGING FILES

MIDI SPECIFICATIONS

GLOSSARY

SUPPORT INFORMATION

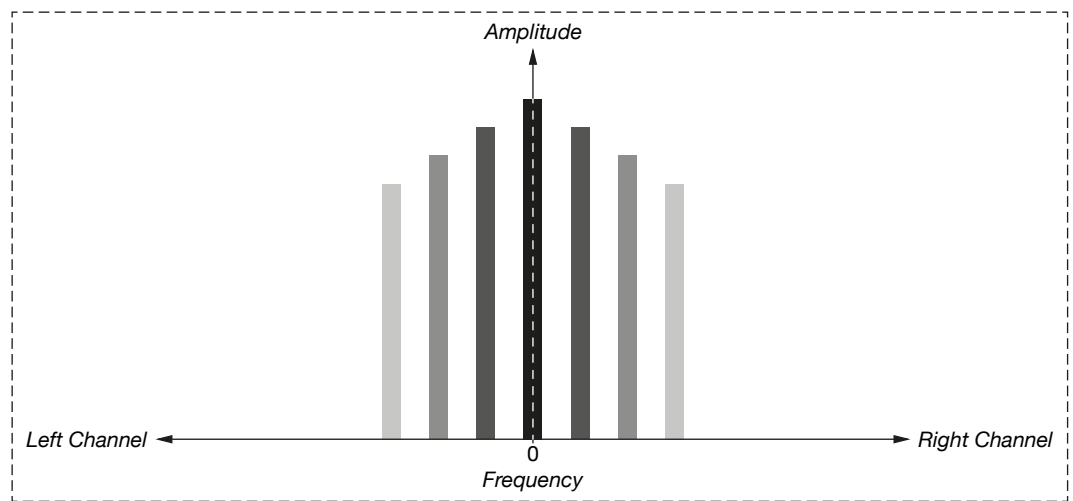

The centroid oscillator and its six sister oscillators spread to both sides when **DETUNE** is set to 50%.

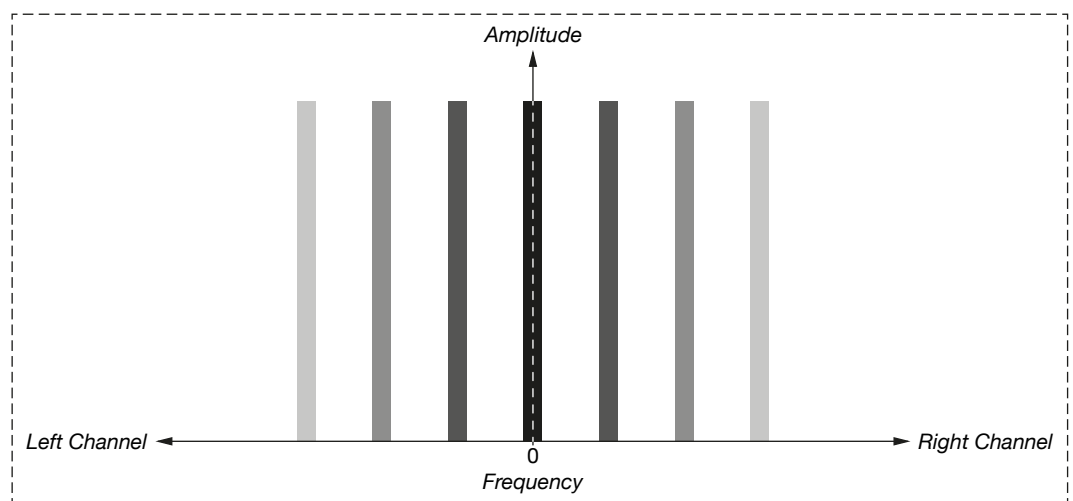

The centroid oscillator and its six sister oscillators spread to both sides when **DETUNE** is set to 100%.

The toggle switch above the **WAVE/PWM** encoder determines what modulation source is used for pulse width or wave modulation:

- **MAN:** If set to this position, the modulation is controlled manually, i.e. by turning the **WAVE/PWM** encoder.
- **ENV 1:** If set to this position, the modulation is controlled by Envelope 1.
- **LFO 1:** If set to this position, the modulation is controlled by LFO 1.

**WAVE/PWM:** This encoder controls the amount of pulse width or wave modulation applied to either or both oscillators. Wave modulation allows you to crossfade between two adjacent waveforms (from sine to sawtooth, sawtooth to square, etc.).

The toggle switch above the **PITCH MOD** encoder determines what modulation source is used for pitch modulation:

- **ENV 1:** If set to this position, the modulation is controlled by Envelope 1.
- **LFO 1:** If set to this position, the modulation is controlled by LFO 1.
- **CROSS:** If set to this position, the **PITCH MOD** encoder is used to adjust the amount of cross modulation. If the oscillator toggle switch is set to **1**, Oscillator 2 modulates Oscillator 1. If the oscillator toggle switch is set to **BOTH**, both oscillators modulate each other recursively. If the oscillator toggle switch is set to **2**, Oscillator 1 modulates Oscillator 2.

**PITCH MOD:** This encoder controls the amount of pitch modulation applied to either or both oscillators.

## VCF (Voltage-Controlled Filter)

The filter section is an essential part of the instrument's unique sonic character and allows you to shape the sound of the oscillators by changing the harmonic content of their signals.

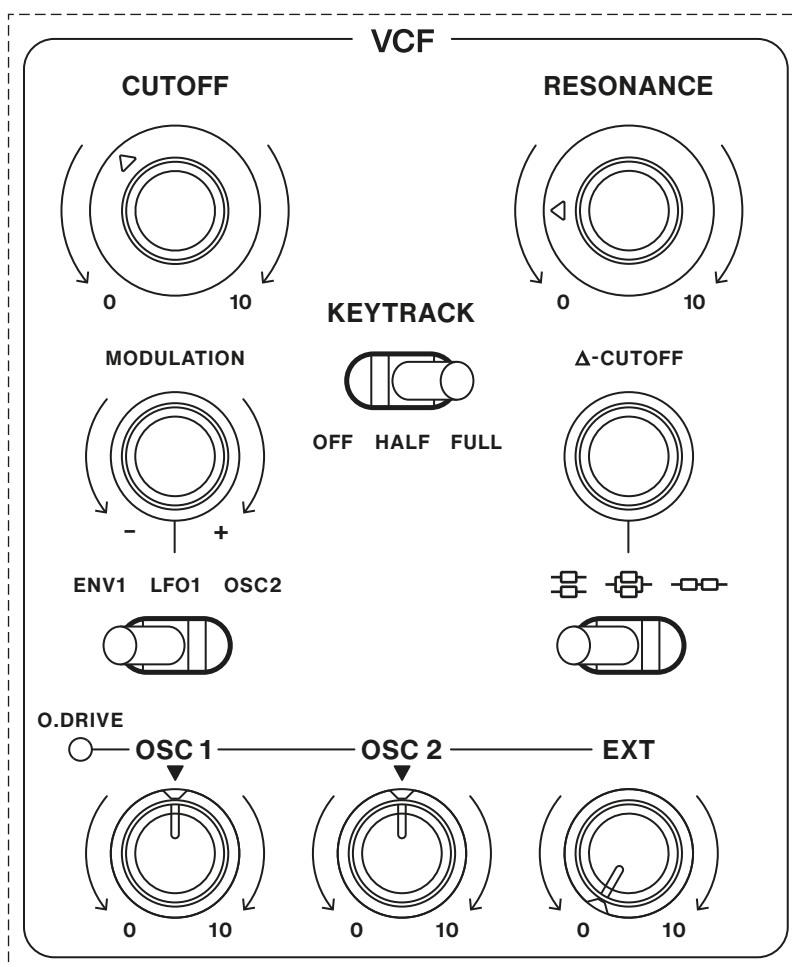

The filter section.

The specially developed filter is a dynamic multi-core stereo filter that can be configured in stereo, parallel or series. Each of the three routings offers you a unique selection of filter types or combinations thereof. In addition, you can choose between two resonance types, which determine whether or not the level of low frequencies drops at increased resonance settings.

The available filter types include low-pass, high-pass, band-pass and all-pass filters, as well as a phase shifter – all with different filter poles that determine their cutoff slope. They can generate both classic, recognisable filter characteristics of well-known vintage instruments as well as bold, experimental or vowel-like sounds. By default, the filter type is set to a 4-pole low-pass filter. For a complete list of available filter types, see page 68.

There are numerous ways to modulate the filter parameters, making the filter section extremely versatile and suitable for a wide range of sounds.

**CUTOFF:** This potentiometer controls the filter cutoff frequency.

**RESONANCE:** This potentiometer controls the amount of filter resonance. When you increase the resonance, the frequencies around the cutoff frequency are emphasised and become more pronounced. All filter types can be driven into self-oscillation by setting the resonance to the highest amount. In this case, the filter will generate a pitch determined by the cutoff frequency and a sound similar to a sine wave.

The **KEYTRACK** toggle switch allows you to determine whether and to what extent the filter cutoff frequency responds to the pitch of the notes played on the keyboard:

- **OFF:** If set to this position, the cutoff frequency of the filter is not affected by the pitch of the notes played on the keyboard.
- **HALF:** If set to this position, the cutoff frequency of the filter follows the pitch of the keyboard in quarter tone steps, making higher notes sound brighter. This corresponds to the typical behaviour of acoustic instruments, so this setting can be useful for creating more natural-sounding timbres.
- **ON:** If set to this position, the cutoff frequency of the filter follows the pitch of the keyboard in semitones as you move up the keyboard. This is useful when using the filter in self-oscillating mode, as the pitch generated by the filter will then follow exactly the intervals you play on the keyboard, allowing you to play the filter like an oscillator.



*The filter is designed to respond to keyboard tracking in a musical way. This in turn determines how far you can open the filter with the **CUTOFF** control. You can use the remaining headroom by modulating the filter's cutoff frequency via the modulation matrix with an envelope or an expression pedal.*

**MODULATION:** This encoder controls the amount of modulation applied to the cutoff frequency.

The toggle switch below the **MODULATION** encoder determines what modulation source is used:

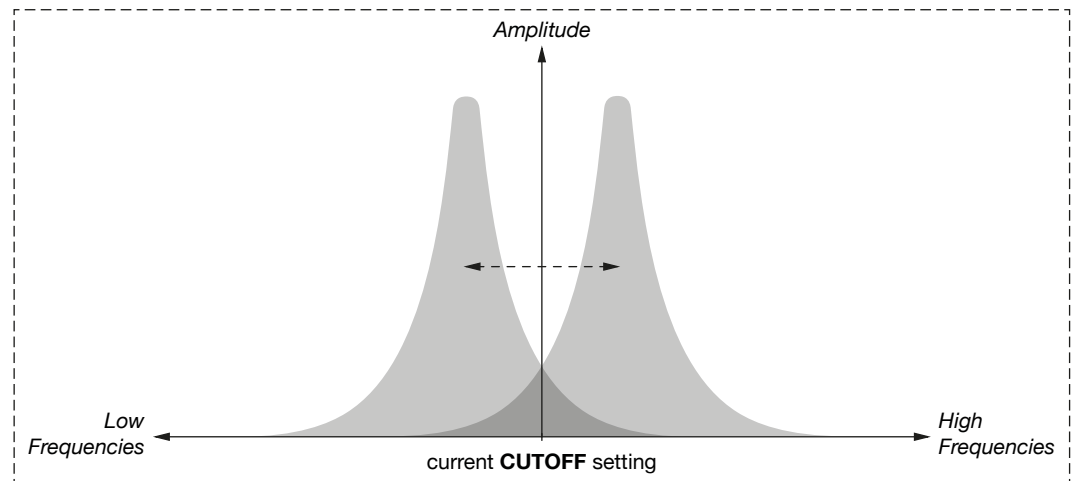

- **ENV 1:** If set to this position, the cutoff frequency is modulated by Envelope 1.
- **LFO 1:** If set to this position, the cutoff frequency is modulated by LFO 1.
- **OSC 2:** If set to this position, the cutoff frequency is modulated by Oscillator 2. The result can range from subtle textures to complex, experimental timbres.

**$\Delta$ -Cutoff:** This filter parameter offsets the cutoff frequency of the two filters used per voice relative to each other, allowing you to adjust the spread of the two filter peaks. The parameter is bipolar. Turning the respective encoder clockwise raises the cutoff frequency of the first filter above that of the second filter. Turning it counterclockwise lowers the cutoff frequency of the first filter below that of the second filter. In the centre position, the cutoff frequencies of both filters are identical.



The two filter peaks, offset by the  $\Delta$ -Cutoff parameter.

The toggle switch below this encoder determines the filter routing:

- : If set to this position, the two filters used per voice are routed in stereo.
- : If set to this position, the two filters used per voice are routed in parallel, with Binaural mode switched off.
- : If set to this position, the two filters used per voice are routed in series, with Binaural mode switched off.

When you move the above toggle switch, further filter parameters appear in the display:

1. Turn encoder **C** to select a filter type or a combination of two filter types for the selected filter routing.
2. Turn encoder **D** to select a resonance type.
  - If set to '1', resonance compensation is applied using a 2-pole band-pass feedback to prevent the level of low frequencies from dropping at increased resonance settings.
  - If set to '2', no resonance compensation is applied. In this case, a 4-pole low-pass filter behaves like the filter of numerous vintage poly synths.



Additional filter parameters can be edited via the filter settings menu.

**OSC 1:** This potentiometer controls the level at which the signal of Oscillator 1 is fed into the filter.

**OSC 2:** This potentiometer controls the level at which the signal of Oscillator 2 is fed into the filter.

**EXT (DMNO 1) / [EXT] (DMNO 2):** On DMNO 1, the potentiometer **EXT** controls the level at which an external audio signal is fed into the filter of the first synthesizer module. In Serial mode, the potentiometer [EXT] on DMNO 2 controls the level at which the output signal from DMNO 1 is fed into the input of the second synthesizer module.



*The levels of the three available audio sources can be overdriven, which is indicated by the **O.DRIVE** LED. The effects can range from sweet, saturated tones to heavily overdriven sounds.*

# LFO 1 (Low Frequency Oscillator 1)

An LFO (Low Frequency Oscillator) is an oscillator that generates frequencies below the range of human hearing. In default mode, LFO 1 can be used to modulate the pitch of the oscillators to create vibrato effects or to modulate the pulse width of the oscillators to create swirling string sounds, for example. LFO 1 can also be set to high frequencies, allowing you to use it as a third oscillator, as a drone, or for modulations at audio rates. Overall, LFO 1 operates in a range from less than 0.1 Hz to over 10 kHz.



*LFO 1 essentially consists of two individual LFOs: one for each of the two Super Voices. If Binaural mode is switched off, each of these LFOs is shared by four voices.*

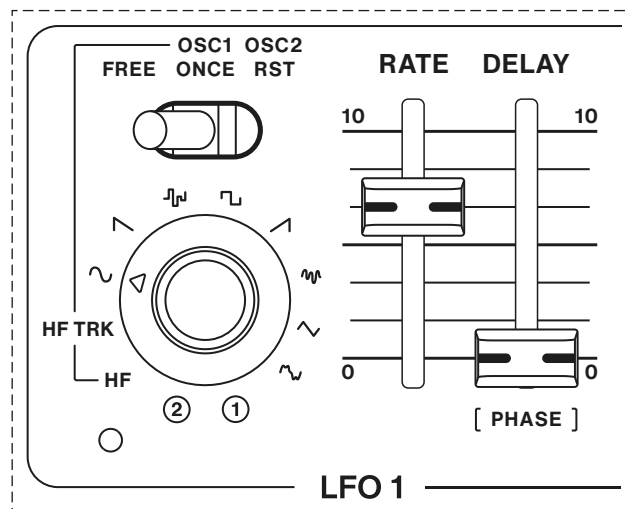

The LFO 1 section.

**WAVEFORM:** Turn this rotary switch to select a waveform for LFO 1 or to set the LFO to one of two high-frequency modes. In low-frequency mode, you can choose between ten different waveforms: sine, sawtooth, sample & hold, square, ramp, noise, triangle, noisy sine, and two user-configurable waveforms that can be loaded into slots **1** and **2**. For more information on the user-configurable waveforms, see page 64.

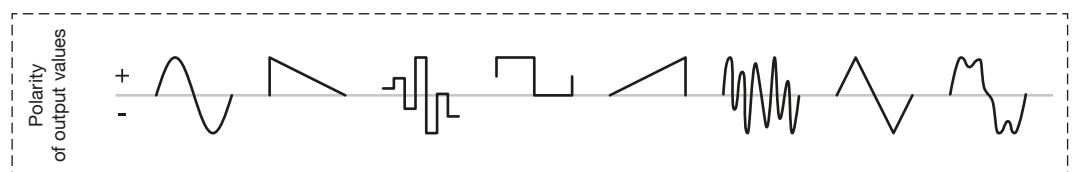

The standard LFO 1 waveforms.

- **Sine** and **triangle** can be used to produce vibrato effects as they

alternates evenly between positive and negative values, while **noisy sine** adds an amount of noise to the modulation. These are bipolar waveforms.

- **Sawtooth, ramp** and **square** generate positive values that enable pulsating sounds or modulations. The square wave can also be used to create trill effects at higher frequencies.
- **Sample & hold** produces random positive or negative values for the duration of one duty cycle. The **noise** waveform does the same at a fixed rate. Both waveforms can be used to create either subtle movements or wild effects. When the rate of LFO 1 is set to the highest frequency, the sample and hold waveform turns into a white noise signal.
- **HF:** Selecting this option activates the high-frequency mode with rates between 20 Hz and 20 kHz. In this mode, LFO 1 can be used either as a drone or as a constant modulation source for audio-range modulations. LFO 1 is set to a sine wave in this mode.
- **HF TRK:** Selecting this option activates high-frequency mode with keyboard tracking. In this mode, LFO 1 can be used either as a third oscillator or as a dynamic modulation source for audio-range modulations. The pitch of LFO 1 can be adjusted to match that of Oscillator 1 and 2 using the **RATE** fader. LFO 1 is set to a sine wave in this mode.

The toggle switch above the **WAVEFORM** rotary switch allows you to choose between three types of LFO modes:

- **FREE:** If set to this position, LFO 1 is free running.
- **ONCE:** If set to this position, LFO1 only runs through one duty cycle when a note is played. In this mode, LFO 1 can be used as a simple envelope, whose shape is defined by the chosen waveform.
- **RST:** If set to this position, the phase of LFO 1 is reset each time a note is played.

When LFO 1 is set to one of the two high-frequency modes, you can use the toggle switch to select one of the following modes:

- **FREE:** If set to this position, LFO 1 acts as a modulation source in high-frequency mode.
- **OSC 1:** If set to this position, the audio signal from LFO 1 in high-frequency mode is routed to the channel of Oscillator 1. In this case, the output signals from LFO 1 and Oscillator 1 are summed.
- **OSC 2:** If set to this position, the audio signal from LFO 1 in high-frequency mode is routed to the channel of Oscillator 2. In this case, the output signals from LFO 1 and Oscillator 2 are summed.

**RATE:** This fader controls the rate of LFO 1. The LED at the bottom left of

the LFO 1 section indicates the rate.



When you activate clock synchronisation for LFO 1 via the modulation settings menu, its rate is synchronised either to the internal clock, as set using the **TEMPO** control, or to an external MIDI clock signal. You can then use the **RATE** fader to set the duty cycle duration of the LFO 1 waveform in clock divisions relative to the internal or external tempo. For more information, see page 62.

**DELAY:** This fader determines the time it takes for the LFO modulation to affect the sound once a note is played.

**PHASE:** In Binaural mode, this secondary function of the **DELAY** fader controls the phase relationship between the left and right channels, i.e. the effect of LFO 1 on the stereo field. With this single control, you can create complex stereo modulations.

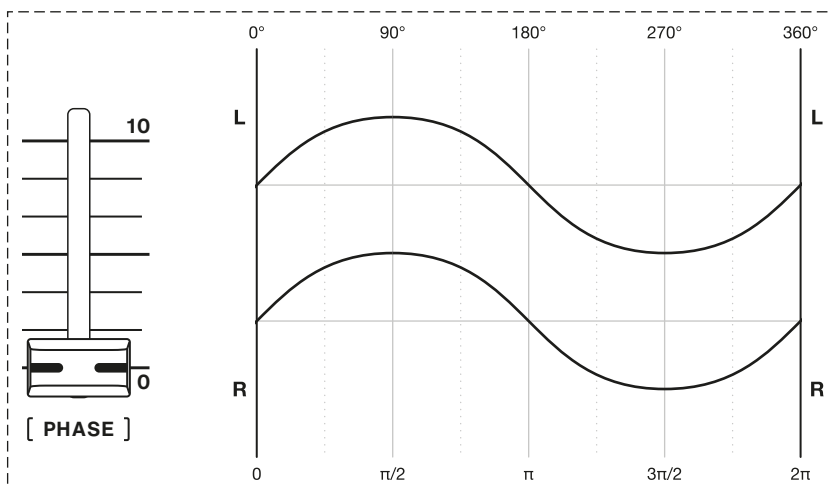

The left-right phase when **PHASE** is set to 0% (0).

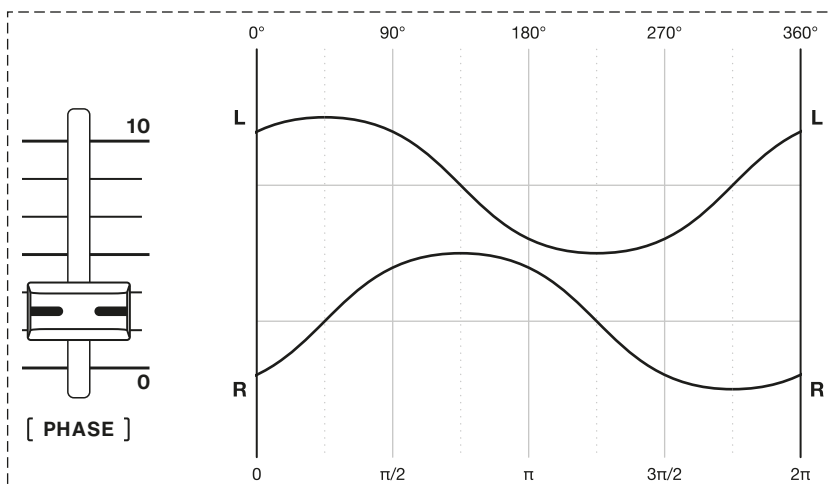

The left-right phase when **PHASE** is set to 25% ( $\pi/2$ ).

NAVIGATION

IMPORTANT SAFETY INSTRUCTIONS

ACKNOWLEDGEMENTS

INTRODUCTION

WHAT IS THE DMNO?

GETTING STARTED

CONNECTIONS

THE SYNTHESIZER  
MODULES: DMNO 1 & 2

THE MIXER

PERFORMANCE CONTROL SECTION

PLAY MODES

VOICE & FILTER SETTINGS

MODULATION SETTINGS

ARPEGGIATOR

EFFECTS & EQUALIZER

GLOBAL SETTINGS

UPDATING THE FIRMWARE

MANAGING FILES

MIDI SPECIFICATIONS

GLOSSARY

SUPPORT INFORMATION

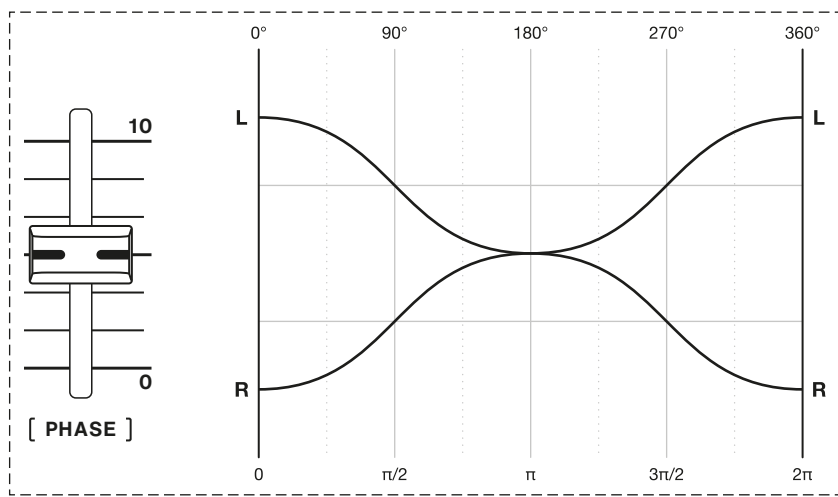

The left-right phase when **PHASE** is set to 50% ( $\pi$ ).

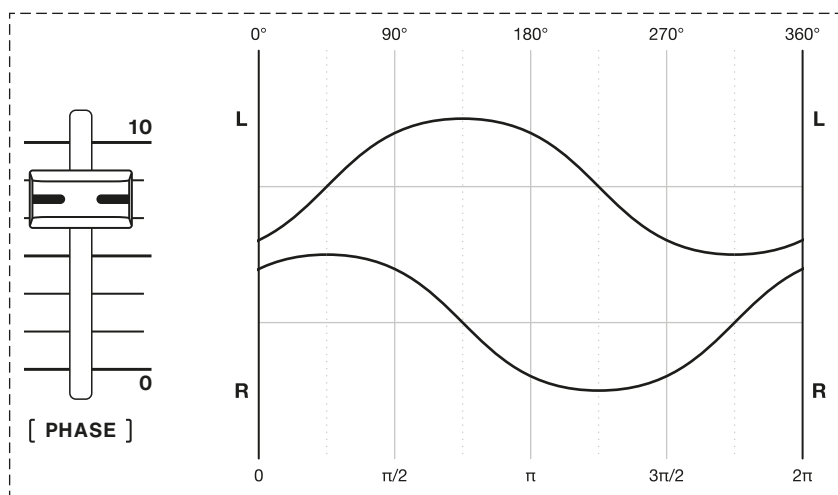

The left-right phase when **PHASE** is set to 75% ( $3\pi/2$ ).

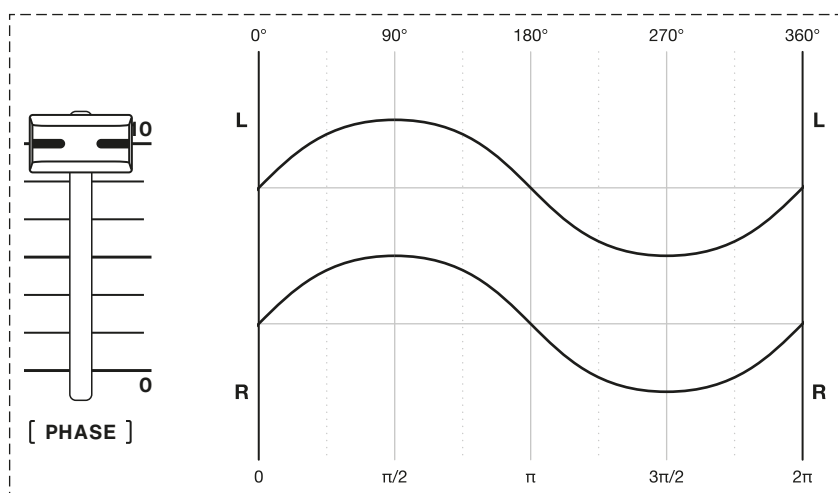

The left-right phase when **PHASE** is set to 100% ( $2\pi$ ).

# Envelopes

With the help of envelope generators, we can determine how a sound develops over time. The resulting envelopes are typically used to control the filter cutoff frequency or the amplifier level to change either the harmonic content or the overall volume of a sound over several stages.

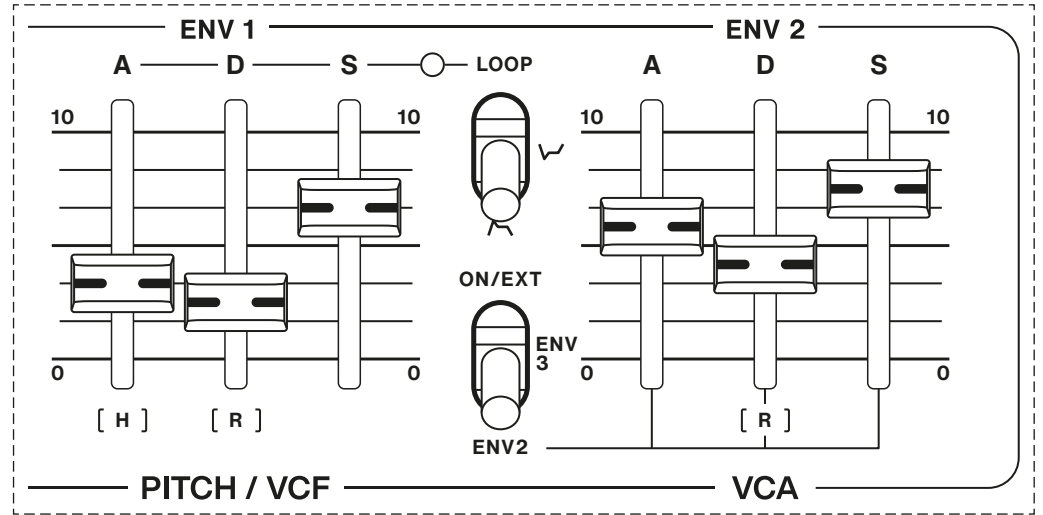

The envelope section.

By default, Envelope 1 is routed to the pitch of the oscillators and the filter cutoff frequency, while Envelope 2 is routed to the VCA level.

Both envelopes consist of four stages, known as attack, decay, sustain and release. In addition, the first envelope features a hold stage, which can be used to delay the start of the attack stage after a note is played.

# ENV 1 (Envelope 1)

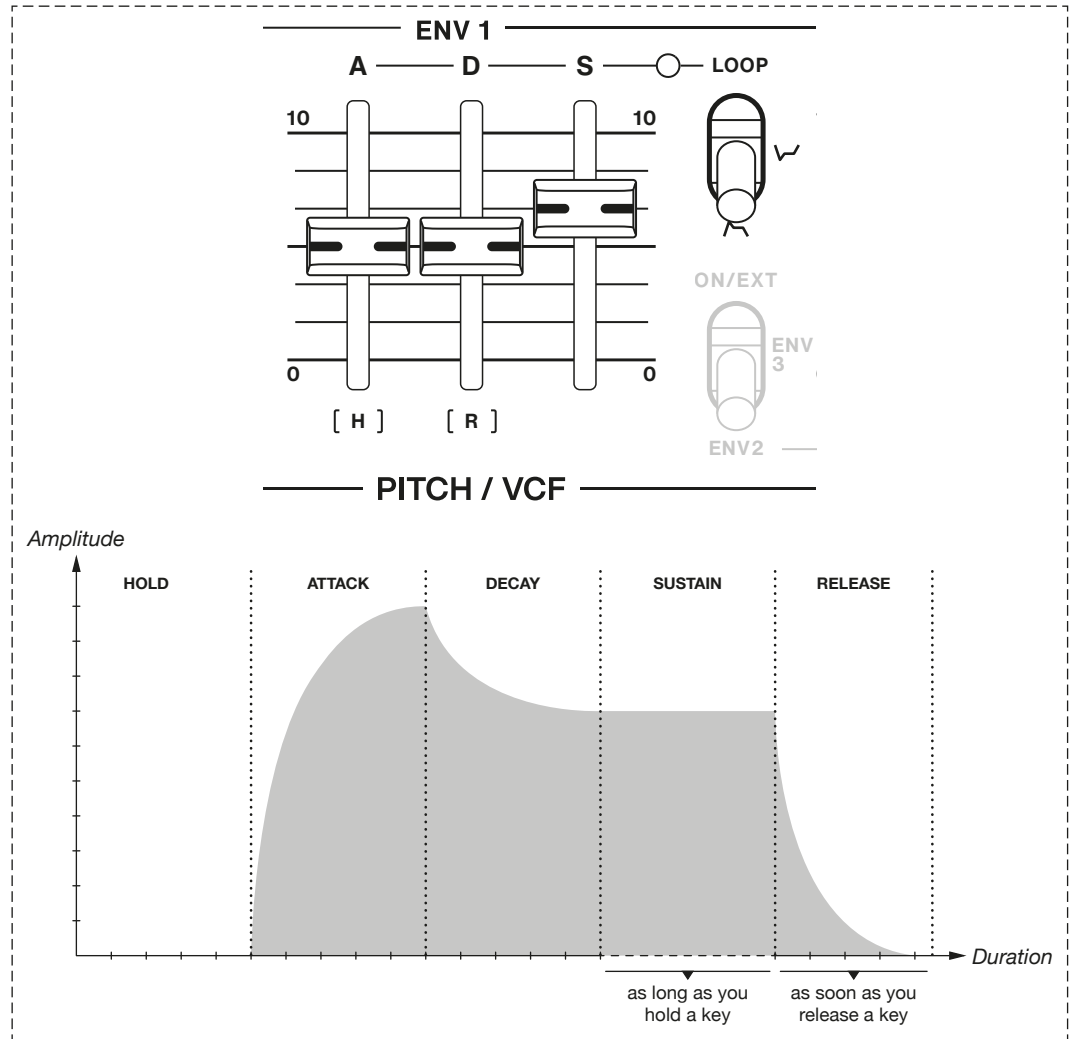

Setting of Envelope 1 and a diagram of the resulting envelope shape.

**H(OLD):** This secondary function of the **A(TTACK)** fader determines how long it takes for the attack stage to begin after a note is played. At its minimum setting, this parameter has no effect, i.e. the envelope then behaves as if it only had four stages (attack, decay, sustain and release).



**A(TTACK):** This fader determines the duration of the envelope's attack stage. The higher the value, the slower the attack time and the longer it takes for the envelope to reach its maximum level.

**D(ECAY):** This fader determines the duration of the envelope's decay stage. The higher the value, the longer it takes for the envelope to fall from its maximum level to the level set by the **S(USTAIN)** fader.

**S(USTAIN):** This fader determines the level at which the envelope is held when you hold a note beyond the decay stage. This is the only envelope parameter that is tied to a level rather than a duration. The duration of the sustain stage depends entirely on how long you hold a note.

**R(ELEASE):** This secondary function of the **D(ECAY)** fader determines the duration of the release stage of the envelope. The higher the value, the slower the release time and the longer it takes for the envelope to decay after a note is released. If the release time is not set individually in Shift mode, it will always be identical to the decay time as set with the **D(ECAY)** fader.

The upper toggle switch allows you to choose between three envelope modes:

- : If set to this position, Envelope 1 is in default mode.
- : If set to this position, the shape of Envelope 1 is inverted. An envelope that rises during its attack stage now falls. The effect on the modulation destination is the opposite of that of Envelope 1 in default mode.
- **LOOP:** If set to this position, Envelope 1 operates in loop mode. Instead of being triggered only once, the attack and decay stages are repeated until you release a note. As soon as you release a note, the release stage is triggered. The speed at which the looped envelope is repeated is indicated by the LED to the left of the **LOOP** label.

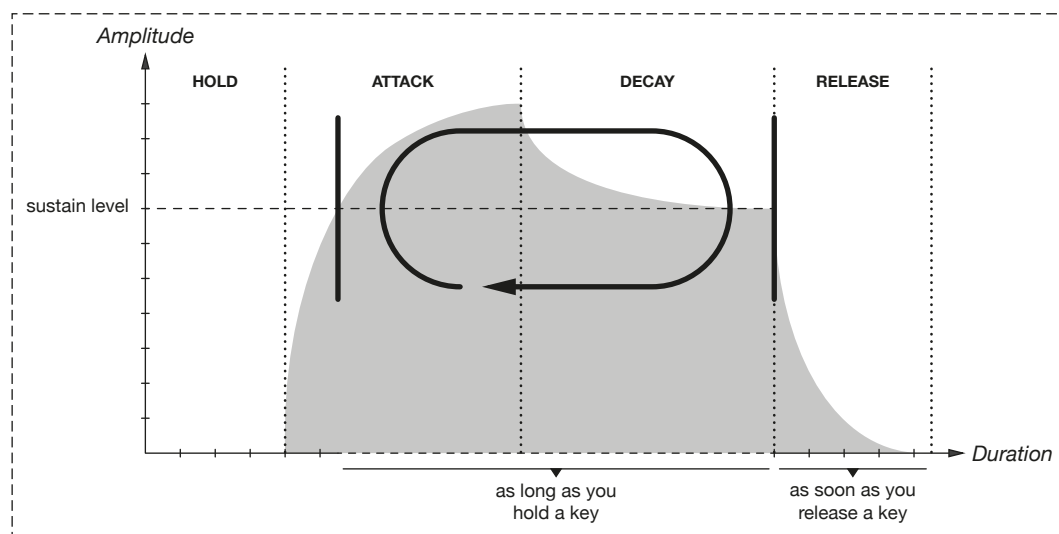

Envelope 1 in loop mode.



*In loop mode, the sustain setting determines the level at which the envelope rises at the beginning of the attack stage and the level to which it falls at the end of the decay stage.*



*When set to loop mode, you can use Envelope 1 as an additional LFO. Low attack and decay settings can generate sonic results similar to frequency modulation.*

## ENV 2 (Envelope 2)

After the audio signal has been shaped by the filter, it is passed on to the voltage-controlled amplifier (VCA). By default, the level generated by the VCA is controlled by Envelope 2, which allows you to control the attack, decay, sustain and release stages. Alternatively, the VCA level can also be controlled by a third envelope or an external audio signal, allowing Envelope 2 to be used for other purposes.

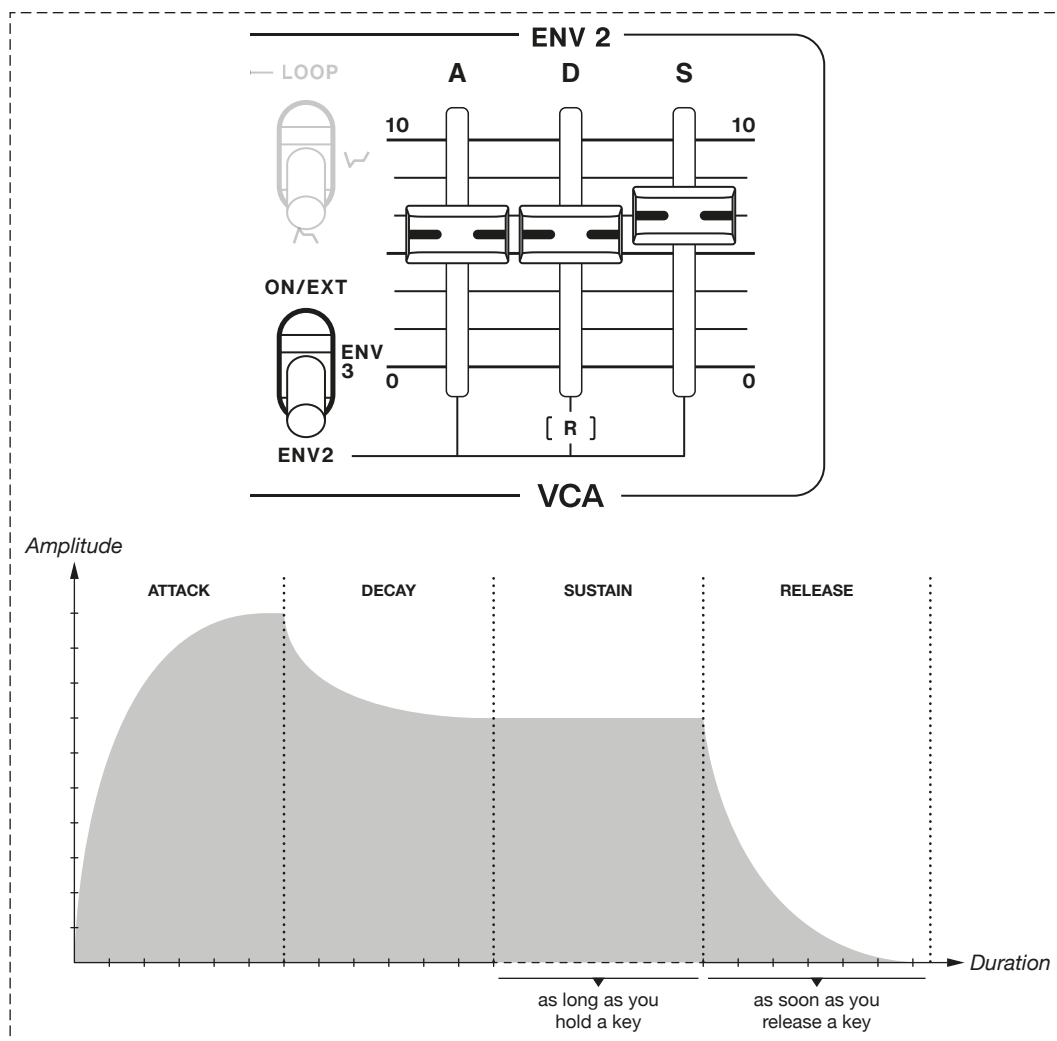

Setting of Envelope 2 and a diagram of the resulting envelope shape.

**A(TTACK):** This fader determines the duration of the envelope’s attack stage. The higher the value, the slower the attack time and the longer it takes for the envelope to reach its maximum level.

**D(ECAY):** This fader determines the duration of the envelope’s decay stage. The higher the value, the longer it takes for the envelope to fall from its maximum level to the level set by the **S(USTAIN)** fader.

**S(USTAIN):** This fader determines the level at which the envelope is held when you hold a note beyond the decay stage. This is the only envelope parameter that is tied to a level rather than a duration. The duration of the sustain stage depends entirely on how long you hold a note.

**R(RELEASE):** This secondary function of the **D(ECAY)** fader determines the duration of the release stage of the envelope. The higher the value, the slower the release time and the longer it takes for the envelope to decay after a note is released. If the release time is not set individually in Shift mode, it will always be identical to the decay time as set with the **D(ECAY)** fader.

The lower toggle switch determines what modulation source is used for the VCA level:

- **ENV 2:** If set to this position, Envelope 2 acts as the modulation source. This is the default mode.
- **ENV 3:** If set to this position, Envelope 3 acts as the modulation source. It has four stages (attack, decay, sustain, release), three modes (normal, inverted, loop) and can be adjusted in the modulation settings menu.
- **ON/EXT:** If set to this position, the VCA remains open, while an external audio signal can be used to control the VCA level, for example for sidechaining effects.

# THE MIXER

The mixer section contains parameters that allow you to balance the output levels and pan the audio signals of both synthesizer modules, set the individual effect send levels, and control the overall volume. While the main output level is controlled by a single parameter, all other parameters are available in pairs – one for each layer or synthesizer module.

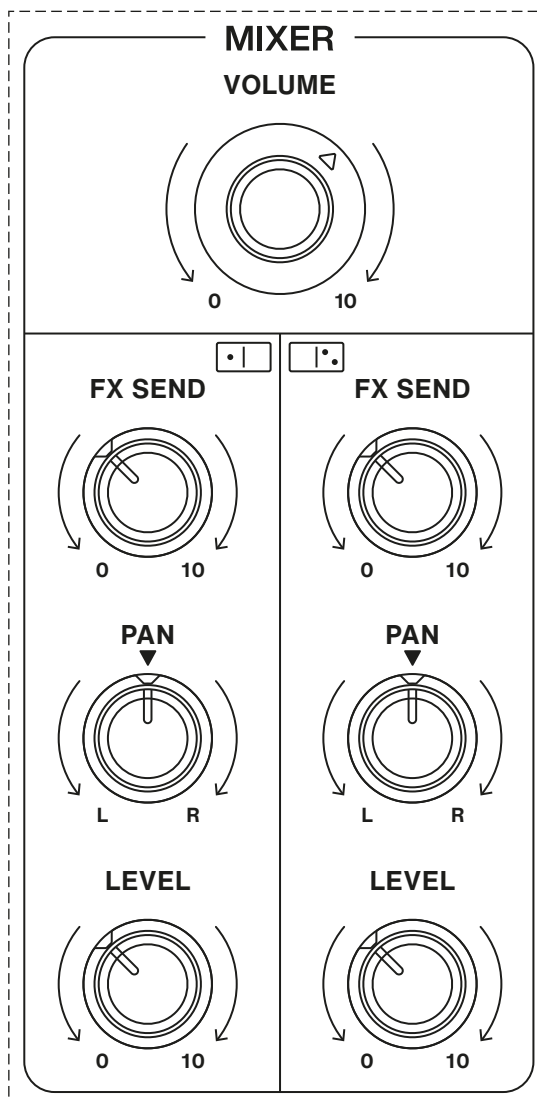

The mixer section.

**VOLUME:** This potentiometer controls the main mix output level of the DMNO as well as the headphone level. To increase the volume, turn the control clockwise. This is the only parameter whose setting is not saved with a performance or patch.

**FX SEND:** This potentiometer controls the level at which the send effects of each layer or synthesizer module (delay and reverb) are mixed in via a parallel signal chain. Higher settings result in a wetter effect mix, while lower settings emphasise the dry signal.

[NAVIGATION](#)

[IMPORTANT SAFETY INSTRUCTIONS](#)

[ACKNOWLEDGEMENTS](#)

[INTRODUCTION](#)

[WHAT IS THE DMNO?](#)

[GETTING STARTED](#)

[CONNECTIONS](#)

[THE SYNTHESIZER MODULES: DMNO 1 & 2](#)

**THE MIXER**

[PERFORMANCE CONTROL SECTION](#)

[PLAY MODES](#)

[VOICE & FILTER SETTINGS](#)

[MODULATION SETTINGS](#)

[ARPEGGIATOR](#)

[EFFECTS & EQUALIZER](#)

[GLOBAL SETTINGS](#)

[UPDATING THE FIRMWARE](#)

[MANAGING FILES](#)

[MIDI SPECIFICATIONS](#)

[GLOSSARY](#)

[SUPPORT INFORMATION](#)

**PAN:** This potentiometer allows you to position the output signal of each layer or synthesizer module within the stereo field. At 12 o'clock, the audio signal is centred. When set to the far left, the audio signal is hard panned to the left. When set to the far right, the audio signal is hard panned to the right.

**LEVEL:** This potentiometer controls the output level of each layer or synthesizer module. To increase the volume, turn the control clockwise. Use the **LEVEL** controls to balance the output levels of both layers when using them simultaneously, for example in Dual or Split mode.

# PERFORMANCE CONTROL SECTION

The performance control section to the left of the keyboard offers a second LFO and contains versatile controls that allow you to add more expression to your sounds while playing. The settings in this section can affect both layers or synthesizer modules either individually or together.

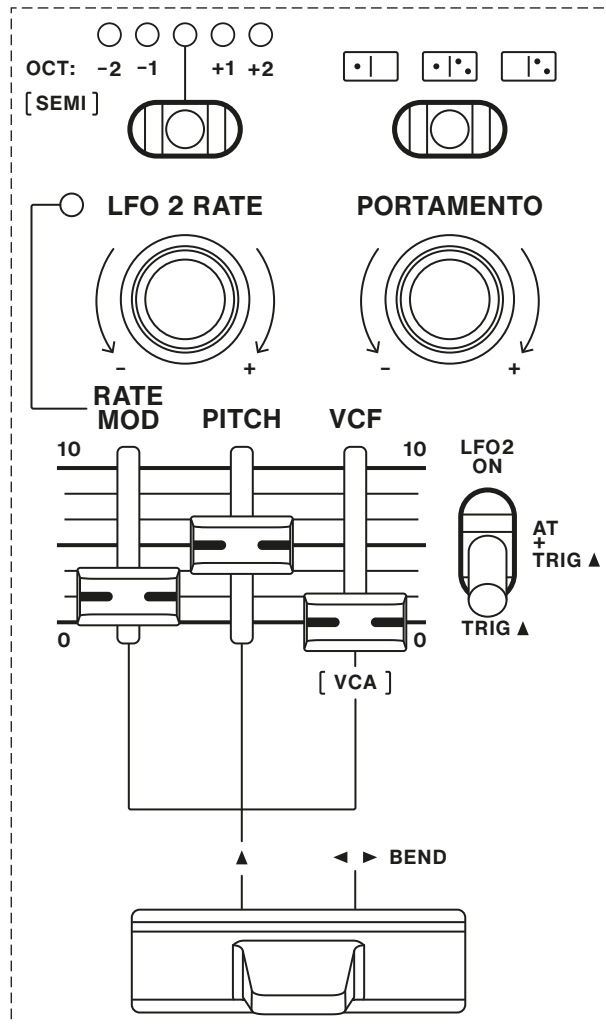

The performance control section.

# The Bender

The bender can be used as a modulation lever to trigger LFO 2, and when moved horizontally, to modulate the pitch of the oscillators and the filter cutoff frequency.

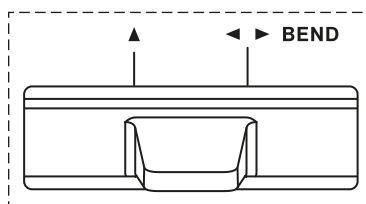

The bender.



*A pressure pad is used to measure the vertically applied force and convert it to a modulation amount. The lever is not designed to be pushed upwards in the same way it can be moved sideways.*

To set the modulation amounts for the bender:

1. Press the **MOD** button to enter the modulation settings menu.
2. Turn encoder **A** to scroll past the freely assignable modulation slots until you reach the next to last page to select the modulation source 'Bender'.
3. Turn encoder **B** to adjust the modulation depth at which the bender controls the pitch of the oscillators. The pitch bend range can be up to +/- 12 semitones.
4. Turn encoder **C** to adjust the modulation depth at which the bender controls the filter cutoff frequency.



Setting the modulation amounts assigned to the bender via the modulation settings menu.

## LFO 2 (Low Frequency Oscillator 2)

The second LFO can be used to modulate the pitch of the oscillators to produce a vibrato effect, to modulate the filter cutoff frequency for periodic harmonic changes, or to modulate the VCA level to create tremolo style effects.

Via the menu for the voice settings (see page 62) you can choose between six different waveforms: triangle, sawtooth, sample & hold, square, ramp and noise. By default, LFO 2 is set to generate a triangle waveform.

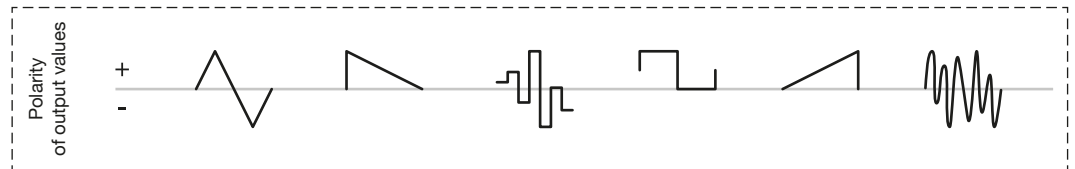

The LFO 2 waveforms.

LFO 2 can be triggered by pushing the bender upwards or by aftertouch. It can also be switched on permanently. The type and depth of the modulation controlled by LFO 2 is determined by the **PITCH** and **VCF/ [VCA]** faders.

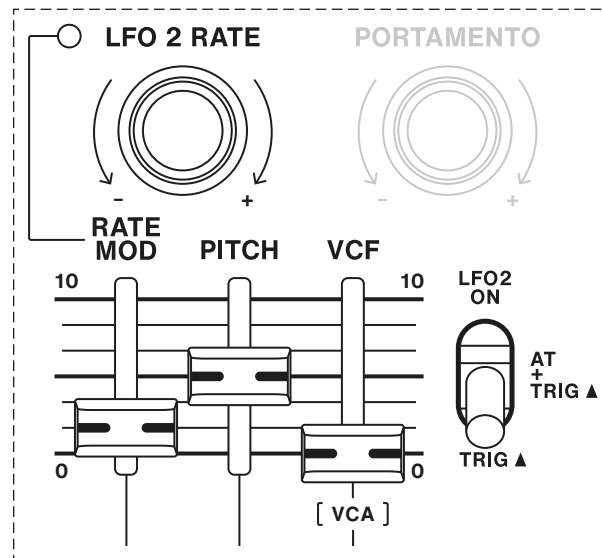

The LFO 2 controls.

**LFO 2 RATE:** This encoder determines the rate of LFO 2. The LED at the top left of this control provides a visual indication of the rate.

**RATE MOD:** This fader determines how much vertical bender movements and/or aftertouch affect the rate of LFO 2. The harder you push the bender or press a key, the more the rate increases.

**PITCH:** This fader controls the amount by which LFO 2 modulates the pitch of the oscillators.

**VCF/[VCA]:** This fader controls the amount by which LFO 2 modulates the filter cutoff frequency. In Shift mode, this fader controls the amount by which LFO 2 modulates the VCA level.

The rightmost toggle switch determines how LFO 2 is triggered:

- **TRIG:** If set to this position, pushing the bender upwards will trigger LFO 2.
- **AT + TRIG:** If set to this position, both aftertouch and pushing the bender upwards will trigger LFO 2. If you use the bender and simultaneously apply pressure to a key, only the gesture with the greater effect on the triggering of LFO 2 controls the modulation depth.
- **LFO 2 ON:** If set to this position, LFO 2 is permanently on. In addition, aftertouch now triggers the same modulations that are controlled by horizontal bender movements.



*When LFO 2 is assigned as a modulation destination, it responds polyphonically. For example, if you use an envelope to modulate the rate of LFO 2, the rate of LFO 2 will be modulated according to the envelope shape each time you play a note. The phase of the per-voice LFOs can be resynchronised by toggling the LFO 2 trigger switch.*

## Portamento

When portamento is enabled, the pitches of the notes you play slide from one note to another. The higher the portamento time, the longer it takes for a note to slide to the pitch of the following note. The portamento time is also determined by the intervals between the played notes. Smaller intervals result in faster pitch slides, while larger intervals result in slower pitch slides. When you change chords, each note slides at a different rate depending on the pitch of each note and the intervals between the triggered voices.

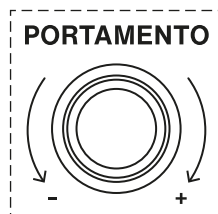

The portamento encoder.

**PORTAMENTO:** This encoder determines the time it takes to slide from one pitch to the next. When set to the leftmost position, portamento will have no effect. When set to the rightmost position, the portamento time for an octave interval is 10 seconds.

## Octave Selector & Transpose Function

The octave selector switch allows you to switch between five octaves. The toggle switch is spring-loaded and enables expressive use while playing notes. The currently selected octave position is indicated by the LEDs above the toggle switch, with **+2** being the highest octave and **-2** the lowest octave.

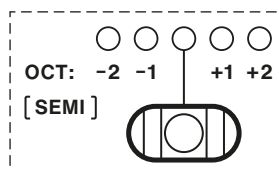

The octave selector switch.

In Shift mode, you can use the octave selector switch to transpose the pitch globally by +/- 12 semitones. As you transpose up, the two LEDs on the right start flashing. As you transpose down, the two LEDs on the left start flashing.

## Module Selection

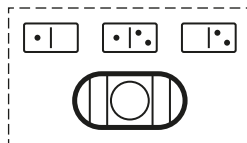

The settings of the performance control section be applied to either or both layers or synthesizer modules.



---

The toggle switch for selecting a layer or synthesizer module.

Use the DMNO selector switch to select the destination for the performance control settings. The following options are available:

-  : If set to this position, control adjustments are applied to DMNO 1.
-  : If set to this position, control adjustments are applied to both synthesizer modules.
-  : If set to this position, control adjustments are applied to DMNO 2.

# PLAY MODES

The various Play modes of the DMNO allow you to determine how the two synthesizer modules interact with each other and in what order their voices are triggered by the notes played on the keyboard or by the arpeggiator.

The available modes range from rather conventional options such as splits and layers to dynamic, unpredictable setups that randomise, chain and reroute the audio signals. By simply turning the **PLAY MODE** encoder, you can transform the entire DMNO system to instantly achieve new behaviours, new sounds or happy accidents.

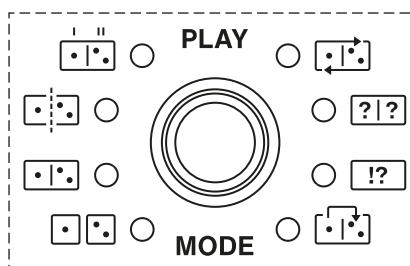

The **PLAY MODE** control.

Below you will find a description of all available play modes in clockwise order from bottom left to bottom right.

 **Single Mode:** Only one synthesizer module is triggered with each note played. Pressing the encoder switches between DMNO 1 and 2, just as when using the two **DMNO** buttons.

 **Dual Mode:** Both synthesizer modules are triggered simultaneously with each note played. Pressing the encoder switches between DMNO 1 and 2, just as when using the two **DMNO** buttons.

 **Split Mode:** The voices of each synthesizer module are assigned to one side of a split point on the keyboard. To set a split point:

1. Press and hold the **PLAY MODE** encoder. The **PLAY MODE** LED starts flashing.
2. Play a note on the keyboard to set the split point. The split point corresponds to the first note of the upper half assigned to DMNO 1.

 **One-Two Mode:** By default, the first note played triggers the voices of the first synthesizer module, while the following notes trigger the voices of the second synthesizer module.

 **Cycle Mode:** By default, the voices of both synthesizer modules are triggered alternately each time a note is played.

NAVIGATION

IMPORTANT SAFETY  
INSTRUCTIONS

ACKNOWLEDGEMENTS

INTRODUCTION

WHAT IS THE DMNO?

GETTING STARTED

CONNECTIONS

THE SYNTHESIZER  
MODULES: DMNO 1 & 2

THE MIXER

PERFORMANCE CONTROL  
SECTION

**PLAY MODES**

VOICE & FILTER SETTINGS

MODULATION SETTINGS

ARPEGGIATOR

EFFECTS & EQUALIZER

GLOBAL SETTINGS

UPDATING THE FIRMWARE

MANAGING FILES



MIDI SPECIFICATIONS

GLOSSARY

SUPPORT INFORMATION

 **Random Mode:** The voices of both synthesizer modules are triggered in random order with each note played. The randomisation settings can be edited in the menu for the voice settings. See page 65 for more details.

 **Chaos Mode:** The voices of both synthesizer modules are triggered in random order with curated note randomisation that can be adjusted in the menu for the voice settings. See page 65 for more details.

 **Series Mode:** In this mode, the output signal of the first synthesizer module is used as a complex oscillator and routed into the oscillator mixer of the second synthesizer module. To adjust the level at which the output signal from DMNO 1 is fed into DMNO 2 use potentiometer  in the mixer section of DMNO 2's filter.

# VOICE & FILTER SETTINGS

In the menus for the voice and filter settings, you can set a voice assignment mode, select additional waveforms for both oscillators and LFO 1, choose which filter types and combinations thereof are used for each of the three filter routing modes, and access further advanced features.

Press the **VOICE/VCF** button to switch between the respective menus. Turn encoder **A** to navigate through the pages of each menu.

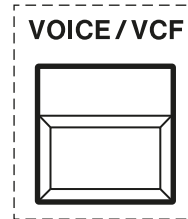

The **VOICE/VCF** button.



The display indicating which menu you have selected.

# Voice Assignment

On the ‘Voice’ page, you can specify how the voices of each layer or synthesizer module are distributed when a note is played, set a unison mode and switch Binaural mode on or off.



The ‘Voice’ page.

To edit the voice assignment:

1. Turn encoder **A** to navigate to the ‘Voice’ page.
2. Turn encoder **B** to select a voice assignment mode.
  - If set to ‘Poly 1’, full polyphony is enabled per layer or synthesizer module. When new notes are played, the release stages of all notes overlap, enabling smooth transitions between notes.
  - If set to ‘Solo’, only one note can be played at a time. Each time a note is played, the envelopes are retriggered.
  - If set to ‘Legato’, only one note can be played at a time. When playing legato, the envelopes are not retriggered.
  - If set to ‘Unison’, the voices are stacked for massive sounds.
  - If set to ‘Poly 2’, full polyphony is enabled per layer or synthesizer module. The release stage of overlapping notes is curtailed in this mode.
3. If you selected ‘Unison’, set the unison mode using encoder **C**.
  - If set to ‘Level 1’, all available voices are stacked.
  - If set to ‘Level 2’, all available voices are stacked and detuned.
  - If set to ‘Octave’, all available voices are stacked as an octave.
  - If set to ‘Fifth’, all available voices are stacked as a fifth.
  - If set to ‘Major’, all available voices are stacked as a major chord.
4. Press or turn encoder **D** to switch Binaural mode on or off. When Binaural mode is switched off, 4 voices are available per layer or synthesizer module. When you switch on Binaural mode, these 4 available voices are combined into 2 ‘Super voices’.

## ENV 3 Parameters

On the ‘ENV 3’ page, you can adjust the Envelope 3 parameters. The auxiliary envelope features four stages (attack, decay, sustain, release) as well as three modes.

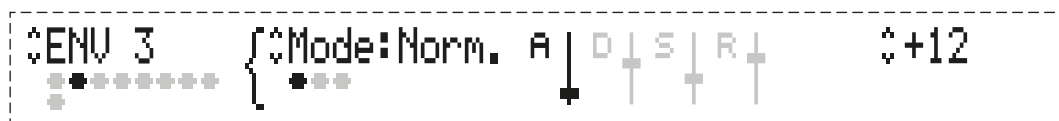

The ‘ENV 3’ page.

To edit the Envelope 3 parameters:

1. Turn encoder **A** to navigate to the ‘ENV 3’ page.
2. Turn encoder **B** to select an envelope mode.
  - If set to ‘Norm.’, Envelope 3 is in default mode.
  - If set to ‘Inv.’, the shape of Envelope 3 is inverted. An envelope that rises during its attack stage now falls. The effect on the modulation destination is the opposite of that of Envelope 3 in default mode.
  - If set to ‘Loop’, Envelope 3 operates in loop mode. Instead of being triggered only once, the attack and decay stages are repeated until you release a note. As soon as you release a note, the release stage is triggered.
3. Turn encoder **C** to select the envelope stage you wish to edit (attack, decay, sustain or release).
4. Turn encoder **D** to edit the selected envelope stage.

## LFO 2 Parameters

On the ‘LFO 2’ page, you can adjust additional LFO 2 parameters that allow you to change the waveform and set the delay with which the LFO affects its modulation destination.

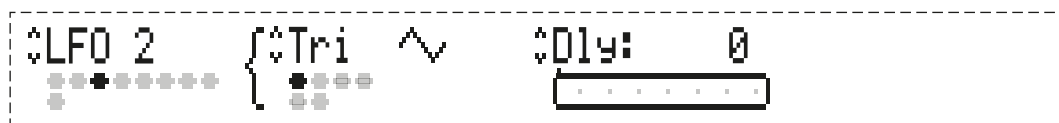

The ‘LFO 2’ page.

To edit the LFO 2 parameters:

1. Turn encoder **A** to navigate to the ‘LFO 2’ page.
2. Turn encoder **B** to change the LFO 2 waveform. You can choose between six different waveforms: triangle, sawtooth, sample & hold, square, ramp and noise.
3. Turn encoder **C** to edit the delay parameter for LFO 2 to determine the time it takes for the LFO modulation to affect the sound once a note is played.

# Voice Variation

On the ‘Voice Variation’ page, you can set the degree of randomness applied to various parameters, including the pitch of oscillators, filters, and envelopes, to mimic the characteristics of unstable vintage synthesizers. In addition, you can set how far the voices are panned in the stereo field when binaural mode is switched off.



The ‘Voice Variation’ page.

To add voice variation:

1. Turn encoder **A** to navigate to the ‘Voice Variation’ page.
2. Turn encoder **C** to set the degree of randomness applied to various parameters.
3. Turn encoder **D** to set the width of the voice panning. At zero, all voices are centred. At the highest setting, all voices are alternately hard panned between the left and right channels.



*When Binaural mode is off, you can also use the **DELAY** fader in the LFO 1 section in Shift mode to adjust the voice panning.*

## User-Configurable Waveforms

On the pages ‘OSC1 Wv’, ‘OSC2 Wv’ and ‘LFO1 Wv’, you can select additional waveforms for Oscillator 1, Oscillator 2 and LFO 1. The additional waveforms are be loaded into the available slots from a pool of 32 alternative waveforms stored on the disk.

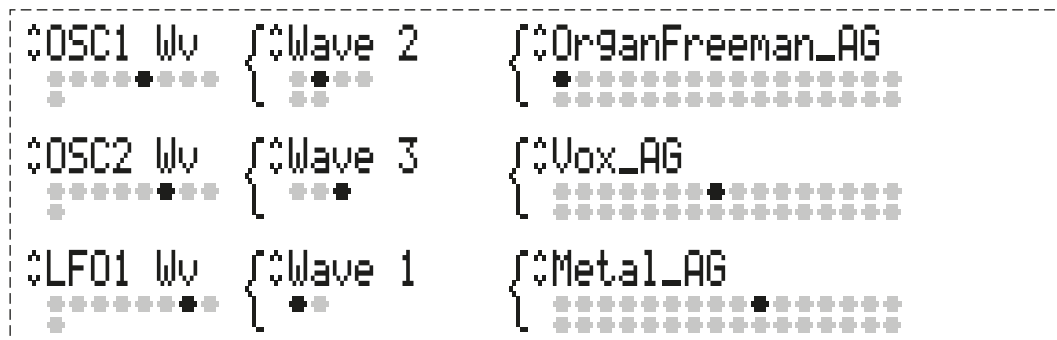

The pages for loading additional waveforms.

To load additional waveforms:

1. Turn encoder **A** to select Oscillator 1, Oscillator 2 or LFO 1.
2. Turn encoder **B** to select a slot. You can choose between slots **1-6** for Oscillator 1, slots **1-3** for Oscillator 2, and slots **1** and **2** for LFO 1.
3. Turn encoder **C** to select the desired waveform.
4. Press encoder **D** to load the desired waveform into the selected slot.



*The user-configurable waveforms are not saved per patch.*

# Randomisation Settings

On the ‘Rndmzr!?’ page, you can set probabilities for note intervals and the triggered synthesizer modules. The corresponding settings affect how and at what intervals notes are triggered in the various Play modes.

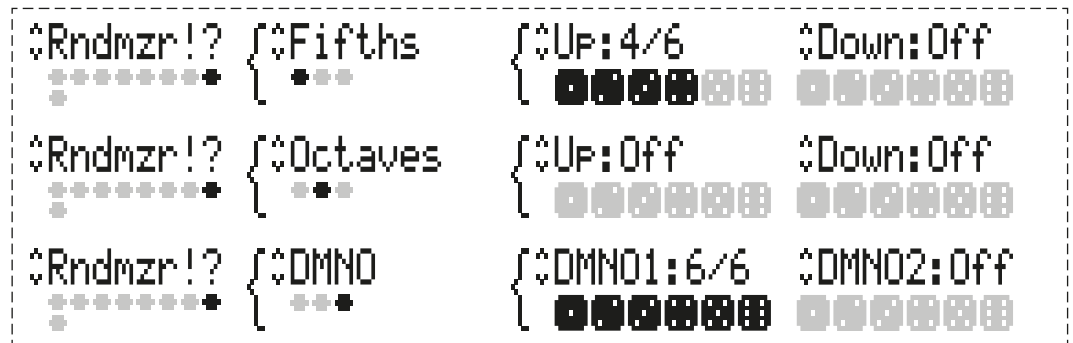

The ‘Rndmzr!?’ options.

To edit the randomisation settings:

1. Turn encoder **A** to navigate to the ‘Rndmzr!?’ page.
2. Turn encoder **B** to select a parameter to be randomised.
  - Select ‘Fifths’ to display the probability with which notes are played a fifth up or down.
  - Select ‘Octave’ to display the probability with which notes are played an octave up or down.
  - Select ‘DMNO’ to display the probability with which played notes trigger the voices of DMNO 1 or DMNO 2.
3. Turn encoder **C** to adjust the probability of notes being played a fifth and an octave up, as well as the probability of played notes triggering the voices of DMNO 1.
4. Turn encoder **D** to adjust the probability of notes being played a fifth and an octave down, as well as the probability of played notes triggering the voices of DMNO 2.

 *Randomised DMNO settings are only available in the Play modes Single, Chaos and Random.*

 *The probabilities with which played notes trigger DMNO 1 and DMNO 2 are shared between the two synthesiser modules. If the probability for one DMNO is increased, the probability for the other DMNO is reduced.*

# Envelope Follower

On the ‘E. Follow’ page, you can adjust the parameters for the envelope follower, including the attack and release stages as well as the threshold.



The ‘E. Follow’ page.

To edit the parameters for the envelope follower:

1. Turn encoder **A** to navigate to the ‘E. Follow’ page.
2. Turn encoder **B** to set the duration of the envelope follower’s attack stage. Use this parameter to fine-tune the response of the envelope follower, for example, if you want to use an external audio signal for modulation purposes.
3. Turn encoder **C** to set the duration of the envelope follower’s release stage. Use this parameter to fine-tune the response of the envelope follower, for example, if you want to use an external audio signal for modulation purposes.
4. Turn encoder **D** to set the threshold at which an external audio signal triggers the DMNO’s envelope follower.

## Filter Settings

On the ‘VCF Path’ page, you can specify the filter routing, various filter types or combinations thereof, and choose between two resonance types. This page is also displayed when you toggle the filter routing switch in the filter section of each synthesizer module.

The various filter types and their combinations can be selected from a curated set that differs for each filter routing mode. The available filter types include low-pass (LP), high-pass (HP), band-pass (BP) and all-pass filters (AP), as well as a phase shifter (PS) – all with different filter poles that determine their cutoff slope: 1-pole (1P), 2-pole (2P), 3-pole (3P) and 4-pole (4P).

The filter types are abbreviated as follows: ‘4PLP’ stands for 4-pole low-pass filter, ‘3PHP’ for 3-pole high-pass filter, ‘2PBP’ for 2-pole band-pass filter, etc.



The ‘VCF Path’ page.

To edit the filter settings:

1. Turn encoder **A** to navigate to the ‘VCF Path’ page.
2. Turn encoder **B** to select a filter routing.
  - If set to ‘Stereo’ (default), Binaural mode is activated.
  - If set to ‘Parallel’ or ‘Series’, Binaural mode is switched off.
3. Turn encoder **C** to select a filter type or a combination of two filter types for the selected filter routing.
4. Turn encoder **D** to select a resonance type.
  - If set to ‘1’, resonance compensation is applied using a 2-pole band-pass feedback to prevent the level of low frequencies from dropping at increased resonance settings.
  - If set to ‘2’, no resonance compensation is applied. In this case, a 4-pole low-pass filter behaves like the filter of numerous vintage poly synths.

The following filter and resonance types are available for each filter routing option:

Stereo Filter Types	Resonance Type
4PLP	1, 2
2PLP	1, 2
1PLP	1, 2
3PHP	
2PHP	
1PHP	
4PBP	
2PBP	
4PAP	
4PS	
1PLP + 3PHP	
3PLP + 1PHP	

Parallel Filter Types	Resonance Type
2PLP + 2PLP	1, 2
1PLP + 1PLP	1, 2
2PBP + 2PBP	
4PBP + 4PBP	

Series Filter Types	Resonance Type
4PS -> 1PLP	
4PS -> 2PLP	
4PS -> 1HP	
4PS -> 4PS	
1PLP -> 1PLP	
1PLP -> 1PHP	



*The options listed above may be subject to change with future firmware versions.*

## Filter Modulations

On the ‘VCF Mod’ page, you can adjust the amount of modulation applied to the filter cutoff frequency. This page is also displayed when you use the **MODULATION** encoder or the corresponding toggle switch in the filter section of each synthesiser module.



The ‘VCF Mod’ page. Non-active modulation sources are greyed out.

To edit the modulation amounts applied to the filter cutoff frequency:

1. Turn encoder **A** to navigate to the ‘VCF Mod’ page.
2. Use the toggle switch below the **MODULATION** encoder to switch between the active modulation sources.
3. Turn encoder **B** to adjust the modulation depth at which Envelope 1 controls the filter cutoff frequency.
4. Turn encoder **C** to adjust the modulation depth at which LFO 1 controls the filter cutoff frequency.
5. Turn encoder **D** to adjust the modulation depth at which Oscillator 2 controls the filter cutoff frequency.

# MODULATION SETTINGS

---

The top panel of both synthesizer modules and the performance control section offer numerous options for assigning different modulation sources to different modulation destinations. To go beyond these options, you can use the modulation settings menu. Here you can access the modulation matrix for each layer, adjust parameters for modulation sources that are not available on the front panel, and set modulation amounts for hard-wired modulation routings.

Press the **MOD** button to access the modulation settings menu. Turn encoder **A** to navigate through the modulation slots and pages of this menu.

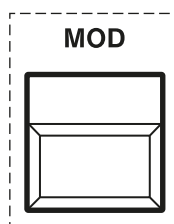

---

The **MOD** button.

## Using the Modulation Matrix

The modulation matrix provides you with six freely assignable modulation slots you can use to further shape your sounds.



One of seven available modulation slots in the modulation matrix.

To create a modulation routing:

1. Turn encoder **A** to select a modulation slot (1-7).
2. Turn encoder **B** to select a modulation source.
3. Turn encoder **C** to select a modulation destination.
4. Turn encoder **D** to set the modulation amount.



*Press encoder **D** to compare the edited modulation amount to the saved modulation amount.*

To clear all modulation routings from a modulation source:

1. Press encoder **B**. The display prompts you to confirm.
2. Press either encoder **C** to confirm or encoder **D** to cancel the procedure.

To clear all modulation routings to a modulation destination:

1. Press encoder **C**. The display prompts you to confirm.
2. Press either encoder **C** to confirm or encoder **D** to cancel the procedure.

To clear all modulation routings:

1. Press encoder **A**. The display prompts you to confirm.
2. Press either encoder **C** to confirm or encoder **D** to cancel the procedure.

## Modulation Sources

The following modulation sources are available:

Modulation Source		Modulation Source	
1	Oscillator 2	6	Velocity
2	LFO 1	7	Aftertouch
3	LFO 2	8	Expression Pedal
4	Envelope 1	9	Envelope Follower
5	Envelope 2	10	Note Number



*The options listed above may be subject to change with future firmware versions.*

## Modulation Destinations

The following modulation destinations are available:

Modulation Destination		Modulation Destination	
1	LFO 1 Rate	9	Oscillator 1 Mix
2	Filter Cutoff Frequency	10	Oscillator 2 Mix
3	$\Delta$ -Cutoff	11	Filter Resonance
4	Envelope 1 > Filter Cutoff Frequency	12	Envelope 1 Decay
5	Envelope 1 Depth	13	Delay Time
6	LFO 1 Depth	14	VCA Level
7	Oscillator 2 > Oscillator 1	15	Envelope 1 Attack
8	Oscillator 1 Wave		



*The options listed above may be subject to change with future firmware versions.*

## Predefined Modulation Routings

If you scroll past the pages for the modulation slots, you will reach the pages for predefined modulation routings. These allow you to edit the modulation amounts assigned to the bender or velocity.



The 'Bender' page.

To set the modulation amounts for the bender:

1. Turn encoder **A** to navigate to the 'Bender' page.
2. Turn encoder **B** to adjust the modulation depth at which the bender controls the pitch of the oscillators. The pitch bend range can be up to +/- 12 semitones.
3. Turn encoder **C** to adjust the modulation depth at which the bender controls the filter cutoff frequency.

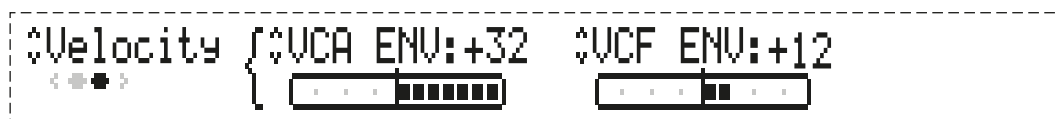

The 'Velocity' page.

To edit the modulation amounts controlled by velocity:

1. Turn encoder **A** to navigate to the 'Velocity' page.
2. Turn encoder **B** to adjust the modulation depth at which velocity controls the VCA envelope level.
3. Turn encoder **C** to adjust the modulation depth at which velocity controls the filter envelope level.

# ARPEGGIATOR

The DMNO features a flexible and easy to use arpeggiator. In combination with the various Play modes and by mixing different arpeggios, for example in Dual or Split mode, complex rhythm patterns can be created.

## Arpeggiator Controls

When you switch on the arpeggiator and play a chord, an arpeggio is generated based on the notes you are holding. There are many ways to change the way the currently held chord is arpeggiated. Each layer or synthesizer module can be triggered by its own arpeggio.

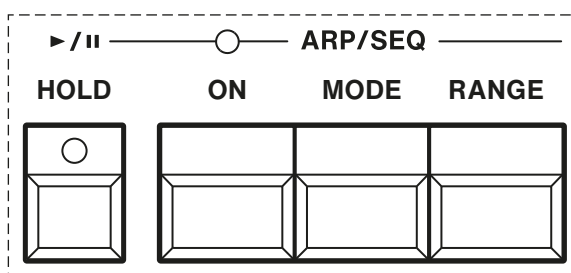

The front panel controls for the arpeggiator.

**HOLD:** When you activate the hold function for one of the synthesizer modules while the arpeggiator is switched on, you can release all keys after playing a note or a chord. The arpeggio that triggers the respective module will then continue to play. When you then release all keys and play a new chord, a new arpeggio is generated each time.

When this button is switched on while the arpeggiator is off, the notes triggering the currently selected synthesizer module will continue to be sustained even after all keys have been released.

**ON:** Press this button to switch the arpeggiator on or off.

**MODE:** Pressing this button reveals additional arpeggiator parameters in the display, allowing you to choose between seven different playback modes. These can be selected either by repeatedly pressing the **MODE** button or using encoder **B**.

- If set to 'Up', the arpeggio runs from the lowest to the highest note.
- If set to 'Down', the arpeggio runs from the highest to the lowest note.
- If set to 'Up+Down', the arpeggio runs from the lowest to the highest note and back to the lowest note.
- If set to 'Random', notes are arpeggiated in random order.

**RANGE:** Pressing this button reveals additional arpeggiator parameters in the display, allowing you to choose between four different octave ranges. These can be selected either by repeatedly pressing the **RANGE** button or using encoder **C**.

- If set to '1', the arpeggio consists of the notes you actually hold on the keyboard.
- If set to '2', the arpeggio spans a range of two octaves.
- If set to '3', the arpeggio spans a range of three octaves.
- If set to '4', the arpeggio spans a range of four octaves.

# Arpeggiator Settings

In the arpeggiator menu, you can adjust the parameters mentioned above, set the clock division and swing intensity, and access further advanced options.

Press the **ARP/SEQ** button to access the arpeggiator menu. Turn encoder **A** to navigate through the pages of this menu.

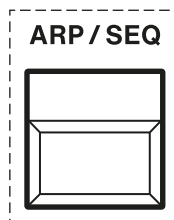

The **ARP/SEQ** button.

## General Settings

On the 'Arp Mode' page, you can set the playback mode, octave range and clock division.



The 'Arp Mode' page.

To edit the general arpeggiator settings:

1. Turn encoder **A** to navigate to the 'Arp Mode' page.
2. Turn encoder **B** or press the **MODE** button repeatedly to select a voice assignment mode.
  - If set to 'Up', the arpeggio runs from the lowest to the highest note.
  - If set to 'Down', the arpeggio runs from the highest to the lowest note.
  - If set to 'Up+Down', the arpeggio runs from the lowest to the highest note and back to the lowest note.
  - If set to 'Random', notes are arpeggiated in random order.

3. Turn encoder **C** or press the **RANGE** button repeatedly to select an octave range.
  - If set to '1', the arpeggio consists of the notes you actually hold on the keyboard.
  - If set to '2', the arpeggio spans a range of two octaves.
  - If set to '3', the arpeggio spans a range of three octaves.
  - If set to '4', the arpeggio spans a range of four octaves.
4. Turn encoder **D** to set a clock division for the arpeggiator.

The following clock divisions are available:

Setting	Clock Division	Tempo
1/1	Whole note	BPM x 1/4
1/2	Half note	BPM x 1/2
1/4	Quarter note	BPM
1/8	Eighth note	BPM x 2
1/16	Sixteenth note	BPM x 4
1/32	Thirty-second note	BPM x 8
1/4T	Quarter note triplet	BPM x 1 1/2
1/8T	Eighth note triplet	BPM x 3

## MIDI Settings

On the 'Arp MIDI' page, you can configure the MIDI settings relevant for the arpeggiator.

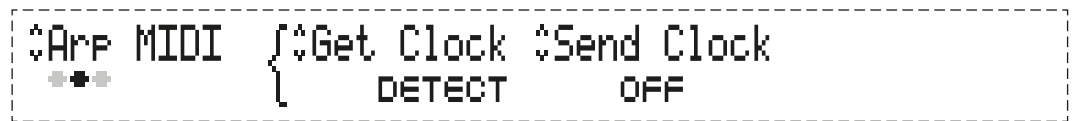

The 'Arp MIDI' page.

To configure the MIDI settings:

1. Turn encoder **A** to navigate to the 'Arp MIDI' page.
2. Press encoder **B** to switch clock detection on or off.
  - If set to 'Local', an external clock signal is ignored.
  - If set to 'Detect', an external clock signal is automatically detected when received.
3. Press encoder **C** to switch clock transmission on or off.
  - If set to 'Off', the DMNO does not send a clock signal via MIDI.
  - If set to 'On', the DMNO sends a clock signal via MIDI.

## Swing Settings

On the 'Arp Swing' page, you can adjust the swing setting.

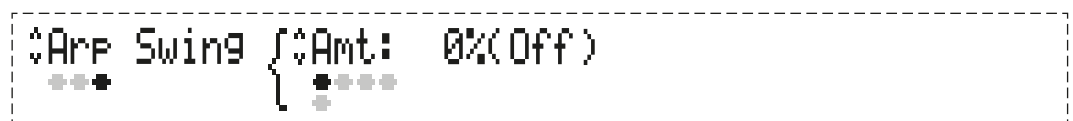

The 'Arp Swing' page.

To edit the swing setting:

1. Turn encoder **A** to navigate to the 'Arp Swing' page.
2. Turn encoder **B** to set the swing amount in increments of 25% from 0% to 100%.

# Clock Controls

In the tempo section, you can set the clock rate for the arpeggiator.

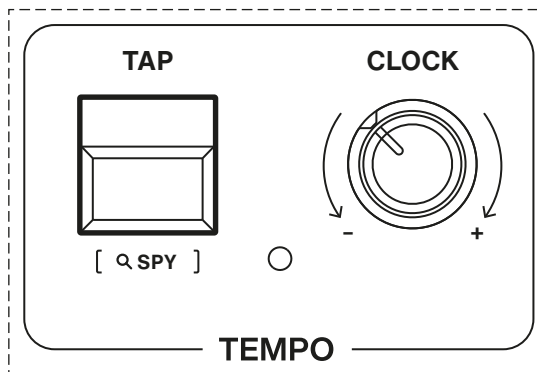

The tempo section.

**TAP:** Tap this button at least four times in succession at the desired tempo to set the clock rate for the arpeggiator. The clock LED will then flash at the set tempo.

**CLOCK:** This potentiometer allows you to set the clock rate for the arpeggiator. The current tempo is indicated by the clock LED.



*When the arpeggiator is synchronised to an external MIDI clock source, the **TAP** and **TEMPO** controls have no effect. In this case, use the clock division parameter in the arpeggiator menu to set the playback speed in clock divisions relative to the external clock rate.*

# EFFECTS & EQUALIZER

The DMNO features a 32-bit DSP-based effects engine that you can use to add the finishing touches to your sounds. There are two types of effects: insert effects and send effects.

Insert effects are connected in series with the output signals of each synthesizer module. These include a multimode distortion, a chorus and a 3-band EQ with a bandwidth parameter for the mid-band.

Send effects are mixed in via a parallel signal chain using the **FX SEND** potentiometer in the mixer section. These include a multimode delay and a reverb.

Each of the available effects can be edited in the menus for the effects and equalizer settings.

Press the **FX/EQ** button to switch between the menus for distortion, chorus, equalizer and send effects. Turn encoder **A** to navigate through the pages of each menu, where possible.

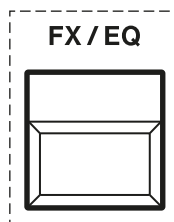

The **FX/EQ** button.



The display indicating which menu is selected.

# Drive

In the ‘Driver’ menu, you can select a distortion mode and adjust the settings for tone and drive as well as the wet/dry balance.

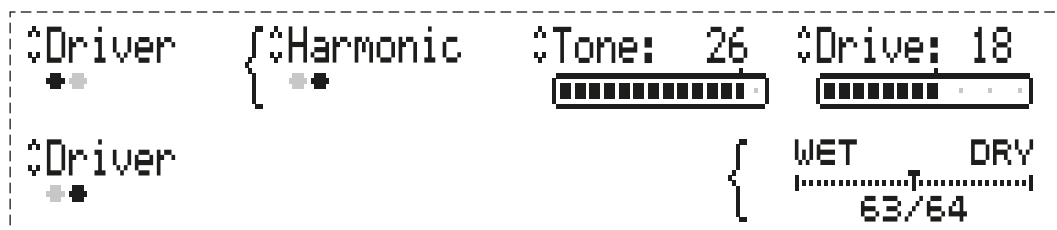

The pages for the ‘Driver’ menu.

To edit the drive parameters:

1. Turn encoder **A** to navigate to the first ‘Driver’ page.
2. Turn or press encoder **B** to switch the distortion on or off.
3. Turn encoder **C** to adjust the tone. Lower settings result in a darker sound, while higher settings emphasise the high frequencies.
4. Turn encoder **D** to adjust the drive level. Lower settings result in a subtle effect, while higher settings can be used for aggressive sounds.
5. Turn encoder **A** to navigate to the second ‘Driver’ page.
6. Turn encoder **D** to adjust the wet/dry balance. This parameter determines how much the distorted signal is mixed with the original signal. When set to fully ‘wet’ (127/0), only the distorted signal is audible. When set to fully ‘dry’ (0/127), only the clean signal is audible.

# Chorus

In the 'Chorus' menu, you can adjust the settings for the rate, depth, delay and mix level of the chorus effect.

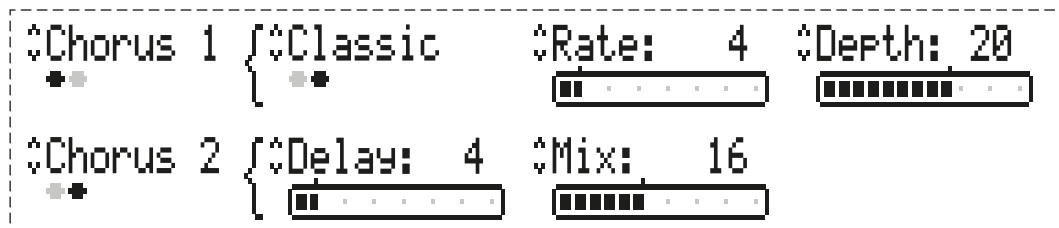

The pages of the 'Chorus' menu.

To edit the chorus parameters:

1. Turn encoder **A** to navigate to the first 'Chorus' page.
2. Turn or press encoder **B** to switch the chorus on or off.
3. Turn encoder **C** to adjust the rate of the chorus effect.
4. Turn encoder **D** to adjust the depth of the chorus effect.
5. Turn encoder **A** to navigate to the second 'Chorus' page.
6. Turn encoder **B** to adjust the chorus delay. This parameter determines how long the modulated copies of the signal are delayed before they are mixed back with the original signal. Lower settings result in a subtle effect, while higher settings produce a pronounced, shimmering effect. Use this parameter to change the character of the chorus.
7. Turn encoder **C** to set the mix level.

# Equalizer

In the 'EQ' menu, you can adjust the low-shelf, high-shelf and mid-parametric bands.

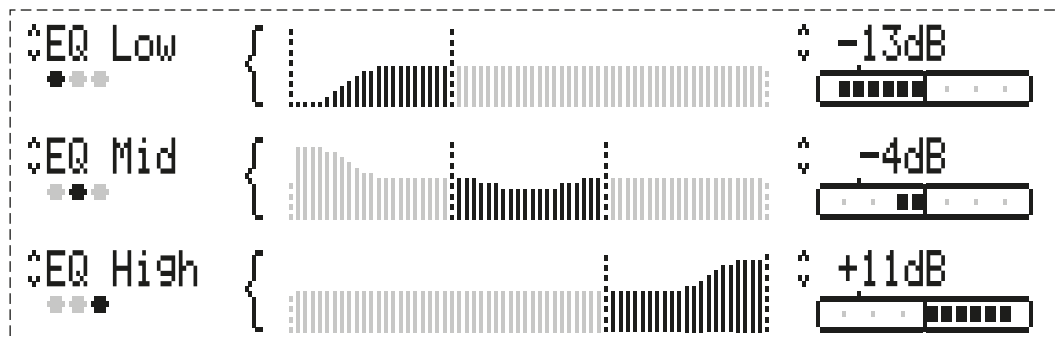

The pages of the 'EQ' menu.

To edit the equalizer parameters:

1. Turn encoder **A** to navigate to the 'EQ Low' page.
2. Turn encoder **D** to adjust the gain for the low-frequency band.
3. Turn encoder **A** to navigate to the 'EQ Mid' page.
4. Turn encoder **D** to adjust the gain for the mid-frequency band.
5. Turn encoder **A** to navigate to the 'EQ High' page.
6. Turn encoder **D** to adjust the gain for the high-frequency band.

# Delay

The first two pages of the ‘Send FX’ menu are dedicated to the delay effect. Here you can adjust the delay parameters and set the mix balance between the two send effects, delay and reverb.



The pages of the ‘Delay’ menu.

To edit the delay parameters:

1. Turn encoder **A** to navigate to the first ‘Delay’ page.
2. Turn encoder **B** to adjust the delay time in clock divisions
3. Turn encoder **C** to adjust the delay feedback. This parameter determines how often the delay signal is repeated. Low settings result in fewer repetitions, which, in combination with short delay times, is useful for creating slapback effects. When set to the highest amount and no damping, the signal is repeated indefinitely.
4. Turn encoder **D** to set the mix balance between the two send effects. Set the mix to ‘127/0’ to use only the delay.
5. Turn encoder **A** to navigate to the second ‘Delay’ page.
6. Turn encoder **C** to adjust the amount of damping. The higher the setting, the faster high frequencies in the delay signal are dampened.
7. Turn encoder **D** to set the mix balance between the two send effects. Set the mix to ‘127/0’ to use only the delay.

The following clock divisions are available for the delay time:

Setting	Clock Division	Delay Time
1/32	Thirty-second note	1/8 beat
1/32.	Dotted thirty-second note	3/16 beat
1/16T	Sixteenth note triplet	1/6 beat
1/16	Sixteenth note	1/4 beat
1/16.	Dotted sixteenth note	3/8 beat
1/8T	Eighth note triplet	1/3 beat
1/8	Eighth note	1/2 beat
1/8.	Dotted eighth note	3/4 beat
1/4T	Quarter note triplet	1/3 of 2 beats
1/4	Quarter note	1 beat
1/4.	Dotted quarter note	1 1/2 beats
1/2T	Half note triplet	1/3 of 4 beats
1/2	Half note	2 beats
1/2.	Dotted half note	3 beats
1/1T	Whole note triplet	1/3 of 8 beats
1/1	Whole note	4 beats



*The delay time is always synchronised to the internal or external clock signal.*

## Delay Freeze

The Delay Freeze function allows you to create sound-on-sound loops during your performance. To use this function:

1. Switch off the DMNO.
2. Connect a single or dual footswitch to the footswitch input.
3. Switch on the DMNO. When switched on, the DMNO automatically detects the polarity of the connected pedal, with the state of the footswitch at power-up taken as the 'off' state.
4. Set the **I/O** parameters **Footswitch Tip** and/or **Footswitch Ring** to one of the three 'Delay Freeze' options. For more information, see page 93.
5. To add notes or chords to the delay loop, release the footswitch while playing. Once you hold down the footswitch, no new notes will be added to the delay loop and its current content will be repeated endlessly.
6. Use the **FX SEND** potentiometers as well as the delay/reverb mix parameter in the 'Send FX' menu to set the level of the delay loop.
7. Use the delay time parameter in the 'Send FX' menu to set the length of the delay loop.
8. Use the delay feedback parameter in the 'Send FX' menu to ensure that looped notes are repeated at a constant level.



---

*Delay Freeze works best with long delay times and/or moderate to high feedback amounts.*

# Reverb

The second two pages of the ‘Send FX’ menu are dedicated to the reverb effect. Here you can adjust the reverb parameters and set the mix balance between the two send effects, delay and reverb.

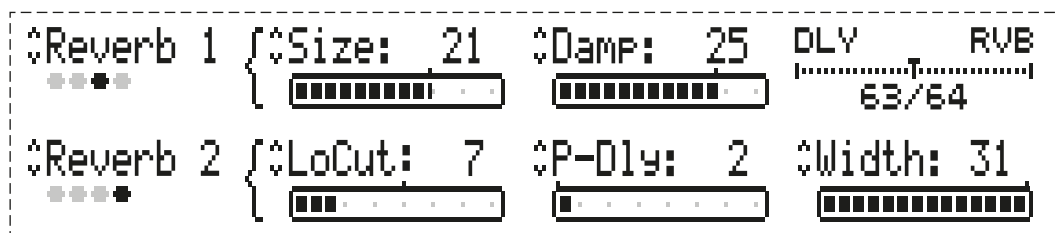

The pages of the ‘Reverb’ menu.

To edit the reverb parameters:

1. Turn encoder **A** to navigate to the first ‘Reverb’ page.
2. Turn encoder **B** to adjust the reverb size. A smaller size shortens the reverberation, while larger sizes prolong the duration of the reverb signal.
3. Turn encoder **C** to adjust the amount of damping. The higher the setting, the faster high frequencies decay. Higher values result in a warmer and darker reverberation, while lower values produce a brighter reverb signal.
4. Turn encoder **D** to set the mix balance between the two send effects. Set the mix to ‘0/127’ to use only the reverb.
5. Turn encoder **A** to navigate to the second ‘Reverb’ page.
6. Turn encoder **B** to adjust the low cut. This parameter determines to what extent low frequencies are removed from the reverb signal to keep it clear and defined.
7. Turn encoder **C** to adjust the pre-delay. This parameter determines the time interval between the unprocessed audio signal and the start of the processed reverb signal. The pre-delay prevents the reverb from masking the initial attack of a sound, allowing it to stand out more clearly in the mix.
8. Turn encoder **D** to adjust the reverb width. This parameter determines the stereo width of the reverb signal. Wider settings result in an immersive sound, while narrower settings keep the reverb more centred, thus maintaining clarity.

# GLOBAL SETTINGS

The global settings consist of parameters that affect the entire instrument, i.e. regardless of individual performance or patch settings. These include the selection of MIDI channels, calibration options and various settings for the DMNO's inputs and outputs.

To configure a global parameter:

1. Press the **[SHIFT]** button.
2. Press one of the numbered buttons (**1-8**) to access the desired menu. The respective parameters appear in the display.
3. Use encoders **A-D** to change a value, select an option or execute a command, depending on the column and the displayed option.
4. Repeat steps 2-3 if you wish to configure further parameters.
5. After making the desired setting(s), press the **[SHIFT]** button again to exit the global settings.

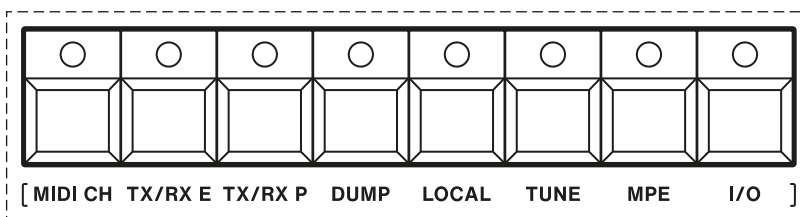

The control section relevant for the global settings.

## General MIDI Settings

Press **MIDI CH** to access the general MIDI settings.



The 'MIDI Channel' menu.

**Ch:** Turn encoder **A** to set the base MIDI channel. The selected MIDI channel is assigned to DMNO 1, while the subsequent MIDI channel is assigned to DMNO 2. For example, if you set the base MIDI channel to 5, MIDI channel 5 is assigned to DMNO 1 and MIDI channel 6 is assigned to DMNO 2.

**Omni:** Turn encoder **C** to switch Omni mode on or off. When on, the DMNO responds to MIDI messages on all 16 channels.

**MIDI Panic:** Press encoder **D** to reset all controllers. Think of this function as a MIDI panic button.

## Edited Parameter Settings

Press **TX/RX E** to specify whether or not parameter changes should be sent and received as MIDI CC messages.



The 'Tx/Rx Edits' menu.

**Tx Edits:** Turn encoder **A** to switch MIDI CC Transmit on or off. When on, the DMNO transmits MIDI CC messages.

**Rx Edits:** Turn encoder **C** to switch MIDI CC Receive on or off. When on, the DMNO receives MIDI CC messages.

## Program Change Settings

Press **TX/RX P** to specify whether or not the DMNO should send and receive Program Change messages.



The 'Tx/Rx Program Change' menu.

**Tx Prog. Change:** Turn encoder **A** to switch Program Change Transmit on or off. When on, the DMNO transmits Program Change messages.

**Rx Prog. Change:** Turn encoder **C** to switch Program Change Receive on or off. When on, the DMNO receives Program Change messages.

## Dumping Performances and Patches

Press **DUMP** to dump performances or patches as SysEx files via MIDI. This feature is reserved for future use.



The 'Dump' menu.

**Dump Performance:** Press encoder **A** to execute the command 'GO'. In this case, the DMNO dumps the current performance as a SysEx file.

**Dump Patch:** Press encoder **C** to execute the command 'GO'. In this case, the DMNO dumps the current patch as a SysEx file.

# Local Control

Press **LOCAL** to access the Local Control setting.



The 'Local Control' menu.

**Local Control:** Turn encoder **A** to switch Local Control on or off. When on, the front panel controls and keyboard are connected to the internal sound engine. When off, the front panel controls and keyboard have no effect on the sound engine. Disabling Local Control can be useful if you want to control external MIDI devices or avoid MIDI data loops during recording in a DAW.

## Tuning Settings

Press **TUNE** to access various settings and commands related to tuning. Turn encoder **A** to navigate through the pages of this menu.

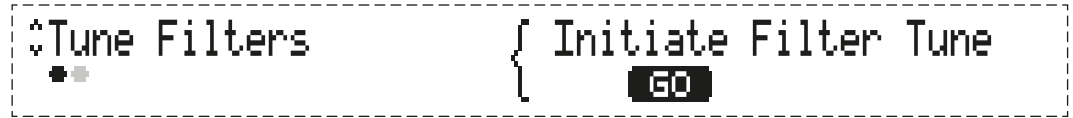

The 'Tune Filters' page.

**Initiate Filter Tune:** Press encoder **C** to execute the command 'GO' and calibrate the filters.



The 'Global Fine Adjust' page.

**Semi:** Turn encoder **C** to transpose the global pitch within a range of +/- 12 semitones. Pressing encoder **C** clears the current setting and resets the transposition to zero.

**Cent:** Turn encoder **D** to adjust the global fine tuning within a range of +/- 100 cents. Pressing encoder **D** clears the current setting and resets the tuning to 440 Hz.

## MPE Settings

Press **MPE** to access the MPE settings. This feature is reserved for future use.

# Inputs and Outputs

Press **I/O** to edit the settings for the inputs and outputs. Turn encoder **A** to navigate through the pages of this menu.



The 'Footswitch Tip' page.

**Footswitch Tip:** Turn encoder **C** to set the footswitch tip function.

- If set to 'No Operation', a single footswitch or the left switch of a dual footswitch will not sustain any notes.
- If set to 'Omni Hold', a single footswitch or the left switch of a dual footswitch sustains the notes that trigger both synthesizer modules.
- If set to 'DMNO1 Hold', a single footswitch or the left switch of a dual footswitch sustains the notes that trigger DMNO 1.
- If set to 'DMNO2 Hold', a single footswitch or the left switch of a dual footswitch sustains the notes that trigger DMNO 2.
- If set to 'Omni Delay Freeze', a single footswitch or the left switch of a dual footswitch controls the Delay Freeze function (see page 86) for both synthesizer modules.
- If set to 'DMNO1 Delay Freeze', a single footswitch or the left switch of a dual footswitch controls the Delay Freeze function for DMNO 1.
- If set to 'DMNO2 Delay Freeze', a single footswitch or the left switch of a dual footswitch controls the Delay Freeze function for DMNO 2.

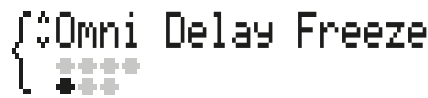
The 'Footswitch Ring' page.

**Footswitch Ring:** Turn encoder **C** to set the footswitch ring function. The available settings only have an effect when using a dual footswitch with a TRS (Tip-Ring-Sleeve) connector.

- If set to 'No Operation', the right switch of a dual footswitch will not sustain any notes.
- If set to 'Omni Hold', the right switch of a dual footswitch sustains the notes that trigger both synthesizer modules.
- If set to 'DMNO1 Hold', the right switch of a dual footswitch sustains the notes that trigger DMNO 1.
- If set to 'DMNO2 Hold', the right switch of a dual footswitch sustains the notes that trigger DMNO 2.
- If set to 'Omni Delay Freeze', the right switch of a dual footswitch controls the Delay Freeze function (see page 86) for both synthesizer modules.
- If set to 'DMNO1 Delay Freeze', the right switch of a dual footswitch controls the Delay Freeze function for DMNO 1.
- If set to 'DMNO2 Delay Freeze', the right switch of a dual footswitch controls the Delay Freeze function for DMNO 2.



The 'CV' page.

**CV:** Turn encoder **B** to set the source for CV output 1. Turn encoder **C** to set the source for CV output 2.

- If set to 'DMNO1 Note', the notes that trigger DMNO 1 determine the output control voltage. In this case, the CV output is configured for the standard 1 volt per octave and covers a range of 8 octaves, with middle C being generated at 4 volts.
- If set to 'DMNO2 Note', the notes that trigger DMNO 2 determine the output control voltage. In this case, the CV output is configured for the standard 1 volt per octave and covers a range of 8 octaves, with middle C being generated at 4 volts.
- If set to 'DMNO1 Velo', the velocity of the notes that trigger DMNO 1 determines the output control voltage.
- If set to 'DMNO2 Velo', the velocity of the notes that trigger DMNO 2 determines the output control voltage.
- If set to 'Aftertouch', aftertouch determines the output control voltage.
- If set to 'Mod. Lever', pushing the bender upwards determines the output control voltage.
- If set to 'Env. Follow', the envelope follower determines the output control voltage.



The 'Gate' page.

**Gate:** Turn encoder **B** to set the source for gate output 1. Turn encoder **C** to set the source for gate output 2.

- If set to 'DMNO1 Gate', the notes that trigger DMNO 1 determine the gate signal.
- If set to 'DMNO2 Gate', the notes that trigger DMNO 2 determine the gate signal.
- If set to 'Env. F. Gate', the envelope follower determines the gate signal.

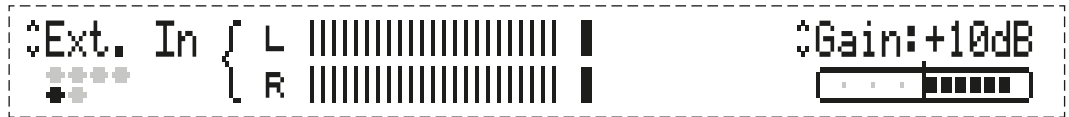

The 'Ext. In' page.

**Ext. In:** Turn encoder **D** to set the input gain level for an external audio signal within a range of +/- 12 dB. Refer to the level meter when adjusting the level. This setting is important for the envelope follower to function correctly. The audio signal will not clip when you turn the gain up all the way.



The 'Aux Out Source' page.

**Aux Out Source:** Turn encoder **C** to set the audio source for the auxiliary outputs.

- If set to 'USB Audio', the USB audio signal is routed through the auxiliary outputs. The USB audio signal is identical with the main mix output, including external audio signals processed by DMNO 1. When using the DMNO as an audio interface, everything routed to its outputs, such as the aux channels of a DAW for playback of a track or an entire mix, also becomes part of the USB audio signal.
- If set to 'DMNO1', the output signal from DMNO 1 is routed through the auxiliary outputs.
- If set to 'DMNO2', the output signal from DMNO 2 is routed through the auxiliary outputs.
- If set to 'Main Mix', the main mix is routed through the auxiliary outputs.



*If 'Main Mix' is selected as the audio source for the auxiliary outputs, the audio signal of the main mix can be fed back into the DMNO. To do this, do not connect anything to the audio inputs, in which case they will be normalised to the auxiliary outputs. This allows you to overdrive the internally generated audio signal by using the **EXT** potentiometer in the filter section of DMNO 1.*

## Resetting the Global Parameters

If your DMNO is not behaving as expected, you can reset the global parameters to their default settings.

To reset the global parameters:

1. Press and hold the **MANUAL** button.
2. The message “MANUAL MODE (HOLD FOR GLOBAL RESET)” appears in the display. Continue to hold the **MANUAL** button.
3. After about 5 seconds the message “GLOBAL SETTINGS RESET OK!” appears.
4. Release the **MANUAL** button.

# UPDATING THE FIRMWARE

---

To update the firmware of the DMNO:

1. Go to the support section of the UDO website to download the latest firmware to your computer and extract the ZIP file (.zip).
2. Unlock the DMNO's drive:
  - Turn off the DMNO and wait a few seconds.
  - Press and hold the **[SHIFT]** button, turn on the DMNO and continue to hold the **[SHIFT]** button.
  - The LED for LFO 1 on DMNO 1 begins to flash.
  - Release the **[SHIFT]** button.
3. Connect the DMNO to your computer using a USB cable.
4. The DMNO's drive appears as a disk drive named **DMNO** on your computer.
5. Delete the firmware file 'dom\_v#.##.bin' from the **DMNO** drive. Make sure to empty the trash folder if you are a macOS user, or the update won't be possible.
6. Copy the latest firmware file 'dom\_v#.##.bin' from your computer to the **DMNO** drive. If you are asked whether you want to copy files without properties, select 'Yes'. Please note that this process may take a few minutes. Do not switch off the DMNO or disconnect the USB cable whilst the transfer is in progress!
7. When the transfer is complete, disconnect the USB cable.
8. Turn off the DMNO, wait a few seconds, and then turn it back on.



*When the DMNO's drive is unlocked, you cannot play it, but only manage or change the files stored on it.*

# MANAGING FILES

---

By unlocking the DMNO drive and connecting it to a computer, you can easily access and organise the stored performances, patches and alternative waveforms. This is useful for sharing and backing up related files.

To unlock the DMNO's drive:

1. Turn off the DMNO and wait a few seconds.
2. Press and hold the **[SHIFT]** button, turn on the DMNO and continue to hold the **[SHIFT]** button.
3. The LED for LFO 1 on DMNO 1 begins to flash.
4. Release the **[SHIFT]** button.

If you then connect the DMNO to your computer via a USB cable, it will appear on your computer as a drive named 'DMNO', which you can access just like any other flash drive.

The DMNO's drive contains the firmware file, the Init Patch file and four folders: 'performances\_a', 'patch\_banks\_a', 'waveforms' and 'alt\_waveforms'.

The 'performances\_a' and 'patch\_banks\_a' folders each contain up to 16 subfolders: one for each bank. Each of the bank folders 'a1' to 'h2' stores up to 8 performance or patch files. The 'waveforms' folder contains the first group of 16 alternative waveforms (1-16), while the 'alt\_waveforms' folder contains the second group of 16 alternative waveforms (17-32).



*When the DMNO's drive is unlocked, you cannot play it, but only manage or change the files stored on it.*

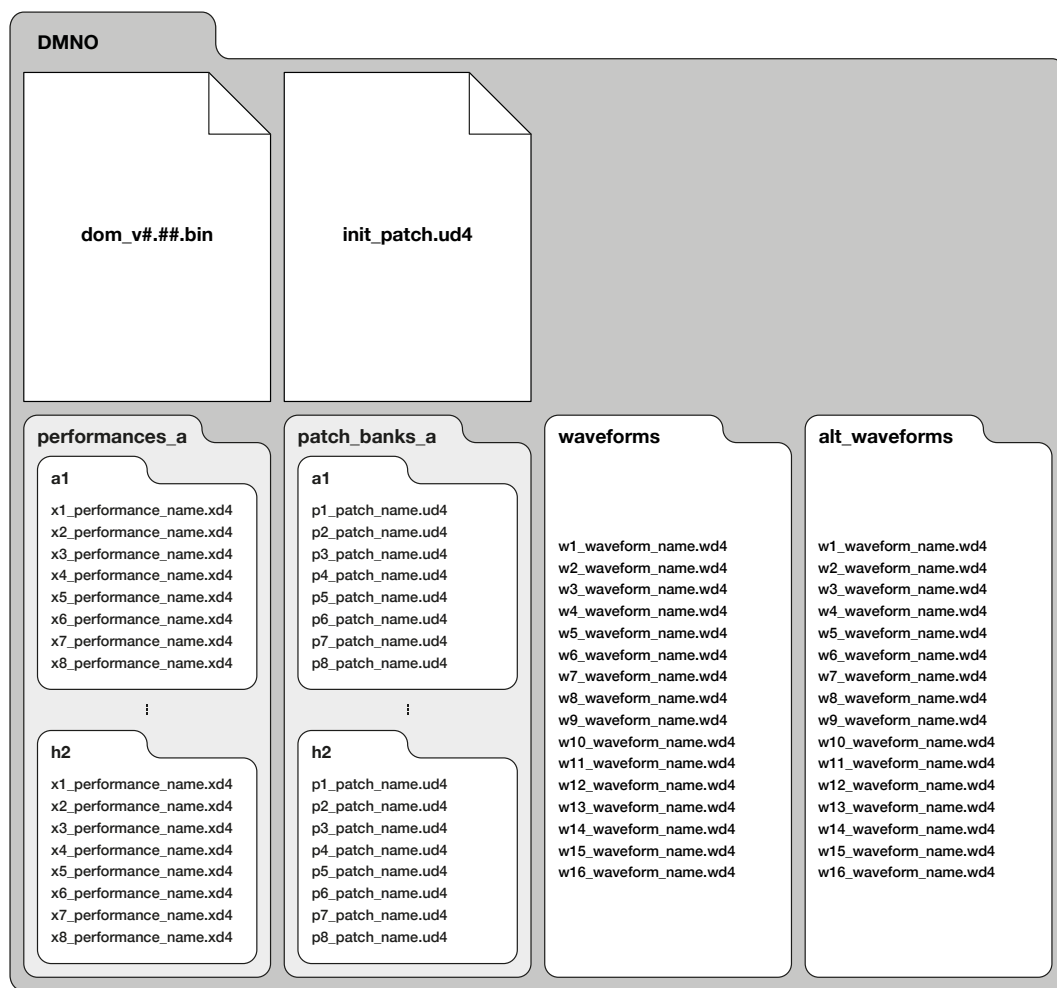

The file structure of the DMNO's drive.

## File Name Convention

The first character of each file – **x**, **p**, or **w** – serves as a prefix for performance, patch and waveform files. The second character indicates the slot for the performance, patch or waveform. Use the numbers 1–8 for performances and patches. Use the numbers 1–16 for alternative waveforms.

**Performance files:** `x1_performance_name.xd4`

**Patch files:** `p1_patch_name.ud4`

**Waveform files:** `w1_waveform_name.wd4`

After the prefix, the number and an underscore, you are free to choose any name for performances, patches and waveforms to make it easier for you to identify the files. However, you should avoid spaces and use underscores instead.

# Importing Performances and Patches from Your Computer

1. Follow steps 1-4 on page 100 to unlock the DMNO's drive.
2. Connect the DMNO to your computer using a USB cable.
3. The instrument appears on your computer as a drive named 'DMNO'.
4. Click on the icon of the DMNO's drive.
5. Navigate to the folder 'performances\_a' or 'patch\_banks\_a'.
6. Open the desired bank folder ('a1' to 'h2').
7. Copy the performance or patch files you would like to transfer to the DMNO and paste them into the folder you selected in the previous step. If asked whether you want to copy files without properties, select 'Yes'. Do not turn off the DMNO or unplug the USB cable during the transfer!

If necessary, change the name prefix of the copied and pasted files so that they match the desired memory location. Ensure that you manually delete the files to be replaced in the selected folder if the names of the new files do not match the names of the old files. Empty the trash bin on your computer to ensure that the files are actually deleted from the DMNO's drive.

8. Once the transfer is complete, disconnect the USB cable.
9. Turn off the DMNO, wait a few seconds, and then turn it back on.



*If you wish to replace entire banks, you can skip steps 6-8 and instead delete a bank folder and then replace it with the desired bank folder. In this case, make sure that the letter of the new bank folder matches that of the replaced folder.*



*UDO will periodically release additional sound packs, which can be downloaded at [www.udo-audio.com/support-downloads](http://www.udo-audio.com/support-downloads).*

## Importing Waveforms from Your Computer

1. Follow steps 1-4 on page 100 to unlock the DMNO's drive.
2. Connect the DMNO to your computer using a USB cable.
3. The instrument appears on your computer as a drive named 'DMNO'.
4. Click on the icon of the DMNO's drive.
5. Navigate to the folder 'waveforms' or 'alt\_waveforms'.
6. Copy the waveform files you would like to transfer to the DMNO and paste them into the folder you selected in the previous step. If asked whether you want to copy files without properties, select 'Yes'. Do not switch off the DMNO or unplug the USB cable during the transfer!  
  
If necessary, change the name prefix of the copied and pasted files so that they match the desired memory location. Ensure that you manually delete the files to be replaced in the selected folder if the names of the new files do not match the names of the old files. Empty the trash bin on your computer to ensure that the files are actually deleted from the DMNO's drive.
7. Once the transfer is complete, disconnect the USB cable.
8. Switch off the DMNO, wait a few seconds, and then turn it back on.



---

*UDO will periodically release additional waveform packs, which can be downloaded at [www.udo-audio.com/support-downloads](http://www.udo-audio.com/support-downloads).*

## Backing up Performances and Patches on Your Computer

1. Connect the DMNO to your computer using a USB cable.
2. The instrument appears on your computer as a drive named 'DMNO'.
3. Click on the icon of the DMNO's drive.
4. Click on the 'performances\_a' or 'patch\_banks\_a' folder and copy it to your computer's hard drive. You can also navigate to one of the 16 bank folders ('a1' to 'h2') or to a single file within these subfolders to copy it to your computer's hard drive.

## Backing up Waveforms on Your Computer

1. Connect the DMNO to your computer using a USB cable.
2. The instrument appears on your computer as a drive named 'DMNO'.
3. Click on the icon of the DMNO's drive.
4. Click on the 'waveforms' or 'alt\_waveforms' folder and copy it to your computer's hard drive. You can also navigate to a single waveform file within these folders to copy it to your computer's hard drive.

## Creating Your Own Alternative Waveforms

If you wish to create your own alternative waveforms, ensure that the files comply with the following standards:

- 16-bit signed integer format samples
- Normalised single-cycle waveform with 2048 points
- Band-limited at sampling frequency/4 (Nyquist/2), i.e. frequency content above 512 Hz in your 2048-point waveform should be removed
- Binary file without header data and with the file extension '.wd4'.

# MIDI SPECIFICATIONS

## System Real-Time Messages

Control Function	Transmit	Receive
MIDI Timing Clock	Yes	Yes
Start	Yes	Yes
Stop	Yes	Yes

## Channel Messages

Control Function	Transmit	Receive
Note Off	Yes	Yes
Note On	Yes	Yes
Polyphonic Key Pressure	No	Yes
Control Change	See “Global Settings” (page 89)	See “Global Settings” (page 89)
Program Change	See “Global Settings” (page 90)	See “Global Settings” (page 90)
Channel Pressure	Yes	Yes
Pitch Bend	Yes	Yes

Head to our [Support & Downloads page](#) for the most up to date MIDI specification.

# GLOSSARY

---

The following list contains brief explanations of the key terms printed on the front panel of the DMNO, as well as the basic synthesis terminology used throughout this manual.

**Aftertouch:** Aftertouch is a modulation source that allows you to modulate a sound via key pressure while holding a note.

**All-Pass Filter (AP):** An all-pass filter passes the entire frequency spectrum with equal gain and only changes the phase relationship of the signal. Different frequencies are phase-shifted by different amounts depending on the cutoff frequency of the filter. Use this filter type to manipulate the phase of a signal without altering its level.

**Arpeggiator:** An arpeggiator generates arpeggios based on a held chord. An arpeggio is a ‘broken chord’ in which the notes of a chord are played one after the other in an order determined by the current playback mode setting.

**Band-Pass Filter (BP):** A band-pass filter subtracts frequency content above and below its cutoff frequency. Only a narrow frequency range passes through the filter unchanged. Use this filter type to create nasal sounds.

**Bender:** A bender is a performance controller that can be moved along two axes: horizontally (left/right) and vertically (upwards). The corresponding gestures can affect the sound in different ways.

**Binaural:** The Latin term ‘binaural’ literally means ‘with both ears’. In Binaural mode, the available four voices of each synthesizer module are combined into two stereo ‘super voices’ per module. The effect on the sound ranges from subtle to extreme stereo movements and an enhanced sense of spatial positioning compared to conventional monaural signal chains.

**Bi-timbrality:** A bi-timbral synthesizer is an instrument that can generate two different sounds simultaneously, each controlled by a different MIDI channel.

**Chaos Mode:** In this mode, the voices of both synthesizer modules are triggered in random order with curated note randomisation that can be set in the menu for the voice settings.

**Clock Signal:** A clock signal works like a metronome. Typically, a square wave is used, which oscillates at a constant frequency between high and low levels to synchronise instruments or parameters such as sequencers, LFOs or time-based effects. An external clock signal is fed into your instrument from another device, such as your DAW.

**Clock Synchronisation:** This function allows you to synchronise modules of a system, such as an arpeggiator, LFOs and time-based effects, with an internal or external clock signal. During synchronisation, parameters like the LFO rate or delay time respond at a rate that is relative to the clock signal. By using different clock divisions (quarter notes, eighth notes, etc.) for each parameter, you can achieve complex rhythmic effects.

**Cross Modulation:** Cross modulation is a type of frequency modulation (FM) the result of which depends on the frequency ratio between two oscillators. It can be used to create complex, clangorous or bell-like timbres.

**Cutoff:** This filter parameter allows you to set the point at which the filter begins to subtract frequencies from the raw oscillator signals to shape the sound.

**CV Output:** A CV output allows you to send control voltages to modular synthesizers and other devices that support this type of connection. The control voltages can be used to control various parameters, such as the pitch of oscillators or the cutoff frequency of a filter.

**Cycle Mode:** In this mode, the voices of both synthesizer modules are triggered alternately by default each time a note is played.

**Delay Freeze:** This function transforms the delay effect into a simple looper, allowing you to create sound-on-sound loops that you can play along with.

**$\Delta$ -Cutoff:** This filter parameter offsets the cutoff frequency of the two filters used per voice relative to each other, allowing you to adjust the spread of the two filter peaks. The parameter is bipolar. Turning the respective control clockwise raises the cutoff frequency of the first filter above that of the second filter. Turning it counterclockwise lowers the cutoff frequency of the first filter below that of the second filter. In the centre position, the cutoff frequencies of both filters are identical.

**Detune:** This parameter determines the extent to which the six 'sister oscillators' of each oscillator are detuned and spread across the stereo field relative to the centroid oscillator.

**Direct Digital Synthesis (DDS):** Direct Digital Synthesis is the signal generation method used by both oscillator cores. At its heart is a clock signal running three orders of magnitude higher than typical audio sample rates. This clock increments a counter through thousands of indices in your chosen waveform, generating samples every 20 billionths of a second and interpolating between them. Each numerically controlled oscillator then uses its own DAC, which also runs at the same high sampling rate, to convert the samples into analog voltages before they are filtered by a preliminary analog low-pass filter stage.

**Dual Mode:** In this mode, the voices of both synthesizer modules are triggered simultaneously with each note played.

**Envelope:** An envelope is a modulation source that determines how the modulated signal or parameter develops over time. The envelope generators of the DMNO contain four stages that allow you to define the shape of the envelope: attack, decay, sustain and release (ADSR). In addition, the first and third envelopes of each synthesizer module feature an attack hold phase that determines the time between pressing a key and the start of the attack stage.

**Envelope Follower:** An envelope follower generates a control signal based on the amplitudes of an incoming audio signal. This allows you to add dynamics to your sounds, for example by attenuating the VCA level in time with a drum loop for sidechaining effects.

**Equalizer (EQ):** An EQ shapes the sound of an audio signal by altering the level of specific frequency bands. EQs are used to subtly or significantly shape a sound by adjusting specific frequencies or frequency ranges. The DMNO features a 3-band EQ with an adjustable Q factor that allows you to set the bandwidth for the midrange frequencies.

**FPGA:** A field-programmable gate array (FPGA) is an integrated circuit (IC) that can be configured after manufacture, hence the term 'field-programmable'. Its advantage lies in the fact that it is significantly faster due to its parallelism and the optimal number of gates for specific processes. An FPGA contains an array of programmable logic blocks and a hierarchy of reconfigurable connections that allow blocks to be 'wired' together in a variety of configurations, similar to different modules.

**Gate Output:** A gate output allows you to send an on/off control voltage signal to modular synthesizers and other devices that support this type of connection. Gate signals are typically used to trigger envelopes.

**High-Pass Filter (HP):** A high-pass filter subtracts frequency content below its cutoff frequency. Frequency content above the cutoff frequency remains unaffected, allowing high frequencies to pass through. Use this filter type to make sounds thinner or brighter by reducing the bass frequencies.

**Keyboard Tracking:** Keyboard tracking is a type of modulation that uses the MIDI note number as the modulation source. All parameters linked to keyboard tracking respond relative to the pitch of the notes played.

**Layer:** In a bi- or multitimbral synthesizer, a layer is essentially a placeholder for a patch. With the DMNO, you can play two layers simultaneously, either in Dual or Split mode. Each of the two layers contains its own patch.

**Loop:** A loop is essentially a repetition of a recording or a shape, meaning that once its end is reached, the looped phrase starts all over again. The first and third envelopes of each synthesizer module feature a loop option, and the delay freeze function allows you to create looped phrases.

**Low Frequency Oscillator (LFO):** An LFO is an oscillator that generates frequencies below the range of human hearing. It can be used to create periodic modulations such as vibrato effects (modulated pitch) or tremolo effects (modulated VCA level).

**Low-Pass Filter (LP):** A low-pass filter subtracts frequency content above its cutoff frequency. Frequency content below the cutoff frequency remains unaffected, allowing low frequencies to pass through. Use this filter type to make sounds warmer or emphasise the bass frequencies.

**MIDI:** Musical Instrument Digital Interface. MIDI is a standardised protocol that enables communication between different devices from different manufacturers. This includes not only instruments, but also computers and various types of controllers.

**Mixer:** The mixer allows you to adjust the overall volume as well as the output level of both synthesizer modules, pan their audio signals, and determine how much of each signal is fed into the effects inputs.

**Modulation:** Modulation is the process by which the behaviour of a signal or parameter (the modulation destination) is controlled by another signal or parameter (the modulation source). For example, an LFO can control the pitch of an oscillator, or an envelope can control the loudness of a sound. Common modulation sources are LFOs, envelopes, oscillators and performance controls such as aftertouch and velocity.

**MPE:** MIDI Polyphonic Expression. This is a standardised protocol that allows sound engines or synthesizers to be played via dedicated MPE controllers. MPE controllers emulate the complex articulation of individual notes on acoustic instruments. Each pad or key on an MPE controller allows simultaneous gestures across multiple axes (pressure, left/right, up/down) that impact how each individual note is articulated while a pad or key is held. How hard you strike a pad or key and how quick or slow you release it also affects the sound of the note. MPE controllers transmit MIDI messages via an individual MIDI channel per note.

**One-Two Mode:** In this mode, the first note played triggers the voices of the first synthesizer module by default, while the following notes trigger the voices of the second synthesizer module.

**Oscillator:** Oscillators are among the most fundamental and essential components of a synthesizer. Without them, you could neither hear a sound nor shape or modulate what is generating an audio signal. The oscillators of both synthesizer modules generate classic waveforms such as sine, sawtooth, square, triangle, pulse and white noise. In addition, each oscillator features up to six user-configurable waveforms.

**Oscillator Sync:** This function, also known as 'hard sync', forces the synchronised oscillator to restart its duty cycle each time the duty cycle of the oscillator it is synchronised to starts. By setting the frequency of the synchronised oscillator to a higher pitch than the oscillator it is synchronised to, you can create complex and harmonically rich timbres.

**Overdrive:** If you increase the output level of the three possible audio sources in the filter section of each synthesizer module, you can overdrive the audio signal fed into the filter. This feature allows you to either saturate or distort your sounds.

**Patch:** A patch is a stored set of parameters that determine the characteristics of a sound.

**Performance:** A performance is essentially a snapshot of the entire instrument, consisting of the settings for both layers or synthesizer modules, the settings for the performance control section, arpeggiator settings, as well as the voice, effect and mixer settings, with the exception of the **VOLUME** control, which is a non-storable parameter.

**Phase:** This parameter controls the phase relationship between the left and right channels of the binaural sound engine, i.e. the effect of LFO 1 on the stereo field.

**Phase Shifter (PS):** The phasing effect is created by mixing a signal processed by an all-pass filter with the untreated original signal. When the two signals are mixed, the phase-shifted frequencies cancel each other out and produce the characteristic notches of the phaser. To achieve a typical phaser effect, modulate the cutoff frequency with an LFO.

**Play Mode:** A Play mode determines how both synthesizer modules interact with each other and in what order their voices are triggered by the notes played on the keyboard or by the arpeggiator.

**Poles:** The number of poles determines the cutoff slope of a filter, with each pole providing a slope of 6 dB per octave. The higher the number, the steeper the curve and the stronger the filter attenuates frequencies beyond its cutoff frequency. A 2-pole filter, for example, has a slope of 12 dB per octave, resulting in a level drop of 12 dB per octave. A 4-pole filter, on the other hand, has a slope of 24 dB per octave, resulting in a level drop of 24 dB per octave.

**Portamento:** Portamento is a pitch glide effect between consecutive notes. The longer the portamento time, the longer it takes for a note to glide to the pitch of the following note. The portamento time is also determined by the intervals between the notes played: smaller intervals result in faster pitch glides, while larger intervals result in slower pitch glides.

**Pulse Width:** The pulse width indicates how long a pulse signal is 'switched on'. It is usually measured as a percentage of the duty cycle. A duty cycle of 50% produces a square wave, which means that the pulse signal is switched on for the same amount of time as it is switched off per duty cycle. Changing the on-off ratio alters the harmonic content and thus also the timbre. The sound of a pulse wave with a duty cycle of more or less than 50% is thinner than that of a square wave and has a nasal character. At a duty cycle of 0% or 100%, no sound is heard because there is no change in amplitude that could generate an oscillation.

**Pulse Width Modulation (PWM):** Pulse width modulation affects how the pulse width changes over time while you hold a note. The pulse width can be modulated by a modulation source such as an LFO or an envelope, resulting in a thicker or more harmonically interesting sound.

**Random Mode:** In this mode, the voices of both synthesizer modules are triggered in random order with each note played.

**Resonance:** This filter parameter emphasises the frequencies around the cutoff frequency. The filter of each synthesizer module can be driven into self-oscillation by setting the resonance to the highest amount. In this case, the filter will generate a pitch determined by the cutoff frequency and a sound similar to a sine wave.

**Series Mode:** In this mode, the output signal of the first synthesizer module is used as a complex oscillator and routed into the oscillator mixer of the second synthesizer module.

**Single Mode:** In this mode, only the voices of one synthesizer module are triggered with each note played.

**Split Mode:** In this mode, the voices of each synthesizer module are assigned to one side of a split point on the keyboard.

**Super Mode:** This feature utilises the stereo signal path of each synthesizer module. In Super mode, the classic oscillator waveforms (sine, sawtooth, square, triangle and pulse) can be dynamically phase-shifted in the stereo field, resulting in a thick, wide sound from a single oscillator. Technically speaking, Super mode is always active. Its effect becomes audible when you set a value using the **DETUNE** parameter.

**Swing:** Swing is a rhythmic variation in which the first and second consecutive notes of a two-part beat pattern are alternately lengthened and shortened. Swing is used to make a rhythm pattern ‘bounce.’

**Velocity:** Velocity is a modulation source that allows a sound to respond dynamically when you play a key. For example, if velocity controls the behaviour of the VCA, the softer you play, the quieter the sound will be. Conversely, the harder you hit the keys, the louder the sound will be.

**Voltage-Controlled Amplifier (VCA):** A voltage-controlled amplifier controls the loudness of a sound. In each synthesizer module, the second envelope is routed to the VCA level by default. This envelope lets you determine how the loudness of a sound changes over time.

**Voltage-Controlled Filter (VCF):** This building block gave subtractive synthesis its name. The voltage-controlled filters are an essential part of the DMNO’s sonic character, shaping the sound of the oscillators by subtracting frequencies from their signals.

**Waveform:** A waveform describes the shape of a signal generated by an oscillator. Classic analog waveforms include shapes such as sine, sawtooth, square, triangle, pulse and white noise. A sine wave contains only the first harmonic, the fundamental, which is why it is considered the purest waveform. A sawtooth wave contains both odd and even harmonics and sounds bright. Square and pulse waves contain a wide range of odd harmonics and they sound hollow and can be used for reed-like sounds. A triangle wave contains only odd harmonics and sounds very soft. White noise contains all frequencies and is useful for creating wind or percussion sounds.

**Wave Modulation:** This type of modulation allows you to crossfade between two adjacent waveforms.

# SUPPORT INFORMATION

---

If you are experiencing any issues with your DMNO, please contact our technical support team at [support@udo-audio.com](mailto:support@udo-audio.com).

Please provide the following information when contacting us:

- Instrument name
- Serial number
- Current firmware version
- Date of purchase (please specify whether new or used) and dealer (please specify location)

If you have not already done so, please register your product via our [website](#). This is not required for warranty services, but it does speed up the support process.

You may also visit our [FAQ section](#) or [user forum](#) to check whether your question has already been answered.



8 VOICE POLYPHONIC DUAL MODULE  
BINAURAL ANALOG-HYBRID SYNTHESIZER  
WITH DYNAMIC SIGNAL ARCHITECTURE

UDO DMNO  
OWNER'S MANUAL

©2026 UDO AUDIO  
VERSION 1.1 · APRIL 2026

[UDO-AUDIO.COM](http://UDO-AUDIO.COM)

**U·D·O<sup>®</sup>**