



Medium Electric Forklift

ECG90-180 Lithium-ion or Lead Acid



The time is now to go electric

Kalmar's electrically powered 9-18 tonne medium forklift trucks will help improve the eco-efficiency of your operations while maintaining the highest levels of productivity and safety. With a choice of either Lead Acid or Lithium-ion batteries and different charging solutions, we can work with you to design a solution that will deliver for your business.

Zero emissions at source

Being electrically powered, your forklift truck will produce zero carbon emission at source, making them cleaner and safer to operate. You can cut your carbon emissions even further by using green energy sources where available or start to generate and use your own power. Getting an electrically powered forklift is only the start of our eco-efficient journey. One that we will be with you every step of the way.

Productive by nature

With an electric powered driveline your drivers will notice a big difference with faster and smoother acceleration and more responsive handling while still being able to lift up to 18 tonnes efficiently and safely. Less time will be spent servicing and maintaining the electric powertrain since it has less moving and mechanical parts, plus you will be able to keep it running optimally within a broad range of temperatures, with Kalmar's Thermal Management System fitted to the Li-ion battery version as standard.

Safety in focus

Kalmar's range of electrically powered 9-18T forklift trucks offer highly responsive handling and superior visibility from the cabin, helping to keep your driver safe and in control at all times. Your drivers and co-workers will also benefit from the reduced noise and vibrations with a smooth and quiet electric powertrain. There are also a large range of safety options available that can further enhance the safety of your equipment and the drivers operating them.

A full range

Kalmar offers an extensive range of electrically powered forklift trucks with a choice of two different battery technologies, lifting capacities up to 18 tonnes, different masts and numerous attachments we can work with you to design a solutions that delivers against your exact requirements.

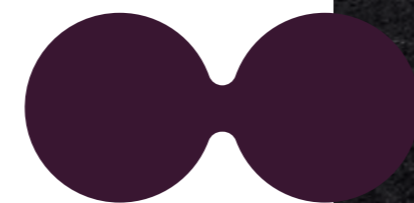
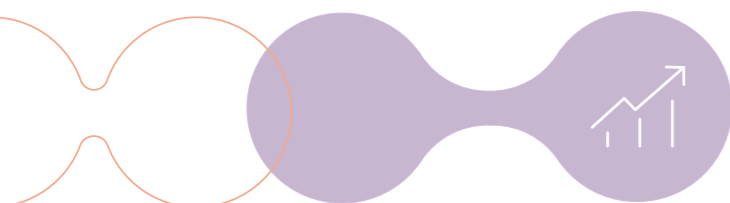

Improve your eco-efficiency while maintaining the highest levels of productivity and safety.

Our electric portfolio

Kalmar offers an extensive range of electrically powered forklift trucks with lifting capacities from 5-33 tonnes (Light 5-9T, Medium 9-18T and Heavy Duty 18-33T), three different lifting masts and a wide range of specialist attachments: making our electrically powered forklift trucks suitable for a wide variety of material handling tasks.

Battery and Charging Monitoring

Real-time status on battery capacity and health along with charging usage and timing allows for optimised operational planning and usage.

MyKalmar INSIGHT*

MyKalmar INSIGHT gives you the ability to monitor your fleet's operational status in real time no matter what type of your equipment you operate.

Additional Energy Storage

You can use additional energy storage units to capture excess power that you may have produced to use at a later time when required instead of buying from the grid.

Charging Post for Li-ion Equipment

Chargers with REMA connectors for 80V resp. 120V charging of ECG50-90 and ECG90-180 ranges, or charging post with high voltage CCS2/CCS1 connector for ECG180-330 range, reachstackers and empty container handlers.

Reachstackers

Kalmar offers a choice of electrically powered reachstackers with a wide range of lifting applications, battery solutions and can handle loads up to 45 tonnes.

Empty Container Handler

Kalmar's range of electrically powered empty container handlers can operate for up to a full shift on a single charge, lifting loads up to 11 tonnes and placing them up to 8+1 high with our double stacker.

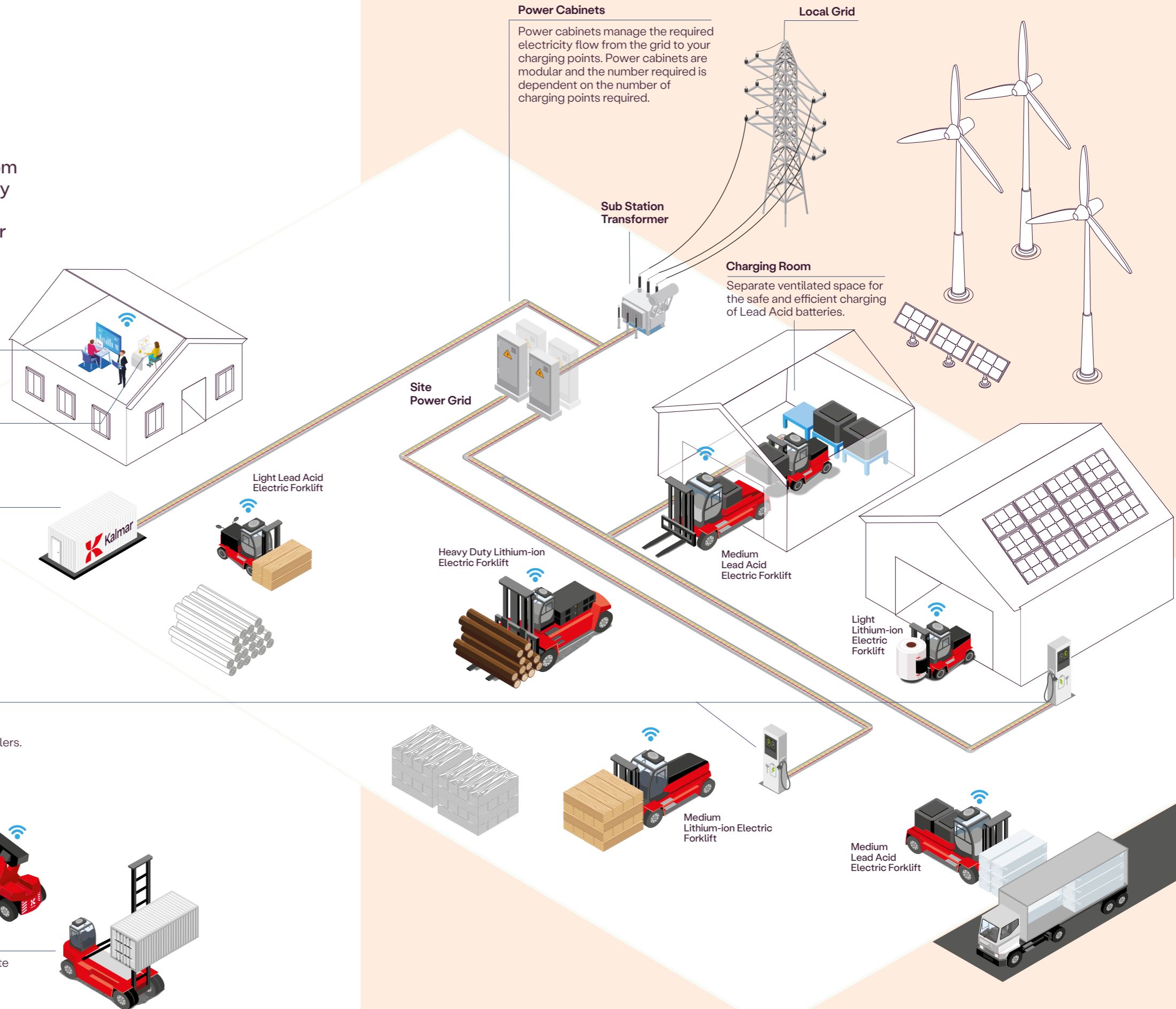

* MyKalmar INSIGHT access is through a separate subscription agreement.

Great for the environment

What type of battery solution is right for you?

Kalmar offers two types of battery technology to power its forklifts, Lead Acid and Lithium-ion. Here is a chart that demonstrates the difference between the two battery types so you can decide which is the right solution for your operations.

The Lead Acid battery can be charged directly in a safe location without removal, or it may be removed after a shift and fully charged before being refitted onto the forklift. The Lithium-ion battery can be continuously recharged during operational downtime or statutory break.



Lead Acid



Lithium-ion

Charging pattern

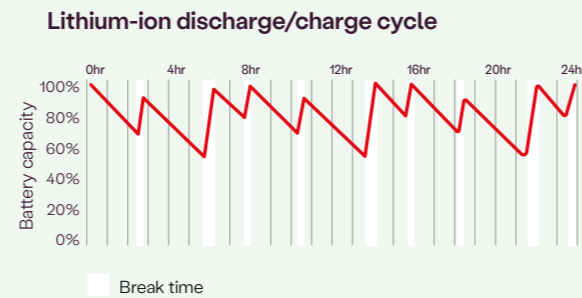
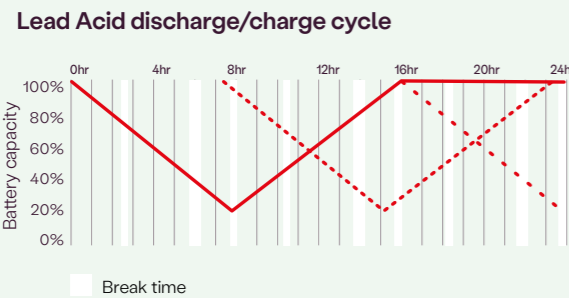

Features

- Cell lifespan:**
- Up to 1,250 - 1,500 cycles (1 cycle = 80% nominal capacity)
- Battery efficiency:**
- ~ 70 - 80%
- Maintenance:**
- Requires regular water topping, cleaning, checking for leakages and electrolyte level
 - Requires ventilated charging space
 - 2 or 3 shift operation possible with exchange batteries. One battery set per shift.

- Cell lifespan:**
- Up to 3,500 - 5,000 cycles (1 cycle = 80% nominal capacity)
- Battery efficiency:**
- ~ 90 - 95%
- Maintenance:**
- No regular maintenance required
 - No special requirements for charging space
 - Requires time slots for opportunity charging defined by discharging:charging ratio.

Your operations

What is your operational cycle?

8hrs (6-12hrs)

Shift operations:

- 1-shift with 1 battery
- 2-shift with 2 battery sets
- 3-shift with 3 battery sets.

Charging time **Cooling time**

7 - 8 hours 7 - 8 hours

Based on 80% charge.

What is your operational cycle?

8hrs (4-8hrs)

Shift operations:

- 1, 2 or 3 shift with 1 battery
- Opportunity charging and/or overnight charging when possible.

Charging time

~2 hours

Based on 80% charge.

Good for business

Reducing your emission shouldn't come at a cost, it should be beneficial to both the environment and your bottom line.

Kalmar's electric forklift trucks deliver on both accounts. They are just as powerful and efficient as diesel models without producing any harmful carbon emissions. In fact, they produce zero emissions at source, which will help you substantially cut your fuel bills, while improving your environment credentials.

It pays to go electric

With our electrically powered forklift trucks, you will benefit from reduced fuel costs and lower servicing needs, as electric machines have longer service intervals, fewer moving parts and do not require oil or filter changes. All helping to maximise your uptime, and overall cost-effectiveness.

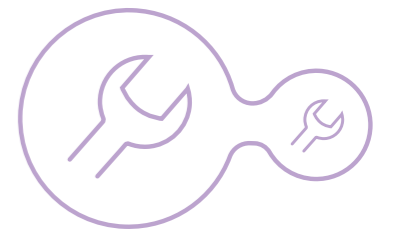

Eco-efficiency at work

Reducing the fuel consumption of your equipment also reduces your emissions, which will enhance your environmental reputation and help you meet current and future emissions standards. Together we can shape the future of cargo handling, with safe and eco-efficient solutions that improve your every move.

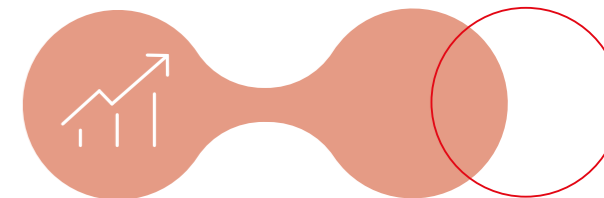
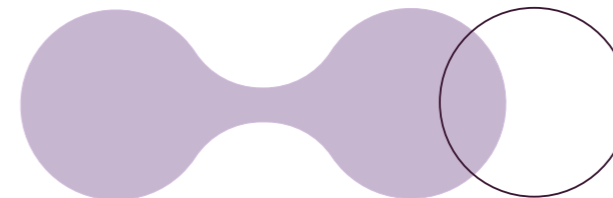

The power is in your hands

By combining three highly efficient AC-motors [two for the traction drive, each individually connected to the left and right wheel gears, and one for the hydraulic pump] all with direct drive, and no transmission you get a powertrain combination that will deliver on power and productivity while producing zero carbon emissions at source.

This electrically powered solution has been designed to offer a sustainable and highly efficient forklift range, with great performance, high productivity and is safe and smooth to operate with minimised energy losses - giving you more running hours on each charge. Regenerative power from the braking system returns power to the batteries, further enhancing the overall efficiency of the system. You just need to choose the optimal battery solution for your operation; Lead Acid or Lithium-ion.

Lead Acid

Kalmar's Lead Acid batteries come fully self-contained and can be charged while fitted to your machine or removed from your forklift and charged in a ventilated charging space. Recharging your Lead Acid batteries normally takes place overnight, if you need to run continuous shifts then you will need to have one set of batteries fitted to your forklift, while the second set charges. Three battery sets would be required for continuous operations across multiple shifts. Lead Acid batteries cannot be opportunity charged during your work cycles.

Battery sizes*

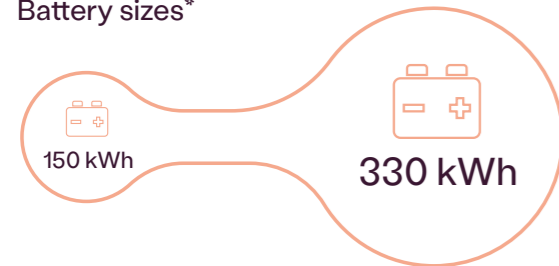

* Battery Sizes: Nominal energy capacity (kWh) = rated capacity (Ah) × voltage (V) / 1000, based on a 5-hour discharge rate (C5)

Lithium-ion

There are two different Lithium-ion batteries available, on the truck wheel base, which can be quickly opportunity charged during operational hours or fully charged overnight.

Battery sizes



Operational intensity and duty cycle - kWh energy consumption

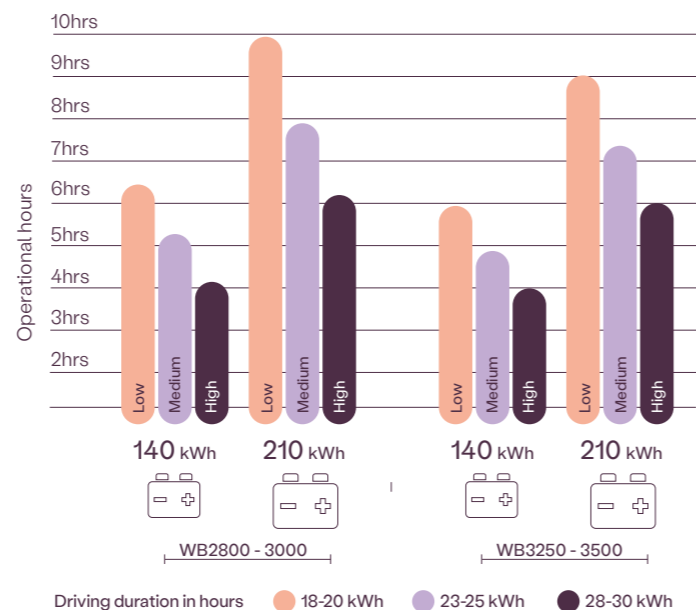

Modular by design

Batteries and chargers are a big part of your overall investment making it critical that you get a solution that is matched to your operational requirements, which is why Kalmar has taken a modular approach to our Lead Acid and Lithium-ion battery and charging solutions.

Kalmar can help you work out which battery option and charging solution is right for your business based on your current work cycles.

There are a number of different charging options available for you to choose from.

*Notes on operational hours per drive cycle:
 - The calculations are based on theoretical assumption of usable battery capacity.
 - This calculation is intended for discussion, may not reflect all applications. Ground conditions, Ambient temp, charging management, etc will impact the potential operating time.
 - The following factors will impact energy consumption:
 1) Frequent high lifting and heavy loads.
 2) Operation in uneven terrain.
 3) Long distances.
 4) High lift capacity machines consume more than low capacity.
 5) ECC continuously running on full effect.

Lead Acid solution:

Charging power



Full charging time

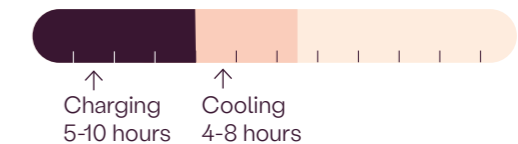

Lithium-ion solution:

Charging power

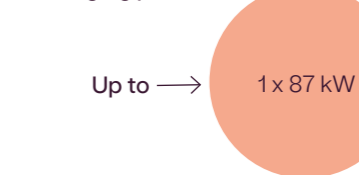

Full charging time

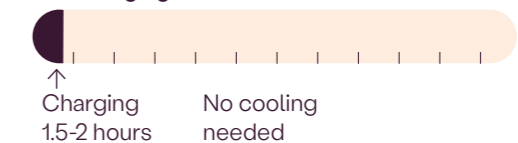



Managing your power

With our Lead Acid solution, the Battery Monitoring Unit [BMU] is mounted to the battery and connected to the battery, charger and cloud. This enables the BMU to monitor the current, voltage, water level, temperature and balance between cells.

For the Lithium-ion solution, the Battery Management System [BMS] is mounted within each battery cell, connecting the battery, charger and cloud. This enables the BMS to manage battery charging and all other important parameters.

While the forklift controller redirects regenerative braking energy back into the battery packs.

Data from the BMU / BMS is displayed in MyKalmar INSIGHT* allowing you to secure optimal battery use to ensure warranty conditions are met and the longest possible lifetime of the battery can be obtained.

Productive in extreme weather conditions

Our electrically powered forklift trucks can run optimally even in extreme weather temperatures: with an optimal operating temperature of 20-30°C.

Thermal Management System**



Extra safe

With any electrically powered high voltage system you need to be extra safe which is why we have encased and shielded all high voltage lines. Should any connection be interrupted, the whole system will automatically shut down keeping your team safe. Knowing how to work with high voltage power sources is extremely important which is why Kalmar has specifically designed a High Voltage training course to enhance the skills of your workers to keep them extra safe.



* MyKalmar INSIGHT access is through a separate subscription agreement.
 ** TMS is only available with Lithium-Ion batteries that include a BMS. Liquid cooling and heating apply to both the battery and cabin, incorporating anti-freeze for temperature control.

Efficient and productive

Buying an electric forklift doesn't mean compromising on power, as electric powertrains provide full torque immediately and are smoother to operate. Making operating cycles shorter, driving up your operational productivity. With extended servicing cycles and improved diagnostic tools your machine will benefit from higher availability rates than the diesel alternatives.

A simpler design



Electric forklifts have less moving parts than diesel models. Without the need to change the starter motor, turbo or fuel filters, servicing and maintenance on the powertrain will take less time and cost up to 50% less. As less parts are required, your parts replacement costs and stock levels will also be substantially reduced.

Optimise your settings



All Kalmar Electric Forklifts have easily adjustable settings from the control panel for:

- acceleration 1-10 (10-100%)
- deceleration 1-10 (10-100%) brake regen.

Reduce energy usage by up to 20%

Kalmar ECO Drive allows you to optimise your truck's performance with three different modes:

Power Mode:

when high performance is required. With full motor power, you will be able to move quickly about, lift and lower at full speed, without compromising on safety.

Normal Mode:

when you need a balance between energy usage and productivity. You can expect slightly lower acceleration and speeds.

Economy Mode:

when you need the most efficient energy usage. With reduced acceleration and speeds - your batteries will run for longer.

Save up to **15%**

Save up to **20%**



Provides full torque immediately for smoother operation.

Designed for the driver



Ergonomically designed

Kalmar Electric Forklifts come fitted with our ergonomically designed EGO cabin. With slim line a-pillars, adjustable seating, steering wheel and control panel, your drivers will benefit from a superior operating environment and visibility.

A healthier work environment

Electric forklifts have always been seen as specialist machines for handling sensitive goods, in fact they deliver many additional benefits:



Less vibrations make handling sensitive goods safer and reduce stress and strain on your operator's body.



Electric forklifts are extremely quiet, making working indoors less disruptive for both operators and by-standers.



As electric forklifts produce no exhaust fumes they are safe to operate inside and where other staff are working or sensitive goods are stored.



More comfortable

With a choice of comfortable driver seats, a fault safe pedal system and powerful Electronic Climate Control system with smarter controls your operator will benefit from improved ventilation heating and cooling, plus a cabin with superior comfort and lowest noise level inside and outside.

Easy to operate

Our electrically powered forklift trucks give you a wide choice electric-servo lifting levers, dual lever joystick or single joystick, an electronically adjustable work console and side tilting steering wheel. All designed to make operating your reachstacker easier and more efficient to operate.

Extra smart

Our intuitive user interface combines visibility, sound and touch to create a perfectly balanced operating environment with an intelligent colour display at its heart. Advanced diagnostics, battery status overview and smart settings allow improved operational control and optimal charging planning.

What do you need to lift?

Choose between a wide range of lifting masts, carriages, forks and attachments. We offer complete solutions whereby we assemble the attachment in the factory and integrate it with the forklift's other functions.

Forestry industries

With our medium electric forklift you will be able to handle most loads indoors or out, including lumber packages, pulp, paper, board and waste. Moving raw materials off trucks or train trays, to moving wood around during the milling process or lifting and moving final goods ready for dispatch.



Metal industry

Our heavy electric powered forklifts can lift, stack and transport metal slabs, blooms and billets or plates, coils, bars and pipes, which is made even easier and safer when you use speciality attachments including magnets, clamps, grippers, coil rams, forks or slings fitted to the lifting equipment. Also raw material supplies and recycling can be handled.



Concrete, energy and heavy industry

Flat, round or bulky concrete sections, wave-breakers, bricks and rocks can be lifted with ease, as can hardware for the energy sector: like supplies for oil & gas offshore sites, or biomass and nuclear plants. Heavy loads for the wind turbines and their sub contractors; producing foundations, mono-piles, tower sections, nacelles, drive units and blades can also be lifted and moved safely and efficiently.



Logistics and stevedoring

Whether you're moving sensitive goods like fresh fruit and vegetables, pallets filled with goods ready for dispatch or moving containers this electric forklift can handle your loads efficiently and safely both indoors and out as it produces no carbon emissions.

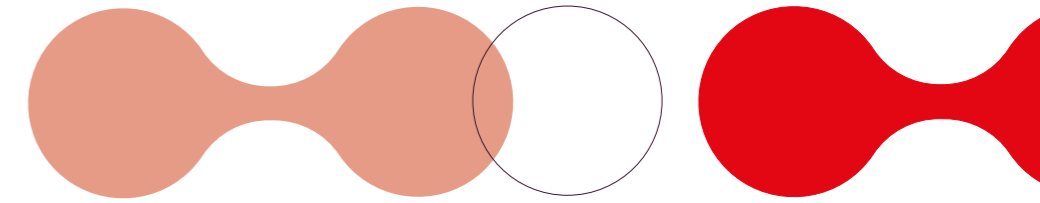

Safety fitted as standard

All Kalmar equipment is compliant with EN 1175:2020.

At Kalmar, the safety of people working with our machines is always at the top of our minds, which is why meeting global safety standards is important to us. The safety standard EN 1175:2020, which sets the electrical and electronic component standards for industrial trucks, has been updated to improve the safety of these machines while in operation. This update is valid from April 2023. All Kalmar counter balanced machines, including reachstackers, empty container handlers and forklifts have been updated to meet this new standard to ensure that working with a Kalmar machine is as safe as it can be.

For Kalmar, the safety of your drivers and maintenance staff is of critical importance, which is why our machines come with many more safety features fitted as standard than other machines available in the market.

The features listed here come fitted as standard on all Kalmar machines. You can enhance your employees' safety further by fitting your machine with our additional safety options listed on the following pages.



2-point seat belt. Ensures that your driver is safe and secure while operating our equipment, all Kalmar machines are equipped with an adjustable 2-point seat belt system.



3-point Contact System. Makes sure your drivers are safe when entering or exiting our equipment. All machines are fitted with steps and handles to ensure they can always maintain three points of contact with the vehicle, helping to prevent any accidents.



Double brake pedals. The right-hand-side brake pedal is intended for emergency braking, particularly useful for operators familiar with traditional automotive controls, allowing the driver to choose which foot to use, providing more flexibility.



Steps with anti-slip protection. To reduce the risk of your driver slipping or falling on our equipment, all entering and exiting points are fitted with non-slip surfaces giving them extra grip, so your drivers stay safe.



Control System. All our equipment is fitted with an electronic Control System for monitoring the machine's different functions while in operation, helping to keep your driver fully informed at all times with up-to-date Operating, Event Controlled and Error Code information.



Operating information. Our equipment's Control System provides several operating information menus, which give your operator and maintenance personnel a great insight into the on-going performance of the machine, allowing them to keep it running optimally.



Event controlled information. Provided through the Overload Protection System to warn the driver through the equipment's Control System if their load exceeds the specified safety limits.



Error code information. Should there be any issue with your equipment while in operation, the electronic control system will immediately alert your driver with the appropriate error code, so they know exactly what is going on and can take appropriate action.



Display. Cabins are fitted with an easy to read display which keeps your drivers fully aware of the machine's on-going performance and any maintenance actions that need to be taken.



Emergency Stop Switch. Manually activated to immediately stop all power transmission and load handling functions in emergencies. Cuts power to both the hydraulic and electric drive systems for safety.



Reverse Camera System. Knowing what is going on behind you is critical when reversing your Kalmar Forklift, which is why they are all fitted with a high-resolution [1080p] cabin display screen and reversing camera.



Operator Presence Detection System. Maintains safety for both the driver and pedestrians, as all our equipment is fitted with an alarm or visual indicator that comes on automatically if:

- The seat belt requirement while driving is not met - seat belt not fastened while in operation
- The driver leaves the driver's seat without engaging the parking brake.

The system includes a buzzer in the cab and visual warning lights.

Additionally, if the driver leaves the seat while the machine is active, the electric drive is shut off and load-handling functions are disabled.



Electric drive protection and warning system. Warning systems designed to protect your machine's driveline in case of higher than expected temperature, are standard on all equipment.



External reverse light. For the safety of others, all our equipment is equipped with external reversing lights that help the driver keep everyone informed that they are moving backwards.



LED lights. These come fitted as standard on all our equipment, providing better visibility when working in reduced light.



Neutral Start Interlock. It prevents the machine from starting unless all drive and load handling controls are in a neutral position. This protects the driveline and ensures there's no unintended movement when powering on the machine



Protection against falling objects. Cabin roof windows on all our equipment are fitted with high strength materials which can withstand heavy blows, helping to protect your drivers from falling objects.



Good visibility. Kalmar cabins provide your drivers with excellent visibility, forwards, upwards, sideways and behind them to help them stay safe while in operation.



Upgrade options

Kalmar has a range of options that make operating your equipment even safer.



Kalmar Safety Cameras and detection solutions. There is a wide range of camera and detection solutions available that will enhance the overall safety of your equipment when in operation. Cameras will extend and enhance the driver's visibility range, improving safety and productivity depending on placement. Top-level options offer surround view, the ability to record the course of events, and alert the driver of pedestrians in the vicinity of the equipment. Adding radar sensors will warn about objects when reversing. You can choose one solution or combine a number together.



Alco-Lock. To ensure your driver is at their best when operating your equipment you can install an Alco-Lock system. This system makes sure that the driver meets alcohol blood level standards before being able to start the machine, much like a breathalyser.



Additional lighting. Extra lighting, particularly if you operate your machine at night, as you can bring greater operational visibility and safety for personnel working on the site. You can choose additional LED working lamps on specific positions.



Reverse Beeper System. When your staff are working side-by-side with moving vehicles there is always a safety risk. Installing a reverse beeper system provides a clear acoustic alert when the machine is reversing so personnel can make sure they stay out of harm's way at all times.



Fire Suppression System. Protect both operator and machine with an integrated Fire Suppression System*. The system uses high-pressure water mist sprayed through multiple nozzles to quickly suppress fires detected via an in-cabin temperature sensor or manual activation. Additionally, for electric-driven models include a parallel gas-based system using Novec™ to safely extinguish fires in the electric compartment, ensuring comprehensive protection for high-voltage components.



Additional camera. To make sure your driver always has a clear view even when fully laden you can choose to have an additional 130o camera mounted on the lower beam of the mast carriage.

Kalmar has a range of solutions that will help make your equipment more eco-efficient and sustainable.



Tyre Pressure Monitoring System. Helps to reduce wear and tear on tyres which results in reduced fuel consumption. Bluetooth sensors keep the driver advised of the condition of the tyres continually. Active care of your tyres can result in a 10-40% increase in tyre life.

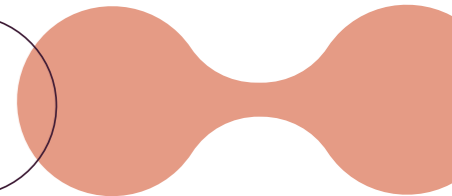
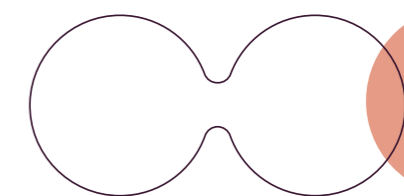
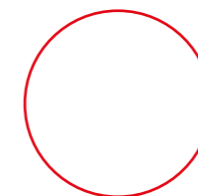

* Not suitable for electrical fires.



Keep moving with Kalmar Services

To keep your business moving Kalmar Services offers a range of services that can help you keep your equipment moving optimally.

Kalmar Care

Care that keeps your business moving.

With Kalmar Care you get a flexible service that's built around your business. Including, the experience and knowledge of Kalmar's dedicated staff, coupled with transparency and increased predictability of costs.

Kalmar Care is available in three different service models: our two customisable contracts – Essential Care and Complete Care – and our flexible solution On Demand Care.

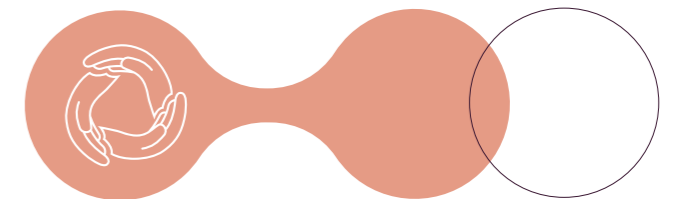

Service models:



Essential Care

A maintenance solution to keep your equipment in an optimal condition.



Complete Care

A complete service solution providing piece of mind and maximum equipment uptime.



On Demand Care

Top-of-the-line service whenever you need it.

Maintenance Planning	●	●
Preventive Maintenance	●	●
Predictive Maintenance		●
Corrective Maintenance		●
Preventive Spare Parts	●	●
Corrective Spare Parts		●
Lubricants	●	●
MyKalmar	●	●
MyKalmar INSIGHT	●	●
Tyre Maintenance		●
Battery Maintenance		●

● Included ● Optional

Top-of-the-line service whenever you need it

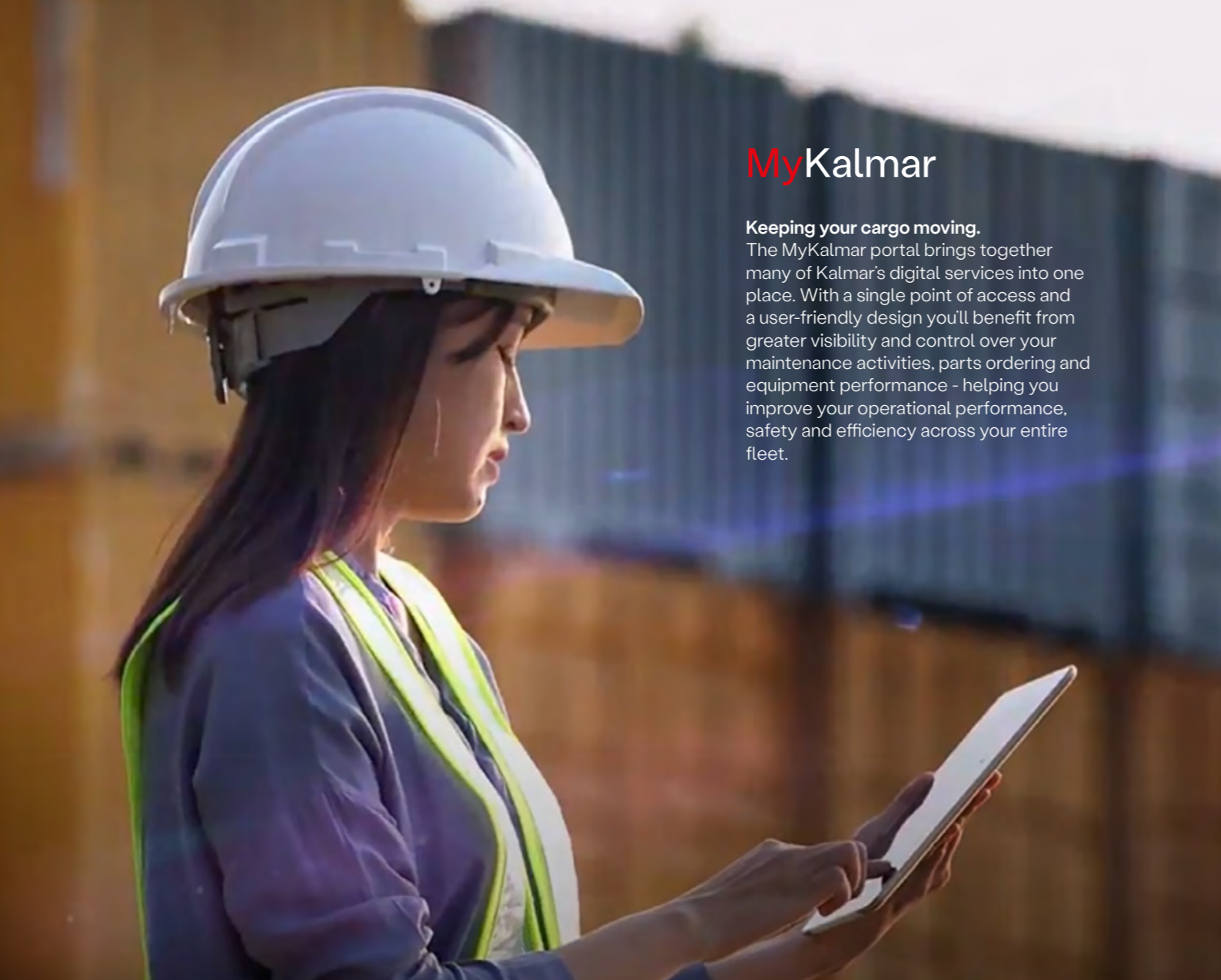

MyKalmar

Keeping your cargo moving.

The MyKalmar portal brings together many of Kalmar's digital services into one place. With a single point of access and a user-friendly design you'll benefit from greater visibility and control over your maintenance activities, parts ordering and equipment performance - helping you improve your operational performance, safety and efficiency across your entire fleet.

MyKalmar INSIGHT

Optimise your operations with Insight.

MyKalmar INSIGHT* is a performance management tool for cargo handling, which gives you an easy to use overview of your fleet operations, by aggregating data from multiple sources, including equipment built by other manufacturers. Review your entire fleet activities, schedule maintenance activities and order the required parts

automatically. All enabling you to take action on real-time information, that will help improve your overall operations immediately. MyKalmar INSIGHT comes fitted and ready to be activated in all new Kalmar equipment, it can also be retrofitted into existing Kalmar equipment or those built by other manufacturers.



*Installation costs and/or an annual subscription fee may apply.

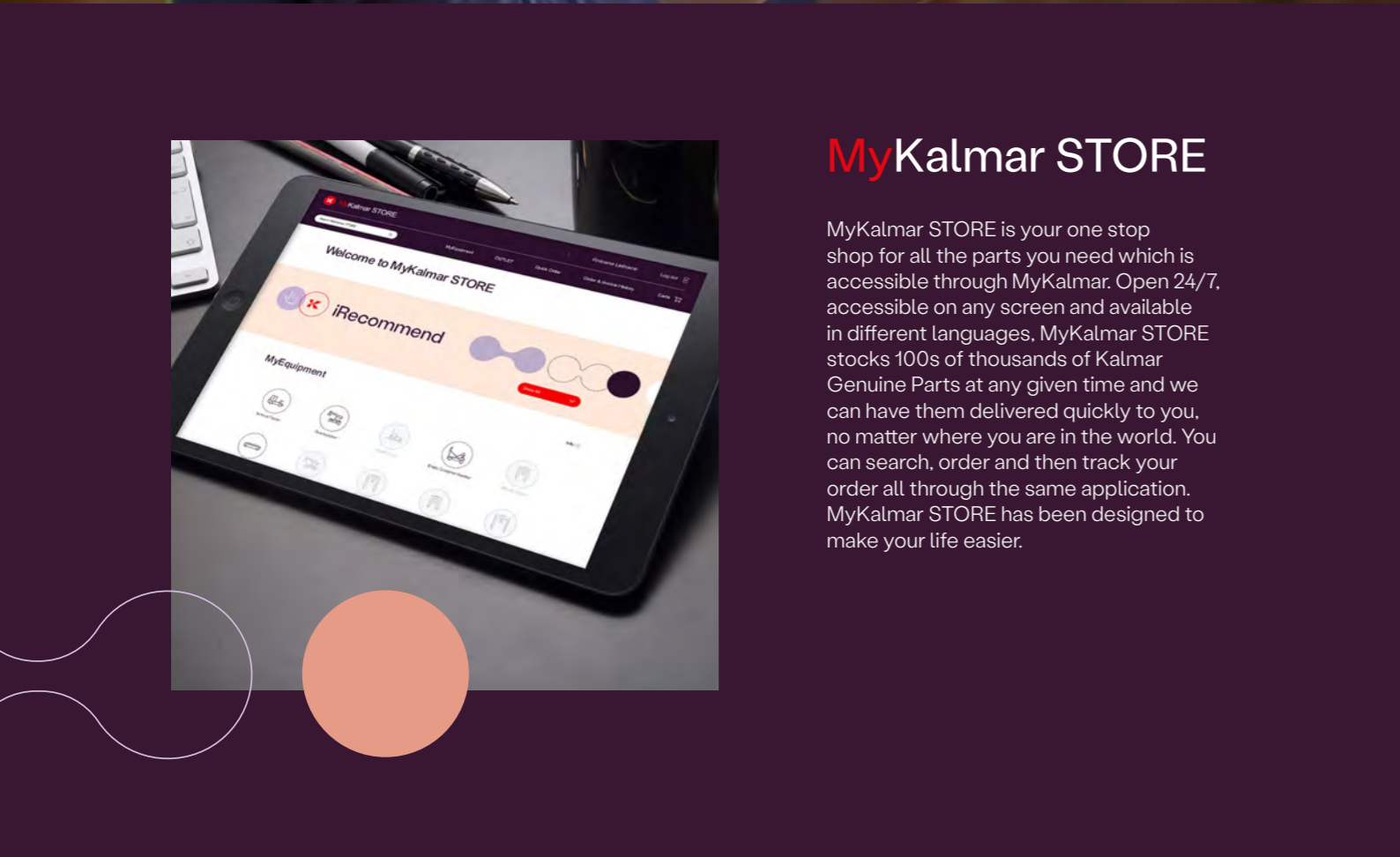

MyKalmar STORE

MyKalmar STORE is your one stop shop for all the parts you need which is accessible through MyKalmar. Open 24/7, accessible on any screen and available in different languages, MyKalmar STORE stocks 100s of thousands of Kalmar Genuine Parts at any given time and we can have them delivered quickly to you, no matter where you are in the world. You can search, order and then track your order all through the same application. MyKalmar STORE has been designed to make your life easier.

Kalmar Training

Enhance your skills.

To get the most out of your new machine our training centre offers a range of courses for both your technicians and operators. Operators can be taught how to drive the machine for optimum performance and minimum waste, and to learn what needs to be checked daily for optimal safety. Technicians can be educated with the knowledge they need to keep your new equipment in top condition in a safe way. Courses are a mix of theory and hands-on experience.



Standard

Norms Standards and Regulations

- Machinery Directive 2006/42/EC
- Safety Industrial Trucks Standard ISO 3691-1 + EN 16307-1
- Safety Low & High Lift Trucks Standard ANSI / ITSDF B56.1
- Stability Masted Forklift Trucks Standard ISO 22915-1,-2
- Electrics / Electronics Standard EN 1175
- Electromagnetic Compatibility Directive 2014/30/EC
- Electromagnetic Compatibility Standard EN 12895
- Noise Emission Directive 2000/14/EC and 2005/88/EC
- Noise Emission Standard EN 12053
- CE-marking (EU/EEA)
- ANSI / ITSDF-marking Forklift Trucks (USA/CAN)
- AS-marking (Australia)
- UKCA-marking (UK)
- Supply of Machinery (Safety) Regulations 2008 (UK)

Chassis

- Strong, durable and welded C-profile heavy-duty chassis
- Powerful front end for drive axle and lift mast fixations
- Solid tilt cylinder fixations in chassis and mast
- Full access to the entire powertrain with tilting cabin
- Easy access to battery, power distribution and connections
- Very good visibility - forward, up, sideways and rearwards
- Low cabin mounting for easy access on both sides
- Lifting eyes and achor points (front & rear)
- owing pin through rear counter weight (long handle)

Body

- Strong and protective steel mudguards (front / rear)
- Cabin entrance on both sides with dual side doors
- Dual access stairways on right sides (steps/handles)
- Long bottom step between the mudguards (anti-slip)
- Short access steps (2x) up to the cabin (anti-slip)
- Lamp brackets on front mudguards (2x)
- Basic noise insulation kit of the forklift

Steer Axle (Rear)

- Kalmar steer axle mounted dual pivot bearings
- Steer axle with mechanical side stops
- El-servo power steering with double acting cylinder
- Steer axle with narrow turning radius
- Steer links of "dog-bone type" (easy-to-change)
- Steer angle sensors for safe steering at all speeds

Drive Axle (Front)

- Kessler D81 drive axle dual inputs and hub reductions
- Drive motor & steer angle sensors for electronic differential
- Maintenance-free oil-cooled Wet Disc Brakes (WDB)
- Dual parking brake, spring loaded with hydraulic release
- High pressure filter (10 µm) for the brakes
- ECG90-6 to 140-6: width over tyres = 2500 mm
- ECG100-12 to 180-6: width over tyres = 2540 mm

Wheels (Tyres and Rims)

- Same dimension on drive and steer tyres and rims.
- Various brands of diagonal, radial and super-elastic tyres.
- ECG90-120: rim 8,00x20" / diagonal tyre 11.00x20"
- ECG127-160: rim 8,00x20" / diagonal tyre 12.00x20"
- ECG180-6(5S): rim 8,5x20" / radial tyre 12.00R20"

Powertrain

- Schabmüller electric asynchron AC-motors (3-phase)
- Dual drive motors (2 x 37 kW) with electric fan cooling
- Dual pump motors (2 x 50 kW) with electric fan cooling
- Single electric air-cooled brake pump motor (1 x 2.5 kW)
- Re-generative brake system / energy back to battery
- Electric cooling fans for drive, pump and brake inverters
- Electric motors are protected inside the chassis

Power Electrics (120V)

- Electric power system voltage 120V
- Power cabinet mounted on chassis
- Dual power cables with REMA-640 connectors (LA)
- Dual power cables with REMA-640 connectors (LI)
- Electric cabinet mounted on chassis with main parts (LHS)
- Charging standards dual REMA-640 charging plugs (LA)

Battery (Lead-Acid)

- Robust and proven technology, up to 1400 cycles
- Rear steel structure that protect the battery unit
- Ventilated charging cycle with efficiency 70-80%
- Automatic central water topping system for battery cells

- Regular maintenance needed (electrolyte, voltage, cleaning)
- Battery Monitoring Unit (BMU), mounted and connected
- Charging power: 13 - 28 kW per unit (2 chargers)
- Charger power supply: 2x32A or 2x63A (2 chargers - 400V/3P/NE)
- Chargers: acid-circulation or pulse charging and BMU
- Typical battery cycle: drive 8h, charge 8h and cool-down 8h (1-shift).
- Charging: full charge 7-8 h

Battery (Lithium-ion)

- High capacity LFP-technology, 4000-5000 cycles
- Lithium-ion integral battery unit, with BMS, with TMS
- Rear steel structure that protect the battery unit
- Maintenance-free, need equal-charging, efficiency 90-95%
- Battery Management System (BMS) with CanBus
- Battery TMS with active cooling and heating
- Charging power: up to 87 kW per unit (1 charger)

Thermal Management System (Lithium-ion)

- Battery Management System (BMS) with CanBus
- Smart controls of cooling and heating units
- Active cooling unit (AC compressor)
- Heating unit mounted on the battery cells
- Power limitation functions to optimise consumption
- Limp home function at low SOC (speed 8 km/h)

Hydraulics

- Power-on-demand, with high lifting and carriage speeds
- Parker fixed piston pumps (2x)
- Fixed pump for brake oil pressure / accumulator (1x)
- Pressure filters for hydraulics / brakes (2x/10 µm)
- Power steering, power brakes and ORFS-couplings
- Hydraulic tank with breath filter and level glass (220 lit)
- Main control valve, steering valve and accumulator

Lift Mast

- Large selection of mast types and lifting heights.
- Duplex Standard; 2-stage mast, with free-visibility
- Strong, durable mast design (pair of cylinders/chains)
- Heavy-duty mast profiles and strong cross members
- Mast with strong mast wheels, bearings & guide rollers
- Large shafts-bearing for mast, strong tilt fixation
- Mast tilt angles +5 / -10 deg (FW / BW)

Fork Carriage

- Carriage with strong wheels, bearings & guide rollers
- Widths: 2450 mm (90-140) / 2500 mm (100-180)

Forks

- A range of fork sizes and five cross-section options are offered as standard. For full details, refer to technical specifications
- Fork mountings of roller-type
- Tapering: Standard 0-200 mm full thickness (fork length is 1600 mm or shorter)
- Tapering: Standard 0-600 mm full thickness (fork length above 1600 - 2400 mm)
- Tapering: Standard 0-1200 mm full thickness (fork length above 2400 mm)

Electrical System (24V)

- DC/DC Converter 120/24V
- Electric cabinet, mounted behind driver
- 2 LED working lights on front mudguards (main beam)
- 2 LED working lights on mast (first cross member)
- 2 LED reverse lights on rear cabin roof
- 4 directional blinker lights (front / rear)
- 2 tail / 2 brake LED-lights rear in counter weight
- The tail / brake lights are flashing when reversing
- Reverse camera: full HD, wide angle, IR night light)
- Monitor: 7", full HD, colour, RAM-mounted on RHS

Cabin EGO

- Structure**
- Spacious, modern cabin with great ergonomy level
- Strong profiles, pillars and cross members
- FOPS certified drivers cabin (Falling Object Protection Structure)
- Tilttable cabin with full access to powertrain & hydraulics
- Large window sections with great visibility in all directions
- Large access doors with air-damper & key-lock
- Doors: sliding windows + access handles
- Comfort**
- Drivers seat, mech. spring suspension, high back
- Comfort seat, adjustable, sensor & 2-point belt
- Electric adjustable work console (up-down/fw-rev)
- Work console: lift levers, controls, lamp buttons etc
- Inside rear view mirrors (left + right side)

- Interior lights with fade away function
- Fully adjustable steering wheel incl tilt function
- Power steering wheel with steer knob

Controls

- Electric levers / joystick for mast, tilt & forks
- Auto rev-up accelerator at lifting / tilting / fork position
- Electric accelerator pedal (hanging)
- Double brake pedals (L + R)
- Button for electronic hand brake (on/off)
- Safety override for hydraulic functions (by switch)
- Multi-function lever LHS (parking brake/travel direction switch)
- Combined horn and blinker lever
- Warning - hand brake (on/off) leaving seat

Climate

- ECHV, electronic controlled heating & ventilation
- Powerful cab heater, power 6.0 kW (20,500 Btu)
- Strong cooling unit, power 14.0 kW (47,700 Btu)
- High-capacity ventilation unit - max air flow 483 m3/h
- Multiple individual blowers (8x upwards / 2x downwards)
- Fresh air and recirculation filter (replaceable)
- Double wipers / washers on front window (larger area)
- Single wipers / washers on roof and rear windows
- Interval wiper functions on front, roof and rear windows

Indicator lamps

- Direction indication (blinkers)
- Parking brake

Eco Drive Modes (EDM)

- Performance mode settings: Power - Normal - Eco

Information Systems

- Kalmar CanBus controls with 4,3" monitor
- Danfoss controls DM430E in RAM mount
- Menu controller with toggle wheel & push buttons
- Programmable settings and full monitoring of all main systems

Accelerator / Brake Settings:

- Programmable accelerator power in 10 steps (1-10)
- Accelerator: from soft to fast (low to high energy)
- Programmable brake re-generation power in 10 steps (1-10)
- Brake regeneration; feed energy back to the battery

Operator menu:

- System voltage
- Travelling speed (km/h or mph)
- Combined hydraulic and brake oil temperature
- Clock and date
- Operating time (hour meter)
- Service time indicator (hours)
- Status of heating system & AC system
- Estimated time before empty battery (hour/min)
- Service indicator
- Trip computer / statistics
- Various warning lights & signals:**
- Charging battery
- Safety system disconnected
- Failure indicator
- Low brake oil pressure
- Low coolant level battery
- Low coolant level electrical components
- High coolant temp battery
- High coolant temp electric components
- Low power battery volt level
- Low/high battery cell temp
- Low/high battery cell volt level unbalanced power battery
- Hydraulic and brake oil temperature
- Low washer fluid level

Fleet Management

- Equipped with telemetric hardware for MyKalmar INSIGHT.

Colour

- Chassis, tanks & mudguards: Red RAL 3000
- Mast, carriages, forks and axles: Black RAL 7021
- Cabin: Iron-Grey RAL 7011
- Rims: Silver-grey, RAL 9006

Documentation & Decals

- Load chart diagram inside cabin
- Machine data sign on chassis (LHS) including load chart
- Warning, tyre pressure & oil pressure stickers
- Lift lever / joystick and function stickers in cabin
- Fuse diagram
- Instruction manual
- Maintenance manual
- Spare parts catalogue

Standard Warranty

- Warranty electric Forklift:12 months / 2,000 hours
- Warranty battery Lead-Acid (Europe): 36 months / single shift / 750 D.C.
- Warranty battery Lithium-ion: (TBA)

Options

Chassis/Body

- Models with standard and short wheelbases
- Anti-slip strips: mudguards, tanks & lamp brackets
- Wheelbase 3.750 mm
- Extra mud flaps (front and rear)
- Steel grid protections for light: fender, mast & rear
- Stacking box for wood stick (LHS or rear)
- Additional Stacking box for wood stick (LHS or rear)

Wheels (Tyres and Rims)

- Spare wheels, tyres and rims of various brands
- Diagonal and radial tyres of well known brands
- Radials: Continental RT20 and Michelin XZM
- Super-elastic (CSE); Soli-Deal CSE
- Other brands up on request

Battery (Lead Acid)

- Lead-Acid batteries (2x), with trays & lids, rear mounted
- Battery Capacities: 1240 - 2408 Ah (150 - 330 kWh)
- 1-shift: 1 battery set (2 batteries + 2 chargers)
- 2-shift: 2 battery set (4 batteries + 2-4 chargers)
- 3-shift: 3 battery set (6 batteries + 2-4 chargers)
- Quick-change battery fork pockets on battery tray (available with battery pallet)
- Battery combinations depending on energy consumption
- Chargers: acid-circulation or pulse charging

Battery (Lithium-ion)

- Battery Capacities: 140 / 210 kWh
- High-power Lithium-ion chargers with CanBus

Hydraulics

- Extra hydraulic function including hoses (per function)
- Push-button hydraulic function via magnet valve
- Quick release couplings "aerogrip" 1/2" (per function)
- Individual fork positioning including 5th hydraulic function
- Hydraulic accumulator for lifting funiton
- Hydraulic accumulator for lifting function "auto on/off"
- Hydraulic oil cooler unit (on RHS)
- Mast tilt angles: FW +11 / BW -8 deg (19 deg)
- Mast tilt angles: FW +14 / BW -11 deg (25 deg)
- Functions for attachments (paper, steel, precast)

Lifting Mast

- Duplex Standard (no FL); lift heights 3.00 - 7.00 m
- Duplex Freelift (full FL); lift heights 3.00 - 7.00 m
- Triplex Freelift (full FL); lift heights 4.50 - 7.00 m
- Duplex Heavy-Duty (no FL); lift heights 4.00 - 6.00 m
- Other lift heights / closed heights upon request

Fork Carriage

- Fixed carriage: manual moving forks (width 2.50 m)
- Sideshift carriage: manual moving forks (width 2.50 m)
- Sideshift/fork positioning: (width 2.50 / 2.95 / 3.45 m)
- Sideshift/fork position: pin-type (width 2.50 m)
- Sideshift/fork position + center levelling: (width 2.50 m)
- Attachments: carriage sides, chain brackets & hoses
- Attachment of various brands for factory integration

Forks

- See fork dimensions under Specifications
- Wide variety of fork lengths, mounting, and tapering
- Fork Shaft System; hook-on type / forks, coil ram or attachment
- Fork Shaft System; pin-type / forks, coil ram or attachment
- Kissing forks with chamfer inside/outside (integral roller-type)
- Kissing forks with chamfer inside/outside (FSS hook-on type)
- Hydraulic levelling fork (up/down) on left fork or / and right fork

Electrical System (24V)

- Tuner FM-AM, RDS, MP3, USB, Bluetooth, Stream
- Tuner FM-AM, RDS, MP3, USB, Bluetooth, Stream / DAB
- Power sockets: 2x24V and 2x12V (in door columns)
- Power sockets: 2x24V / 1x12V / 2xUSB 5V
- Electric air pressure horn
- Reverse alarm (beeping or white noise - multi frequency)
- Protection against chain slack (electronics)
- Mast with automatic vertical function (auto-tilt)

Lamps

- 2 extra LED working lights - in mast (FW)
- 2 extra LED working lights - rear on cabin (FW)
- 4 extra LED working lights - rear on cabin (mix)
- 6 extra LED working lights - rear on cabin (mix)
- 2 extra LED working lights - front on cabin roof
- 1 extra LED working lights - between tilt cylinder
- 2 high/low beam Halogen working lights (repl LED)
- 1 LED rotating warning beacon (on adjustable pole LHS)
- Blue safety light, rearward (when reversing) or forward
- Red safety light, rearward (when reversing) or forward
- Red safety zone light, Left and Right direction
- Rotating beacon LED, activated via reverse gear

Safety functions

- Overload indication for lift/tilt incl. speed restriction
- Speed limitation; default 15 km/h (set by technician)
- Speed limitation at specified load (set by technician)
- Speed limitation at specified lift height (set by techn.)
- Speed restriction set by customer in display: default 15 km/hv
- Tyre pressure monitoring system (TPMS / Bluetooth)
- Alcolock Draeger in cabin

Cabin EGO

- Structure**
- Globetrotter cabin +200 mm higher, roof 12 mm (repl 6 mm)
- Elevated cabin 300 mm
- Rotatable Driver Seat, electric 180 deg (to the left)
- Turnable Driver Seat, manual 55 deg (to the right)
- Steel grid protection for front window
- Steel grid protection for roof window
- Door opening holder (left side and / or right side)
- Flat front window with steel profiles, tinted and laminated
- Roof window 12 mm (repl standard 6 mm)
- Electric cabin tilt pump (up/down)
- Electric heated mirrors, front fender/standard pos
- External cabin reverse mirrors (2x)
- External cabin reverse mirrors (2x) with heating
- Electric heated + adjustable mirrors, front mudguard

Comfort

- Air cushioned driver seat with horizontal suspension
- 3-point seat belt
- Extended seat backrest
- Headrest for driver's seat
- Armrest adjustable left side
- Seat heating
- Seat cover in vinyl
- Leather reinforced seat, high backrest, 3-point belt and heating
- Grammer Actimo XL, air cushion, heating, high back, 2-point belt
- BE-GE 3700, air cushion, heating, high back, 2-point belt, leather reinforced seat
- Isringhausen 6830KA/880, air cushion, heating, high back, 2-point belt
- Extra trainer seat incl. 2-point belt
- Bracket for terminal and monitor (RHS)

Controls

- Travel direction button on 1st lift lever (F-N-R)
- Electronic joystick (EGO)
- Electronic lever steering (without feedback)
- Electronic mini-wheel steering
- Search light maneuverable via remote control

Indicator lamps:

- Head beam

Climate

- ECC, electronic heating, cooling (AC) & ventilation
- Tinted windows including laminated front window
- Sun visors front, roof and rear windows

Additional Equipment

- Enhanced Safety Package
 - Speed limitation default 15 km/h or free (set by technician)
 - Blue safety light backwards via back alarm
 - Rear warning radar (for reverse camera/monitor in cabin)
 - Seat belt interlock (active before driving - seatbelt on)
- Semi-automatic fire suppression system (DAFO Forrex)
- Fire extinguisher 6 kg, powder (LHS / behind foot steps)
- Central greasing system (14-18-24 grease points)
- Tilt indicator of mechanical type
- Tilt indicator of electronic type (in display)
- Electronic weight indicator in cabin control monitor
- Heat protection kit (incl hoses)
- Heat protection mechanical kit
- Wheelnut protection
- Additional equipment for roadtraffic (LGF-sign)

Camera safety

- Reverse camera with 7" single view monitor
- Reverse camera with 7" split view monitor
- Reverse camera with 10" split view monitor
- Forward camera Mast/Carriage - to cab monitor
- Radar sensors for object detection rearward with/ without connection box
- DVR recorder, up to 4 channels, with SD-card (128 GB)
- Modular full HD solutions (1920x1080p)
- 360° camera system with Pedestrian detection
- Forward-directed 130° Camera mounted in carriage (lower beam)

Information Systems

- VDI - Vehicle Data Interface
- With EDM you can optimise productivity, performance and operational time

Fleet Management (MyKalmar INSIGHT)

- MyKalmar INSIGHT licence (only certified countries)
- MyKalmar INSIGHT Driver Monitor (RFID reader + 10 driver tags)
- MyKalmar INSIGHT extra driver tags (10 tags)

Colour

- Other RAL colour than standard, chassis
- Special and multiple colours, chassis
- Other colour than standard, striping foil
- Reinforced anti-corrosion protection

Documentation & Decals

- Extra set of documentation
- Workshop manuals
- Load chart lbs/inch in cab & sign "no riders"
- Documentation on memory stick

Training

- Training packages (driver, service, maintenance, software)
- Contact Kalmar Training Centre for more information

Warranty

- Additional warranty packages available:
 - Gold (complete forklift): max 5 yr/10,000h
 - Silver (drive line): max 8 yr/16,000h
 - Bronze (structural parts): max 10 yr/20,000h
 - Cobalt (battery + charger): up to 8 yr/16,000h*
- Contact Kalmar for more information

^[1] * Depending on battery technology and brands

Performance

Models			ECG90-6		ECG127-6		ECG150-6		ECG160-9			
SPEEDS	Description	Unit	ECG100-6	ECG120-6	ECG140-6S	ECG140-6	ECG100-12	ECG120-12	ECG150-6S	ECG160-6	ECG180-6	ECG150-12
			ECG100-12S	ECG120-12S	ECG160-6S	ECG160-9S	ECG180-6S	ECG160-12				
SPEEDS	Travel speed, forward - reverse	Unloaded	25 - 25		25 - 25		25 - 25		25 - 25		25 - 25	
		At rated load	25 - 25		25 - 25		25 - 25		25 - 25		25 - 25	
	Lifting speed	Unloaded	0,55	0,45	0,45		0,35		0,35		0,35	
		At 70% of rated load	0,50	0,40	0,40		0,35		0,35		0,35	
Lowering speed	Unloaded	0,40		0,40		0,40		0,40		0,40		
	At rated load	0,40		0,40		0,40		0,40		0,40		
POWER	Gradeability, max	Unloaded	32	32	30	27	26	24	26	24	23	22
		At rated load	21	19	17	16	17	16	15	14	14	13
	Gradeability, at 5 km/h	Unloaded	28	28	26	24	23	21	23	21	20	20
		At rated load	18	17	15	14	15	14	13	12	12	11
Drawbar pull		56	56	53	53	53	53	53	53	53	53	
SOUND	Noise level, inside EGO cabin	EN12053, L _{pAZ}	69		69		69		69		69	
	Noise level, outside	EN12053, L _{WAZ}	100		100		100		100		100	
	Noise level, outside	2000/14/EC, L _{WAZ}	104		104		104		104		104	

Powertrain

Models			ECG90-6		ECG127-6		ECG140-6		ECG150-6		ECG160-9S		ECG150-12		ECG160-12	
ELECTRIC POWERTRAIN	Description	Unit	ECG100-6	ECG120-6	ECG140-6S	ECG140-6	ECG150-6	ECG100-12	ECG120-12	ECG160-6	ECG180-6S	ECG160-9	ECG150-12	ECG160-12		
			ECG120-6	ECG150-6S	ECG160-6S	ECG120-12S	ECG160-6	ECG180-6S	ECG160-9	ECG180-6						
			Wheelbase	mm	2800		2800		3000		3250		3500			
Motor, manufacturer		Schabmüller Germany		Schabmüller Germany		Schabmüller Germany		Schabmüller Germany		Schabmüller Germany						
Motor, type / model / active cooling		AC motor / asynchronous / air-cooled		AC motor / asynchronous / air-cooled		AC motor / asynchronous / air-cooled		AC motor / asynchronous / air-cooled		AC motor / asynchronous / air-cooled						
Motor, speed control type / number of steps		High frequency MOSFET / Stepless		High frequency MOSFET / Stepless		High frequency MOSFET / Stepless		High frequency MOSFET / Stepless		High frequency MOSFET / Stepless						
Output power - drive motor (at duty class)	kW	2 x 37 kW (S2 60 min) / with air cooling		2 x 37 kW (S2 60 min) / with air cooling		2 x 37 kW (S2 60 min) / with air cooling		2 x 37 kW (S2 60 min) / with air cooling		2 x 37 kW (S2 60 min) / with cooling						
Output power - pump motor (at duty class) intermittent	kW	2 x 50 kW (S3 15%) / with air cooling		2 x 50 kW (S3 15%) / with air cooling		2 x 50 kW (S3 15%) / with air cooling		2 x 50 kW (S3 15%) / with air cooling		2 x 50 kW (S3 15%) / with cooling						
Output power - brake motor (at duty class) intermittent	kW	1 x 2,5 kW (S1) / no cooling		1 x 2,5 kW (S1) / no cooling		1 x 2,5 kW (S1) / no cooling		1 x 2,5 kW (S1) / no cooling		1 x 2,5 kW (S1) / no cooling						
Regenerative brake function		Yes / charging of battery		Yes / charging of battery		Yes / charging of battery		Yes / charging of battery		Yes / charging of battery						
Acceleration settings / power programming		In 10 steps (1 - 10)		In 10 steps (1 - 10)		In 10 steps (1 - 10)		In 10 steps (1 - 10)		In 10 steps (1 - 10)						
Retardation settings / brake programming		In 10 steps (1 - 10)		In 10 steps (1 - 10)		In 10 steps (1 - 10)		In 10 steps (1 - 10)		In 10 steps (1 - 10)						
Energy consumption ¹ , normal driving, average values	kWh/h	Lower: 18 / Medium: 23 / Higher: 28		Lower: 18 / Medium: 23 / Higher: 28		Lower: 18 / Medium: 23 / Higher: 28		Lower: 18 / Medium: 23 / Higher: 28		Lower: 20 / Medium: 25 / Higher: 30						
Battery technology type / number of units		Lead-Acid / 2+2		Lead-Acid / 2+2		Lead-Acid / 2+2		Lead-Acid / 2+2		Lead-Acid / 2+2		Lead-Acid / 2+2				
Battery Voltage / rated capacity at 5h (min-max) ²	V / Ah	120 / 1240 - 1376		120 / 1240 - 1376		120 / 1550 - 1720		120 / 1860 - 2064		120 / 2170 - 2408						
Battery nominal enegy capacity (min-max) ³	kWh	149 - 165		149 - 165		186 - 206		223 - 248		260 - 289						
Battery weight, min-max (per battery)	kg	2300 - 2600		2300 - 2600		2800 - 3100		3300 - 3600		3800 - 4200						
Battery dimensions (W x H x L)	mm	1638 x 780 x 718		1638 x 780 x 718		1638 x 780 x 862		1638 x 780 x 998		1638 x 780 x 1150						
Charging power, min / max (per charger)	kW	13 / 14		13 / 14		13 / 14		21 / 26		26 / 28						
Charging power supply ³ (per charger)	A	1 x CCE 32		1 x CCE 32		1 x CCE 32		1 x CCE 63		1 x CCE 63						
Charger / battery connector, type - size		REMA-640		REMA-640		REMA-640		REMA-640		REMA-640						
Battery technology type / number of units		Lithium-ion (LFP) integral / 4 units - 6 units		Lithium-ion (LFP) integral / 4 units - 6 units		Lithium-ion (LFP) integral / 4 units - 6 units		Lithium-ion (LFP) integral / 4 units - 6 units		Lithium-ion (LFP) integral / 4 units - 6 units						
Battery voltage / nominal energy capacity (min-max)	V / kWh	120 / 140 - 210		120 / 140 - 210		120 / 140 - 210		120 / 140 - 210		120 / 140 - 210						
Battery useable energy capacity (min-max)	kWh	119 - 178		119 - 178		119 - 178		119 - 178		119 - 178						
Charging power, max	kW	87		87		87		87		87						
Charging power supply ⁴	A	4 x CCE 63		4 x CCE 63		4 x CCE 63		4 x CCE 63		4 x CCE 63						
Charger / battery connector, type - size - amount		REMA-640 (2x)		REMA-640 (2x)		REMA-640 (2x)		REMA-640 (2x)		REMA-640 (2x)						

Notes:

1. Energy consumption based on duty cycles (intensity): Lower duty / Medium duty / Higher duty
2. Min - Max according to selectible battery option. Actual capacity may vary depending on discharge rate, temperature, and operating conditions.
3. Battery nominal energy capacity (kWh) = rated capacity (Ah) × voltage (V) / 1000, based on a 5-hour discharge rat (C5)
4. Battery / charger: multiple brands and performances. Power supply: voltage 380-440 V / 3-phase + NE / 50-60 Hz

Load diagram

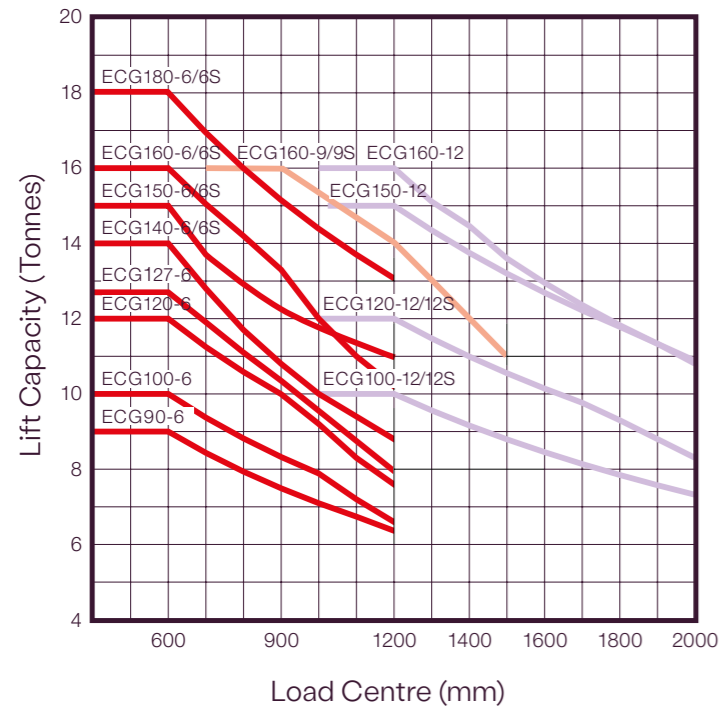

The Load Diagram shows the capacity without considering standard for limitations at longer load centres.

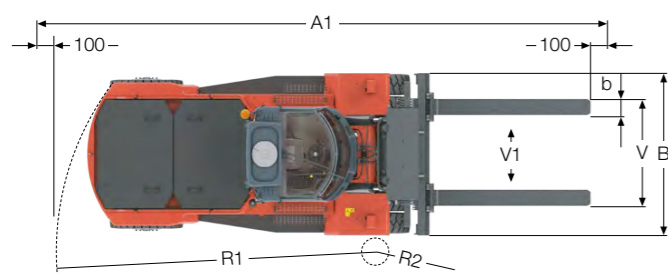
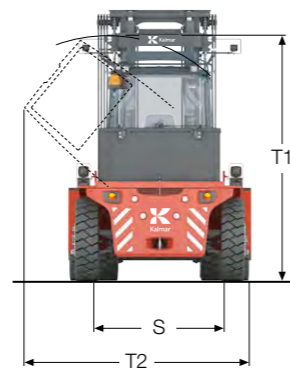
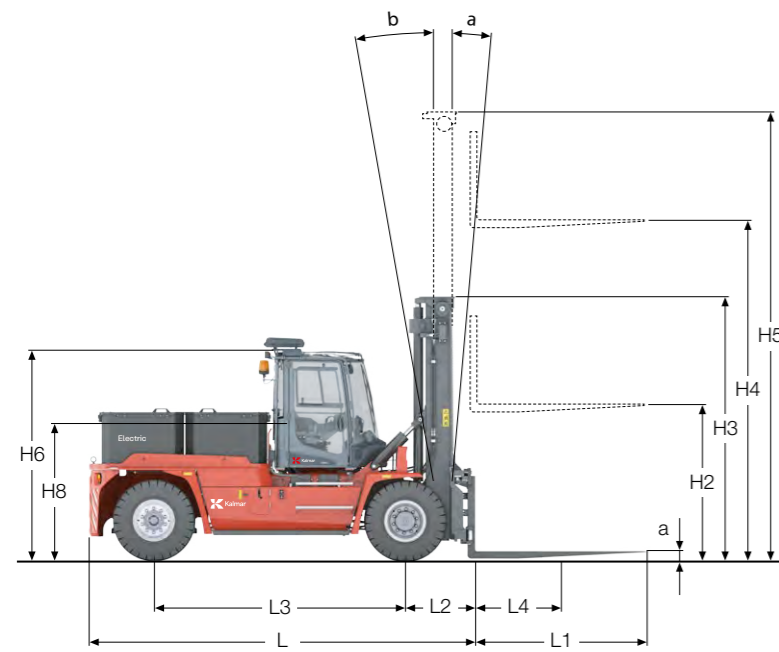

Information correct at time of publication and is subject to change.



Lifting data*

DUPLEX STANDARD (2-stage)	ECG90-140				ECG100-180			
	Lift height	Mast height		Free lift	Lift height	Mast height		Free lift
	H4	H3 min	H5 max	H2	H4	H3 min	H5 max	H2
	3000	3015	4515	-	3000	3195	4695	-
3250	3140	4765	-	3250	3320	4945	-	
3500	3265	5015	-	3500	3445	5195	-	
3750	3390	5265	-	3750	3570	5445	-	
4000	3515	5515	-	4000	3695	5695	-	
4500	3765	6015	-	4500	3945	6195	-	
5000	4015	6515	-	5000	4195	6695	-	
5500	4265	7015	-	5500	4445	7195	-	
6000	4515	7515	-	6000	4695	7695	-	
6500	4765	8015	-	6500	4945	8195	-	
7000	5015	8515	-	7000	5195	8695	-	

DUPLEX FREE LIFT (2-stage)	CG90-140				ECG100-180			
	Lift height	Mast height		Free lift	Lift height	Mast height		Free lift
	H4	H3 min	H5 max	H2	H4	H3 min	H5 max	H2
	3000	3015	4515	1500	3000	3195	4695	1500
3250	3140	4765	1625	3250	3320	4945	1625	
3500	3265	5015	1750	3500	3445	5195	1750	
3750	3390	5265	1875	3750	3570	5445	1875	
4000	3515	5515	2000	4000	3695	5695	2000	
4500	3765	6015	2250	4500	3945	6195	2250	
5000	4015	6515	2500	5000	4195	6695	2500	
5500	4265	7015	2750	5500	4445	7195	2750	
6000	4515	7515	3000	6000	4695	7695	3000	
6500	4765	8015	3250	6500	4945	8195	3250	
7000	5015	8515	3500	7000	5195	8695	3500	

TRIPLEX FREE LIFT (3-stage /	ECG90-140				ECG100-180			
	Lift height	Mast height		Free lift	Lift height	Mast height		Free lift
	H4	H3 min	H5 max	H2	H4	H3 min	H5 max	H2
	4500	2970	5950	1500	4500	3130	6190	1500
5000	3137	6450	1667	5000	3297	6690	1667	
5500	3303	6950	1833	5500	3463	7190	1833	
6000	3470	7450	2000	6000	3630	7690	2000	
6500	3637	7950	2167	6500	3797	8190	2167	
7000	3803	8450	2333	7000	3963	8690	2333	

DUPLEX HEAVY-DUTY (2-stage)	ECG90-140				ECG100-180			
	Lift height	Mast height		Free lift	Lift height	Mast height		Free lift
	H4	H3 min	H5 max	H2	H4	H3 min	H5 max	H2
	4000	4065	5885	-	4000	4065	5885	-
4500	4315	6385	-	4500	4315	6385	-	
5000	4565	6885	-	5000	4565	6885	-	
5500	4815	7385	-	5500	4815	7385	-	
6000	5065	7885	-	6000	5065	7885	-	

Notes*:
 1. ECG90-140: models ECG90-6, 100-6, 120-6, 127-6 and 140-6.
 2. ECG100-180: models ECG150-6, 160-6, 180-6, 160-9, 100-12, 120-12, 150-12 and 160-12.
 3. ECG90/100/120-6 has 11.00x20" tires, when using 12.00x20" tires, please add +25 mm on H3 and H5. ECG127/140-6 has 12.00x20" tires, please add +25 mm on H3 and H5.
 4. Duplex Heavy-Duty: mast range with additional reinforcements.
 5. The lifting cylinders are mounted behind the mast profiles on Duplex Standard, Duplex Freelift & Triplex freelift. The lifting cylinders are mounted outside the mast profiles on Duplex Heavy-Duty. The freelift cylinders are mounted inside the mast profiles on Duplex Freelift and Triplex freelift.

Information correct at time of publication and is subject to change.

Attachments

Masts



Duplex standard
Lift height
3000 - 10000 mm

Heavy Duty
Lift Height
4000 - 6000 mm

Triplex full free lift
Lift height
4500 - 7000 mm

Carriages



Carriage with
Pin Type Apron

Fixed Carriage with
manually movable forks

Carriage Heavy Duty
[SS/FP]

Carriage
Centre Levelling

Carriage Sideshift

Forks

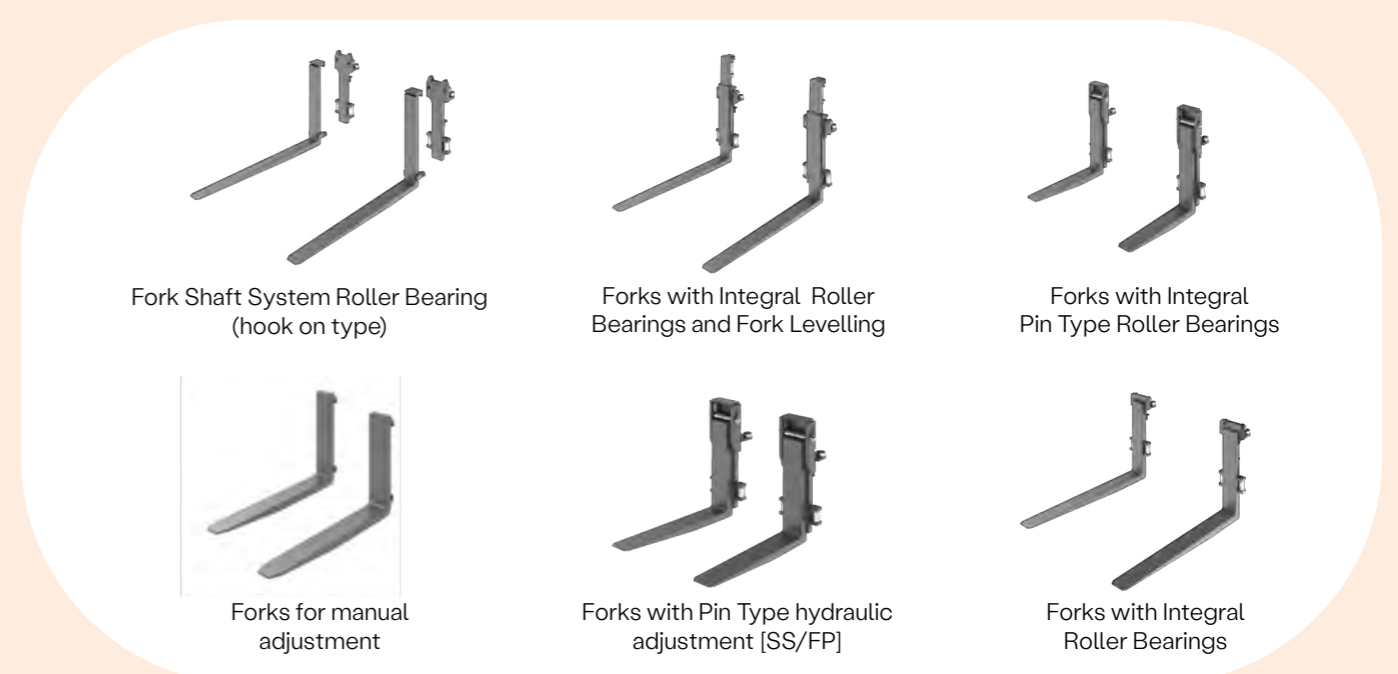

Fork Shaft System Roller Bearing
(hook on type)

Forks with Integral Roller
Bearings and Fork Levelling

Forks with Integral
Pin Type Roller Bearings

Forks for manual
adjustment

Forks with Pin Type hydraulic
adjustment [SS/FP]

Forks with Integral
Roller Bearings



Kalmar



BAMAG Maschinen AG

Moosackerstrasse 73, CH-8105 Regensdorf

Telefon 044 843 40 00

info@bamag-maschinen.ch

www.bamag-maschinen.ch

www.kalmarglobal.com

Published by Kalmar. Copyright © Kalmar Corporation 2025.
All rights reserved.

