

NEW

EC-Spider + Plus

ANNEXAIR 

**Quiet by design,
powered by
efficiency.**

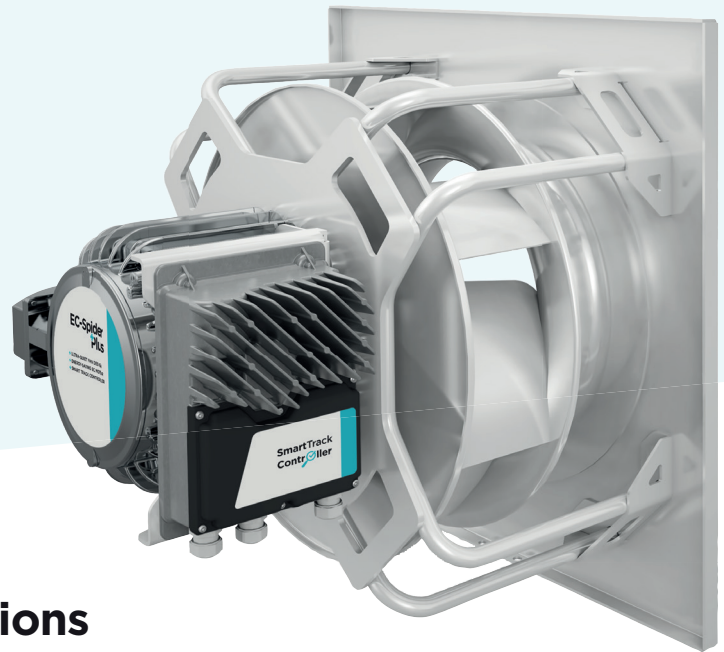

Redefining industry expectations

Annexair proudly introduces the *EC-Spider Plus*, the next evolution of our fan technology, now featuring an integrated fan-speed controller. The *EC-Spider Plus* series delivers everything that made the original *EC-Spider* exceptional and more.

Each fan array combines the industry's most efficient components, grouped together with everything you need, and nothing more.

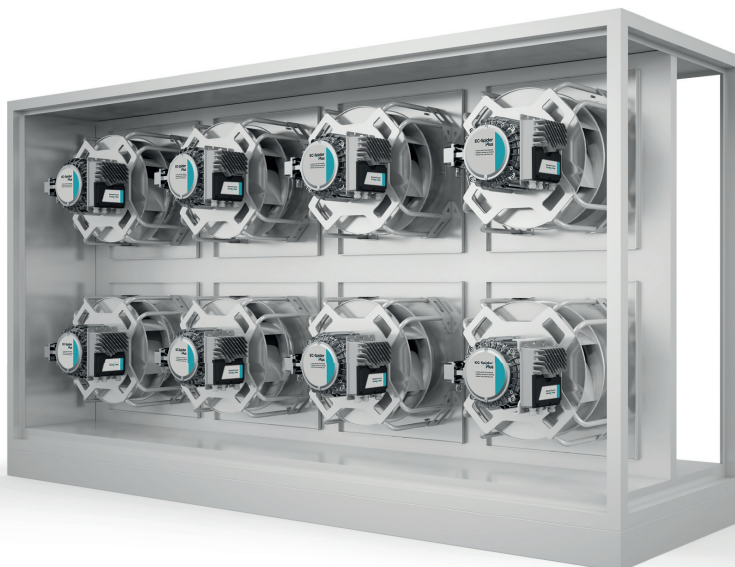

The *SmartTrack Controller* redefines performance and safety in HVAC fan control. Engineered with advanced electronics and built-in protection, it ensures unmatched reliability, even in demanding environments.

Mind-blowing performance

While HVAC fans may appear similar to the untrained eye, a closer look reveals the difference. Here's why the Annexair *EC-Spider Plus* is setting a new industry standard.

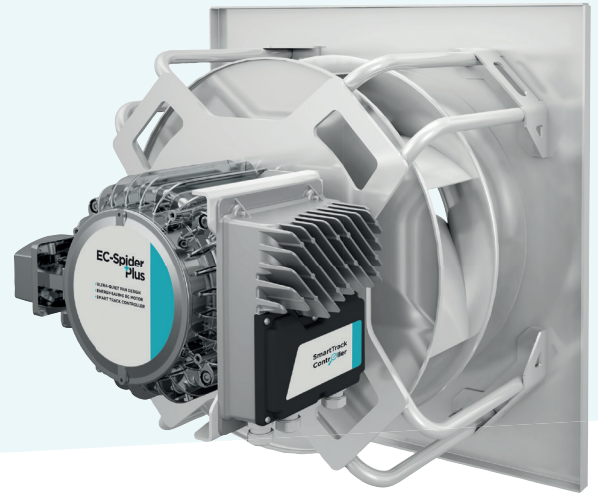

Motor

- Brushless EC/PM highly reliable technology
- Above IE5 (IE5+) ultra-premium efficiency class (See chart on page 6)
- IP54 protection against dust and humidity
- Aluminum housing construction with optional 10,000 hours salt spray coating
- Lifetime maintenance-free motor bearing — no lubrication required
- Isolated motor shaft to eliminate voltage-induced bearing wear



Fan assembly

- 100% epoxy-coated and zinc-plated for maximum corrosion resistance
- Non-obstructive air inlet for optimal airflow
- Box-free construction — fewer parts, less vibration
- Piezometer tap ready for optional airflow measurement
- Rigid, heavy-duty design built to last

Folded edge plate for improved rigidity and strength

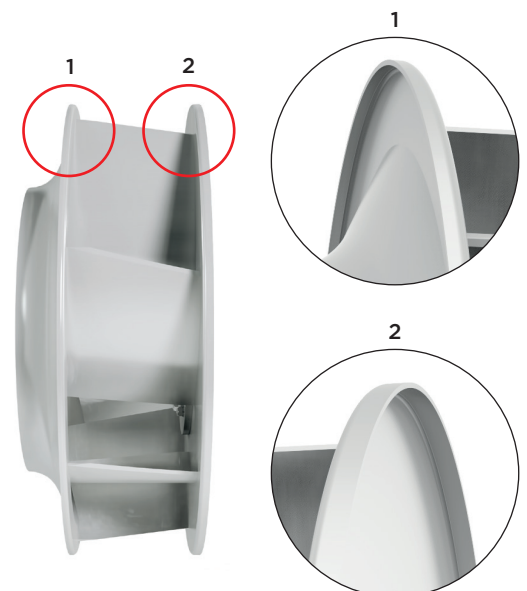

Fan wheel

- Rigid welded assembly withstands up to 10" TSP (all sizes)
- High quality aluminum construction with standard epoxy coating
- The airfoil blade design offers outstanding acoustics and extra-low dB
- Robotically welded diffuser wheel for precision balance
- Motor positioned outside the wheel for higher efficiency
- Meets AMCA #204-05 for balance and vibration (BV-3 standard, BV-5 optional)
- Folded edge plates for enhanced rigidity and strength

SmartTrack Controller: Peace-of-mind, always on track

The *SmartTrack Controller* powers the new *EC-Spider Plus*, delivering smart, durable, and easy-to-use control that outperforms traditional VFDs for steady, safe, and efficient operation.

Main features and benefits

- Factory-set controller customized for each project
- Designed exclusively for plug-fan applications
- Water-resistant IP65 / NEMA 4X enclosure
- Supports 0-10 V, Modbus RTU, or BACnet™ MS/TP
- Active vibration protection
- Self-cooling aluminum housing — no internal fans required
- 10,000 hours salt spray resistance
- Motor and controller can be replaced independently
- Motor capacity ranging from 2 kW to 13 kW
- Ultracompact footprint that simplifies projects
- Quick and easy access for maintenance and serviceability



Small but mighty

This new generation of controller is 40% smaller and 20% lighter than well-known VFD brands. Each component is carefully selected to optimize EC/PM motor performance, resulting in a compact, powerful, and elegantly engineered system.

Ignition-protected

All *SmartTrack Controllers* are certified ignition-protected to UL, CSA, and IEC standards — ensuring absolute safety and future-ready compliance.

Controlling

The *SmartTrack Controller* is factory-set using a dual cable for a 0-10V signal and through Modbus RTU.

Grid immunity

The *SmartTrack Controller* offers over-voltage detection, allowing the controller to survive in most types of grids worldwide. They are robust and handle grid disturbances such as notches, spikes and transients.

Built-in EMC filter

The *SmartTrack Controller* comes with a fully integrated EMC filter that meets the emissions and immunity norms for industrial and residential areas.

Heavy-duty construction casing

These fan controllers are CE and cRUUs approved, and are capable of continuous operation with an all-condition performance, including UV resistant and NEMA 4X.

A step ahead of conventional VFDs

Most VFDs include components and wiring designed for generic applications, not plug fans. The Annexair *SmartTrack Controller* does exactly what's required and nothing more. Fewer parts. Lower costs. Higher reliability.

Water-resistant casing IP-65 NEMA 4X

Water-resistant design prevents corrosion, moisture damage, and energy loss — extending system life and reducing maintenance costs. **EC-Spider Plus** controller is fully sealed, IP65 / NEMA 4X certified, making it an unmatched fan controller in the HVAC industry.



Active fan vibration monitoring

Each **EC-Spider Plus** fan is equipped with an active, built-in vibration sensor that continuously monitors the rotating assembly. If vibration levels rise beyond safe limits, the **SmartTrack Controller** automatically slows the fan wheel to prevent potential damage.

The controller then attempts up to five automatic resets, returning the fan to normal speed once stability is restored. If vibration persists, it maintains a safe reduced speed and activates an alarm on the HMI, alerting operators to the condition.

This intelligent safeguard provides real-time protection, extending component life and preventing downtime, and an alarm notification will be activated on the HMI.

FAN VIBRATION FEEDBACK EXAMPLE



FAN RPM RESPONSE

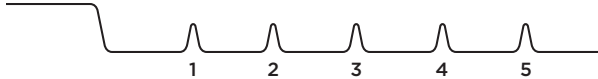

Active fan vibration monitoring ensures that the fans are operating within safe parameters, thereby preventing any damage to the fans.

Self-cooling innovation

Since this product is designed to be mounted directly on the plug fan, the engineering team has created an oversized heat sink casing combined with special internal chips, resulting in a unique fan controller that does not require fans. Self-cooling guaranteed.

Three balancing procedures prior to unit shipment

EC-Spider Plus fans are renowned for their exceptional balance, a quality that sets them apart from other manufacturers in the industry:

1. The wheel itself is balanced at the manufacturer's plant
2. The fan assembly is completed and balanced at the Annexair factory (see photo below)
3. The fans are balanced when they are installed at their final location during unit quality-control testing

These three quality-control processes ensure that **EC-Spider Plus** fans always meet balance and vibration category BV-3 (optional BV-5).



Annexair's fan department is equipped with the latest state-of-the-art, high-precision measuring and balancing machines to optimize fan performance.

Overheating faults — solved.

Traditional VFDs demand ventilated enclosures to handle heat. The **EC-Spider Plus** eliminates this need with its self-cooling design, preventing overheating, reducing service calls, and allowing smaller, more efficient units.



Standard HMI for fan monitoring

As a new feature, all Annexair units equipped with *EC-Spider Plus* fans include an integrated HMI for control and monitoring. This interface allows users to view all settings and alarms. It is factory-programmed and installed inside the unit.

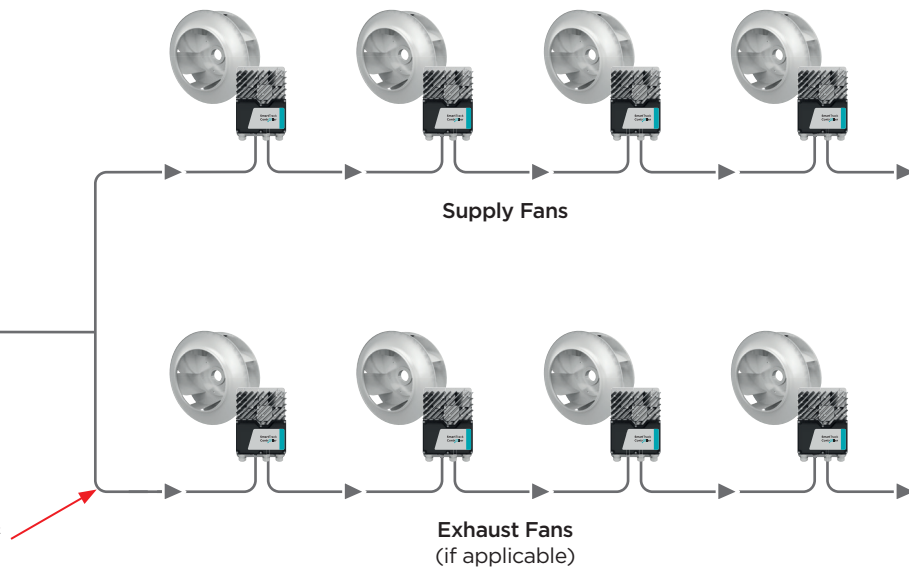

Combined wired cables for 0-10V signals & Modbus RTU or BACnet™ MSTP monitoring

Options

- **Coating protection for extreme conditions**

In addition to our standard corrosion resistant aluminum motor casings, Annexair also offers an optional 10,000 hours salt spray coating for the most demanding applications.

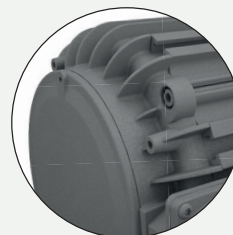
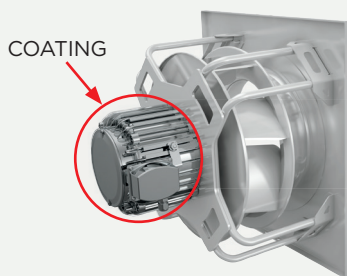

Coated
(Optional)

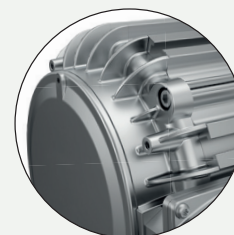

Uncoated
(Standard)

- **Ultra low harmonic**

Our standard *EC-Spider Plus* fans will be compliant to IEC 61000-3-12:2011 but for the most demanding projects, optional 3% or 5% line reactors can be offered.

- **BV-5 balancing**

As an option, *EC-Spider Plus* fans can be balanced to meet the most stringent BV-5 (2mm/s) vibration level per AMCA 204.

Efficiency class comparison chart

Annexair's *EC-Spider Plus* fan motors exceed the ultra-premium IE5 efficiency class, surpassing IE3, IE4, and IE5 by up to 10%, 6%, and 3% respectively.

EC-Spider Plus motor vs AC motor

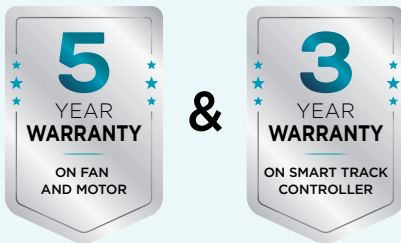
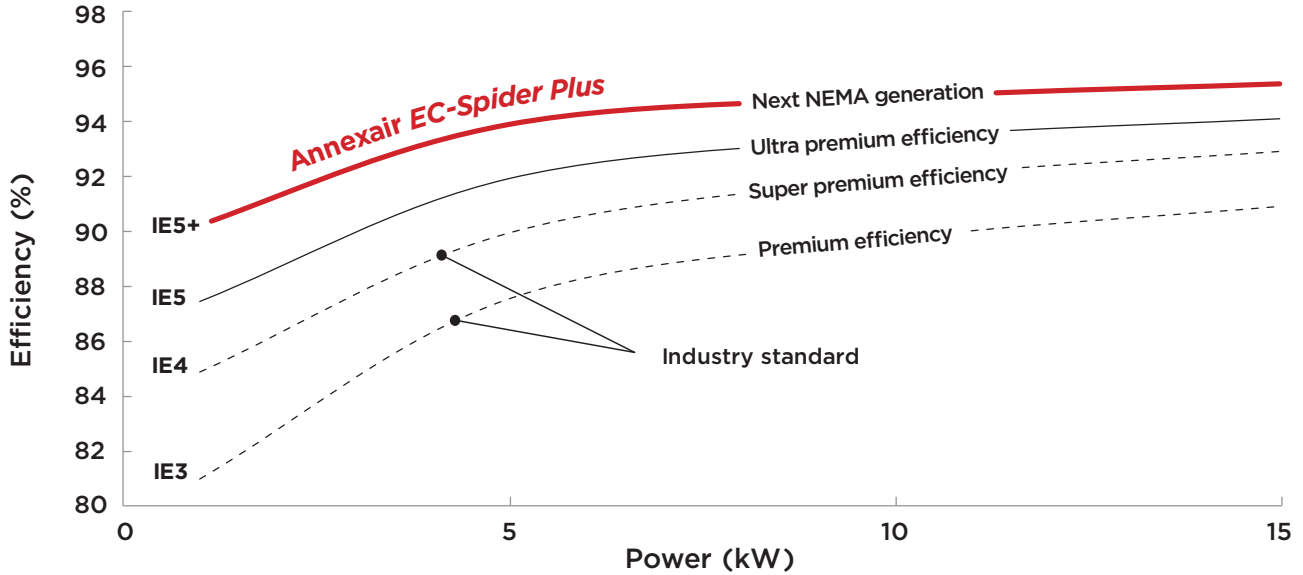

Warranty coverage: 5-Year & 3-Year protection

We are so confident in the quality and reliability of our products, which is why we offer the following warranty coverage:

EC Motor and Fan Assembly: Covered for a period of five (5) years

SmartTrack Controller: Covered for a period of three (3) years

For full warranty details, please visit annexair.com



253 de l'Energie Street
St-Germain-de-Grantham (Quebec)
J0C 1K0 Canada

www.annexair.com



Type of certification depends on variant.