

**POWERLIFT® ELECTRIC SERIES**

# PowerLift® Hopper Fill Vacuums

Industrial vacuums designed to be more reliable for you.

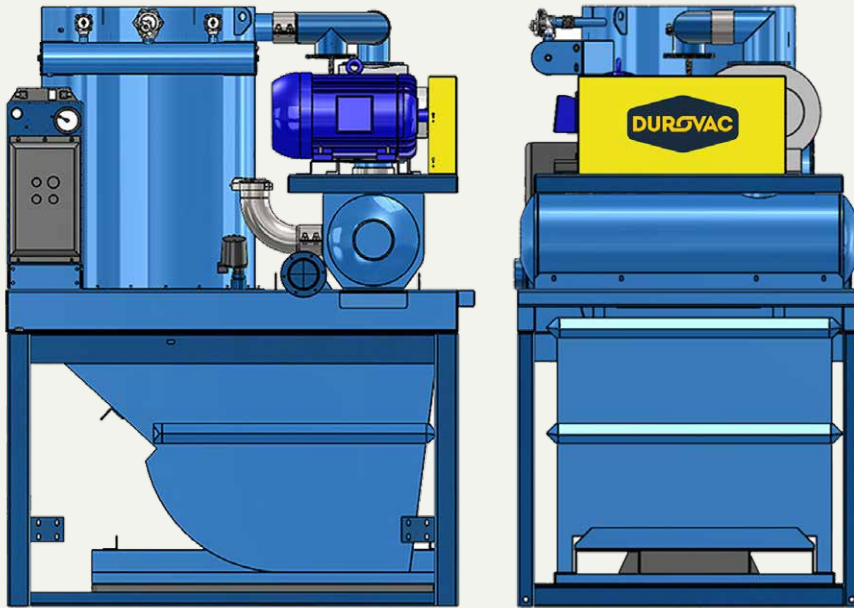

- Filters so good they last years, not months. Low, low cost of ownership.
- Trouble-free operation with super-fine powders and heavy abrasive granules.
- Storage is collected in an easy-to-handle, extreme duty waste hopper.



The reliable PowerLift® vacuum provides the high-vacuum you need to clean up production areas fast.

PowerLift® by DuroVac moves material fast and keeps your plant or mill clean and safe. This all-in-one package features maximum suction and huge onboard storage. It's perfect for any dry debris that will convey in a hose.

With thousands of configurations, your PowerLift® will have the right horsepower and filtration options for the job. You'll have a 100% customized, high performance vacuum cleaning solution you can depend on.

Let us help you select a durable industrial vacuum that just keeps on working.



The PowerLift® industrial vac solves your large cleaning problems. Here is a 75 Hp with a 2.5 yd<sup>3</sup> hopper.

**WITH ITS TOUGH, TESTED DESIGN**, the PowerLift® lets you vacuum heavy abrasives reliably without internal wear. And the system's onboard storage of up to 2.5 cubic yards means you can tackle production spills and transport them easily by lift truck.

- Exclusive abrasion-proof inlet with hose connections on both sides.
- Self-cleaning filters that last 10x longer than industry standard.
- Easy upgrade to 99.97% HEPA filter.
- Standard NFPA Compliant options.

## Specifications

Model Number	PL20	PL25	PL30	PL40	PL50	PL75
<b>System Horsepower</b>	20 Hp	25 Hp	30 Hp	40 Hp	50 Hp	75 Hp
<b>Number of Hoses</b>	1 x 2.5" 2 x 2.0"	2 x 2.0"	2 x 2.0" (3 x 2.0") <sup>2</sup>	3 x 2.0"	1 x 5.0"	1 x 6.0"
<b>Performance (TPH)<sup>1</sup></b>	3.5	4.0	4.5	6.0	8.0	12.0
<b>Air Flow - Inlet (CFM)</b>	400	525	650	860	1050	1550
<b>Vacuum (Maximum)</b>	16" Hg.	16" Hg.	16" Hg.	16" Hg.	16" Hg.	15" Hg.
<b>Standard Filter Area (ft<sup>2</sup>)</b>	85.5	85.5	85.5	121.0	121.0	207.0
<b>Pulse Filter Area (ft<sup>2</sup>)</b>	120.0	120.0	120.0	210.0	210.0	300.0
<b>Hopper Volume (Yrd<sup>3</sup>)</b>	1.33	1.33	1.33	2.0	2.0	2.5
<b>Noise Level @ 3ft (dBa)</b>	85	85	85	85	85	85
<b>Weight (lbs)</b>	3350	3450	3500	4820	4900	7250

1. Performance is rated for foundry sand with a 50 ft long hose. Lighter material moves faster, heavier material slower. Moves 1 lb/min less for every 1 ft longer hose.  
2. Configuration for light materials only.



**Reliable, simple operation with a tough vacuum that just keeps on working.**

Designed from the ground up to ensure the lowest possible maintenance, PowerLift® has faster ROI than any other hopper in its class.

Contact us today. We'll take good care of you.

[sales@durovac.com](mailto:sales@durovac.com)