

ALUMERO

EN

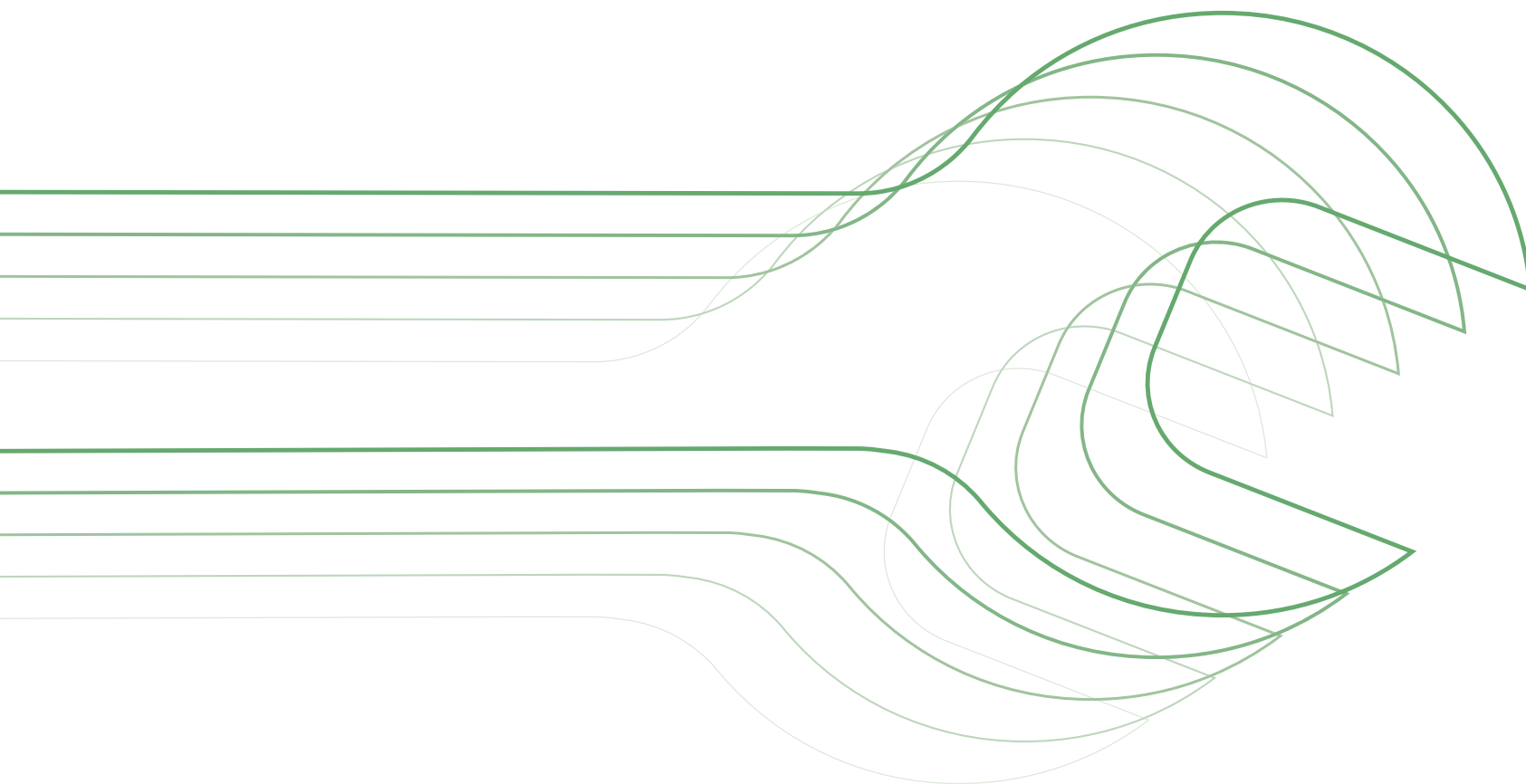

**SUSTAINABLE
SOLAR
SOLUTIONS**

easySPEED 2
ASSEMBLY INSTRUCTIONS

FOREWORD

easySPEED 2 is an aerodynamic mounting system for framed PV modules, designed for the installation of photovoltaic systems on flat roofs.

The modules are installed with a tilt angle of approximately 10° in an East/West orientation. The position is secured through ballast weighting, with no roof penetration required.

Prior to installation, make sure you have the most recent version of the installation instructions and read them thoroughly. This manual explains the assembly steps for the easySPEED 2 mounting system, its components, the modules, and the ballast weighting.

The planning and ballast calculations for the easySPEED 2 mounting system must be done using the Solar.Pro.Tool software. The layout of the ballast blocks, the required components, and their positions can be found in the project report generated by your ALUMERO sales partner. **This information is critical for the safe and proper operation of the PV system!**

ALUMERO assumes no liability for failure to adhere to the installation instructions or the project-specific structural engineering prepared with the Solar.Pro.Tool, nor for any incorrect information provided by the customer for the creation of the project report. The current ALUMERO General Terms and Conditions and warranty terms apply.

Before starting installation, the PV system installer must ensure that the roof structure can bear the additional loads. Consult a local structural engineer if necessary. Before construction, verify the compressive strength of the roof insulation and roof membrane, as well as the coefficient of friction. The area and point loads of the easySPEED 2 system can be found in the project-specific project report.

A PV system is not maintenance-free. An annual inspection and an inspection immediately after any storm event are recommended. In particular, the positioning of the ballast blocks must be checked. easySPEED 2 is exclusively designed for the installation of framed PV modules in a horizontal orientation. All other uses are considered unintended.

The modules are generally, but not exclusively, clamped on the short side. Clamping on the long side is also possible, as well as a combination of both in the heavy-duty variant for particularly demanding conditions. Before starting construction, the installer must confirm whether short side clamping is permitted for the specific module. This approval can be found in the module's certification or, if necessary, a project-specific release can be requested from the module manufacturer. The installation may only be performed by trained and qualified personnel.

If you have further questions, take advantage of ALUMERO's professional and comprehensive consulting service.

CONTENT

General	General Information	4
	Component Overview	5
	System Overview	6 – 8
Assembly	Important Information Before Build Up	9
	1 Raisers	10
	2 Rails	11 – 12
	3 Module Fields	13 – 15
	4 Fixing Raisers	16
	5 Module Clamping	17 – 21
	6 Ballasting	22 - 26
	Lightning Protection	27 – 28
References	29	

GENERAL INFORMATION

Technical Data

Use	Membrane, bitumen (with and without thermal insulation), concrete and gravel roofs	
Inclination	0° - 5°	
Modules	Type:	Framed modules
	Dimensions:	Width: 900 – 1500 mm Length: 1500 – 2500 mm
	Orientation:	Horizontal
	Field size:	Max. 20 x 25 meters Min. 4 double modules (2 double modules overhang)
	Inclination:	~10° (typically 9 - 12°, depending on module width)
Distances	Roof:	~ 300 mm
	Roof edge:	Min. 600 mm
Loads	Wind:	Up to 3,00 kN/m ² (suction load)
	Snow:	Up to 5,76 kN/m ² *
Position / Verification of stability	Software assisted based on wind tunnels investigations and construction standards	
On-site requirements	The structural load-bearing capacity of the roof construction and the building structure, as well as the compressive strength of the roof build-up, must be ensured on-site. The general terms and conditions, warranty conditions, and usage agreement apply. Module approval must also be verified on-site.	
Screw mounting	M8 (A2-70)	
Torque	≤ 15 NM	
Material	Load bearing connecting parts: Aluminium EN AW 6063 T66 and EN AW 6005A T6; Module clamps: Aluminium EN AW 6063 T66; Screws: stainless steel A2-70, ballast trays: steel with aluminium-zinc-coating; Fleece: non-woven polyester	

* depending on system variant and used PV modules

Installation on gravel roofs

The existing gravel should be removed so that the easySPEED 2 base plates have direct contact with the roof surface. The removed gravel can be reused as ballast when combined with gravel trays. It is also possible to install the system directly on the gravel. In any case, it must be verified that a suitable protective fleece, in accordance with applicable regulations, has been used beneath the gravel. However, we recommend consulting ALUMERO for project-specific clarification.

Please note:

Refer to the respective module installation manual for information on the maximum load capacity of the PV modules and the approved clamping areas.

Required Tools



Cordless screw driver mit socket bit SW6



Torque wrench

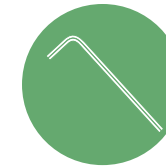

Hexagon wrench SW6

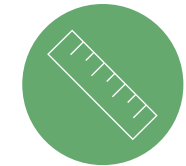

ALUMERO assembly jig

COMPONENT OVERVIEW



Base Plate
140 x 480 mm
Product No.: 200123



Base Plate
240 x 480 mm
Product No.: 200124



Raiser small
Product No.: 200121



Double raiser small
Product No.: 200134



Raiser large
Product No.: 200135



Profile holder
Product No.: 200129



Shim below ballast tray
Product No.:
200123-220



Ballast tray 2025
Product No.:
200106-2025



Gravel ballast tray 2025
Product No.:
200107-2025



Middle clamp 30-40
Product No.:
200302-30-40



End clamp 30
Product No.: 200305-30



H-rail 1100
for module width
990 - 1200 mm
Product No.:
200127-1100



Cross profile 1980
for module length
up to 1800 mm
Product No.:
200128-1980



Assembly jig
Product No.: 110303

Ballast tray 2225
Product No.: :
200106-2225

Gravel ballast tray 2225
Product No.:
200107-2225

**Middle clamp 30-40
black**
Product No.:
200392-30-40

End clamp 30 black
Product No.: 200395-30

End clamp 35
Product No.: 200305-35

End clamp 35 black
Product No.: 200395-35

H-rail 1300
for module width
1200 - 1400 mm
Product No.:
200127-1300

Cross profile 2600
for modul length
up to 2441 mm
Product No.:
200128-2600



Hexagon socket bolt
Product No.: 800617

Ballast tray 2475
Product No.: :
200106-2475

Gravel ballast tray 2475
Product No.:
200107-2475

Cross profile 3700
for 2 modul lengths
up to 1762 mm
Product No.:
200128-3700

Cross profile 6300
for custom solutions
Product No.:
200128-6300



Cable tie incl. Clip
Product No.: 800706



Washer
Product No.: 823002-24



Ballast brace
Product No.: 200133



Ballast clip
Product No.: 200130

SYSTEM OVERVIEW

SHORT SIDE CLAMPING

Row spacing:
long - long - long



Row spacing:
long - long - short



Row spacing:
long - short - short

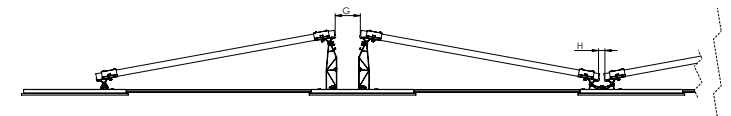
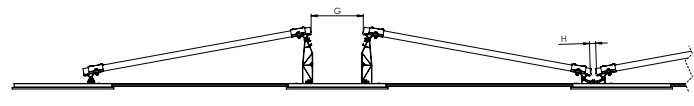
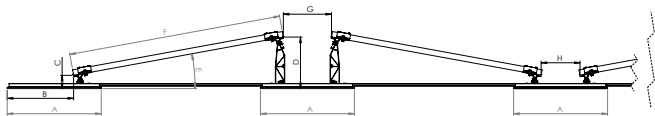

Row spacing	A (mm)	B* (mm)	C* (mm)	D* (mm)	E**	F (mm)	G (mm)	H* (mm)
long - long - long	500	~ 353,2	~ 70,6	~ 274,2	7,7° - 12°	990 - 1500	~ 256,2	~ 206,6
long - long - short	500	~ 353,2	~ 70,6	~ 274,2	7,7° - 12°	990 - 1500	~ 256,2	~ 30
long - short - short	500	~ 353,2	~ 70,6	~ 274,2	7,7° - 12°	990 - 1500	~ 117,7	~ 30

* Depending on mounting angle

** Depending on module width

SYSTEM OVERVIEW

LONG SIDE CLAMPING

Row spacing:
long - long - long

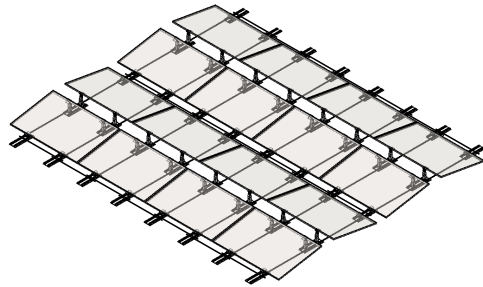

Row spacing:
long - long - short

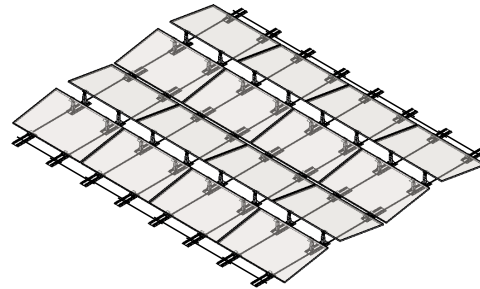

Row spacing:
long - short - short

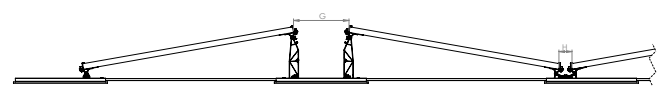
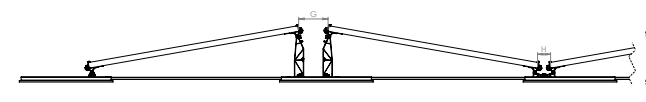
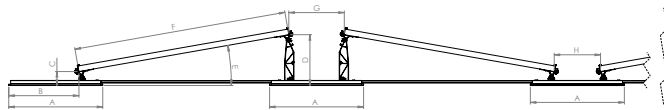
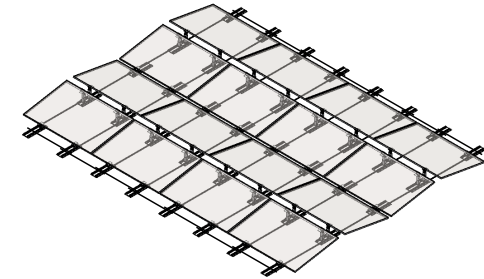

Row spacing	A (mm)	B * (mm)	C * (mm)	D * (mm)	E ** (mm)	F (mm)	G (mm)	H * (mm)
long - long - long	500	~ 373,2	~ 74,3	~ 270,6	7,5° - 11,5°	990 - 1500	~ 295,2	~ 206,6
long - long - short	500	~ 373,2	~ 74,3	~ 270,6	7,5° - 11,5°	990 - 1500	~ 295,2	~ 69,6
long - short - short	500	~ 373,2	~ 74,3	~ 270,6	7,5° - 11,5°	990 - 1500	~ 156,7	~ 69,6

* Depending on mounting angle

** Depending on module width

SYSTEM OVERVIEW

HEAVY DUTY VARIANT

Row spacing:
long - long - long



Row spacing:
long - long - short



Row spacing:
long - short - short

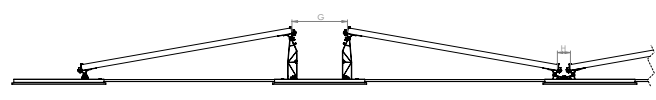
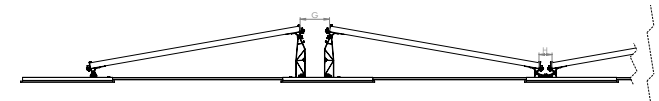
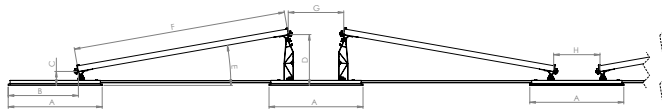

Row spacing	A (mm)	B* (mm)	C* (mm)	D* (mm)	E**	F (mm)	G (mm)	H* (mm)
long - long - long	500	~ 373,2	~ 74,3	~ 270,6	7,5° - 11,5°	990 - 1500	~ 295,2	~ 206,6
long - long - short	500	~ 373,2	~ 74,3	~ 270,6	7,5° - 11,5°	990 - 1500	~ 295,2	~ 69,6
long - short - short	500	~ 373,2	~ 74,3	~ 270,6	7,5° - 11,5°	990 - 1500	~ 156,7	~ 69,6

* Depending on mounting angle

** Depending on module width

IMPORTANT INFORMATION BEFORE BUILD UP

VALID FOR ALL INSTALLATION VARIANTS

- All project-specific information regarding the setup of the system can be found in the **Solar.Pro.Tool Project Report**, including:
 - Module field dimensions
 - Number and position of rails
 - Number and position of ballast trays, gravel trays, and cross profiles
 - Ballasting options and quantities
- Installation can be performed either directly with the modules or in advance using the ALUMERO assembly jig.
- For precise alignment of the system on the roof, the use of a chalk line is recommended.

ASSEMBLY

1 | RAISERS

Beginning & end raiser / raiser small
-> Always mount at the end of the base plate!

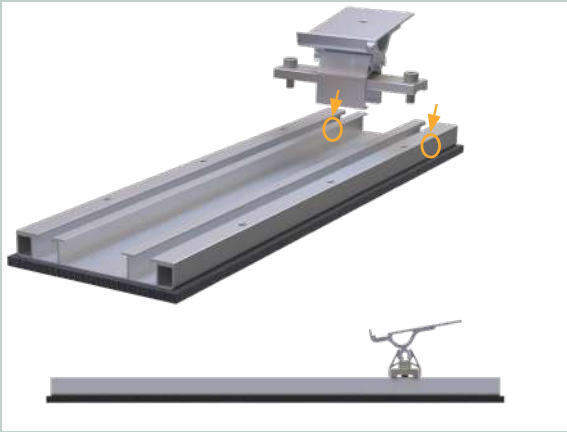

Double raiser small - short spacing
-> Always mount at the end of the base plate!

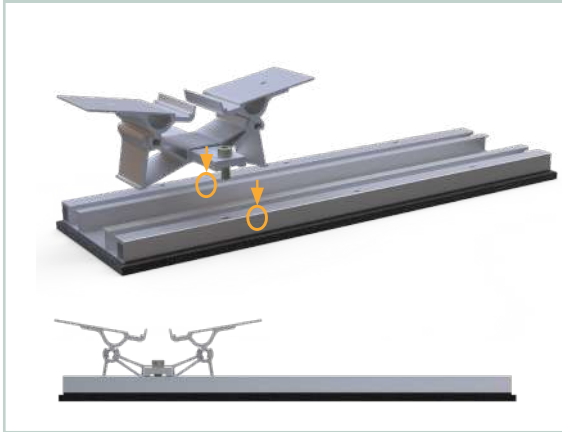

Raiser small - long spacing

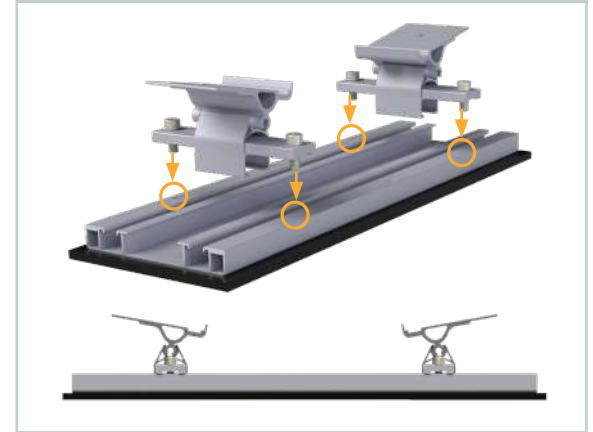

Raiser large - short spacing



Raiser large - long spacing



ASSEMBLY

2 | RAILS

If your installation does not use H-rails, you can skip this page.

Important: H-rails are mandatory if the system must be able to carry lightning current.

- **Aligning the first row**

Align the first row of modules straight using a chalk line. The example image shows installation from left to right.

- **Positioning the H-rail**

The H-rail must be placed in the **channel opposite the module**.

If H-rails overlap, the **second channel of the base plate** can be used.

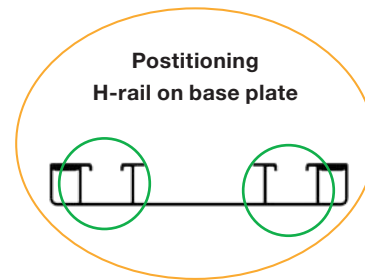

- **Installation within the module field**

Always install the H-rail in the direction of installation — that is, the direction in which you mount the modules one after the other.

- **Tip for quick and precise installation**

Install complete rows (rails) in advance to enable precise alignment later.

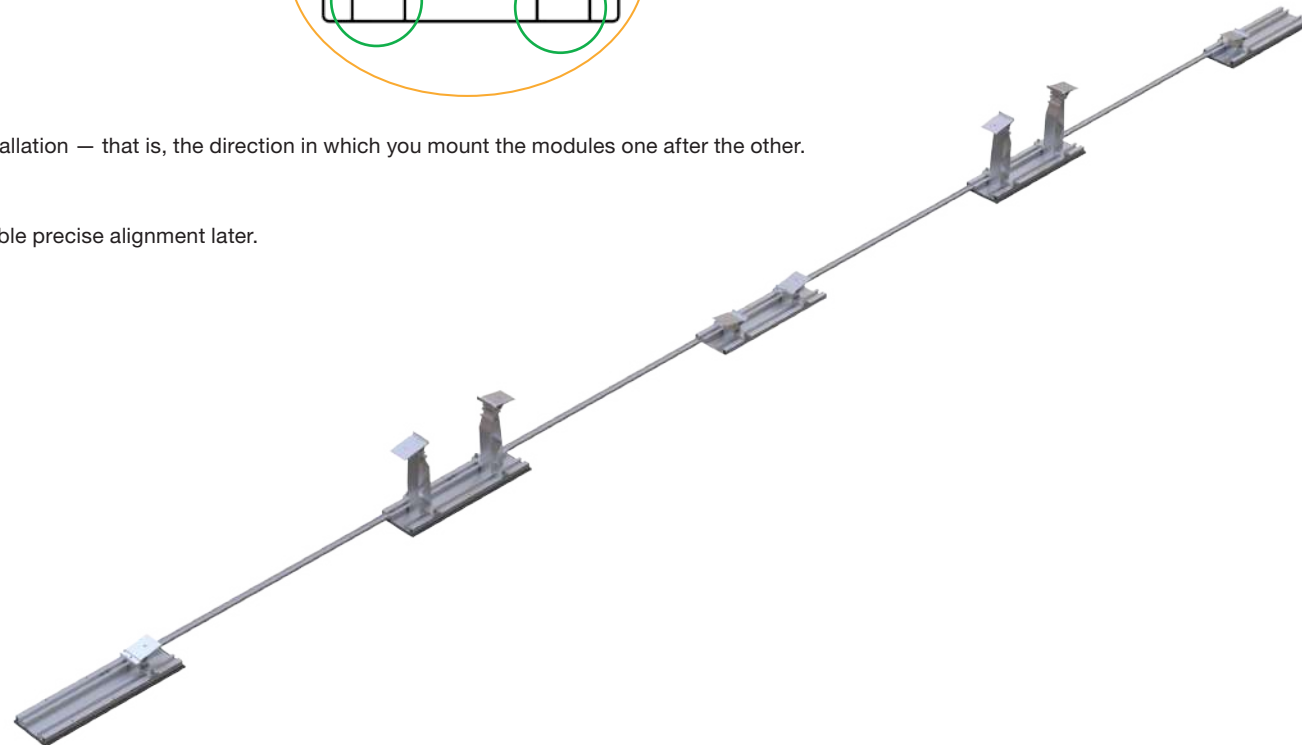

ASSEMBLY

2 | RAILS

Installation with the ALUMERO assembly jig without modules

- Adjusting the clamping outer dimensions on the jig:
 - **Clamping on the short side of the module:** The measured value equals the module width (e.g. 1134 mm).
 - **Clamping on the long side of the module or Heavy Duty version:** Module width + 40 mm (e.g. 1134 mm + 40 mm = 1174 mm)
- **Important for „long side clamping“ and „Heavy Duty“** (with additional supports in the middle of the module):
 - Do not exceed the marking edge on the installation adapter.
 - It is recommended to **pre-install the end clamps** (see pages 18/19) to adhere precisely to the marking.



- **Adjusting the jig & fixing H-rails**

Position the assembly jig on the base plate and fix the spacing with the H-rail (see example image).

Important: H-rails must be installed before the module installation. The H-rails must be placed in the **channel opposite the module**.

- **Building additional Rows**

Repeat the steps described until the entire module field is installed according to the Solar.Pro.Tool Project Report.

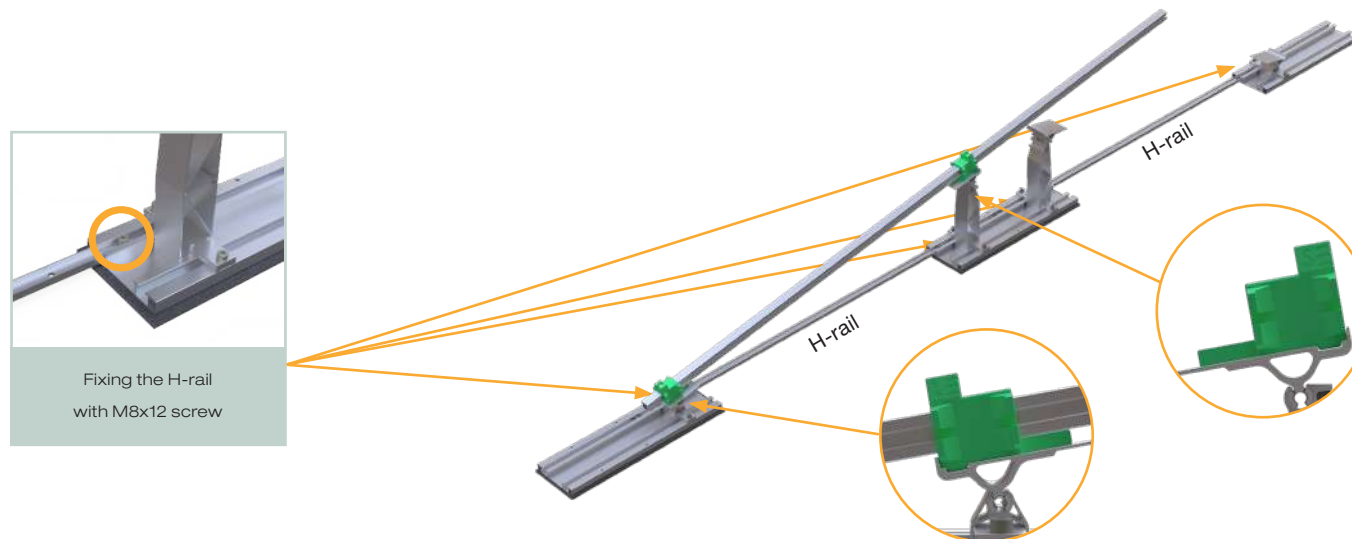

ASSEMBLY

3A | MODULE FIELD SHORT SIDE CLAMPING

Setting the distance between base plates with the assembly jig:

Calculation for the outer edge of the jig: module length + 70 mm

Example: 1722 mm + 70 mm = 1792 mm (outer edge of the assembly jig)

Before releasing the connections of the installation jigs, fix the distances of the base plates (see „Fixation system raisers“ on page 16).

To optimize installation time, it is recommended to use at least 4 assembly jigs.

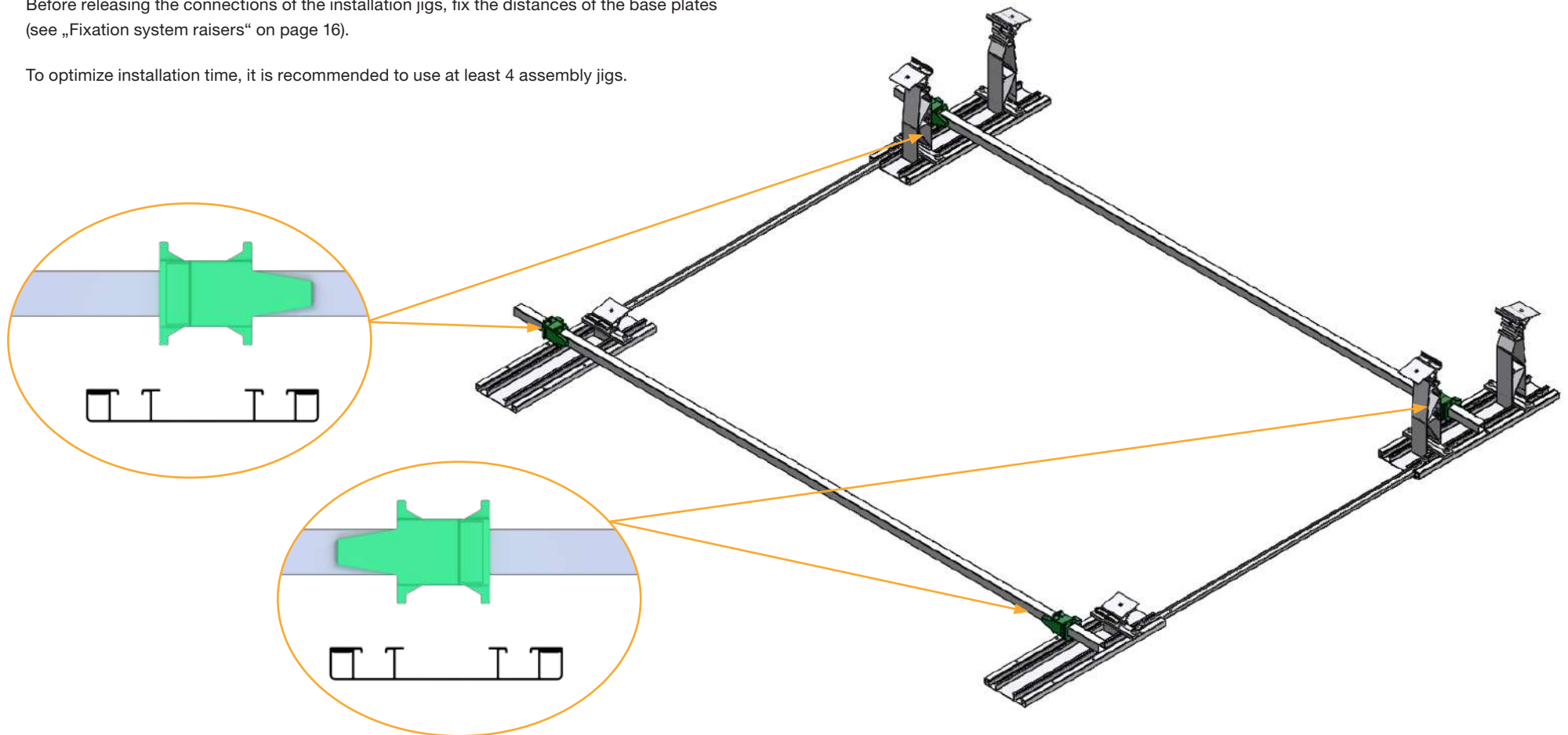

ASSEMBLY

3B | MODULE FIELD LONG SIDE CLAMPING

Setting the distance between base plates with the assembly jig:

Calculation for the outer edge of the jig:

$$\frac{(\text{Module length} + 20 \text{ mm})}{2} + 50 \text{ mm}$$

$$\text{e.g.: } \frac{(1722 \text{ mm} + 20 \text{ mm})}{2} + 50 \text{ mm} = 921 \text{ mm}$$

Before releasing the connections of the installation jigs, fix the distances of the base plates (see „Fixation system raisers“ on page 16).

To optimize installation time, it is recommended to use at least 4 assembly jigs.

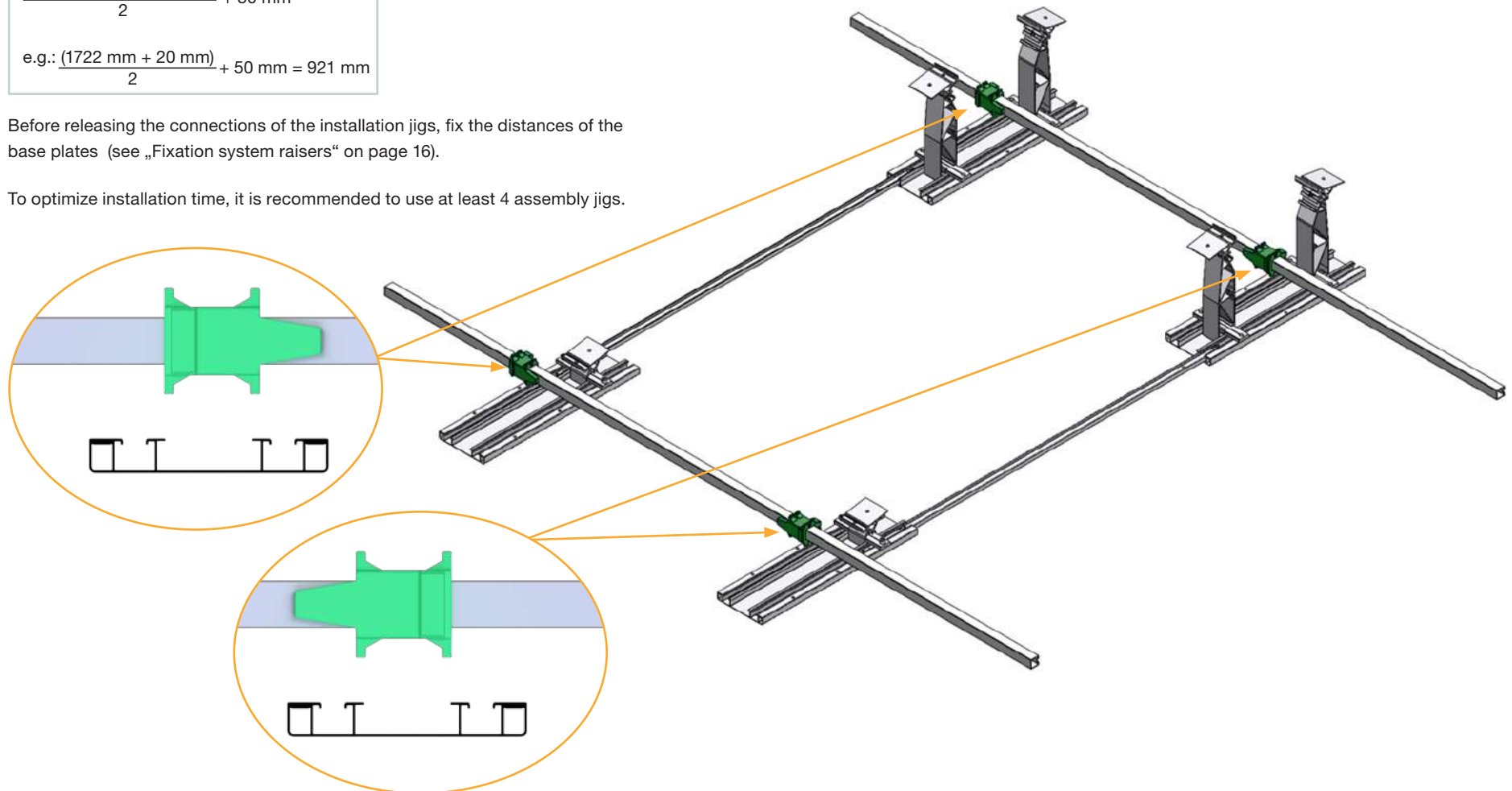

ASSEMBLY

3C | MODULE FIELD HEAVY DUTY CLAMPING

Setting the distance between base plates with the assembly jig:

Calculation for the outer edge of the jig:
$$\frac{(\text{Module length} + 20 \text{ mm})}{2} + 50 \text{ mm} = 921 \text{ mm}$$

e.g.: $\frac{(1722 \text{ mm} + 20 \text{ mm})}{2} + 50 \text{ mm} = 921 \text{ mm}$

Before releasing the connections of the installation jigs, fix the distances of the base plates (see „Fixation system raisers“ on page 16).

To optimize installation time, it is recommended to use at least 6 assembly jigs.

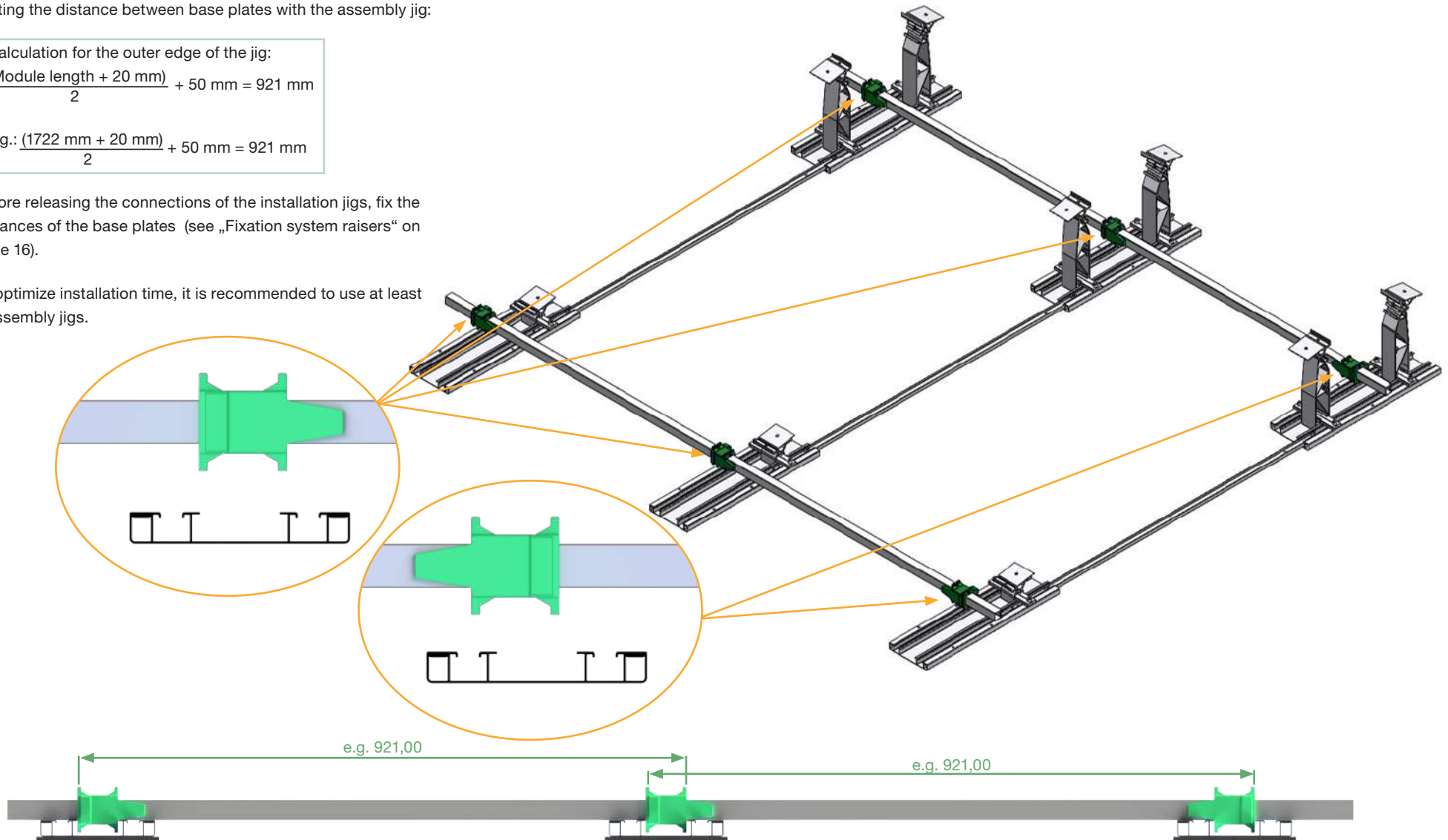

ASSEMBLY

4 | FIXATION SYSTEM RAISERS

The exact position and quantity required of cross profiles to fix the system raiseres can be found in the **Solar.Pro.Tool Project Report**.

1. Insert the **profile bracket with threaded plate** into one of the **narrow channels of the base plate**.
2. **Push the cross profile into the bracket and fix it.**

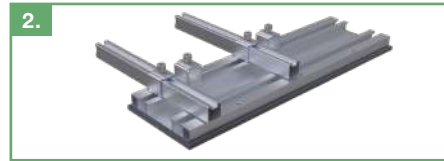

Attention: When using **ballast trays**, be sure to adhere to the specific requirements stated in the chapter “Ballast & Gravel Trays”.

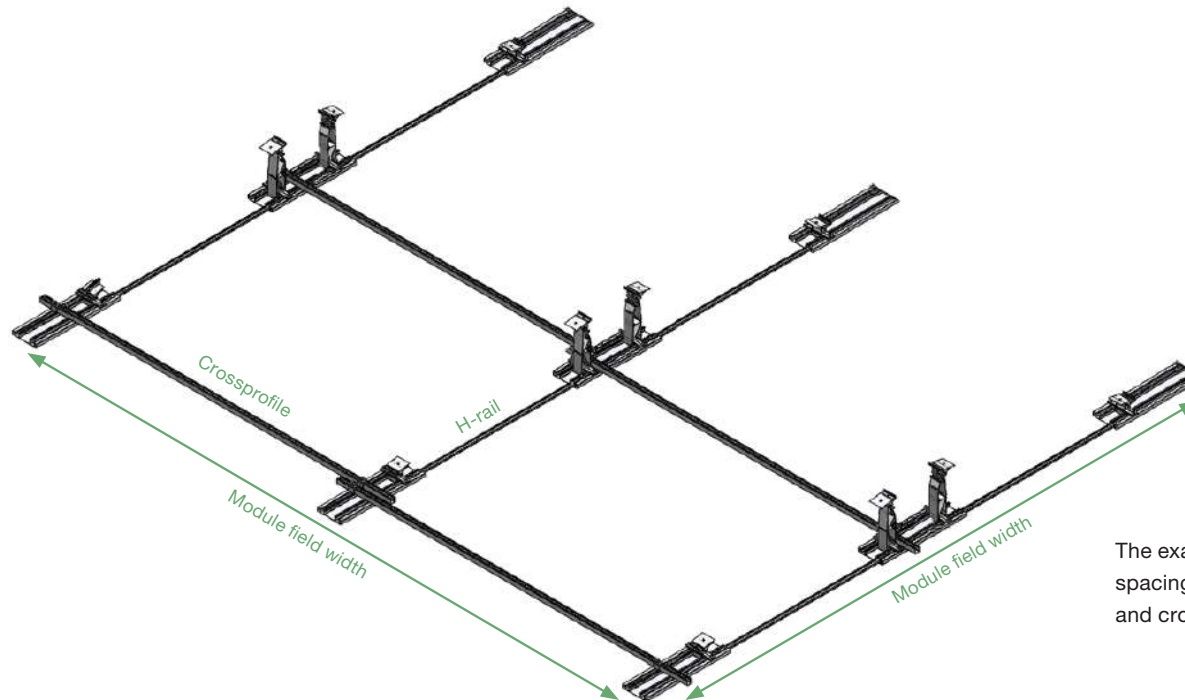

The example image may differ from the actual spacing of supports. The quantity of H-rails and cross profiles used may also vary.

ASSEMBLY

5 | MODULE CLAMPING

Notes on long side clamping:

- The connection of the module field must be fully reinforced with cross profiles.
- Ballast trays and gravel trays are NOT allowed when clamping the long side!
Normally, a single cross profile is enough to bridge a field length and serve as reinforcement.
- If ballast needs to be added directly on the cross profile, additional profile brackets can be attached to enable ballast placement.

Installation variants with and without H-rails when clamping the long side:

- With H-rails: Cross profiles must be mounted at the beginning and end of each module field as well as at the ridge.
- Without H-rails: Cross profiles are required at the beginning and end of each module field, as well as at the ridge and eaves.

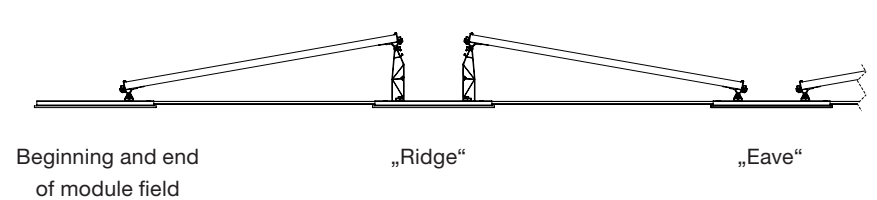

ASSEMBLY

5A | SHORT SIDE CLAMPING

Pre-assembly of clamps is possible but only recommended if the modules are already on site.

Overview image without cross profiles/ballast trays for better visibility.

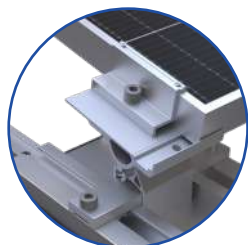
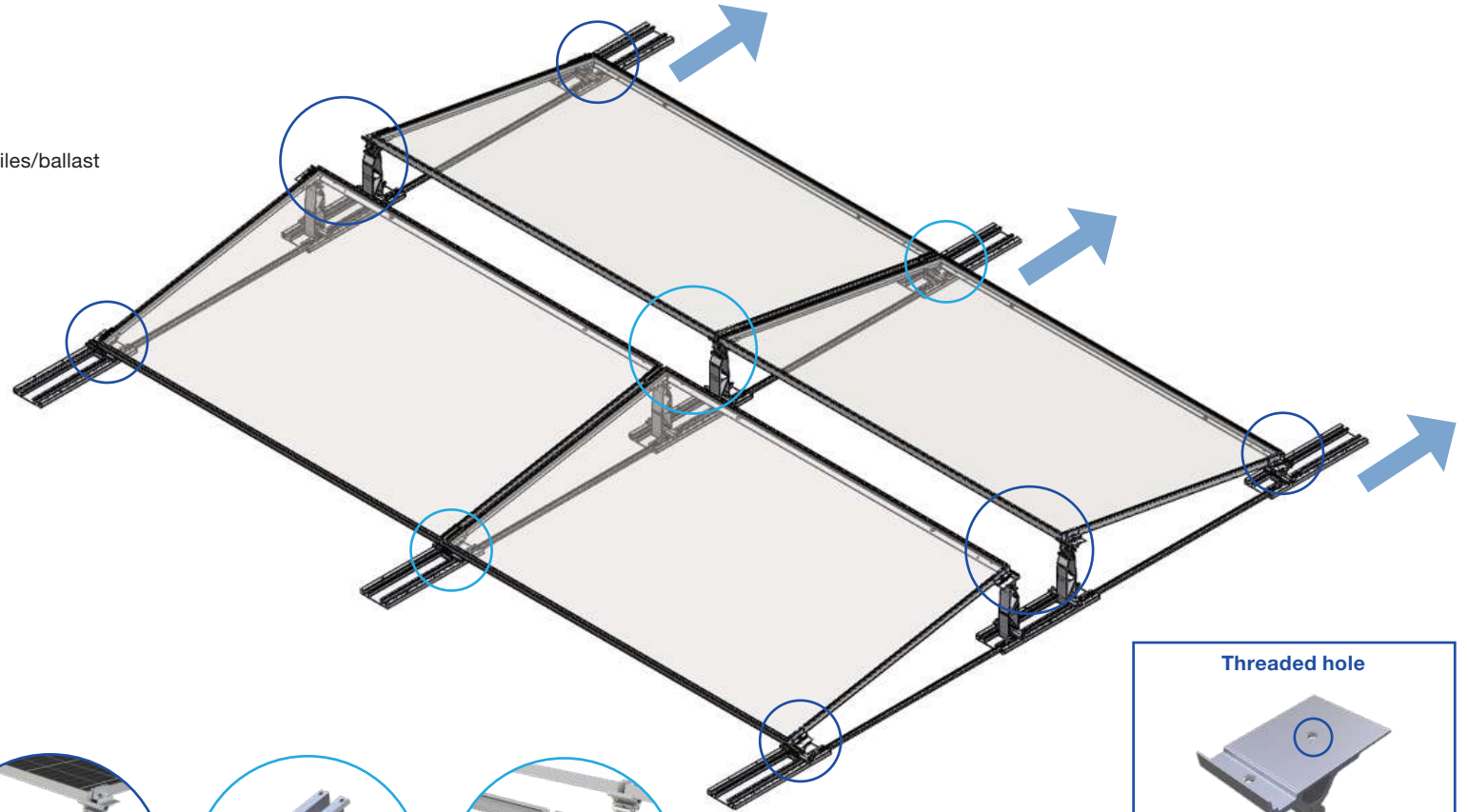

End clamp



End clamp

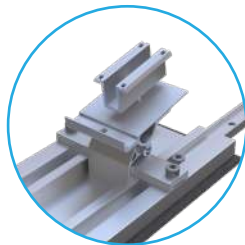

Middle clamp



Middle clamp

Threaded hole



Threaded hole for mounting clamps on the short side, both for end clamps and middle clamps. Also applies when extending the module rows.

MONTAGE

5B | LONG SIDE CLAMPING

Pre-assembly of clamps is possible but only recommended if the modules are already on site.

Overview image without cross profiles/ballast trays for better visibility.

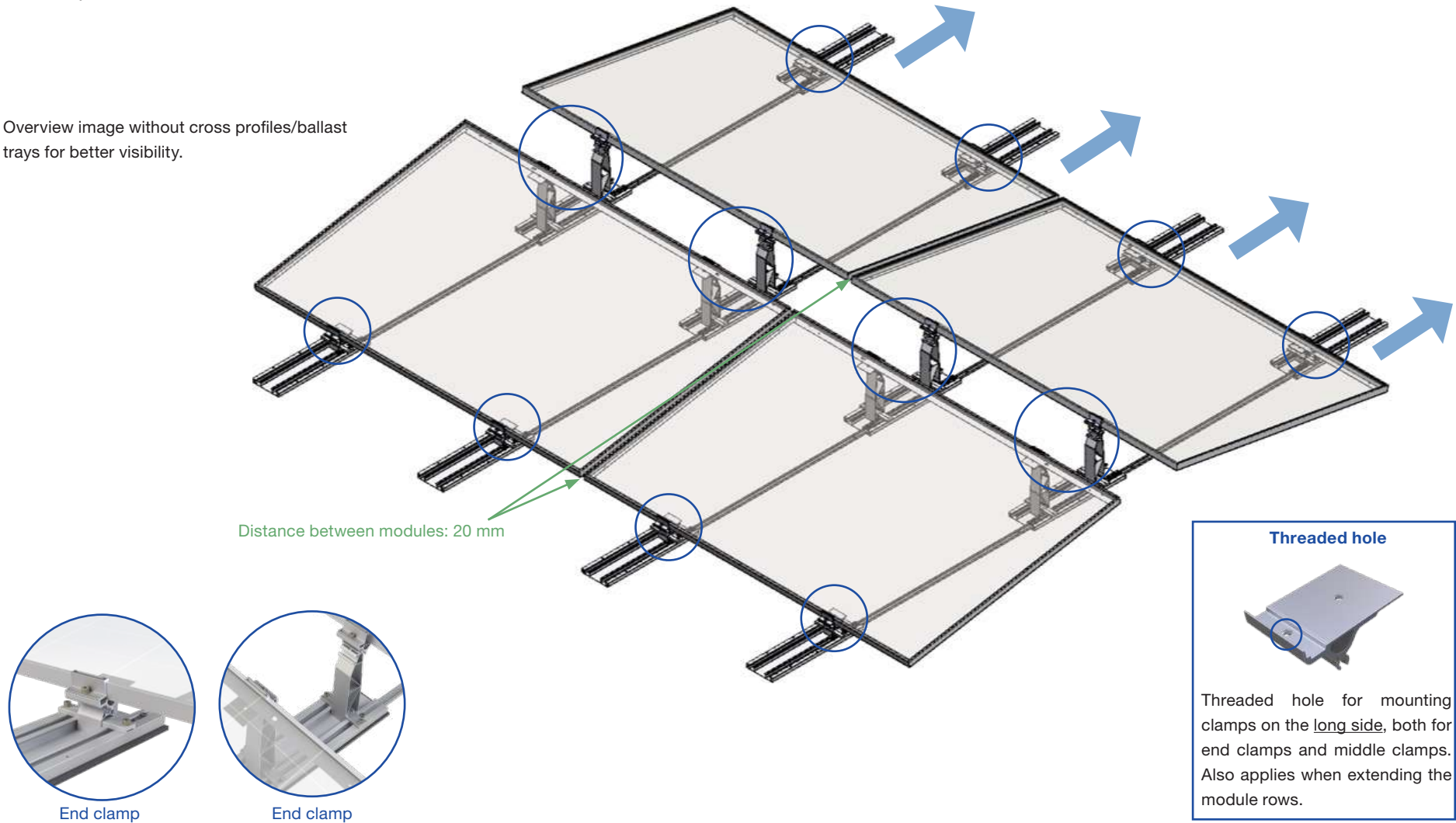

ASSEMBLY

5B | LONG SIDE CLAMPING

In general, a continuous connection with cross profiles must be established to ensure the structural integrity of the system. To achieve this, one cross profile is required from base plate to base plate each.

When attaching clamps to the long side of the module, only cross profiles may be used. This variant must not be combined with ballast or gravel trays. To enable additional ballasting, a second cross profile can be mounted to attach ballast clips.

If the “clamping on long side” variant is used without H-rails, a cross-connection must be established at the “eaves” and “ridge” areas.

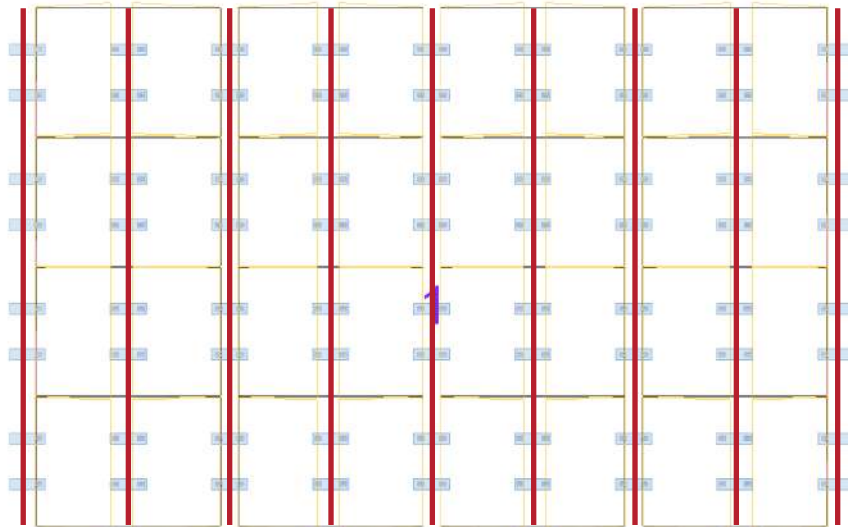

If the “clamping on long side” variant is used with H-rails, a cross-connection must be established at the beginning and end of the module array, as well as at the “ridge”.

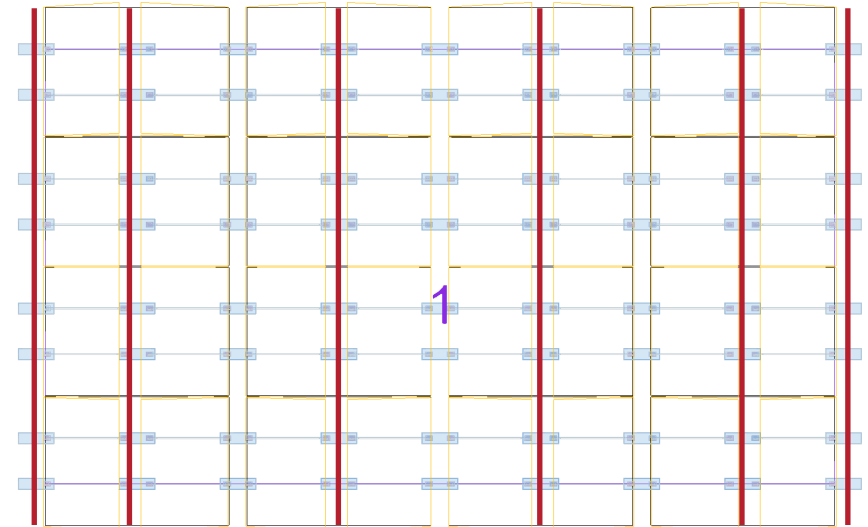

ASSEMBLY

5C | KLEMMUNG MODULE HEAVY DUTY

Pre-assembly of clamps is possible but only recommended if the modules are already on site.

Overview image without cross profiles/ballast trays for better visibility.

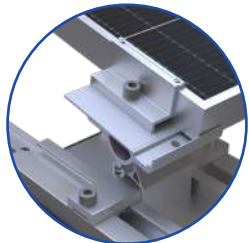
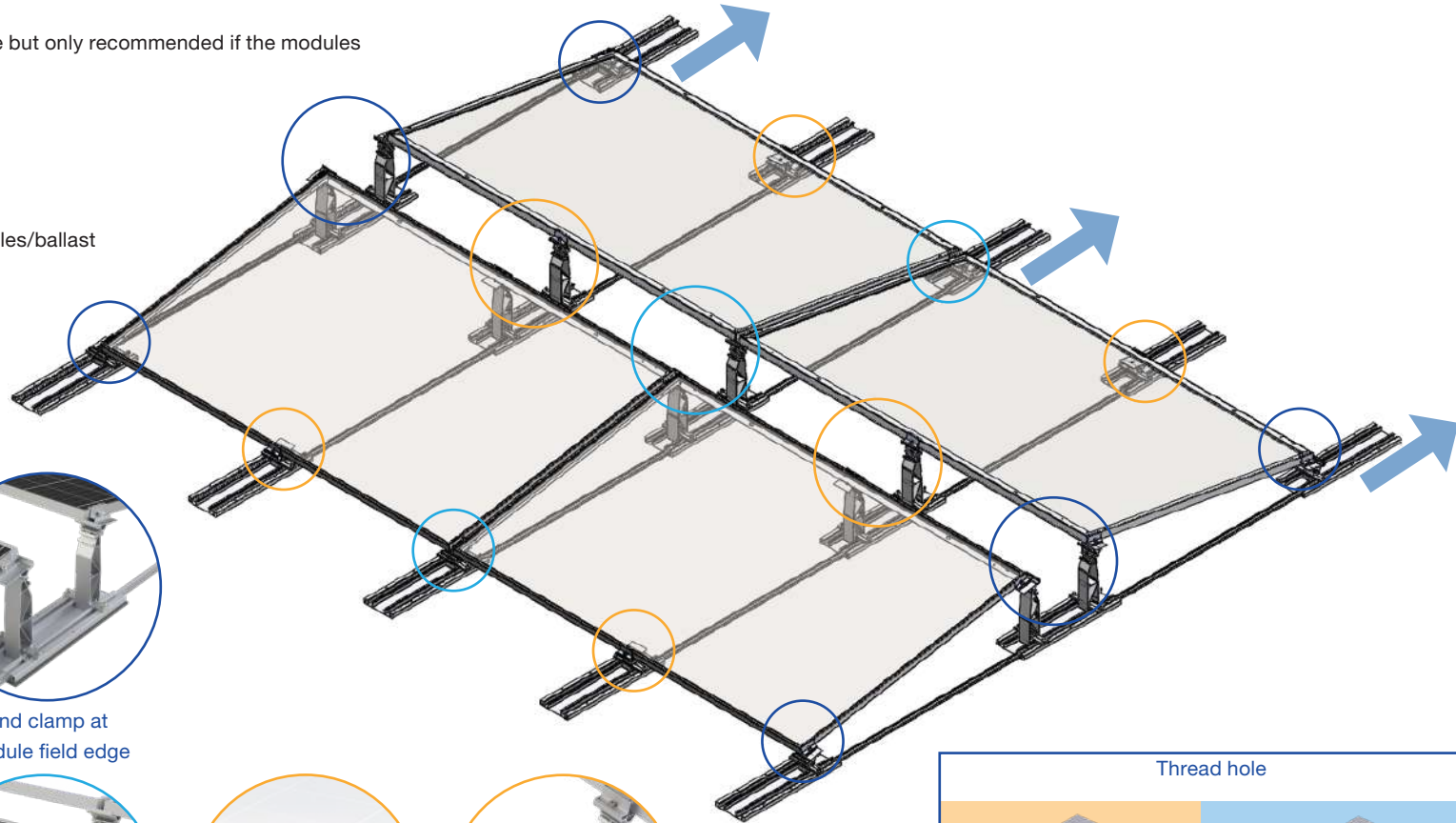

End clamp at module field edge



End clamp at module field edge

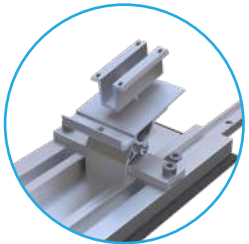

Middle clamp between two modules



Middle clamp between two modules

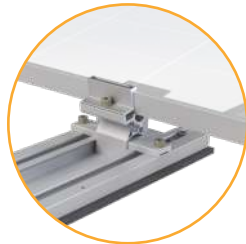

End clamp for reinforcing the middle of the module



End clamp for reinforcing the middle of the module

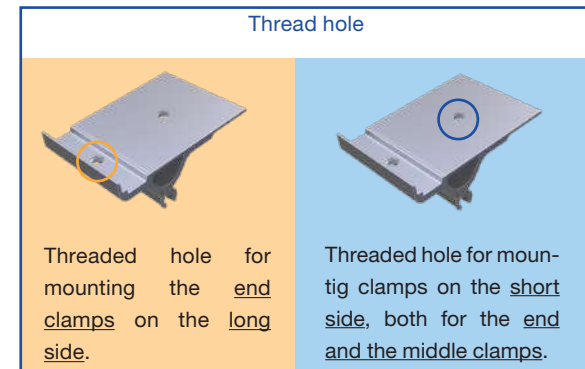

BALLASTING

- Ballast is calculated for each project individually via the **Solar.Pro.Tool**.
- The **number** of ballast stones that are required to hold the system in place, and at **which points**, is calculated based on the dimensions and weight of the ballast stones used.
- The easySPEED 2 system is designed for ballast stones up to a **maximum size of 500 × 222 × 105 mm**.
- **We recommend** using stones with dimensions of **300 × 200 × 60 mm**, as these are **ideal for volumetric ballast calculations**.

Installation Notes:

- The ballast elements may be positioned directly on the base plates. However, the use of **ballast clips, clamps, or ballast trays** is generally advised — and is strongly recommended for installations in seismically active regions. It is the responsibility of the PV system installer to determine and verify this requirement prior to installation.
- When working with short row spacing, ballast placement should be done **before placing and fixing the modules**.
- All ballast stones must be laid **lengthwise — parallel to the module orientation in landscape format**.
Exception: At the **beginning and end of the arrays**, as well as at the “**ridges**“, the ballast stones must be **rotated by 90°** and placed across the profiles so that they run **parallel to the H-rails**. The orientations are indicated by arrows in the Solar.Pro.Tool project report.

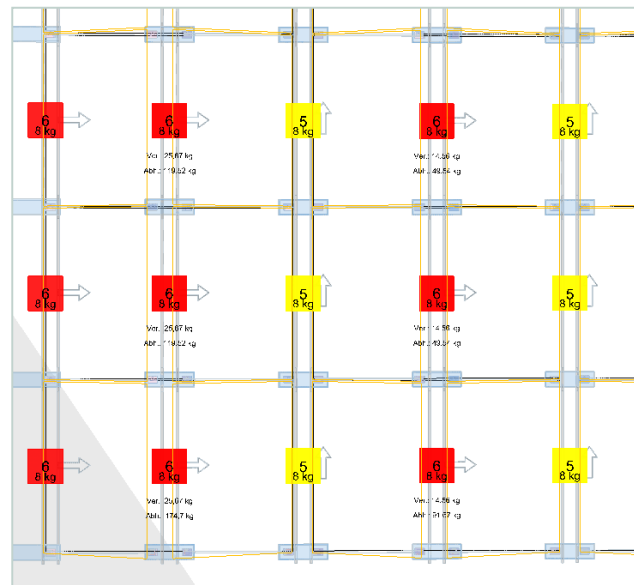

BALLASTING

6A | ASSEMBLY OF BALLAST CLIPS

- The ballast clips can be mounted by simply pressing them onto the connecting rail. By sliding the connecting rail, the distance of the ballast clips can be precisely adjusted to match the ballast stone used.

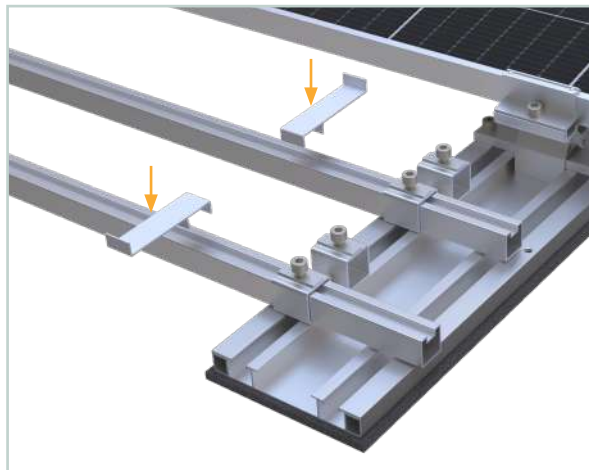

Example:
Use of ballast clips with short row spacing.

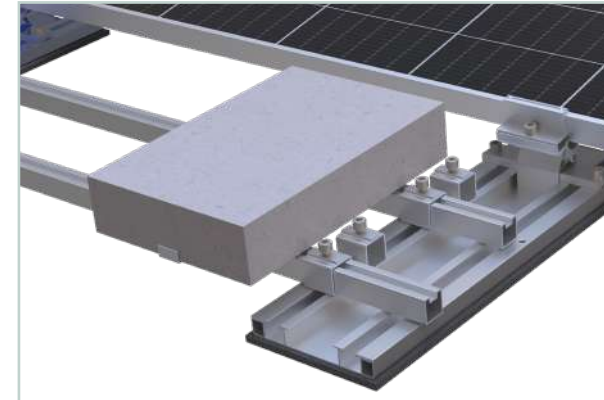

- **ATTENTION:** When clamping on the long side of the module, only cross profiles may be used. Ballast or gravel trays must NOT be used when clamping on the long side of the module.
- As a general rule: Depending on the project's requirements, multiple cross profiles per module array may be required for structural reasons. These profiles ensure both the necessary stability and the lightning current carrying capacity of the structure (further information in the „Lightning Protection“ chapter, page 27).
- For clamping along the long side of the module, a continuous cross-profile connection must be guaranteed to reliably dissipate static loads. When cross profiles are used in addition to ballast, two parallel cross profiles are required to securely position the ballast stones.
- **Note:** Not every module row needs cross profiles. The required positions and quantities can be found in the Solar.Pro.Tool project report.

BALLASTING

6B | ASSEMBLY BALLAST BRACKETS

The ballast bracket is mounted by pressing it into the base plate.

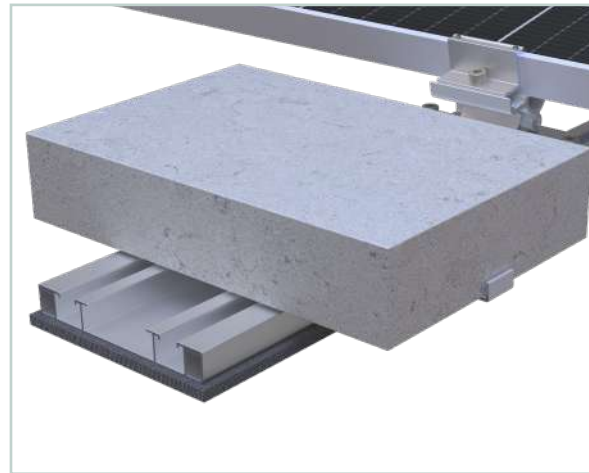
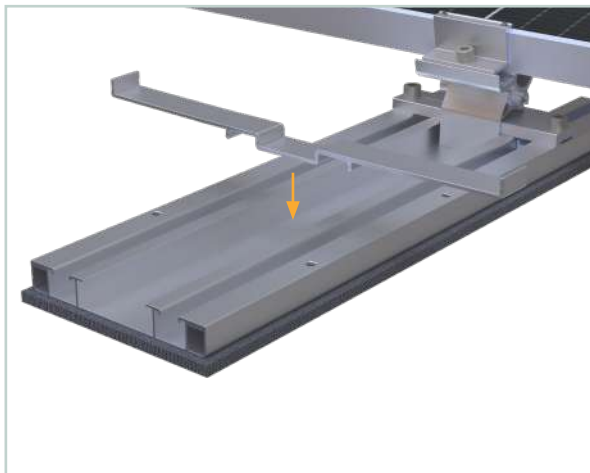
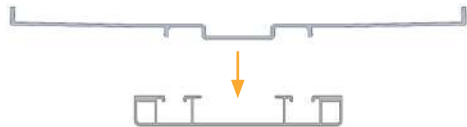

Example:
Use of ballast clamps for short row spacing.



BALLASTING

6C | ASSEMBLY BALLAST TRAYS

- When using ballast trays, underlay plates are mandatory.
- If ballast trays are placed under the modules, they must be ballasted before the module installation.
- The ballast tray is positioned on the base plate and screwed to it using the existing slotted holes.
- Each base plate and underlay plate must be secured with one screw and one washer.

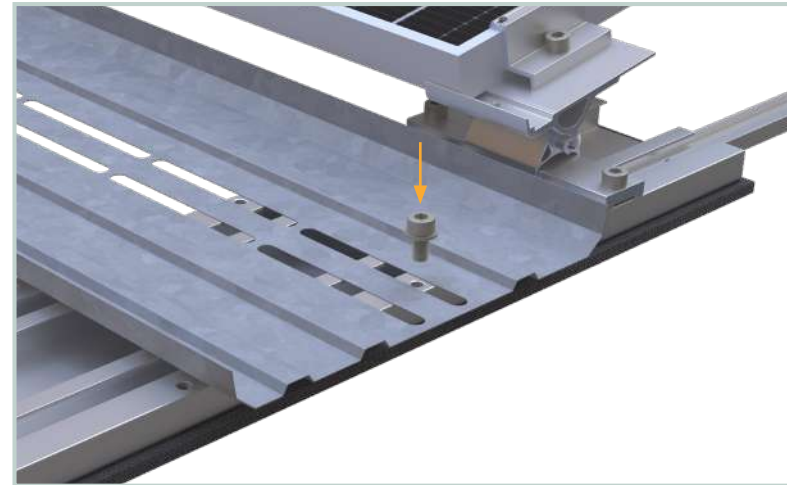

Number of underlay plates per ballast tray:

For low ballast (fewer than 8 stones or <64 kg) one underlay plate per ballast tray is sufficient.

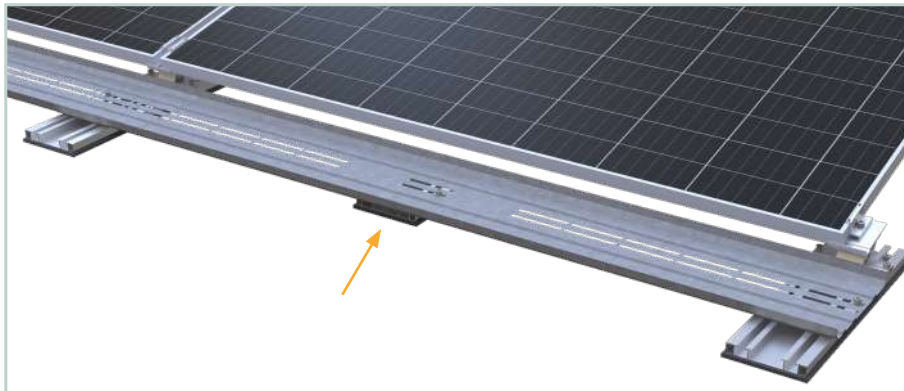

For higher ballast (more than 8 stones or >64 kg) **two** underlay plates per ballast tray are required.

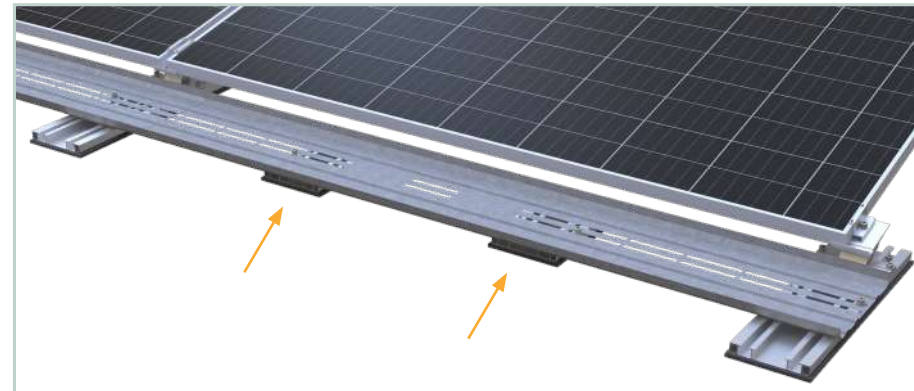

BALLASTING

6D | ASSEMBLY BALLAST TRAYS HEAVY DUTY

For the Heavy Duty variant, underlay plates are required from 8 stones or >64 kg. These are positioned centrally between the base plates. The position is indicated in the Solar.Pro.Tool project report.

If ballast trays are placed under the modules, they must be ballasted before the module installation.

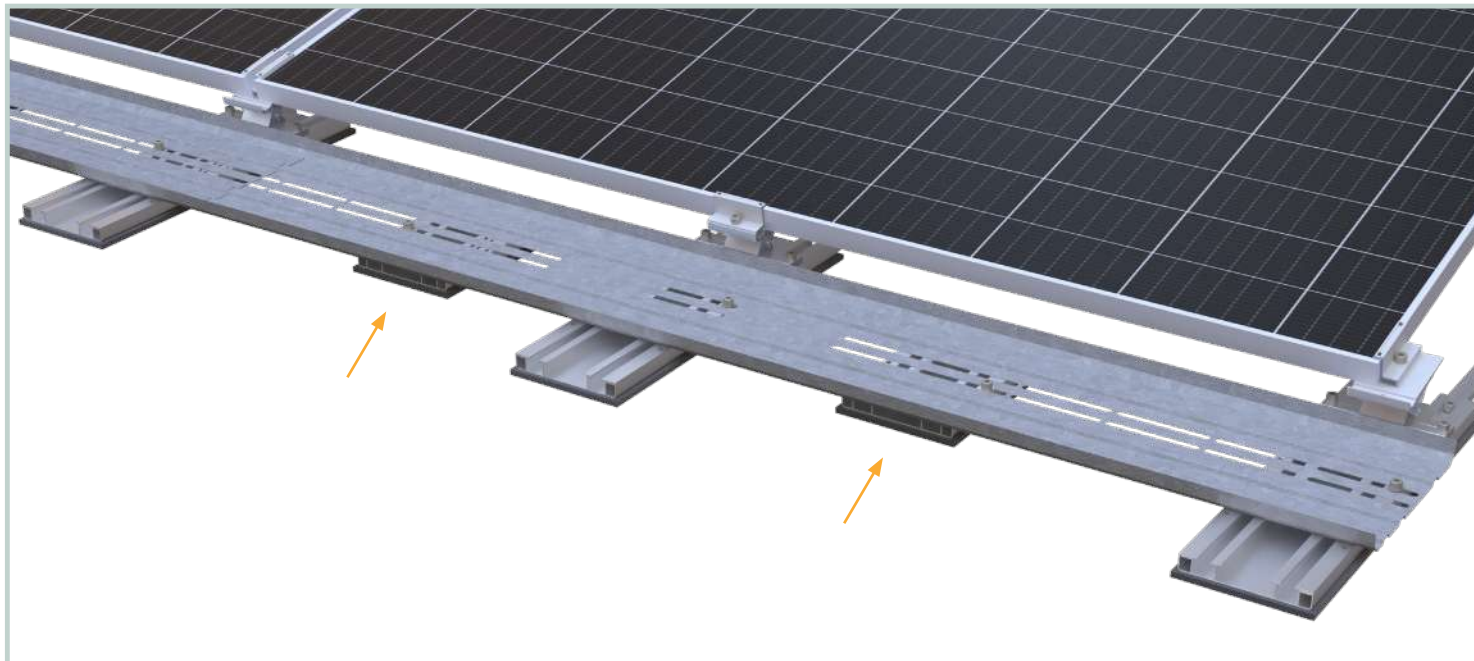

LIGHTNING PROTECTION

INTEGRATION OF EASYSPEED 2 INTO LIGHTNING PROTECTION CONCEPT

General Information

A qualified lightning protection technician must be involved in the planning and installation of the system. The decision about if and how the module array can be integrated into the lightning protection concept rests exclusively with this qualified technician.

The easySPEED 2 system has been successfully tested for lightning current carrying capacity of 50 kA (Class N) and for requirements related to potential equalization per DIN EN IEC 62561-1 and DIN EN 61439-1.

We recommend using the UNI grounding clamps from Dehn for the lightning protection connection. These can be optimally attached to the base plates of the system using hammerhead bolts.

Lightning Current Carrying Capacity

The H-rail must be installed continuously along the longitudinal axis of the module array (see blue highlighted line). This ensures a permanent and uninterrupted electrical connection in the longitudinal direction.

To guarantee the lightning current carrying capacity of the entire module field, a transverse electrical bond must also be provided. This can be achieved either through the profile brackets with cross rails, via the ballast trays, or by an equivalent bonding method provided on site (see red highlighted line).

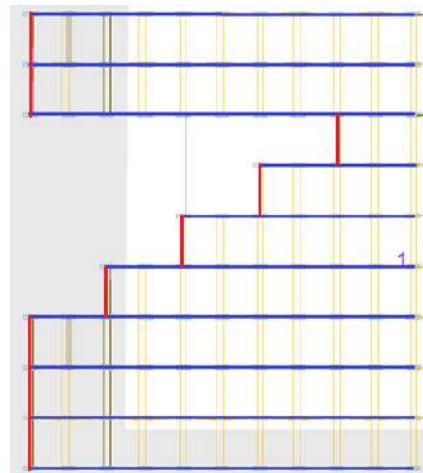

LIGHTNING PROTECTION

INTEGRATION OF EASYSPEED 2 INTO THE LIGHTNING PROTECTION CONCEPT

Potential Equalization – Installation and Connection

Potential equalization is achieved via the grounding pins, which reliably penetrate the anodized coating of the module frames upon installation, ensuring electrical contact.

Verification and Test Documents

A general confirmation of the lightning current carrying capacity of the easySPEED 2 system is available for download on our website at www.alumerogroup.eu.

For access to the detailed test documents, please contact your responsible customer consultant.

PLEASE NOTE THE FOLLOWING ADDITIONAL DOCUMENTS!

The following documents are required in addition to the installation manual for the correct assembly of the system:

- + Project Report from ALUMERO SOLAR.PRO.TOOL
- + Planning documents and drawings
- + The general "Installation Notes" document available at <https://www.alumerogroup.eu/service> under "General" -> "Other"

Please also review the safety regulations of the other system components.

CONGRATULATIONS, WELL DONE!



**SUSTAINABLE
SOLAR
SOLUTIONS**

ALUMERO Systematic Solutions GmbH
Sonnenweg 1-2 | 5162 Seeham - Österreich
+436217 / 68 41 - 0
alumero@alumero.at | www.alumero.at