

Real-time Grid Visibility Starts Here

Monitoring. Predicting. Optimizing.
All from the conductor.



SENTRISENSE
a Megger Company®

sentriseNSE.com

Sentrisense helps utilities monitor the unmonitored

We deliver real-time insights from power lines—directly from the conductor—enabling smarter decisions and safer, more efficient grids.

Founded in 2020, we specialize in autonomous field devices for overhead lines. Our **SENTRI** sensor is installed in multiple countries and trusted by grid operators to detect risk, improve ampacity, and extend asset life.

Whether you're managing extreme weather, increasing demand, or aging infrastructure, we give you the visibility to act—without assumptions.

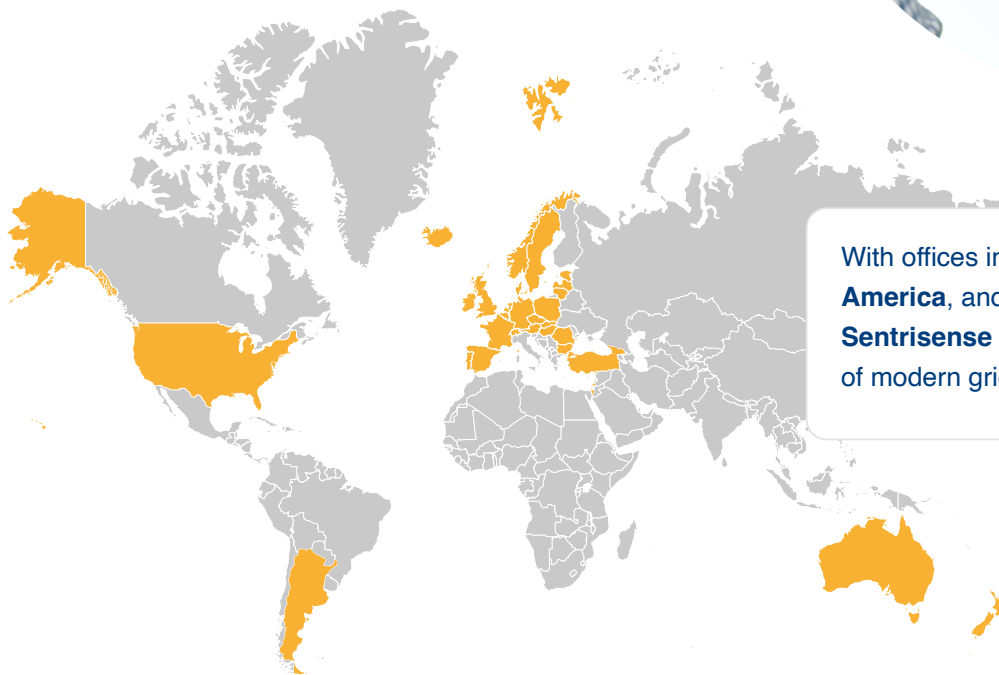

With offices in **Europe and South America**, and now as a **Megger** company, **Sentrisense** is helping to shape the future of modern grid management.

Trusted By



Sentri 4.0

Smart grid low, medium, and high voltage sensor

SENTRI is a wireless online monitoring system for any kind of overhead power line—including AC, DC, grounding, and neutral conductors.

Built for harsh environments, **SENTRI** installs directly on energized conductors using a drone, hot stick, or insulated gloves. Once deployed, it connects automatically, self-configures, and begins streaming data—no external routers, RTUs, or manual setup required.

Its hybrid architecture supports both real and virtual sensing. Data is transmitted periodically (e.g. every 15 minutes) and accessible via cloud or API.

SENTRI is fully autonomous, solar-powered, and operates with cellular or Wi-Fi (direct or through satellite) fallback. Two configurations are available for different conductor diameters:

- 4–16 mm
- 10–70 mm

This is visibility where it matters most—right at the grid edge.



What SENTRI Measures

Variable

Line Temperature

Current (A)

Inclination & Sag

Vibration Frequency

Purpose

Helps to improve ampacity and overheating risks

Real-time load measurement

Detects structural strain or anomalies

Flags fatigue, galloping, or wire theft

*For voltage measurement please contact us

Sentri 4.0

Smart grid low, medium, and high voltage sensor

SENTRI was designed to solve real problems on the grid—where faults escalate fast and visibility is often limited. These four applications reflect how SENTRI is used today by grid operators worldwide to monitor critical assets, prevent outages, and operate more confidently under pressure.

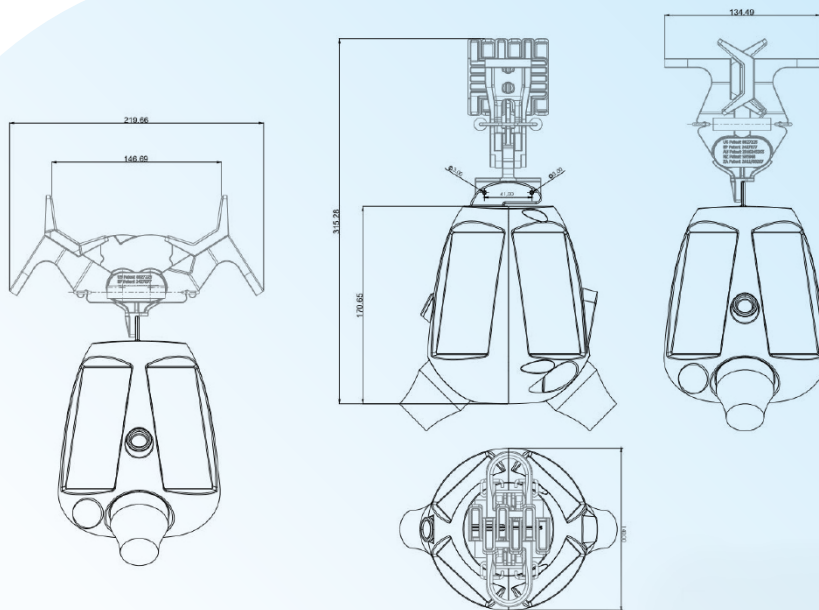

Dynamic Line Rating (DLR)

Continuously calculates line ampacity based on real conditions—temperature, current, sag, and weather. **SENTRI** supports short-term, forecast, and steady-state ampacity calculations.

Incident Detection

Instant notifications when critical thresholds are exceeded. Includes alerts for faults, overloads, excessive vibration, and other disruptive events.

Asset Health Monitoring

Identifies anomalies such as unusual sag, vibration, or inclination—allowing operators to detect risks before they escalate into failures or outages.

Pole & Tower Monitoring

Monitors tower inclination (e.g., scoliosis), structural fatigue, or mechanical changes over time—crucial for tower health assessment and prevention of collapses or sabotage.

Services & Integration

More than a sensor. A complete monitoring system.

SENTRI is designed to be deployed, scaled, and integrated with minimal friction. Whether you're looking to test DLR on a single line or monitor hundreds of towers across a region, our team provides the tools and support to make it happen.



Deployment Support

We provide drone installation, training, and assistance to ensure your first deployment is fast and reliable—no specialized equipment or crew needed.



Platform Integration

SENTRI integrates with SCADA, EMS, or third-party platforms via REST API, Modbus TCP/IP, or secure MQTT. No custom middleware required.



Cloud Dashboard (optional)

View real-time metrics, download historical data, configure alerts, and visualize asset health—all in a secure web-based interface.



Hybrid Configuration

Choose between sensor-based or sensorless DLR setups. SENTRI can be deployed in mixed configurations across the same network.



Cybersecurity Standards

Zero-trust architecture and secure authentication protocols protect all communications—from sensor to cloud.

Technical Data

TECHNICAL DATA

Installation options and power line parameters

Installation options	Drone Grip-all hot-stick Insulated gloves
Conductor diameter	6 - 70 mm
Conductor configuration	Single / Bundle
Line voltage	
DC	0 to 500 kV ph-to-ph
AC	0 to 420 kV ph-to-ph
Conductor temperature	235 °C Max

CONTROL INTERFACES

Led indication	Indicates status
Push button	Controls power

POWER OPTIONS

Power Feeding	Solar energy
Typical Battery Life	10-20 years
Remote configuration	All sensor variables can be configured. Firmware can be updated over-the-air
Measurement interval	Each 15 minutes typical (programmable)
Alerts	Threshold (all variables) Silence (device not reporting) Movement (wire theft and specific patterns) Low battery

PHYSICAL AND ENVIRONMENTAL

Chassis body dimensions	12.1 x 14.0 x 21.3 cm (4.76 x 5.51 x 8.38 in)
Casing	Aluminum, Body: IP66
Temperature range	-40 °C to +70 °C

CELLULAR COMMS	LTE -TDD B34/B38/B39/B40/B41 LTE-FDD B1/B2/B3/B4/B5/B7/B8/B12/B13 B18/B19/B20/B25/B26/B28/B66 UMTS/HSPA + B1/B2/B4/B5/B6/B8/B19 GSM/GPRS/EDGE 850/900/1800/1900 MHz
-----------------------	---

Cyber Hardening End-to-end TLS/SSL, certificates enrollment, private APN, encrypted firmware upload, several levels of local access permission

DIRECT MEASUREMENTS

Conductor current

- Units: A
- Range: 5–5500 A
- Resolution: 1 A
- Accuracy: ±2%

Conductor temperature

- Units: °C
- Range: –40°C to 230°C / -40°F to 446°F
- Resolution: 1°C
- Accuracy: ±5%

Conductor frequency of vibration [Hz]

- Range: 3–150 Hz
- Error: ±1%
- Sensitivity: 1 Hz

Conductor vibration amplitude [mm]

- Error: ±1%
- Sensitivity: 1 mm

Roll / Tilt

- Units: °
- Range: –90° to +90°
- Resolution: 0.01°
- Accuracy: 0.20°

Sag

- Units: m
- Resolution: 0.01 m
- Accuracy: ±3%

Transversal wind speed

- Units: m/s
- Range: 0–7 m/s
- Resolution: 0.01 m/s
- Accuracy: ±3%

INDIRECT MEASUREMENTS

Ampacity [A]

Sag [m]

Wind speed [m/s]

Bending amplitude [mm], Conductor fatigue [%]

What Makes SENTRI Different?

SENTRI was designed from the ground up to overcome the limitations of traditional power line monitoring. From its self-sufficiency in the field to its real-time intelligence, here's why grid operators choose SENTRI.



- ✔ True Field Autonomy: No routers. No towers. No local infrastructure. SENTRI connects itself, calibrates itself, and starts sending data—immediately.
- ✔ Instant Deployment: Install in under 5 minutes using a hot-stick, gloves or drone. No shutdown required. No tools needed.
- ✔ Resilient by Design: Solar-powered with backup battery. Operates 24/7, rain or shine, from -40°C to $+85^{\circ}\text{C}$.
- ✔ Scalable Intelligence: From one line to your entire grid—our platform grows with you.
- ✔ Hybrid Architecture: Use virtual sensors, physical sensors, or combine both—adapting to your budget, terrain, and urgency.
- ✔ Extreme Compatibility: AC. DC. Neutral. Ground. SENTRI fits anywhere on your grid—on conductors or directly on towers.
- ✔ One Device, Multiple Applications: From Dynamic Line Rating (DLR) to tower tilt and vibration monitoring—SENTRI does it all.
- ✔ Trusted by Grid Operators Worldwide: Validated in real conditions with ELIA (Belgium), Transelec (Chile), Powerco (New Zealand), and more.

Want to see what SENTRI can do for your grid?

Let's talk.

www.sentrise.com

info@sentrise.com

Our Offices

North America:

☎ +1 360 312 7562

Europe:

☎ +34 66 999 0195

South America:

☎ +54 911 3452 8727

 [sentrise](https://www.linkedin.com/company/sentrise)



SENTRISENSE
a Megger Company®