

Irrational Behaviours (not ours) and human errors

Professor Sameh ABADIR

Warsaw, March 2026

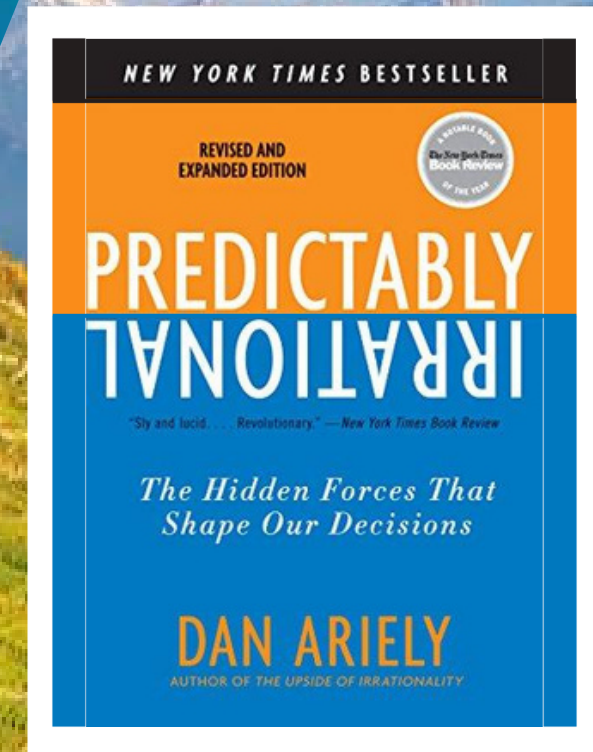



You're four times
It's hard to
more likely to have
concentrate on
a road accident
two things
when you're on
at the same time.
a mobile phone.



Prospect Theory

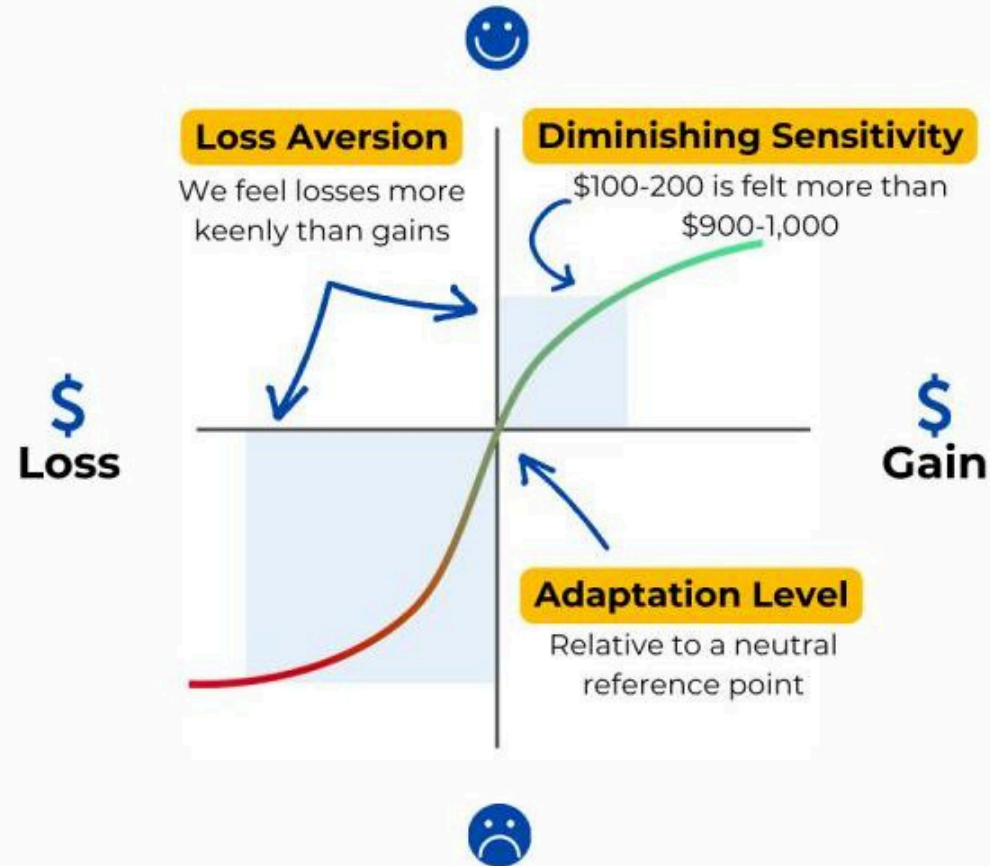

Which is longer?

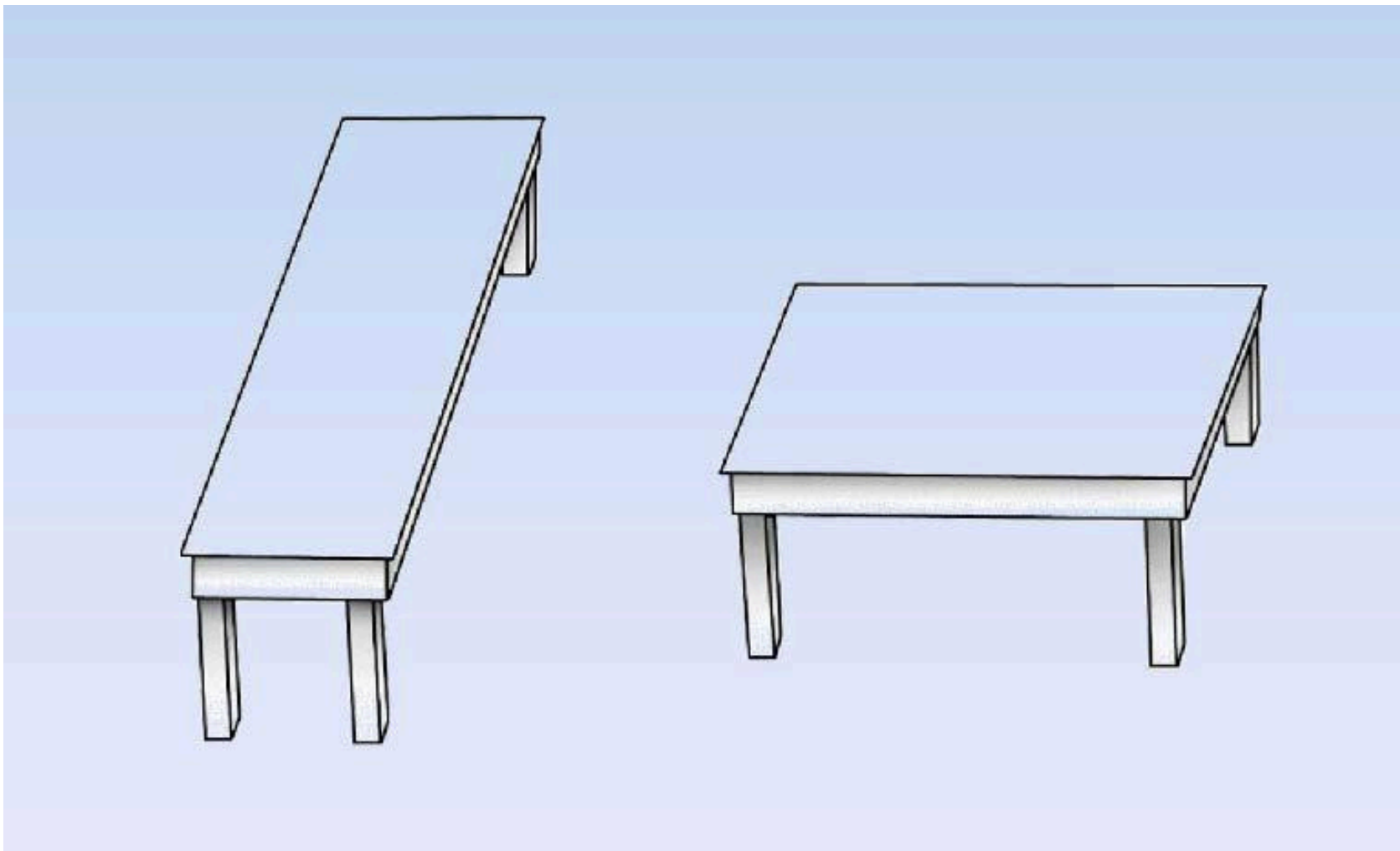

Which is longer?

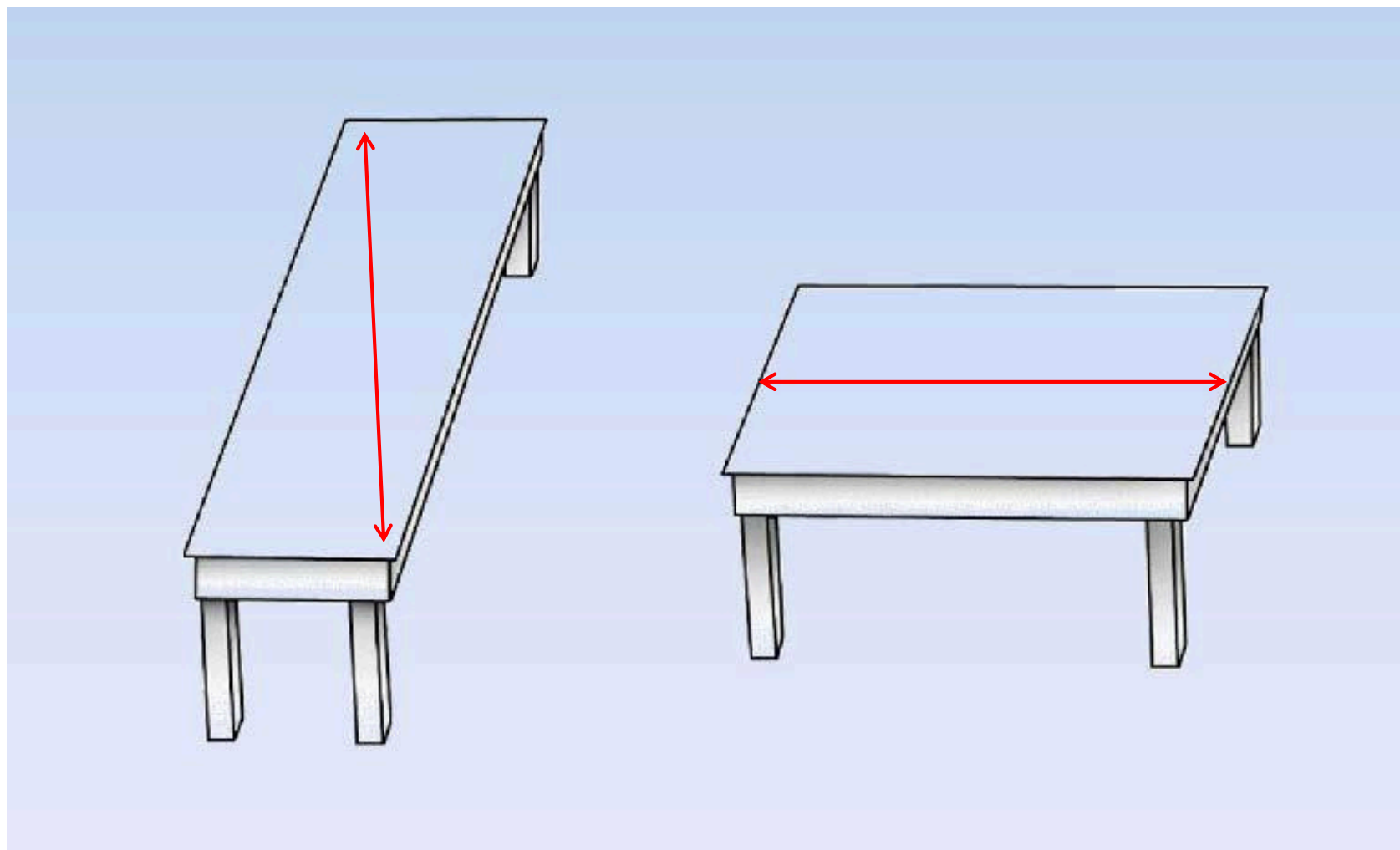

Which is longer?

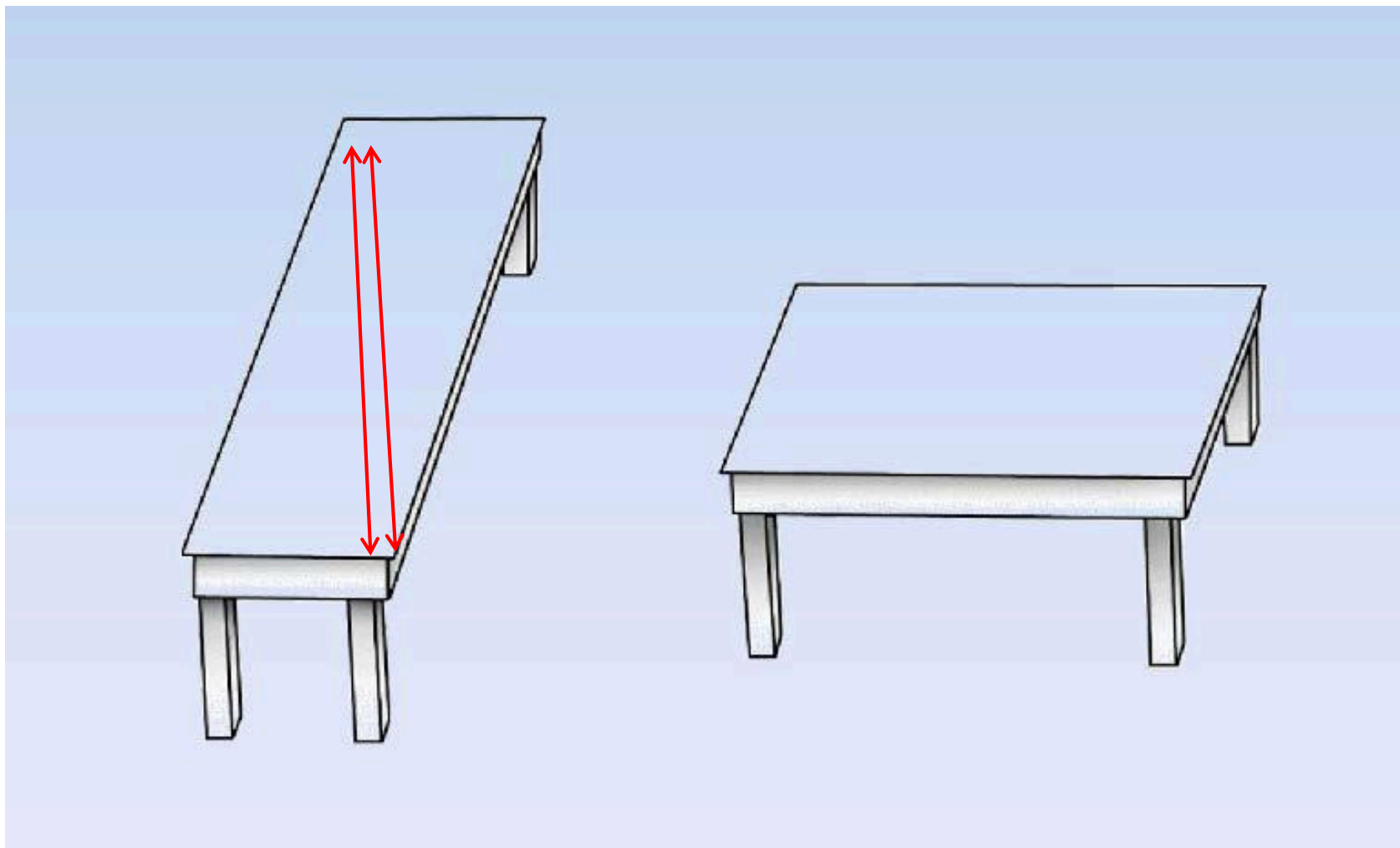

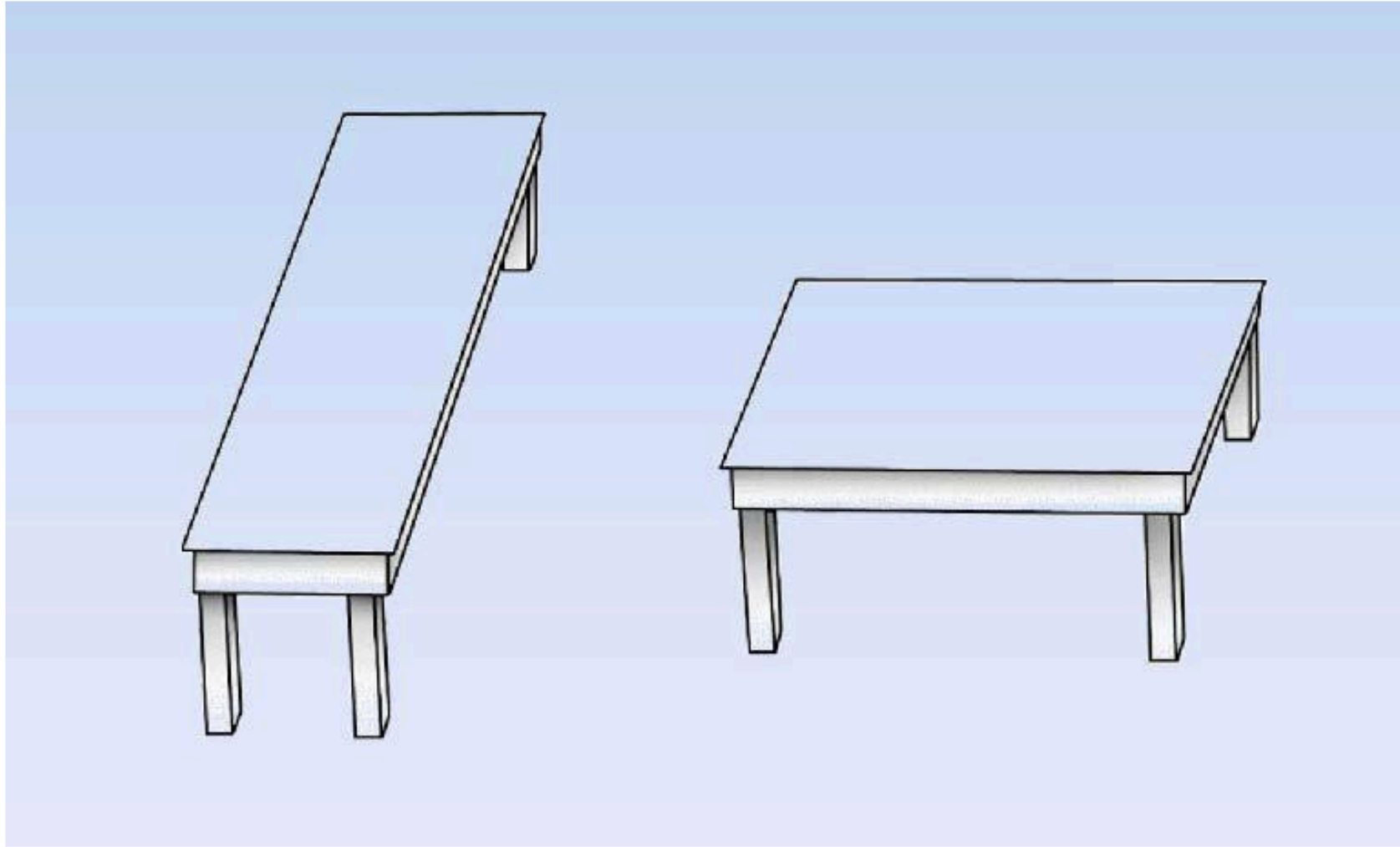

Who is happier?

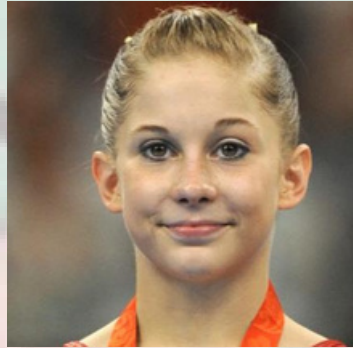
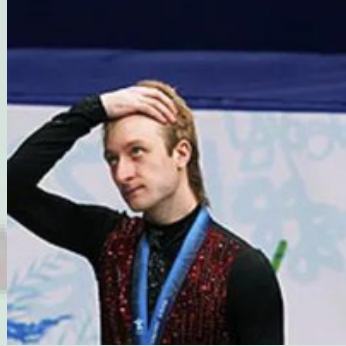

Who's Happier?



The discount: Computers vs. Calculators

You're buying a computer – it is priced at 2000€
BUT the salesperson is a friend of yours and gives you a tip: the computer is on sale in a shop 20-minute drive away.

Q: What kind of discount would make it worth a 20-minute drive?

You're buying a calculator – it is priced at 50€
BUT the salesperson is a friend of yours and gives you a tip: the calculator is on sale in a shop 20-minute drive away.

Q: What kind of discount would make it worth a 20-minute drive?



The hotel experience

The 100% perfect experience
(where NOTHING at all went wrong)

VS

The very good experience
The very good experience
(where a tiny issue came up BUT was fixed on
the spot)



Economist.com	SUBSCRIPTIONS
OPINION	Welcome to
WORLD	The Economist Subscription Centre
BUSINESS	Pick the type of subscription you want to buy or renew.
FINANCE & ECONOMICS	<input type="checkbox"/> Economist.com subscription - US \$59.00
SCIENCE & TECHNOLOGY	One-year subscription to Economist.com. Includes online access to all articles from <i>The Economist</i> since 1997.
PEOPLE	<input type="checkbox"/> Print subscription - US \$125.00
BOOKS & ARTS	One-year subscription to the print edition of <i>The Economist</i> .
MARKETS & DATA	<input type="checkbox"/> Print & web subscription - US \$125.00
DIVERSIONS	One-year subscription to the print edition of <i>The Economist</i> and online access to all articles from <i>The Economist</i> since 1997.

32%

68%



Economist.com	SUBSCRIPTIONS
OPINION	Welcome to
WORLD	The Economist Subscription Centre
BUSINESS	Pick the type of subscription you want to buy or renew.
FINANCE & ECONOMICS	<input type="checkbox"/> Economist.com subscription - US \$59.00
SCIENCE & TECHNOLOGY	One-year subscription to Economist.com.
PEOPLE	Includes online access to all articles from <i>The Economist</i> since 1997.
BOOKS & ARTS	<input type="checkbox"/> Print & web subscription - US \$125.00
MARKETS & DATA	One-year subscription to the print edition of <i>The Economist</i> and online access to all articles from <i>The Economist</i> since 1997.
DIVERSIONS	

74%

26%

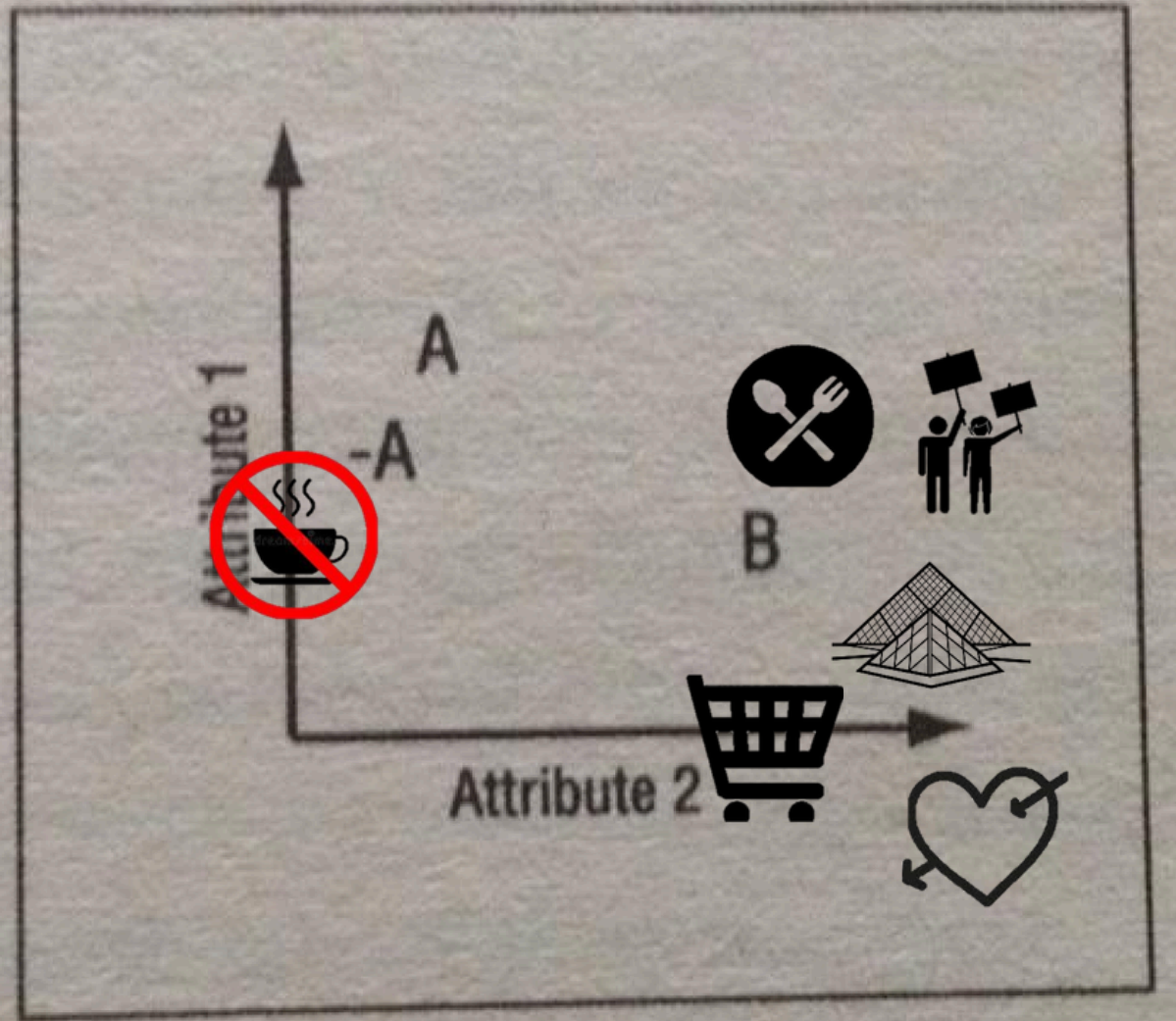
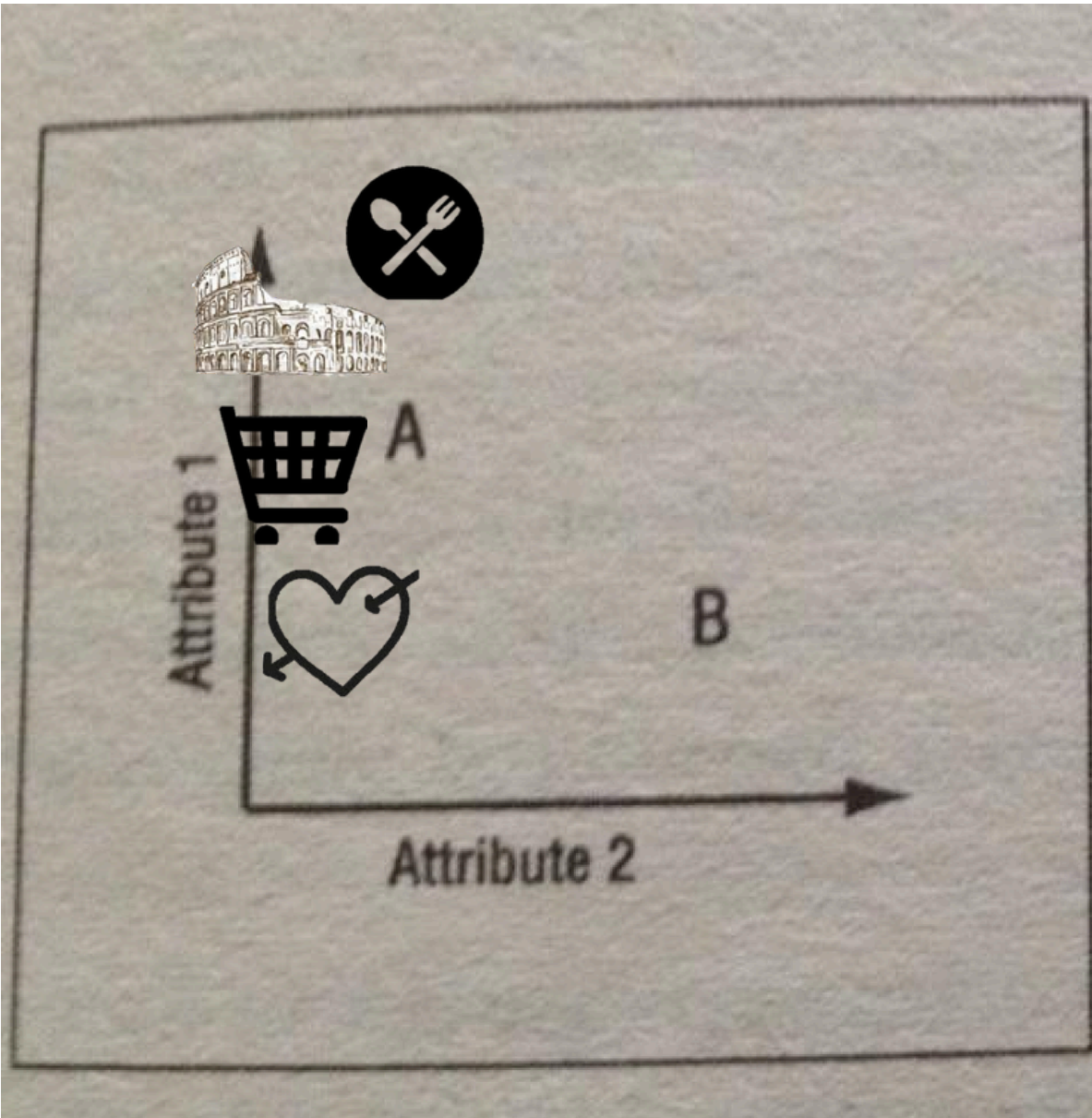

Economist.com	
SUBSCRIPTIONS	
OPINION	Welcome to
WORLD	The Economist Subscription Centre
BUSINESS	Pick the type of subscription you want to buy or renew.
FINANCE & ECONOMICS	<input type="checkbox"/> Economist.com subscription - US \$59.00
SCIENCE & TECHNOLOGY	One-year subscription to Economist.com.
PEOPLE	Includes online access to all articles from <i>The Economist</i> since 1997.
BOOKS & ARTS	<input type="checkbox"/> Print subscription - US \$125.00
MARKETS & DATA	One-year subscription to the print edition of <i>The Economist</i> .
DIVERSIONS	<input type="checkbox"/> Print & web subscription - US \$125.00
	One-year subscription to the print edition of <i>The Economist</i> and online access to all articles from <i>The Economist</i> since 1997.

32%

68%

Economist.com	
SUBSCRIPTIONS	
OPINION	Welcome to
WORLD	The Economist Subscription Centre
BUSINESS	Pick the type of subscription you want to buy or renew.
FINANCE & ECONOMICS	<input type="checkbox"/> Economist.com subscription - US \$59.00
SCIENCE & TECHNOLOGY	One-year subscription to Economist.com.
PEOPLE	Includes online access to all articles from <i>The Economist</i> since 1997.
BOOKS & ARTS	<input type="checkbox"/> Print & web subscription - US \$125.00
MARKETS & DATA	One-year subscription to the print edition of <i>The Economist</i> and online access to all articles from <i>The Economist</i> since 1997.
DIVERSIONS	

74%

26%

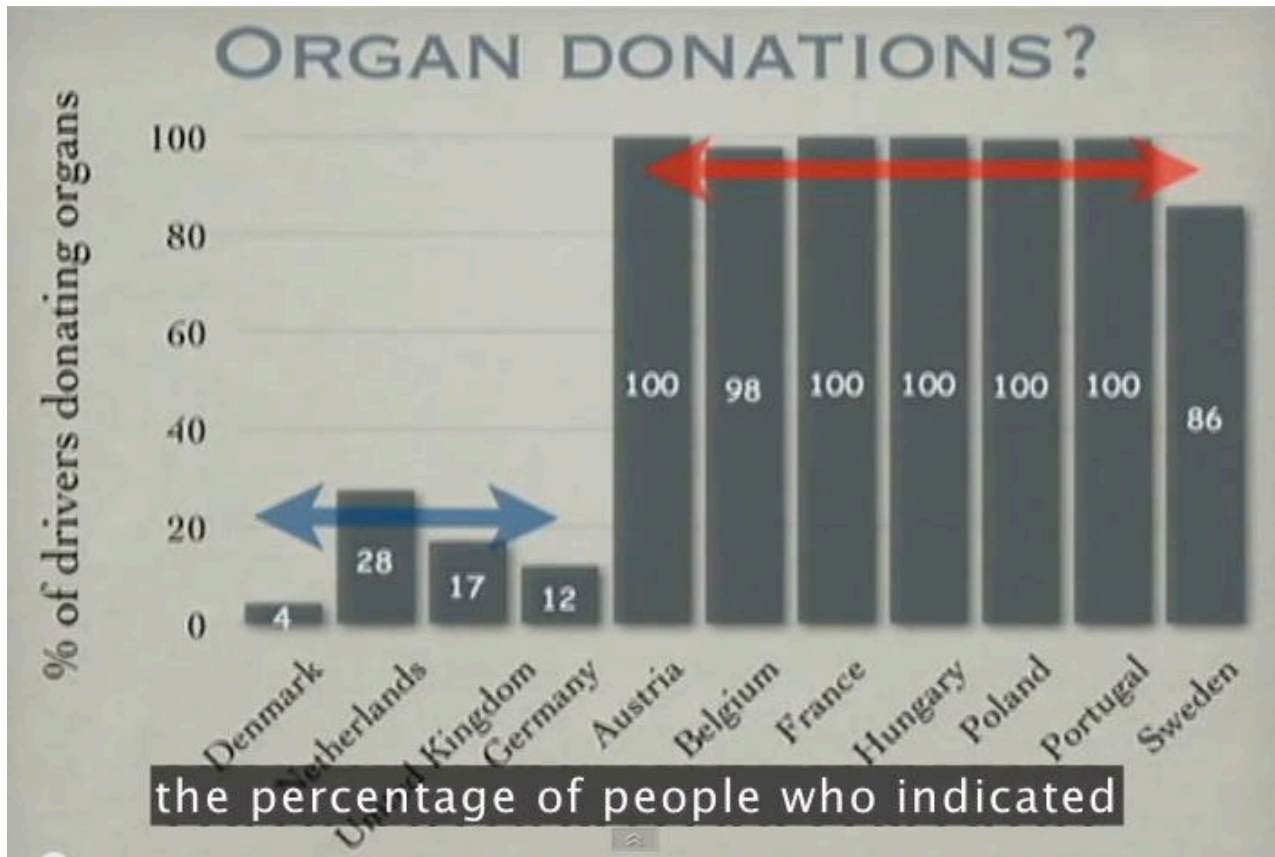

Opt-in

Check the box below if you **want** to participate in the organ donor program

The countries on the left have a form at the DMV

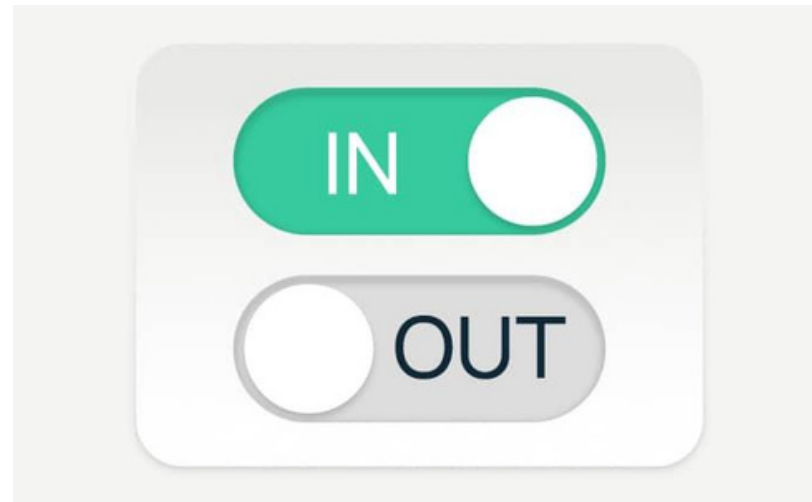

Opt-in

Check the box below if you **want** to participate in the organ donor program

people don't check the box -- and don't join

Opt-out

Check the box below if you **don't want** to participate in the organ donor program

Interestingly enough, when people get this,

Opt-in

Check the box below if you want to participate in the organ donor program

~~people don't check the box -- and don't join~~

Opt-out

Check the box below if you don't want to participate in the organ donor program

~~people don't check the box -- and join~~



So why do – some - smart
people take bad decisions ?