

StarCycler 101

Proving the StarCycler

m

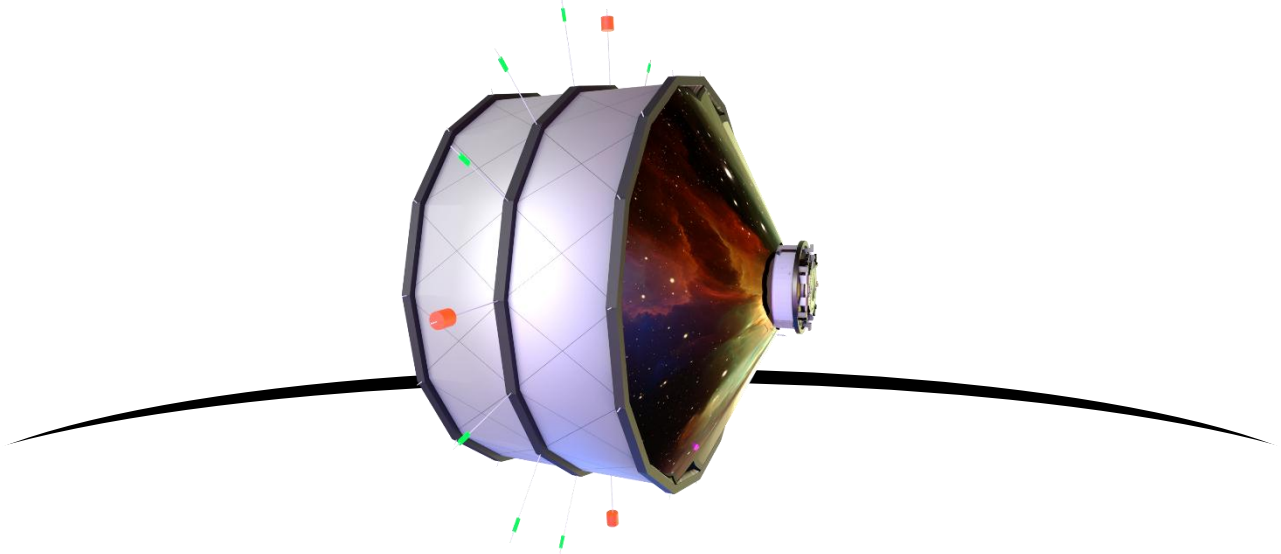

A Wide-Profile Architecture
for Artificial Gravity

STARCYCLER
AEROSPACE

www.starcycler.com
sales@starcycler.com
Edward Dooner, CEO
215-873-4263

StarCycler: A Wide-Profile Architecture for Artificial Gravity

Executive Summary (2016–2025 Progress, 2026–2035 Outlook)

Artificial gravity is a central requirement for long-duration human presence in space, yet conventional rotating habitat designs impose significant constraints on size, constructability, and operational control. These limitations are largely driven by reliance on narrow toroidal geometries to maintain passive gyroscopic stability.

StarCycler introduces an alternative architectural approach based on controlled internal momentum management rather than strict dependence on passive stability. By redistributing mass and angular momentum within the system, rotational equilibrium can be actively maintained, enabling wider and more structurally practical configurations.

The resulting architecture adopts a semi-stable, wide-profile geometry (on the order of 150 ft diameter), operating at moderate rotation rates (~5.2 rpm) to produce approximately 0.7g at the perimeter. This configuration significantly increases usable volume while remaining within established physiological tolerance ranges.

Central to the design is a coordinated system of internal mechanisms that regulate the station's momentum profile:

- Mobile mass systems that dynamically balance rotational asymmetries
- Internal momentum reservoirs for energy and angular momentum exchange
- A centralized control system (GEM: Gyro/Electro/Momentum) for spin regulation and orientation

These systems allow the habitat to function as a controlled isolated system governed by conservation of energy and angular momentum, while remaining responsive to internal mass redistribution and operational demands.

Development from 2016 to 2025 established the foundational principles of spin-balancing and defined the architectural framework for a wide rotating habitat. Analytical modeling and early prototyping efforts have focused on validating internal momentum exchange and control behavior.

The architecture supports a stratified internal environment with multiple gravity levels, ranging from microgravity at the core to partial gravity at the perimeter. This enables co-located habitation, research, manufacturing, and environmental systems within a single structure.

From 2026 to 2035, development priorities shift toward system validation and demonstration, including physical prototypes, expanded simulation and engineering analysis, and engagement with external technical reviewers.

By reframing the relationship between stability and controllability, StarCycler presents artificial gravity as an achievable engineering solution, with a pathway toward scalable, habitable rotating systems.

PHYSIOLOGY

75 ft radius @ 5.2 rpm = 0.7 AG

The design is driven by human physiology.

In the vast expanse of space, the human body grapples with a myriad of physical challenges most of which can be mitigated through the implementation of Artificial Gravity (AG).

Coriolis

This graph is a standard in peer-reviewed papers discussing the physiological response from the Coriolis effect in rotating environments.

Compiled by Cool Worlds, this graph is the most comprehensive to date, viewing their full video is highly recommended.

The rotation rate is the critical element with six rpms being the upper limit for most people. However, in a practical sense, an adaptability line exists within the Comfort Zone and may extend to faster rpm.

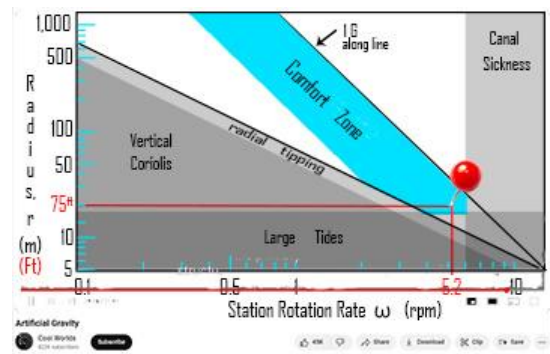

Full Video:

<https://youtu.be/b3D7QIMVa5s>

Other Ailments

At this point, the critical elements in determining the station size are the AG produced and constructability. Empirical evidence to determine the optimum AG for addressing other physiological challenges can only be obtained onsite in space, which the station's variable speed can address. Nevertheless, the primary concern remains the reacclimatization upon return to Earth.

For construction purposes, we begin with the smallest diameter within the comfort zone to assess its feasibility. A station with a 75-foot radius would require 60-foot beams or spokes if assembled atop the booster fuselage. This approach would significantly simplify space construction.

A 75 ft radius station rotating at 5.2 rpm would produce 0.7 g (70%) of Earth's gravity. This level of AG is significant and well within the comfort zone, effectively mitigating most physiological challenges, except for Coriolis effects. The return to Earth would feel akin to carrying a heavy backpack. Additionally, at this size, it becomes feasible to enclose the entire environment, facilitating the creation of multiple gravity zones.

SIZE AND SHAPE

½ width x diameter

75' width x 150' dia.

A 75 ft radius station is feasible; however, in a toroidal configuration the usable habitable volume remains limited at comparable scales, reducing its economic and practical viability. In contrast, the StarCycler architecture provides approximately 2 million cubic feet of habitable volume while maintaining ~0.7g at the perimeter.

The current concern regarding wider rotating habitats stems from the potential loss of gyroscopic stability. StarCycler reframes this constraint by identifying a key design trade-off: as gyroscopic stability increases, controllability correspondingly decreases—an effect that directly influences architectural choices.

Expanding the station's width necessitates a counterbalance system. Conversely, any control system will necessitate a wider station.

Since an equal width x diameter shape is the most unstable, opting for a semi-stable shape of ½ width x diameter emerged as the most logical configuration to reduce the demand on the spin balance system.

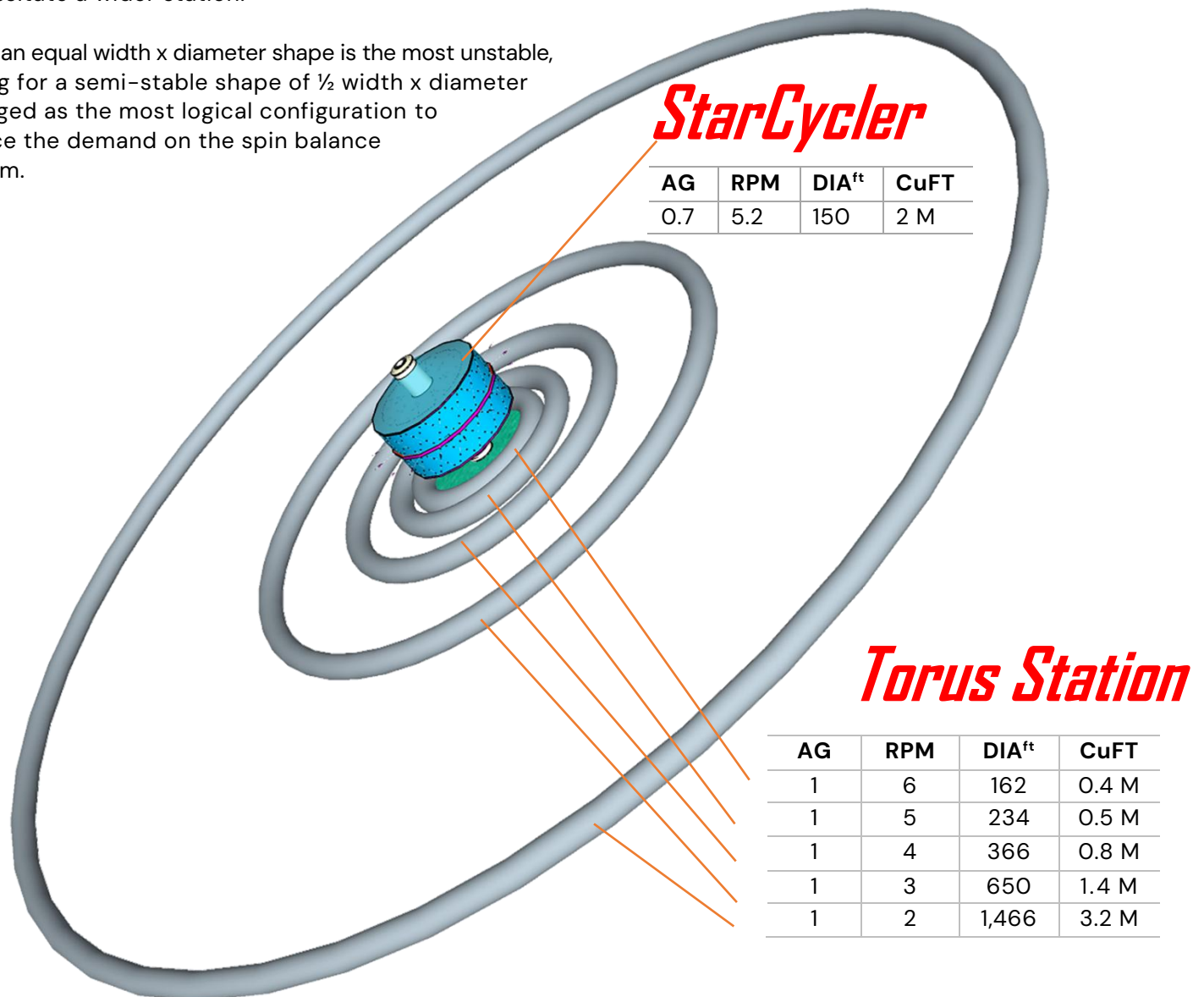

STRUCTURE

Spokes – Inflatable – Booster Fuselage

The booster fuselage serves as an ideal foundation to build upon and provides habitation during construction.

The **Tensegrity Spoke System** effortlessly pops up into a large, force-distributive structure.

The geodesic structure functions as a suspension bridge, effectively managing torsional, and stabilizing forces.

A sectional inflatable serves as an ideal solution for providing the initial layer to enclose the bio-environment.

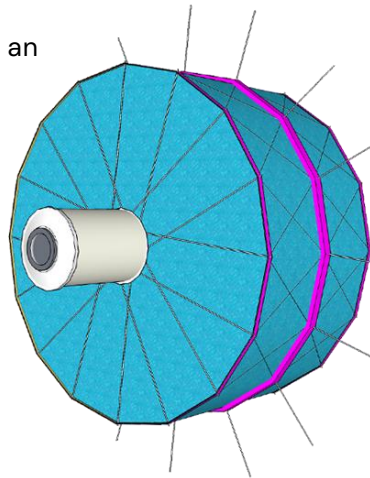
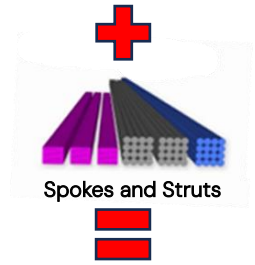
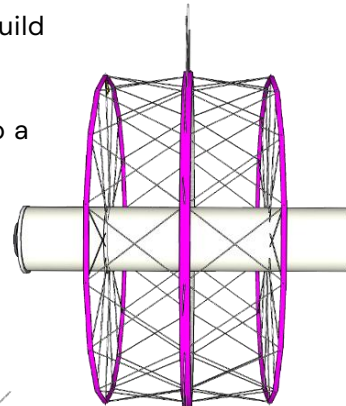
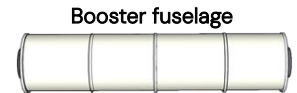

YOU ARE HERE

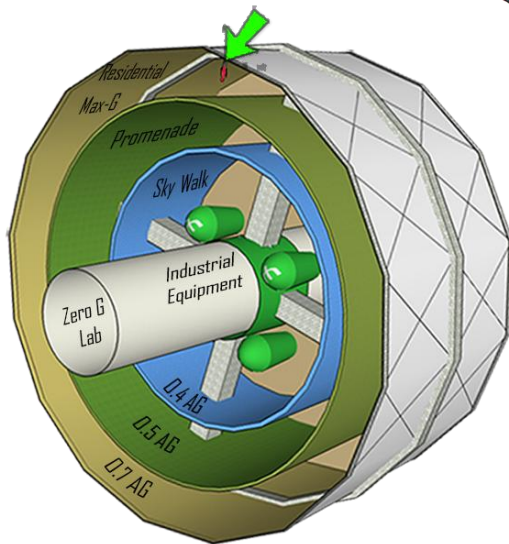

BIO HABITAT

Residence

A StarCycler offers 2 million cubic feet of breathable atmosphere with various AG gradients.

The structure comprises five floors, each 15 feet apart, incorporating two free-floating Atriums (not depicted) and elevator service to the zero-G core.

To optimize the station's momentum profile, the outermost floor remains lightweight, while heavy machinery is concentrated along the centerline, near the core.

Frames of References

Floor	AG @ 5.2 rpm	Name	Purpose	Floor Area (Sq Ft)
5	~0.7g	Residential	Housing and other light weight amenities	35,000
4	~0.55g	Promenade	Open air for gatherings and shops	28,000
3	~0.4g	Sky Walk	Environmental system wind, filtration, rain	21,000
2	~0.27g	Infrastructure	Large tanks, heavy machinery - "Inertia Ballast"	-
1	~0 to 0.13G	Inside Core	Zero G lab, Docking port, Navigation room	-
Bow	Free Floating	Atrium	Equipment room and wet wall	-
Aft	Free Floating	Atrium	Transparent enclosure, Recreational	-

MOMOX

Motion \rightleftharpoons Momentum Exchange Engine



wRover

Spin balancing the station is achieved using mobile weights known as wRovers. These wRovers travel throughout the station on a looped webbed track, exchanging Motion \rightleftharpoons Momentum, thereby keeping the momentum profile radially balanced.

The robust elevator system will facilitate most of the transference, keeping stress loads localized

GEM

Gyro / Electro / Momentum Motor

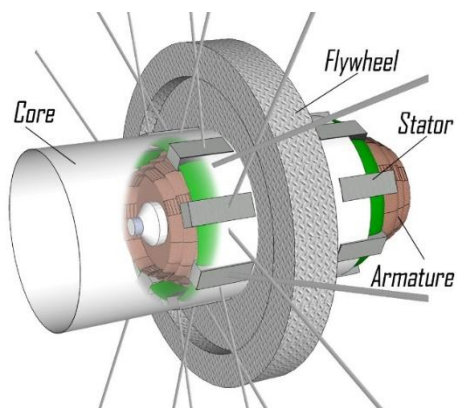

GEM is central to the StarCycler design. On a rotating craft, the center of mass is the only location where a Control Moment Gyro (CMG) can operate without inducing destabilizing torques during reorientation.

Positioned at the center, GEM exchanges momentum internally with the station, while its gyroscopic response is defined relative to the station's rotating frame. This distinction enables spin control, stabilization, and reorientation through its independent axis.

wRovers names change pending location

GyroRudder

momoX

SpeedMoR Reservoir

SloMor Reservoir

Elevator System

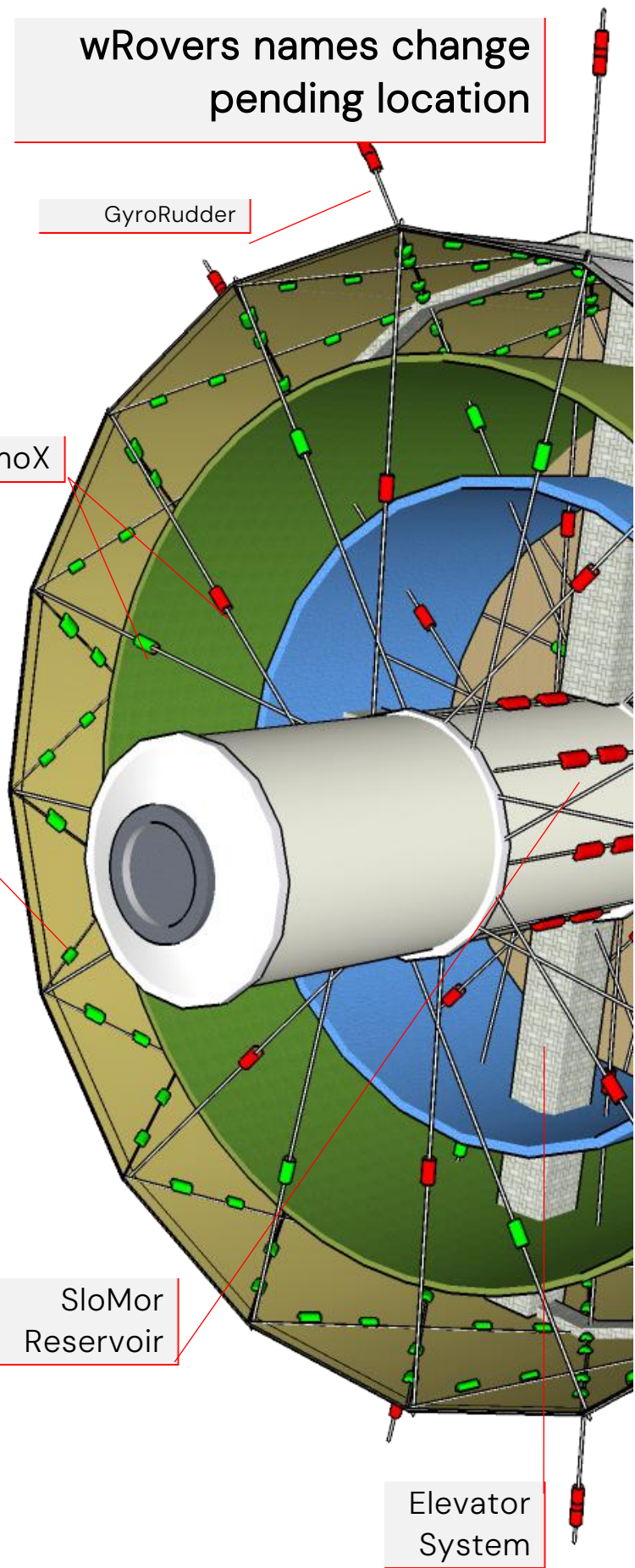

PHYSICS

Motion Mechanic

According to the Laws of Conservation
A StarCycler exemplifies an Isolated Physical System where energy, in the form of momentum, is dynamically linked to the motion of mass.

" This energy remains constant, interchanging but never diminishing."

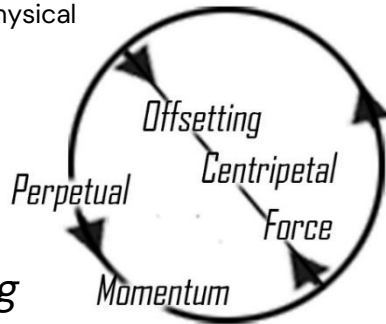

Artificial Gravity

A continuous change in motion of mass can simulate gravity, and remarkably, a rotating environment can provide this change while conserving angular momentum.

Motion is largely imperceptible, while artificial gravity is ever-present. However, momentum continuously redistributes as mass and passengers move throughout the station, altering structural loads and the overall momentum profile.

Momentum Profile

It is the rotational momentum profile, rather than the station's physical shape, that governs system behavior.

The SpeedMoR reservoir, in conjunction with the GyroRudder, enables controlled transitions between maneuverable and gyroscopically stable states.

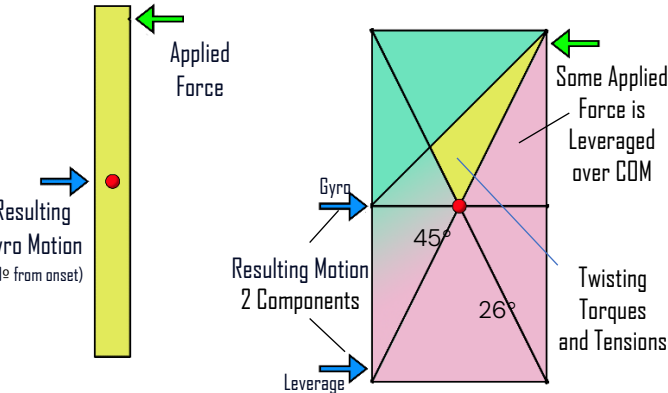
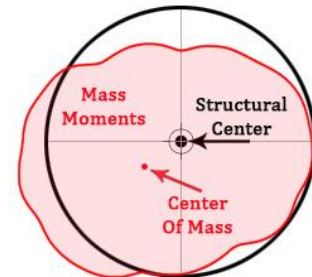

Rotation

Rotating mass displays unique characteristics determined by the momentum profile. A thin disc, for example, exhibits angular momentum that generates a gyro stabilization torque, effectively resisting external impulses and potentially nullifying control systems.

The wider shape of the StarCycler mitigates this force by repositioning the Center of Mass within a structure capable of redistributing reorientable force loads.

Relative Angular Momentum - GEM vs. Station

Station Mass Distribution
~9,200 slugs at center of mass
(equivalent representation)

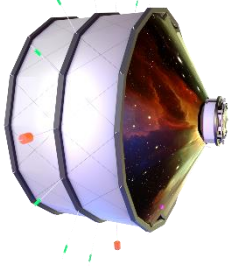

(~300,000 lb system mass)

In the absence of external torques, the StarCycler conserves angular momentum, while GEM—operating as an independent system at the center of mass—enables controlled redistribution of momentum within the overall system.

The interaction between distributed station momentum and centralized control momentum is fundamental to StarCycler's operation. These figures illustrate the distinction between the station's distributed angular momentum and GEM's concentrated, controllable momentum at the center of mass.

GEM Angular Momentum
~14,500 lb-ft (representative)

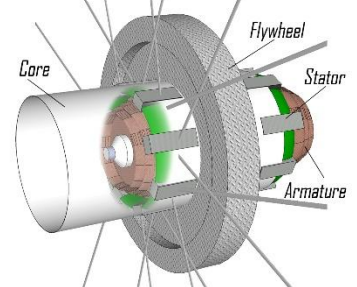

(15,000 lb, 30 ft Diameter, 20 rpm)

Centralizing controllable momentum at the center of mass enables reorientation and stabilization without compromising the distributed mass required for artificial gravity.

ROCKET

Launch and Deployment Considerations

A primary design objective of StarCycler is minimizing in-space construction by deploying a pre-configured structural framework that forms a usable enclosed environment upon deployment.

External propellant tanks and structural elements are retained for post-insertion repurposing, supporting early-stage infrastructure such as bio-habitat, shielding, and system integration while reducing overall launch mass.

This approach aligns launch architecture with on-orbit utility, reducing the complexity traditionally associated with large rotating habitats.

Reusable
Core and Tanks

Payload
Inflatable
Spokes
GEM
175,000 lbs
(estimate)

**Effective weight
to Low Earth Orbit
300,000 lbs**

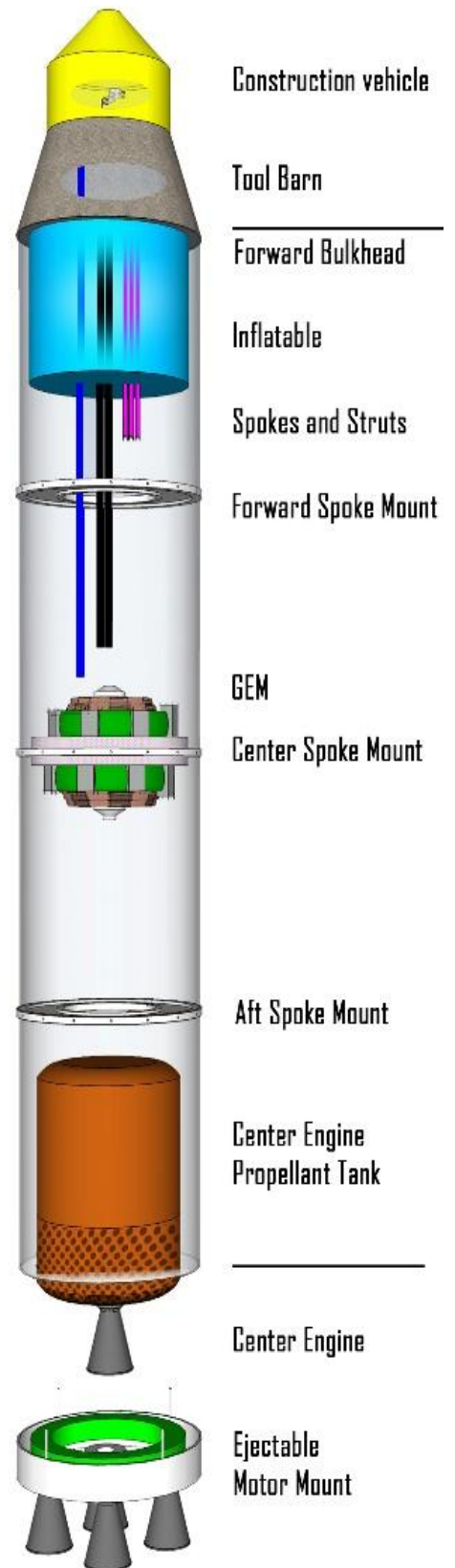
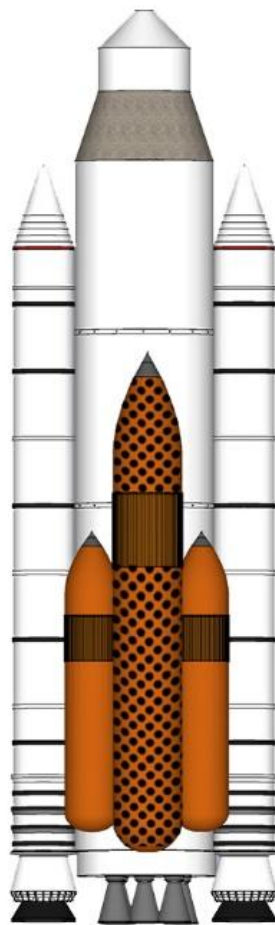

LIFE ON A STARCYCLER

Conceptual Illustration – Interior Environment

The vision of living in space has been a universal human aspiration.

StarCycler fulfills that vision by recreating an Earth-like environment while offering the unique experience of space habitation.



Residence and retail promenade



Corridor leading to the back retail promenade

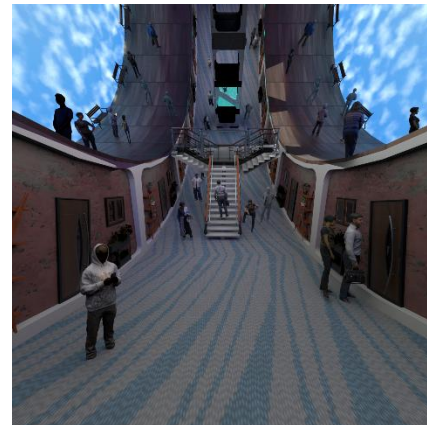

Residence interior walkway

Similar to a cruise liner, a full range of amenities is provided. Residential quarters are arranged along the outermost deck, encircling the station where artificial gravity is strongest. A central corridor separates the units, doubling as a continuous walking and jogging path. Elevator access connects all levels, including the zero-g core, while stairwells provide access to the inner promenade.

The promenade deck serves as the social center of the station, hosting shops, restaurants, and gathering spaces. Dual walking paths run along either side, with outer walls capable of displaying simulated day and night cycles. Natural sunlight may also be redirected into the structure, enhancing the sense of a living environment.

Above this level, the Skydeck incorporates a large, enclosed water system, supporting both environmental regulation and recreational use. Its reduced width reflects structural efficiency and mass distribution considerations.



Interior full View

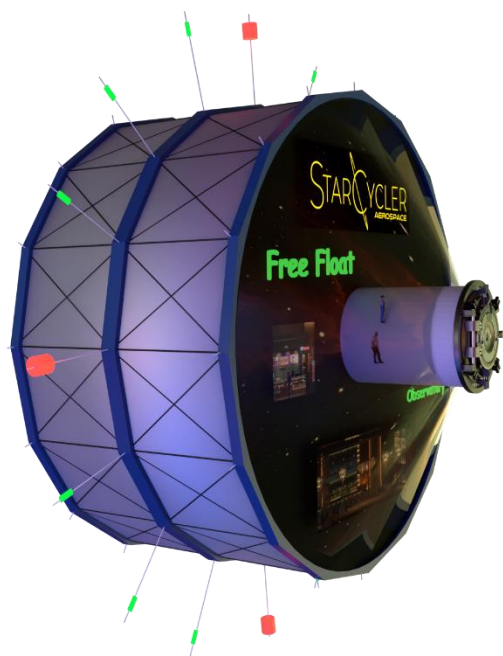

Bow Atrium

At the forward end, the bow atrium provides a free-floating observation space enclosed in transparent structural material, offering unobstructed views of the surrounding universe.

StarCycler supports a broad population, including scientists, technicians, tourists, and agricultural workers. Supporting vessels operating in proximity to the station provide functions such as food production, atmospheric processing, and industrial fabrication, forming an integrated orbital ecosystem.

Looking forward, StarCycler may serve as a hub within a broader transportation network, linking orbital platforms with lunar and planetary cycler routes, enabling staged transit between deep space, orbit, and planetary surfaces.