



**TRM-915-R25**  
**RF Transceiver Module**  
**Data Guide**

**Wireless made simple<sup>®</sup>**

**Warning:** Some customers may want Linx radio frequency (“RF”) products to control machinery or devices remotely, including machinery or devices that can cause death, bodily injuries, and/or property damage if improperly or inadvertently triggered, particularly in industrial settings or other applications implicating life-safety concerns (“Life and Property Safety Situations”).

**NO OEM LINX REMOTE CONTROL OR FUNCTION MODULE SHOULD EVER BE USED IN LIFE AND PROPERTY SAFETY SITUATIONS.** No OEM Linx Remote Control or Function Module should be modified for Life and Property Safety Situations. Such modification cannot provide sufficient safety and will void the product’s regulatory certification and warranty.

Customers may use our (non-Function) Modules, Antenna and Connectors as part of other systems in Life Safety Situations, but only with necessary and industry appropriate redundancies and in compliance with applicable safety standards, including without limitation, ANSI and NFPA standards. It is solely the responsibility of any Linx customer who uses one or more of these products to incorporate appropriate redundancies and safety standards for the Life and Property Safety Situation application.

**Do not use this or any Linx product to trigger an action directly from the data line or RSSI lines without a protocol or encoder/decoder to validate the data.** Without validation, any signal from another unrelated transmitter in the environment received by the module could inadvertently trigger the action.

**All RF products are susceptible to RF interference that can prevent communication.** RF products without frequency agility or hopping implemented are more subject to interference. This module does have a frequency hopping protocol built in, but the developer should still be aware of the risk of interference.

**Do not use any Linx product over the limits in this data guide.** Excessive voltage or extended operation at the maximum voltage could cause product failure. Exceeding the reflow temperature profile could cause product failure which is not immediately evident.

**Do not make any physical or electrical modifications to any Linx product.** This will void the warranty and regulatory and UL certifications and may cause product failure which is not immediately evident.

# Table of Contents

1	<a href="#">Introduction</a>
2	<a href="#">Ordering Information</a>
2	<a href="#">Absolute Maximum Ratings</a>
3	<a href="#">Electrical Specifications</a>
4	<a href="#">Pin Assignments</a>
5	<a href="#">Pin Descriptions</a>
6	<a href="#">Theory of Operation</a>
7	<a href="#">Module Description</a>
8	<a href="#">Module Operation</a>
10	<a href="#">Low-Power States</a>
12	<a href="#">Reset to Factory Default</a>
12	<a href="#">Compatibility Mode</a>
12	<a href="#">Exception Engine</a>
14	<a href="#">Networking Modes</a>
20	<a href="#">Voltage Supply Rise Time</a>
20	<a href="#">Using the Buffer Empty (BE) Line</a>
20	<a href="#">Using the Exception (EX) Line</a>
21	<a href="#">Receive Signal Strength Indication (RSSI)</a>
22	<a href="#">Using the RESET Line</a>
24	<a href="#">Using the Command Response (CMD_RSP) Line</a>
25	<a href="#">The CMD Line</a>
26	<a href="#">The UART Interface</a>
26	<a href="#">Configuration Command Formatting</a>
28	<a href="#">Module Configuration</a>
32	<a href="#">Writing to Registers</a>
32	<a href="#">Reading from Registers</a>
33	<a href="#">Configuration Registers</a>
56	<a href="#">Typical Applications</a>
56	<a href="#">Power Supply Requirements</a>

- 57 [Antenna Considerations](#)
- 57 [Helpful Application Notes from Linx](#)
- 58 [Interference Considerations](#)
- 59 [Microstrip Details](#)
- 60 [Pad Layout](#)
- 60 [Board Layout Guidelines](#)
- 62 [Production Guidelines](#)
- 62 [Hand Assembly](#)
- 62 [Automated Assembly](#)
- 64 [General Antenna Rules](#)
- 66 [Common Antenna Styles](#)
- 68 [Regulatory Considerations](#)
- 70 [Resources](#)
- 71 [Notes](#)

# TRM-915-R25 RF Transceiver Module Data Guide



## Description

The 25 Series RF transceiver module is designed for reliable bi-directional transfer of digital data over distances of up to 1 mile (1.6km) line of sight. Operating in the 902 to 928MHz frequency band, the module is capable of generating +13dBm into a 50-ohm load and achieves an outstanding typical sensitivity of -105dBm.

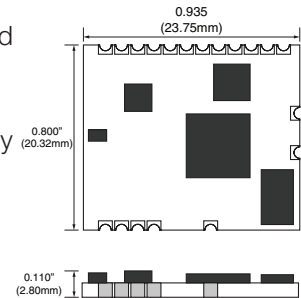

Figure 1: Package Dimensions

The module implements a Frequency Hopping Spread Spectrum (FHSS) protocol along with networking and assured delivery features. It has a Universal Asynchronous Receiver Transmitter (UART) serial interface that can be directly connected to microcontrollers, RS-232 converters or USB adaptors. The module automatically handles all radio functions resulting in a UART-to-antenna wireless link. All configuration settings and data are accessed through the UART interface.

## Features

- True UART to antenna solution
- Frequency Hopping (FHSS)
- 153.6kbps max RF data rate
- Includes robust protocol (CSMA, assured delivery, addressing)
- Low Power Standby, Sleep and Deep Sleep modes
- Adjustable output power
- 32-bit unique address
- 5 volt tolerant I/O

## Applications

- Direct RS-232/422/485 Wire replacement
- Asset tracking
- Automated meter reading
- Industrial/home automation
- Wireless sensors
- Remote data logging
- Fleet management
- Traffic and display signs
- Mass-transit communications
- Oil and gas sensing
- Long-range data links

## Ordering Information

Ordering Information		
Product Part No.	Description	Radiotrix Part No.
TRM-915-R25	Embedded Wireless Module, 25mW (900MHz)	Wi.232FHSS-25-R
EVM-915-025-FCx	Pinned, Pre-Certified Module, 25mW (900MHz)	Wi.232FHSS-25-FCC-xx-R

x = 'R' for right angle connector, 'S' for straight connector  
Transceivers are supplied in trays of 50 pieces

Figure 2: Ordering Information

## Absolute Maximum Ratings

Absolute Maximum Ratings				
Supply Voltage $V_{CC}$	0	to	3.9	VDC
Any Input or Output Pin	0	to	5.0	VDC
Supply Voltage Rise Time (GND to 2.7V)			1	ms
RF Input		10		dBm
Operating Temperature	-40	to	+85	°C
Storage Temperature	-40	to	+85	°C

Exceeding any of the limits of this section may lead to permanent damage to the device. Furthermore, extended operation at these maximum ratings may reduce the life of this device.

Figure 3: Absolute Maximum Ratings

 **Warning:** This product incorporates numerous static-sensitive components. Always wear an ESD wrist strap and observe proper ESD handling procedures when working with this device. Failure to observe this precaution may result in module damage or failure.

## Electrical Specifications

25 Series Transceiver Specifications						
Parameter	Symbol	Min.	Typ.	Max.	Units	Notes
Power Supply						
Operating Voltage	$V_{CC}$	3.0	3.3	3.6	VDC	
TX Supply Current	$I_{CCTX}$					1,2
@-2dBm			30		mA	
@+3dBm			35		mA	
@+8dBm			48		mA	
@+13dBm			65		mA	
RX Supply Current	$I_{CCRX}$		20		mA	1
Standby Current	$I_{STD}$		2.1		mA	1
Sleep Current	$I_{SLP}$		1.4		mA	1
Deep Sleep Current	$I_{DSLPL}$		3		µA	1
RF Section						
Operating Frequency Band	$F_C$	902.2		927.8	MHz	
Center Frequency Accuracy			2	4	PPM	3
Number of Channels			32		Chan.	
Channel Spacing			750		kHz	
Hop Sequences			6			4
Max Data Rate		115.2			kbps	
Antenna Port						
RF Impedance	$R_{IN}$		50		Ω	
Environmental						
Operating Temp. Range		-40		+85	°C	
Receiver Section						
Receiver Sensitivity						5
9.6kbps			-105		dBm	
38.4kbps			-102		dBm	
152.34kbps			-100		dBm	
Input IP3			-40		dBm	6
Adjacent Channel Rejection			-48		dBc	7
IF Bandwidth			600		kHz	
Transmitter Section						
Max Output Power	$P_O$		13	15	dBm	2
Harmonic Emissions	$P_H$		-50		dBc	2
Frequency Deviation	$F_{DEV}$		160		kHz	

## 25 Series Transceiver Specifications

Parameter	Symbol	Min.	Typ.	Max.	Units	Notes
Interface Section						
Input Logic Low	$V_{IL}$	0		0.8	VDC	
Input Logic High	$V_{IH}$	2.0		$V_{CC}$	VDC	
Output Logic Low	$V_{OL}$					
$I_{OL} = 8.5\text{mA}$				0.6	VDC	
$I_{OL} = 10\mu\text{A}$				0.1	VDC	
$I_{OL} = 25\text{mA}$			1.0		VDC	
Output Logic High	$V_{OH}$					
$I_{OH} = -3\text{mA}$		$V_{CC}-0.7$			VDC	
$I_{OH} = -10\mu\text{A}$		$V_{CC}-0.1$				
$I_{OH} = -10\text{mA}$			$V_{CC}-0.8$			
Flash Specifications (Non-Volatile Registers)						
Flash Write Duration			16		ms	
Flash Write Cycles		20k	100k		cycles	
1. $V_{CC} = 3.3\text{V}$			5. At $10^{-3}$ BER			
2. Into a 50-ohm load			6. $F_{LO} + 1\text{ MHz}$ & $F_{LO} + 1.945\text{ MHz}$			
3. At 25°C			7. $F_C \pm 650\text{ kHz}$			
4. 26 channels each						

Figure 4: Electrical Specifications

## Pin Assignments

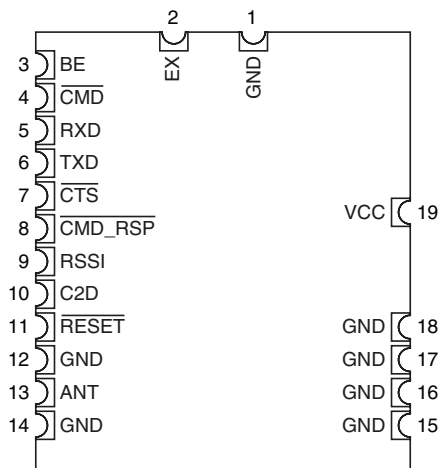

Figure 5: 25 Series Transceiver Pin Assignments (Top View)

## Pin Descriptions

Pin Descriptions			
Pin Number	Name	I/O	Description
1, 12, 14, 15, 16, 17, 18	GND	—	Ground
2	EX	O	Exception Output. A mask can be set to take this line high when an exception occurs. The line is lowered when the exception register is read (regEXCEPTION)
3	BE	O	Buffer Empty. This line goes high when the UART input buffer is empty, indicating that all data has been transmitted.
4	$\overline{\text{CMD}}$	I	Command Input. This line sets the serial data as either command data to configure the module or packet data to be sent over the air. Pull low for command data; pull high for packet data.
5	RXD	I	UART Receive Data Input. This is the input line for the configuration commands as well as data to be sent over the air.
6	TXD	O	UART Transmit Data Output. This is the output line for the configuration command responses as well as the data received over the air.
7	$\overline{\text{CTS}}$	O	UART Clear To Send, active low. This line indicates to the host microcontroller when the module is ready to accept data. When $\overline{\text{CTS}}$ is high, the module is busy. When $\overline{\text{CTS}}$ is low, the module is ready for data.
8	$\overline{\text{CMD\_RSP}}$	O	Command Response. This line is low when the data on the TXD line is a response to a command and not data received over the air.
9	RSSI	O	This line outputs an analog voltage that is proportional to the strength of the incoming signal.
10	C2D	—	Reserved
11	$\overline{\text{RESET}}$	I/O	Reset line. This line is normally an input that acts as an active low hardware reset line. It does occasionally act as an output, so please see the Reset section for details.
13	ANT	—	50-ohm RF Antenna Port
19	VCC	—	Supply Voltage

Figure 6: 25 Series Transceiver Pin Descriptions

## Theory of Operation

The 25 Series transceiver is a low-cost, high-performance synthesized FSK transceiver. Its wideband operation gives it outstanding range while still meeting regulatory requirements. Figure 7 shows a block diagram for the module.

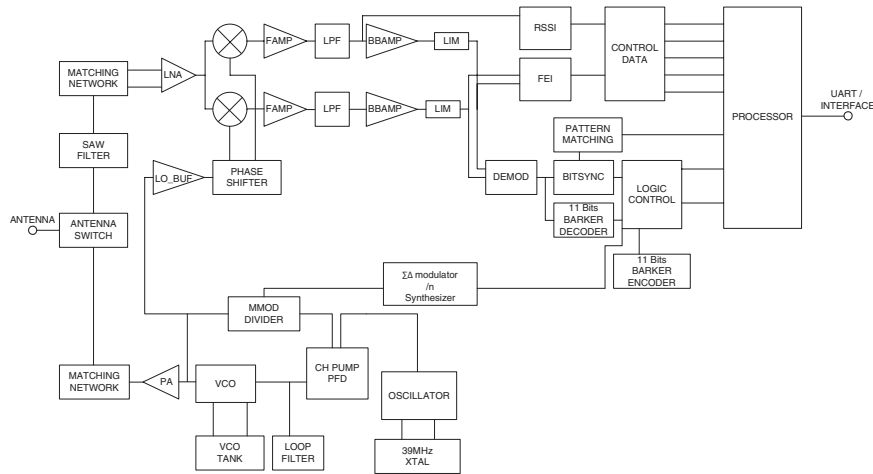

Figure 7: 25 Series Transceiver Block Diagram

The 25 Series transceiver is designed for operation in the 902 to 928MHz frequency band. The RF synthesizer contains a VCO and a low-noise fractional-N PLL. The receive and transmit synthesizers are integrated, enabling them to be automatically configured to achieve optimum phase noise, modulation quality and settling time.

The transmitter output power is programmable from  $-2\text{dBm}$  to  $+13\text{dBm}$ . The configurations are optimized to deliver the highest performance over a wide range of data rates.

The receiver incorporates highly efficient low-noise amplifiers that provide up to  $-105\text{dBm}$  sensitivity.

An onboard controller performs the radio control and management functions. A processor performs the higher level protocol functions and controls the serial and hardware interfaces.

## Module Description

The 25 Series RF transceiver module has a Universal Asynchronous Receiver Transmitter (UART) serial interface and is designed to create a complete UART-to-antenna wireless solution capable of direct wire replacement in most embedded RS-232/422/485 applications.

**Note:** Although the module is capable of supporting the serial data communications required by RS-232, RS-422, and RS-485 networks, it is not compatible with the electrical interfaces for these types of networks. The module has CMOS inputs and outputs and requires an appropriate converter for the particular type of network being used.

The module is designed to interface directly to a host UART. Three lines are used to transfer data between the module and the host UART: TXD, RXD, and  $\overline{\text{CTS}}$ . TXD is the data output from the module. RXD is the data input to the module. The  $\overline{\text{CTS}}$  output indicates if the module is ready to accept data. The UART interface is capable of operating in full duplex at baud rates from 2.4 to 115.2kbps.

The module has a built-in protocol that automatically transmits the data input on the UART. All encoding, transmitting, receiving and decoding functions are handled by the internal processor, so no overhead is required by an external processor. The networking modes in the protocol allow for point-to-point and broadcast transmissions as well as allowing for the creation of subnets and more complicated network topologies.

The module can be put into a Sleep mode through serial commands. In Sleep mode, the RF section is completely shut down and the protocol processor is in an idle state. Once the module has been placed in the sleep mode, it can be awakened by sending a power-up sequence through the serial port.

If the current draw in sleep mode is too high for a particular application, power to the module can be switched through an external FET to turn off the module when it is not needed. If this technique is used, the volatile registers are reset to the values in their non-volatile mirrors, so any changes from the default will have to be reloaded.

Every module has a 32-bit GUID address that can be used by the host application to uniquely identify each module. This address can be read through the serial interface.

## Module Operation

The module employs a Frequency Hopping Spread Spectrum (FHSS) algorithm. It has 32 channels spaced on 750kHz boundaries with a guard band on either side. These channels are pseudo-randomly arranged into six unique hopping tables comprised of 26 channels. The order of these tables is chosen so that cross-correlation is minimized, allowing multiple networks to operate in proximity with minimal interference.

When the module is not actively transmitting or receiving packets, it is in a scan state. It cycles through the channels in the hop sequence looking for a synchronizing packet. If it detects a preamble, it pauses to wait for the start code and packet header. If the packet is addressed to it, the module processes the packet and outputs the payload on the UART. If the packet is not addressed to the module or the start code and header fail their checks, the module resumes scanning for another packet.

When data is input on the RXD line for transmission, the module fills a buffer. Once the UART has buffered enough data to send (either regUARTMTU bytes input or regTXTO has expired between bytes on the RXD line), it transmits the data. The protocol engine makes a best-effort attempt to keep the data in at least regUARTMTU-sized packets, but splits the data based on the remaining dwell time before hopping. New data is not sent within the last 5% of the hop sequence, but data which is already in the process of being sent is processed normally.

The module prefixes the data with a packet header and postfixes the data with a 16-bit CRC. The 16-bit CRC error checking can be disabled to allow the host application to do its own error checking.

Initially, the transmission of the packet begins on a random hop index within the current hop sequence, and follows the hop sequence thereafter until synchronization is lost. The module uses a Carrier-Sense-Multiple-Access (CSMA) protocol to determine if another module is already transmitting on the selected channel. If the channel is occupied then the module waits for it to clear before transmitting its data.

Once the module gains access to the channel, if it is not already synchronized, it assigns itself master status, and sends a synchronizing preamble. Following a hop, the module that sends the first transmission assigns itself master status, sends a synchronizing preamble, and communications resume.

If acknowledgements are enabled for assured delivery, then once the packet is sent the module looks for an ACK from the other side. If the ACK is not received, a retry is performed and the transmission is sent again. If the number of transmission retries exceeds the value in the regMAXTXRETRY register, an exception (EX\_NORFACK) is raised.

Once the packet is sent, the transmitter deactivates but remains tuned to the current channel until its hop time expires. If another packet is queued for transmission, the module transmits this packet once the CSMA mechanism allows access to the channel. Once the hop timer expires, the module hops to the next channel.

Synchronization is lost whenever there is no more data to transfer and the module has detected two consecutive hop indices without data present. The module then returns to scan mode.

If another unit is transmitting when the module is ready to transmit a packet, the module receives that data before attempting to transmit its data. If the UART receive buffer gets full, the CTS line goes high to prevent the host UART from over-running the receive buffer.

The CSMA mechanism introduces a variable delay to the transmission if it detects that the channel is occupied. This delay is the sum of a random period and a weighted period that is dependent on the number of times that the module has tried and failed to access the channel. For applications that guarantee that only one module is transmitting at any given time, the CSMA mechanism can be turned off to avoid this delay.

## Low-Power States

The module supports three power saving modes: Standby, Sleep and Deep Sleep. Standby and Sleep are included primarily for legacy compatibility with DTS and EUR Series modules. The hardware required to support these two low-power modes fully is not present in the 25 Series modules. As a result, the current consumption in these two modes is considerably higher than their DTS / EUR counterparts. It is recommended that applications utilize the Deep Sleep mode for power savings.

In the Sleep and Deep Sleep modes, the transceiver is powered down and does not synchronize with other modules. Sleep mode draws more current than Deep Sleep mode. In Deep Sleep mode the module draws the least current. To wake the module up from this mode the  $\overline{\text{RESET}}$  line must be held low for at least 20 $\mu\text{s}$  and then taken high. The module does not monitor the receive channel in either mode. Therefore, a sleeping module cannot be woken through the RF interface.

If `regACKONWAKE` is enabled, the module transmits a 0x06 character on the TXD line once awakened from a low-power mode or power-off state. This indicates that the module is ready to resume operations.

Figure 8 indicates the line states while in a low-power mode.

25 Series Transceiver Low-Power Line States		
Line Name	Pin Number	Pin State
PR_PKT	1	Driven low
TXD	2	Input with weak pull-up
$\overline{\text{RESET}}$	6	Input with weak pull-up
C2D	7	Input with weak pull-up
$\overline{\text{CMD\_RSP}}$	9	Input with weak pull-up
EX	10	Driven low
RSSI	14	Driven low
$\overline{\text{CMD}}$	15	Input with weak pull-up
BE	16	Input with weak pull-up
$\overline{\text{CTS}}$	19	In Standby, Sleep: Driven Low, In Deep Sleep: Driven High
RXD	20	Input with weak pull-up

Figure 8: 25 Series Transceiver Low-Power Line States

## Standby

Standby is selected by writing a 0x02 to `regOPMODE`. In this mode, the internal oscillator of the module's protocol controller is lowered to its slowest setting. The transmitter and receiver hardware is in power-down, but the radio's oscillator is enabled and running. The module wakes from standby in less than 8ms. A low pulse on the RXD line wakes the module. This pulse should be at least 1 bit-time in duration, so sending any byte to the UART wakes it with the low start bit. Because the module's oscillator is not capable at running at ultra-low speeds, use of this mode is not recommended for new applications. The RAM contents are preserved during standby. If the RAM fails an integrity check, the module issues itself a software reset to force re-initialization.

## Sleep

Sleep is selected by writing a 0x01 to `regOPMODE`. The internal oscillator of the module's protocol controller is lowered to its slowest setting, and all radio services are stopped (receiver, transmitter, oscillator, etc.). The module wakes from sleep in less than 8ms. A low pulse on the RXD line wakes the module. This pulse should be at least 1 bit-time in duration, so sending any byte to the UART wakes it with the low start bit. Because the module's oscillator is not capable at running at ultra-low speeds, use of this mode is not recommended for new applications. The RAM contents are preserved during sleep. If the RAM fails an integrity check, the module issues itself a software reset to force re-initialization.

## Deep Sleep

Deep sleep is selected by writing a 0x03 to `regOPMODE`. When the module is put into deep sleep, the  $\overline{\text{CTS}}$  line is brought high to indicate that the module is not ready to accept UART data. The radio is placed in its lowest power mode and all services are stopped. The protocol controller's oscillator is also stopped and all non-essential functions are turned off. While powered, this mode consumes the least amount of current. The module wakes from deep sleep in less than 8ms. A low pulse of at least 20 $\mu\text{s}$  on the  $\overline{\text{RESET}}$  line starts the waking process, but the module doesn't begin executing wake instructions until the  $\overline{\text{RESET}}$  line is returned high. As with the other low-power modes, the RAM contents are preserved. If the RAM fails an integrity check, the module issues itself a software reset to force re-initialization. Note that, if the volatile data rate register is changed during the host application initialization (`regUARTDATARATE`), the re-initialization returns the module to the value in the non-volatile counterpart (`regNVUSERDATARATE`).

## Reset to Factory Default

It may be necessary to reset the non-volatile registers to their factory defaults. To reset the module, hold the  $\overline{\text{CMD}}$  line low and cycle power to hardware-reset the module. The  $\overline{\text{CMD}}$  line must remain low for a minimum of 600ms after resetting the module. Once the  $\overline{\text{CMD}}$  line is released, the module's non-volatile registers are reset to factory defaults.

## Compatibility Mode

The 25 Series modules support a mode that allows them to communicate with the higher power 250 Series modules. The 250 Series operates at a much narrower receive bandwidth (200kHz) than the 25 Series (600kHz). To allow interoperability, the 250 and 25 Series transceivers support a compatibility mode that allows the modules to communicate effectively with each other.

Compatibility mode reduces the maximum RF data rate to 76.8kbps. All UART baud rates are supported, although the RF data rates associated with baud rates 31,250; 38,400; 57,600 and 115,200 are reduced.

## Exception Engine

The modules are equipped with an internal exception engine. If errors occur during module operation, an exception is raised. Exception codes are stored in the *regEXCEPTION* register and are cleared once they are read. If an exception code is already present in *regEXCEPTION* when an error occurs, the new exception code overwrites the old value.

## Exception Codes

Exception codes are organized by type for ease of masking. Figure 9 lists the exception codes and their meanings. All other values are reserved.

25 Series Transceiver Exception Codes		
Exception Code	Exception Name	Description
0x08	EX_BUFOVFL	Internal UART buffers overflowed.
0x09	EX_RFOVFL	Internal RF packet buffer overflowed.
0x13	EX_WRITEREGFAILED	Attempted write to register failed.
0x20	EX_NORFACK	Acknowledgement packet not received after maximum number of retries.
0x40	EX_BADCRC	Bad CRC detected on incoming packet.
0x42	EX_BADHEADER	Bad CRC detected in packet header.
0x43	EX_BADSEQID	Sequence ID was incorrect in ACK packet.
0x44	EX_BADFRAMETYPE	Unsupported frame type specified.

Figure 9: 25 Series Transceiver Exception Codes

## Exception Masking

The EX line can be asserted to indicate to the host that an error has occurred. The exception mask provides a simple method of choosing which errors cause the line to toggle. If the result of ANDing the exception code with the exception mask is non-zero, the EX line is asserted. The *regEXCEPTION* register must be read to reset the line. Figure 10 lists some example exception masks.

25 Series Example Exception Masks	
Exception Mask	Exception Name
0x08	Allows only EX_BUFOVFL and EX_RFOVFL to trigger the EX line
0x10	Allows only EX_WRITEREGFAILED to trigger the EX line
0x20	Allows only EX_NORFACK to trigger the EX line
0x40	Allows only EX_BADCRC, EX_BADHEADER, EX_BADSEQID and EX_BADFRAMETYPE exceptions to trigger the EX line
0x60	Allows EX_BADCRC, EX_BADHEADER, EX_BADSEQID, EX_BADFRAMETYPE and EX_NORFACK exceptions to trigger the EX line
0xFF	Allows all exceptions to trigger the EX line

Figure 10: 25 Series Transceiver Example Exception Masks

The exception mask has no effect on the exceptions stored in the exception register. It only controls which exceptions affect the EX line.

## Networking Modes

The module has a very flexible addressing and networking scheme selected with the regNVNETWORKMODE and regNETWORKMODE registers. It can be changed during operation. The transmitting module addresses packets according to the network mode configuration. The receiving module processes all addressing types regardless of the network mode configuration. If the received message matches the addressing criteria, it is output on the UART. Otherwise it is discarded.

There are three networking modes: GUID, User and Extended User. Each mode offers different communications schemes, but all use source and destination addressing. The source address is for the transmitting unit, the destination address is the intended receiver. Each mode uses different registers for the source and destination addresses.

The module supports an automatic addressing mode that reads the Source Address from a received packet and uses it to fill the Destination Address register. This makes sure that a response is sent to the device that transmitted the original message. This also allows the host microcontroller to read out the address of the sending unit.

The automatic addressing is enabled for the different networking modes with register regAUTADD and regNVAUTADD.

## GUID Networking Mode

GUID networking mode is the simplest mode and supports point-to-point and broadcast communications. Each module is programmed at the factory with a unique 4-byte ID number that cannot be changed. These bytes are found in the non-volatile read only MYGUID registers (regMYGUID[0-3]). GUID networking mode uses these IDs as addresses. The transmitting unit's GUID is used as the source address and the intended receiver's GUID is written into the destination address register (regDESTGUID[0-3]). All modules within range hear the transmission, but only the module with the ID that matches the destination address outputs the data on its UART. All others ignore the transmission.

A broadcast message is created when the destination address is 0xFFFFFFFF. In this case, all modules within range output the data. It is not recommended to send broadcast messages when acknowledgements are enabled. Figure 11 lists some examples of how GUID networking works.

25 Series Transceiver GUID Network Mode Examples				
Sender Network Mode	Sender		Receiver	
	MyGUID	Destination GUID	MyGUID	Response
0x04 (GUID)	0x00001000	0xFFFFFFFF	0x00002000	Data output by both modules. No RF ACK sent by either module.
			0x00003000	
0x14 (GUID + ACK)	0x00001000	0xFFFFFFFF	0x00002000	Data output by both modules. No ACK sent by either module. This configuration causes transmission problems.
			0x00003000	
0x14 (GUID + ACK)	0x00001000	0x00003000	0x00002000	Not processed – discarded.
			0x00003000	Data output. RF ACK sent to 0x00001000
0x04 (GUID)	0x00001000	0x00002000	0x00002000	Data output. No RF ACK sent.
			0x00003000	Not processed – discarded.

Figure 11: 25 Series Transceiver GUID Network Mode Examples

## User Networking Mode

User Networking Mode is a more complicated scheme than GUID mode. It uses the customer ID bytes (regCUSTID[0-1]) and two of the user destination bytes (regUSERDESTID[0-1]) as a destination address. The customer ID bytes are programmed at the factory and cannot be changed. The module's local address is contained in two of the user source ID registers (regUSERSRCID[0-1]). Each module also has a user ID mask (regUSERIDMASK[0-1]) that provides an additional logical layer of addressing and can be used to create sub-networks. The receiving module masks its local address and the received destination address by calculating the logical AND with the user ID mask. If the results are equal, then the payload is output on the UART. The customer ID bytes are not masked, but must match the local value.

If acknowledgements are enabled, only the module with a user source ID that matches the transmitted user destination ID responds. The mask is not used for this determination.

If the result of the user ID Mask AND the received user destination address equals the same value as the user ID mask, then the payload data is output on the UART. This acts as a broadcast message to the network.

Setting the mask to 0xFFFF removes the mask and only the source and destination addresses are used for networking. When using user network mode to send packets to multiple users and the mask is not equal to 0xFFFF, acknowledgements must be disabled. Failure to do so could cause extreme delays in transmission and loss of data.

As an example, if the mask is 0xFFFF0 and the destination address transmitted by the sender is 1234, then all modules with a source ID of 123x respond. This gives a subnet of 16 modules (where x = 0 to F) and acts as a broadcast message to the sub-net. Acknowledgements should be disabled.

Figure 14 shows this example and Figure 12 and Figure 13 show some more examples of user networking mode.

25 Series Transceiver User Network Mode Examples					
Destination ID from Received Packet	Receiver Source ID	Receiver User ID Mask	Result of Dest AND Mask	Result of Source AND Mask	Action
3000	2000	E000	2000	2000	The results are equal, so the payload is output on the UART.
	3000			2000	The results are equal, so the payload is output on the UART. The destination ID and the source ID match, so an ACK is transmitted if enabled.
	4000			4000	The results do not match, so the packet is discarded.
3000	2000	F000	3000	2000	The results do not match, so the packet is discarded.
	3000			3000	The results are equal, so the payload is output on the UART. The destination ID and the source ID match, so an ACK is transmitted if enabled.
	4000			4000	The results do not match, so the packet is discarded.
E000	2000	E000	E000	2000	The destination ID matches the user ID mask, so the data is output on the UART.
	3000			2000	
	4000			4000	

Figure 12: 25 Series Transceiver User Network Mode Examples

25 Series Transceiver User Network Mode Examples					
Sender Network Mode	User SRCID	User DESTID	User SRCID	User IDMASK	Response
0x06 (User)	0x1000	0xFFFF	0x2000	0xFFFF	Data output by both modules. No ACK sent by either module.
			0x3000	0xFFFF	
0x16 (User + ACK)	0x1000	0xFFFF	0x2000	0xFFFF	Data output by both modules. No ACK sent by either module. This configuration causes transmission problems.
			0x3000	0xFFFF	
0x16 (User + ACK)	0x1000	0x3000	0x2000	0xE000	Data output. No ACK sent.
			0x3000	0xE000	Data output. ACK sent to 0x1000.
0x6 (User)	0x1000	0x3000	0x2000	0xF000	Not processed – discarded.
			0x3000	0xF000	Data output. No ACK sent.

Figure 13: 25 Series Transceiver User Network Mode Examples

25 Series Transceiver User Network Mode Examples					
Destination ID from Received Packet	Receiver Source ID	Receiver User ID Mask	Result of Dest AND Mask	Result of Source AND Mask	Action
1234	Any module with 123x	FFF0	1230	1230	The results are equal, so the payload is output on the UART. <b>Do not enable acknowledgements</b>

Figure 14: 25 Series Transceiver User Network Mode Examples

### Extended User Addressing Mode

Extended User Networking Mode is the same as User Networking Mode but uses longer addresses. The two customer ID bytes are still used (regCUSTID[0-1]) but all four bytes are used for the user destination address (regUSERDESTID[0-3]), user source ID (regUSERSRCID[0-3]) and user ID mask (regUSERIDMASK[0-3]). This provides more addressing capabilities at the expense of more overhead in the packet. Otherwise all functionality is the same.

25 Series Transceiver Extended User Network Mode Examples					
Sender			Receiver		Response
Network Mode	User SRCID	User DESTID	User SRCID	User IDMASK	
0x07	0x10000000	0xFFFFFFFF	0x20000001	0xFFFFFFFF	Data output by both modules. No ACK sent by either module.
			0x20000002	0xFFFFFFFF	
0x17	0x10000000	0xFFFFFFFF	0x20000001	0xFFFFFFFF	Data output by both modules. No ACK sent by either module. This configuration will cause transmission problems.
			0x20000002	0xFFFFFFFF	
0x17	0x10000000	0x30000001	0x20000001	0xE0000000	Data output. No ACK sent.
			0x30000001	0xE0000000	Data output. ACK sent to 0x1000.
0x07	0x10000000	0x30000002	0x20000001	0xF0000000	Not processed – discarded.
			0x30000001	0xF0000000	Data output. No ACK sent.

Figure 15: 25 Series Transceiver Extended User Network Mode Examples

### Assured Delivery (Acknowledgement)

While not an addressing mode on its own, assured delivery can be enabled for each of the addressing modes. When a module transmits with assured delivery enabled, it obligates the receiving module to return an acknowledgement packet. The transmitting module waits for this acknowledgement for a preset amount of time based on the data rate. If an acknowledgement is not received, it retransmits the packet. If the receiver receives more than one of the same packet, it discards the packet contents but sends an acknowledgment. This way, duplicate data is not output by the module. It is extremely important that assured delivery be used only when the unmasked user/extended user Destination ID or Destination GUID points to a specific module. Failure to specifically address a valid module could cause the module to appear slow or unresponsive due to repeated retransmissions. This also serves to congest the network, impeding valid communications.

If the received destination address matches the local address, the receiving module immediately sends an RF ACK packet. This packet lets the sending module know that the message has been received. An RF ACK packet is sent immediately following reception; CSMA delay is not applied to RF ACK packets. When the sending module receives the RF ACK packet, it marks the current block of data as completed. If this is the last message in the queue, the sending module asserts the BE line to indicate the state of the incoming buffer.

**Troubleshooting Hint:** If modules are unable to communicate with each other, check the following:

- Check to make sure that both modules are set to the same data rate. Modules programmed with different data rates will not communicate or share an RF channel with one another.
- Ensure that the network mode and addressing is configured to properly access the module of interest. Also, ensure that a specific module is addressed when using acknowledgment. Failure to do so causes large delays and loss of data.

## Voltage Supply Rise Time

The power supply rise time is extremely important. It must rise from ground to 2.7V in less than 1ms. If this specification cannot be met, an external reset supervisor circuit must be used to hold the module in reset until the power supply stabilizes. Failure to ensure adequate power supply rise time can result in loss of important module configuration information.

## Using the Buffer Empty (BE) Line

The BE line indicates the state of the module's UART buffer. When the module receives data in the RXD line and the CMD line is high, the BE line is lowered until all data in the buffer has been processed by the protocol engine. If acknowledgement is not enabled, the BE line is raised as soon as the protocol engine processes the outgoing packets. If acknowledgement is enabled, the buffer is not updated until either the data transmissions are acknowledged by the remote end or delivery fails after the maximum number of retries. When the BE line returns high, the EX line may be sampled, or the regEXCEPTION register polled to determine if an error occurred during transmission.

## Using the Exception (EX) Line

The EX line indicates whether or not a module exception has occurred. The line is normally low, but it is raised if an exception occurs that passes masking. When the regEXCEPTION register is read, the exception is cleared and the EX line returns low. If more than one exception occurs before the regEXCEPTION register is read, the old exception is overwritten by the new one. Please see the Exception Engine section for more details.

## Receive Signal Strength Indication (RSSI)

The RSSI line outputs an analog voltage that is proportional to the signal strength present on the channel at the time. In normal operation, the module is hopping rapidly from channel to channel. In this case, the RSSI value varies greatly and does not provide much useful information. However, it can be used to keep a module awake by sampling the RSSI line to determine if the module is processing a packet before putting it to sleep.

The 25 Series module has an internal digital RSSI indication of the immediate ambient environment and of the last good packet received.

RSSI level is dependent on the power of the signal received at the antenna port and the mode the LNA is in. regLNAMODE controls the mode of the internal LNA. Figure 16 shows typical traces of RSSI voltage versus signal strength.

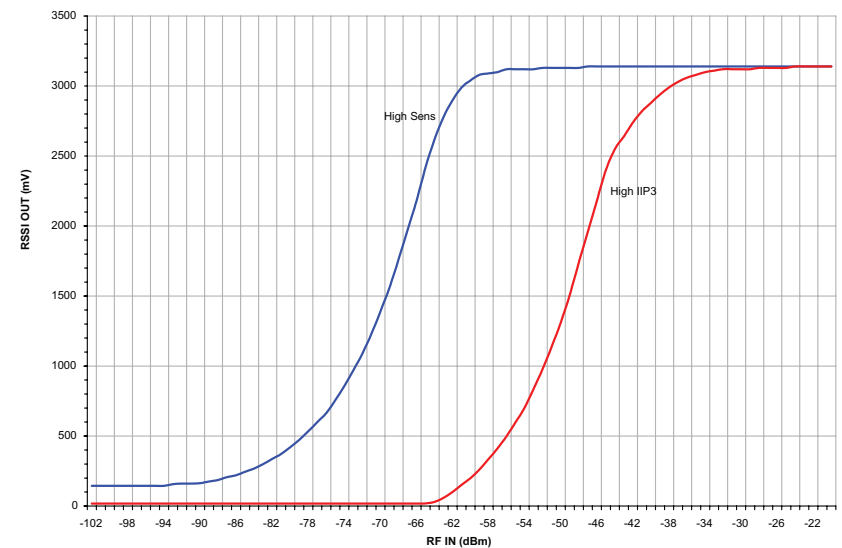

Figure 16: 25 Series Transceiver P<sub>IN</sub> vs RSSI Voltage

## Using the $\overline{\text{RESET}}$ Line

The  $\overline{\text{RESET}}$  line has different functions depending on the state the module is in. It is an open-drain input/output line with an integrated weak pull-up, so it is normally high. Because it periodically operates as an output, external control should only pull this line low, not high.

### Hardware Reset (Input)

During normal operation, the  $\overline{\text{RESET}}$  line functions as an active-low hardware reset input. Taking this line low for at least  $15\mu\text{s}$  forces the module's controller into hardware reset. While the line is low, execution of module operations are suspended and all module lines revert to open-drain inputs with weak pull-ups. This behavior can be exploited during power-up if the  $V_{\text{CC}}$  ramp time exceeds 1ms. By suspending execution, the dangers associated with slow  $V_{\text{CC}}$  ramp are eliminated.

### Wake from Deep Sleep (Input)

When the module is in deep sleep, all execution is suspended in the controller and the radio is in its lowest power mode. The  $\overline{\text{RESET}}$  line must be lowered for at least  $15\mu\text{s}$  to wake the module. When the  $\overline{\text{RESET}}$  line is raised, execution begins in the controller. The module maintains its state engine while asleep. Because of this, it can detect whether the hardware reset was intended to cause a hard reset or wake the module. The controller's RAM is preserved during deep sleep. The RAM is checked prior to entering deep sleep, and examined upon waking. If the RAM contents are corrupted upon wake, the module issues itself a software reset to reinitialize the module.

### Hardware Reset Indicator (Output)

When the module starts from power-off, or is reset by the internal  $V_{\text{CC}}$  monitor circuitry, the  $\overline{\text{RESET}}$  line is driven low to indicate the reset state. During power-on reset, assuming the  $V_{\text{CC}}$  ramp time is valid,  $\overline{\text{RESET}}$  is driven low from the time that  $V_{\text{CC}}$  reaches approximately 1V until  $V_{\text{CC}}$  reaches  $V_{\text{RST}} + T_{\text{PORDelay}} \cdot T_{\text{PORDelay}}$  is the power-on reset delay imposed by the controller's hardware.

The other event that drives the  $\overline{\text{RESET}}$  line low is a low-voltage or brown-out condition. In this case, the  $V_{\text{CC}}$  monitor holds the module in reset, thus driving the  $\overline{\text{RESET}}$  line low. It remains low until the power drops below the operating threshold for that circuit (becoming indeterminate), or until the module's power supply returns to  $V_{\text{RST}}$ . Figure 17 illustrates the operation of  $\overline{\text{RESET}}$  as an output.

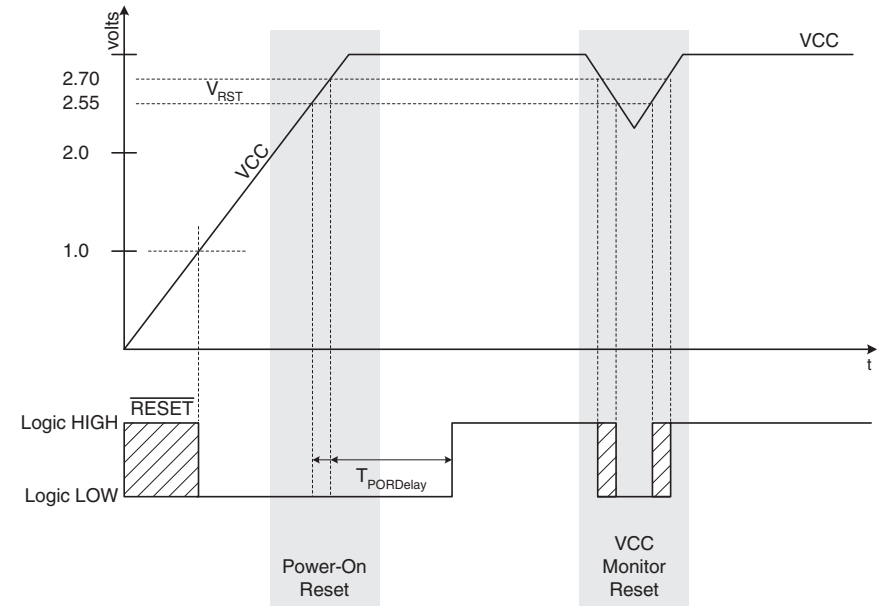

Figure 17: 25 Series Transceiver Reset Timing Diagram

### 25 Series Transceiver Reset Circuit Specifications

Parameter	Min.	Typ.	Max.	Units	Notes
$\overline{\text{RESET}}$ Output Low Voltage			0.6	V	$V_{\text{CC}} = 2.7 - 3.6\text{V}$
$\overline{\text{RESET}}$ Input Pull-up Current		25	40	$\mu\text{A}$	$\overline{\text{RESET}} = 0.0\text{V}$
$V_{\text{CC}}$ Monitor Threshold ( $V_{\text{RST}}$ )	2.40	2.55	2.70	V	
Minimum $\overline{\text{RESET}}$ Low Time to Generate a Hardware Reset	15			$\mu\text{s}$	
Power-on Reset Delay ( $T_{\text{PORDelay}}$ )		<300		$\mu\text{s}$	$V_{\text{CC}}$ Ramp Time is Valid
Allowed/Valid $V_{\text{CC}}$ Ramp Time			1	ms	

Figure 18: 25 Series Transceiver Reset Circuit Specifications

**Warning:** If the  $\overline{\text{RESET}}$  line experiences noise, it can cause multiple triggers (wake from sleep, hardware reset, hardware reset, etc.) and cause the volatile registers to be reloaded with their non-volatile values. If the circuit introduces noise onto this line, a bypass capacitor or RC filter should be placed on the line as close to the module as is practical.

## Using the Command Response ( $\overline{\text{CMD\_RSP}}$ ) Line

The  $\overline{\text{CMD\_RSP}}$  line is normally high, but the module lowers this line when it responds to a UART command. This indicates to an external processor that the data on the TXD line is a response to a command and not data received over-the-air.

The module outputs received RF data immediately following the command response. The  $\overline{\text{CMD\_RSP}}$  line does rise before resuming RF data, but some processors cannot react quickly enough to this signal and may not be able to separate the command responses from RF data.

The regCMDHALT register controls the behavior of the TXD line when the  $\overline{\text{CMD}}$  line is low and the external processor is configuring the module. If this register is set to 0x01 and the  $\overline{\text{CMD}}$  line is low, the module stops outputting the RF data and internally buffers it. Once the  $\overline{\text{CMD}}$  line is raised, the buffered RF data is output on the TXD line. This allows the external processor to have separate configuration times and data times instead of potentially having to handle both at once.

## The $\overline{\text{CMD}}$ Line

The  $\overline{\text{CMD}}$  line is used to inform the module where incoming UART data should be routed. When the line is high or left floating, all incoming UART data is treated as payload data and is routed to the transmitter to be sent over the air. If the  $\overline{\text{CMD}}$  line is low, the incoming UART data is routed to the command parser for processing. Since the module's controller looks at UART data one byte at a time, the  $\overline{\text{CMD}}$  line must be held low for the entire duration of the command plus a 20 $\mu\text{s}$  margin for processing. Leaving the line low for additional time (for example, until the ACK byte is received by the application) does not adversely affect the module. If RF packets are received while the  $\overline{\text{CMD}}$  line is active, they are still processed and output on the module's UART. Figure 19 shows this timing.

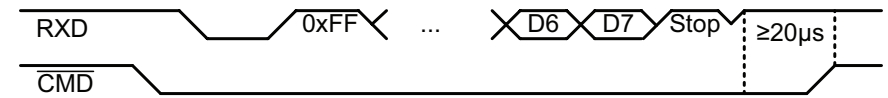

Figure 19: 25 Series Transceiver  $\overline{\text{CMD}}$  Line Timing

The  $\overline{\text{CMD}}$  line is also used during the module startup process to determine whether or not to reload the non-volatile registers with factory defaults. The module startup process is executed when the module is powered on from an off state or is issued a software or hardware reset. When the module goes through this startup process, it checks the state of the  $\overline{\text{CMD}}$  line. If it is low, the module clears the non-volatile registers and re-populates them with factory default values. It is important to ensure that  $\overline{\text{CMD}}$  is held high or left floating during power-up under normal conditions.

Possible reset sources that could cause the module to reboot are power supply brown-out, power supply instability and noise present on the  $\overline{\text{RESET}}$  line, noise/voltage spikes on digital I/O lines, issuing a reset command through the command interface, and toggling the  $\overline{\text{RESET}}$  line when not in deep sleep.

## The UART Interface

The module uses a standard UART interface for both data to be sent over the air and for configuring the module. The  $\overline{\text{CMD}}$  line is used to tell the module if the data on the UART is for configuration or transmission. The lines follow the standard UART naming convention, so RXD is the data input into the module and TXD is the data output from the module. The UART interface expects 1 start bit, 8 data bits (LSB first), and 1 stop bit per byte with no parity (8-N-1).

The module has a 256 byte buffer for incoming data. The module can be programmed to automatically transmit when the buffer reaches a limit or based on the time between bytes on the UART. This allows the designer to optimize the module for fixed length and variable length data. The module supports streaming data as well. To optimize the module for streaming data, regUARTMTU should be set to 128, and regTXTO should be set to a value greater than 1 UART byte time at the current UART data rate (10 bit times rounded up) or 2, whichever is greater.

If the buffer gets nearly full (about 224 bytes), the module pulls the  $\overline{\text{CTS}}$  line high, indicating that the host should not send any more data. Data sent by the host while the buffer is full is lost, so the  $\overline{\text{CTS}}$  line provides a warning and should be monitored. When there is data in the UART receive buffer, the BE line is low; when this buffer is empty, BE is high.

## Configuration Command Formatting

The 25 Series module contains several volatile and non-volatile registers that control its configuration and operation. The volatile registers all have non-volatile mirror registers that are used to determine the default configuration when power is applied to the module. During normal operation, the volatile registers are used to control the module.

Placing the module in the command mode allows these registers to be programmed. Byte values in excess of 127 (0x80 or greater) must be changed into a two-byte escape sequence of the format:

0xFE, [value - 128]

For example, the value 0x83 becomes 0xFE, 0x03. The function in Figure 20 prepends a 0xFF header and size specifier to a command sequence and creates escape sequences as needed. It is assumed that \*src is populated with either the register number to read (one byte, pass 1 into

src\_len) or the register number and value to write (two bytes, pass 2 into src\_len). It is also assumed that the \*dest buffer has enough space for the two header characters plus the encoded command and the null terminator.

```
int EscapeString(char *src, char src_len, char *dest)
{
    // The following function copies and encodes the first
    // src_len characters from *src into *dest. This
    // encoding is necessary for module command formats.
    // The resulting string is null terminated. The size
    // of this string is the function return value.
    // -----
    char src_idx, dest_idx;
    // Save space for the command header and size bytes
    // -----
    dest_idx = 2;
    // Loop through source string and copy/encode
    // -----
    for (src_idx = 0; src_idx < src_len; src_idx++)
    {
        if (src[src_idx] > 127)
        {
            dest[dest_idx++] = 0xFE;
        }/*if*/
        dest[dest_idx++] = (src[src_idx] & 0x7F);
    }/*for*/
    // Add null terminator
    // -----
    dest[dest_idx] = 0;
    // Add command header
    // -----
    dest[0] = 0xFF;
    dest[1] = dest_idx - 2;
    // Return escape string size
    // -----
    return dest_idx;
}
```

Figure 20: Command Conversion Code

## Module Configuration

The 25 Series module contains several registers that control its configuration and operation. The module's default settings allow it to operate out of the box without any changes; however the registers allow the link to be customized to better suit the application if necessary. The register settings are stored in two types of memory inside the module. Volatile memory is quick to access, but it is lost when power is removed from the module. Non-volatile memory takes longer to access, but is retained when power is removed.

All of the configuration settings have registers in both types of memory. The settings are read from non-volatile registers on power up and saved in volatile registers. The values in the volatile registers are used during normal operation since it is faster to read and write the volatile memory locations. There are commands to read and write both locations.

Figure 21 shows the volatile read-only registers. Figure 22 shows the volatile read and write registers. Figure 23 shows the non-volatile read-only registers. Figure 24 shows the non-volatile read and write registers.

25 Series Volatile Read-Only Configuration Registers		
Name	Address	Description
regEXCEPTION	0x79	Stores latest exception code
regLGPRSSI	0x7B	Last Good Packet RSSI value
regIMMEDRSSI	0x7C	Current RSSI value

Figure 21: 25 Series Volatile Read Only Configuration Registers

25 Series Volatile Read / Write Configuration Registers		
Name	Address	Description
regCRCERRCOUNT	0x40	CRC error count value
regHOPTABLE	0x4B	Hop table
regPWRMODE	0x4D	Power amplifier setting
regUARTDatarate	0x4E	UART data rate
regNETWORKMODE	0x4F	Sets the networking mode
regTXTO	0x50	UART to transmit timeout
regMAXTXRETRY	0x52	Maximum times to retry packet transmission
regUSECRC	0x53	Enable / Disable CRC checking
regUARTMTU	0x54	Minimum transmission unit
regCSMAMODE	0x56	Enable / Disable CSMA

25 Series Volatile Read / Write Configuration Registers Continued		
Name	Address	Description
regOPMODE	0x58	Sets operating mode
regACKONWAKE	0x59	Enable / Disable ACK sent to UART upon wake
regUSERDESTID[3]	0x5A	Destination Address for Extended User Networking Mode
regUSERDESTID[2]	0x5B	Destination Address for Extended User Networking Mode
regUSERDESTID[1]	0x5C	Destination Address for User and Extended User Networking Mode
regUSERDESTID[0]	0x5D	Destination Address for User and Extended User Networking Mode
regUSERSRCID[3]	0x5E	Source Address for Extended User Networking Mode
regUSERSRCID[2]	0x5F	Source Address for Extended User Networking Mode
regUSERSRCID[1]	0x60	Source Address for User and Extended User Networking Mode
regUSERSRCID[0]	0x61	Source Address for User and Extended User Networking Mode
regUSERIDMASK[3]	0x62	Address Mask for Extended User Networking Mode
regUSERIDMASK[2]	0x63	Address Mask for Extended User Networking Mode
regUSERIDMASK[1]	0x64	Address Mask for User and Extended User Networking Mode
regUSERIDMASK[0]	0x65	Address Mask for User and Extended User Networking Mode
regDESTGUID[3]	0x68	GUID Networking Mode Destination Address
regDESTGUID[2]	0x69	GUID Networking Mode Destination Address
regDESTGUID[1]	0x6A	GUID Networking Mode Destination Address
regDESTGUID[0]	0x6B	GUID Networking Mode Destination Address
regEXCEPTIONMASK	0x6C	Exception and Mask used to activate the EX line
regCMDHALT	0x6E	Half RF traffic when the $\overline{\text{CMD}}$ line is low
regLNAMODE	0x6F	Receiver LNA gain / linearity setting
regCOMPATMODE	0x70	Compatibility mode for 25 and 250 intercommunication
regAUTADD	0x71	Sets automatic addressing

Figure 22: 25 Series Volatile Read / Write Configuration Registers

**Warning:** Modules that are not configured in the same way will not be able to communicate reliably, causing poor performance or outright failure of the wireless link. All modules in a network must have compatible configurations to ensure interoperability.

25 Series Non-Volatile Read-Only Registers			
Name	Address	Description	
regMyGUID[3]	0x34	Factory programmed GUID used in GUID Networking Mode	
regMYGUID[2]	0x35	Factory programmed GUID used in GUID Networking Mode	
regMYGUID[1]	0x36	Factory programmed GUID used in GUID Networking Mode	
regMYGUID[0]	0x37	Factory programmed GUID used in GUID Networking Mode	
regCUSTID[1]	0x39	Factory programmed customer ID, default 0xFF	
regCUSTID[0]	0x3A	Factory programmed customer ID, default 0xFF	
regRELEASENUM	0x78	Holds release number indicating h/w and f/w	

Figure 23: 25 Series Non-volatile Read Only Configuration Registers

25 Series Non-Volatile Read / Write Registers			
Name	Address	Description	Factory Default
regNVHOPTABLE	0x00	Hop table	0
regNVPWRMODE	0x02	Power amplifier setting	3 (High Power)
regNVUARTDatarate	0x03	UART data rate	0 (2400)
regNVNETWORKMODE	0x04	Sets the networking mode	4 (MAC/GUID)
regNVTXTTO	0x05	UART to transmitter timeout	16 (15–16ms)
regNVMAXTXRETRY	0x07	Maximum times to retry packet transmission	26
regNVUSECRC	0x08	Enable/Disable CRC checking	1 (Enable)
regNVUARTMTU	0x09	Minimum transmission unit	64 (64 bytes)
regNVSHOWVERSION	0x0A	Enable/disable startup message	1 (Enabled)
regNVCSMAMODE	0x0B	Enable/Disable CSMA	1 (Enable)
regNVOPMODE	0x0D	Sets operating mode	0 (Awake)
regNVACKONWAKE	0x0E	Enable/Disable ACK sent to UART upon wake from	1 (Enable)
regNVUSERDESTID[3]	0x0F	Destination Address for Extended User Networking Mode	0xFF
regNVUSERDESTID[2]	0x10	Destination Address for Extended User Networking Mode	0xFF
regNVUSERDESTID[1]	0x11	Destination Address for User and Extended User Networking Mode	0xFF

25 Series Non-Volatile Read / Write Registers Continued			
Name	Address	Description	Factory Default
regNVUSERDESTID[0]	0x12	Destination Address for User and Extended User Networking Mode	0xFF
regNVUSERSRCID[3]	0x13	Source Address for Extended User Networking Mode	0xFF
regNVUSERSRCID[2]	0x14	Source Address for Extended User Networking Mode	0xFF
regNVUSERSRCID[1]	0x15	Source Address for User and Extended User Networking Mode	0xFF
regNVUSERSRCID[0]	0x16	Source Address for User and Extended User Networking Mode	0xFF
regNVUSERIDMASK[3]	0x17	Address Mask for Extended User Networking Mode	0xFF
regNVUSERIDMASK[2]	0x18	Address Mask for Extended User Networking Mode	0xFF
regNVUSERIDMASK[1]	0x19	Address Mask for User and Extended User Networking Mode	0xFF
regNVUSERIDMASK[0]	0x1A	Address Mask for User and Extended User Networking Mode	0xFF
regNVDESTGUID[3]	0x1D	GUID Networking Mode Destination Address	0xFF
regNVDESTGUID[2]	0x1E	GUID Networking Mode Destination Address	0xFF
regNVDESTGUID[1]	0x1F	GUID Networking Mode Destination Address	0xFF
regNVDESTGUID[0]	0x20	GUID Networking Mode Destination Address	0xFF
regNVEXCEPTIONMASK	0x21	Used to mask exception for the EX line	0xFF (All)
regNVCMDHALT	0x23	Halt RF traffic when the $\overline{\text{CMD}}$ line is low	0 (Disabled)
regNVLNAMODE	0x24	Receiver LNA gain / linearity setting	0 (Auto)
regNVCOMPATMODE	0x25	Compatibility mode for 25 and 250 intercommunication	0 (Disabled)
regNVAUTADD	0x26	Sets automatic addressing	0 (Disabled)

Figure 24: 25 Series Non-volatile Read / Write Configuration Registers

## Writing to Registers

Writing to a volatile register is nearly instantaneous. Writing to a non-volatile register typically takes 16ms. Because the packet size can vary based on the need for encoding, there are two possible packet structures. The first structure writes a value that is less than 128 (0x80) and the second writes a value that is higher. The higher value must be split into two values. Figure 25 shows the byte sequences for writing a register in each case.

25 Series Write to Configuration Register Command				
<b>Command for a Value less than 128 (0x80)</b>				
Header	Size	Address	Value	
0xFF	0x02	REG	V1	
<b>Command for a Value greater than 128 (0x80)</b>				
Header	Size	Address	Value 1	Value 2
0xFF	0x03	REG	0xFE	V2

Figure 25: 25 Series Write to Configuration Register Command

The module responds with an ACK (0x06). If it is not received, the command should be resent. The module responds with a NACK (0x15) if a write is attempted to a read-only or invalid register.

**Warning:** The module must remain powered for the duration of the register write or important configuration information could be lost.

## Reading from Registers

A register read command is constructed by placing an escape character (0xFE) before the register number. The module responds by sending an ACK (0x06) followed by the register number and register value. The register value is sent unmodified, so if the register value is 0x83, 0x83 is returned. If the register number is invalid, the module responds with a NACK (0x15). The command and response are shown in Figure 26.

25 Series Read From Configuration Register			
<b>Command</b>			
Header	Size	Escape	Address
0xFF	0x02	0xFE	REG
<b>Response</b>			
ACK	Address	Value	
0x06	REG	V1	

Figure 26: 25 Series Read from Configuration Register Command and Response

## Configuration Registers

The following sections give details on each configuration register. Green addresses in the tables are volatile locations and blue are non-volatile.

### CRC Error Count - Address = 0x40

The value in the regCRCERRCOUNT register is incremented each time a packet is received that fails CRC check. Writing 0x00 to this register initializes the count. Figure 27 shows the command and response.

25 Series CRC Error Count						
<b>Read Command</b>				<b>Read Response</b>		
Header	Size	Escape	Address	ACK	Address	Value
0xFF	0x02	0xFE	0x40	0x06	0x40	V1
<b>Write Command</b>						
Header	Size	Address	Value			
0xFF	0x02	0x40	V1			

Figure 27: 25 Series CRC Error Count Command and Response

### Channel Hop Table - Address = 0x4B; NV Address = 0x00

The module supports 6 different hop sequences with minimal correlation. The sequence is set by the value in the regHOPTABLE register. Changing the hop sequence changes the physical band utilization, much the same way that a channel does in a static transmitter. Valid values are 0–5. Figure 28 shows the command and response.

25 Series Channel Hop Table						
<b>Read Command</b>				<b>Read Response</b>		
Header	Size	Escape	Address	ACK	Address	Value
0xFF	0x02	0xFE	0x4B 0x00	0x06	0x4B 0x00	V1
<b>Write Command</b>						
Header	Size	Address	Value			
0xFF	0x02	0x4B 0x00	V1			

Figure 28: 25 Series Channel Hop Table Command and Response

Figure 29 shows the RF channels used by the 25 Series and the hop sequences referenced by channel number. The default hop sequence is 0.

25 Series RF Channels and Hop Sequences							
Channel Number	Frequency (MHz)	Hop Sequence by Channel Number					
		0	1	2	3	4	5
0	902.971	16	15	3	28	22	9
1	903.723	1	30	20	11	7	24
2	904.475	2	29	21	10	8	23
3	905.226	5	26	24	7	11	20
4	905.978	10	21	29	2	16	15
5	906.730	21	10	8	23	27	4
6	907.482	11	20	30	1	17	14
7	908.234	23	8	10	21	29	2
8	908.986	14	17	1	30	20	11
9	909.737	29	2	16	15	3	28
10	910.489	27	4	14	17	1	30
11	911.241	22	9	9	22	28	3
12	911.993	12	19	31	0	18	13
13	912.745	24	7	11	20	30	1
14	913.496	17	14	4	27	23	8
15	914.248	3	28	22	9	9	22
16	915.000	7	24	26	5	13	18
17	915.752	15	16	2	29	21	10
18	916.504	31	0	18	13	5	26
19	917.255	30	1	17	14	4	27
20	918.007	28	3	15	16	2	29
21	918.759	25	6	12	19	31	0
22	919.511	19	12	6	25	25	6
23	920.263	6	25	25	6	12	19
24	921.015	13	18	0	31	19	12
25	921.766	26	5	13	18	0	31
26	922.518						
27	923.270						
28	924.022						
29	924.774						
30	925.525						
31	926.277						

Figure 29: 25 Series RF Channels and Hop Sequences

**Power Mode - Address = 0x4D; NV Address = 0x02**

The value in the regPWRMODE register sets the module's output power.

Figure 30 shows the command and response and Figure 31 available power settings and typical power outputs for the module. The default setting is 0x03.

25 Series Power Mode						
<b>Read Command</b>				<b>Read Response</b>		
Header	Size	Escape	Address	ACK	Address	Value
0xFF	0x02	0xFE	0x4D 0x02	0x06	0x4D 0x02	PWR
<b>Write Command</b>						
Header	Size	Address	Value			
0xFF	0x02	0x4D 0x02	PWR			

Figure 30: 25 Series Power Mode Command and Response

25 Series Power Mode Register Settings		
PWR	Power Setting	Typical Output Power (dBm)
0x00	Low	-2
0x01	Mid - Low	+3
0x02	Mid - High	+8
0x03	High	+13

Figure 31: 25 Series Power Mode Settings

### UART Data Rate - Address = 0x4E; NV Address = 0x03

The value in regUARTDATARATE sets the data rate of the UART interface. Changing the non-volatile register changes the data rate on the following power-up or reset. Changing the volatile register changes the data rate immediately following the command acknowledgement. Figure 32 shows the command and response and Figure 33 shows the valid settings.

25 Series UART Data Rate							
<b>Read Command</b>				<b>Read Response</b>			
Header	Size	Escape	Address	ACK	Address	Value	
0xFF	0x02	0xFE	0x4E 0x03	0x06	0x4E 0x03	V1	
<b>Write Command</b>							
Header	Size	Address	Value				
0xFF	0x02	0x4E 0x03	V1				

Figure 32: 25 Series UART Data Rate Command and Response

25 Series UART Data Rate Register Settings	
V1	Baud Rate
0x00	2,400
0x01	9,600
0x02	19,200
0x03	38,400
0x04	57,600
0x05	115,200
0x06	10,400*
0x07	31,250*

\* These data rates are not supported by PC serial ports. Selection of these rates may cause the module to fail to respond to a PC, requiring a reset to factory defaults.

Figure 33: 25 Series UART Data Rate Settings

If the UART rate is different than the host processor UART rate then the module will not communicate correctly. If mismatched, every rate can be tested until the correct one is found or the module can be reset to factory defaults.

### Network Mode - Address = 0x4F; NV Address = 0x04

The module supports three networking modes: GUID, User, and Extended User. For each of these modes, assured delivery (acknowledgement) can be either enabled or disabled.

Figure 34 shows the command and response and Figure 35 shows the valid settings.

25 Series Network Mode							
<b>Read Command</b>				<b>Read Response</b>			
Header	Size	Escape	Address	ACK	Address	Value	
0xFF	0x02	0xFE	0x4F 0x04	0x06	0x4F 0x04	V1	
<b>Write Command</b>							
Header	Size	Address	Value				
0xFF	0x02	0x4F 0x04	V1				

Figure 34: 25 Series Network Mode Command and Response

25 Series Network Mode Register Settings	
Network Mode	Meaning
0x04	GUID Networking Mode
0x06	User Networking Mode
0x07	Extended User Networking Mode
0x14	GUID Networking Mode with Acknowledgement
0x16	User Networking Mode with Acknowledgement
0x17	Extended User Networking Mode with Acknowledgement

Figure 35: 25 Series Network Mode Register Settings

### Transmit Wait Timeout - Address = 0x50; NV Address = 0x05

When a byte is received from the UART, the module starts a timer that counts down every millisecond. The timer is restarted when each byte is received. The value for the regTXTO register is the number of milliseconds to wait before transmitting the data in the UART receive buffer. The default setting for this register is 0x10 (~16ms delay).

If the timer reaches zero before the next byte is received from the UART, the module begins transmitting the data in the buffer. This timeout value should be greater than one byte time at the current UART data rate with a minimum of 0x02. It should not be set to a value of 0x01 or any value less than one byte time as unpredictable results could occur.

If the timeout value is set to 0x00, the transmit wait timeout is deactivated. In this case, the transceiver waits until a number of bytes equal to the Minimum Transmission Unit (MTU) have been received by the UART. All of the bytes are sent once the MTU has been reached. Figure 36 shows examples of the commands. Figure 37 shows the minimum timeout values based on baud rate.

25 Series Transmit Wait Timeout						
Read Command				Read Response		
Header	Size	Escape	Address	ACK	Address	Value
0xFF	0x02	0xFE	0x50 0x05	0x06	0x50 0x05	V1
Write Command						
Header	Size	Address	Value			
0xFF	0x02	0x50 0x05	V1			

Figure 36: 25 Series Transmit Wait Timeout Command and Response

25 Series Minimum TXTO Values	
Baud Rate	Minimum TXTO
2,400	6ms
9,600	3ms
19,200	2ms
38,400	2ms
57,600	2ms
115,200	2ms

Figure 37: 25 Series Transmit Wait Timeout Minimum Values

### Maximum Transmit Retries - Address = 0x52; NV Address = 0x07

regMAXTXRETRY sets the number of transmission retries if an acknowledgement is not received. If an acknowledgement is not received after the last retry, EX\_NORFACK is raised. Figure 38 shows examples of the command.

25 Series Maximum Transmit Retries						
Read Command				Read Response		
Header	Size	Escape	Address	ACK	Address	Value
0xFF	0x02	0xFE	0x52 0x07	0x06	0x52 0x07	V1
Write Command						
Header	Size	Address	Value			
0xFF	0x02	0x52 0x07	V1			

Figure 38: 25 Series Maximum Transmit Retries Command and Response

The time between retries depends on the current baud rate. Figure 39 shows the time between retries based on baud rate. The retry number times the timeout times gives the potential latency before a new message can be sent.

25 Series Acknowledgement Timeout Times	
Baud Rate	EX_NORFACK Timeout
2400	170ms
9600	75ms
19200	45ms
38400	30ms
57600	30ms
115200	30ms

Figure 39: 25 Series Acknowledgement Timeout Times

### CRC Control - Address = 0x53; NV Address = 0x08

The 25 Series protocol includes a Cyclic Redundancy Check on the received packets to make sure that there are no errors. Any packets with errors are discarded and not output on the UART. This feature can be disabled if it is desired to perform error checking outside the module. Set the regUSECRC register to 0x01 to enable CRC checking, or 0x00 to disable it. The default CRC mode setting is enabled. Figure 40 shows examples of the commands and Figure 41 shows the available values.

25 Series CRC Control							
<b>Read Command</b>				<b>Read Response</b>			
Header	Size	Escape	Address	ACK	Address	Value	
0xFF	0x02	0xFE	0x53 0x08	0x06	0x53 0x08	V1	
<b>Write Command</b>							
Header	Size	Address	Value				
0xFF	0x02	0x53 0x08	V1				

Figure 40: 25 Series CRC Control Command and Response

25 Series CRC Control Register Settings	
V1	Mode
0x00	CRC Disabled
0x01	CRC Enabled

Figure 41: 25 Series CRC Control Register Settings

### UART Minimum Transmission Unit - Addr = 0x54; NV Addr = 0x09

This register determines the UART buffer level that triggers the transmission of a packet. The minimum value is decimal 1 and the maximum value is 192. The default value for this register is 64, which provides a good mix of throughput and latency. At the maximum data rate, a value of 128 optimizes throughput. This register does not guarantee a particular transmission unit size; rather, it specifies the minimum desired size. If there is not enough time left in a hop, for instance, the protocol engine sends as many characters as it can to fill the current hop, and sends the remaining characters in the next hop. Figure 42 shows examples of the commands.

25 Series UART MTU							
<b>Read Command</b>				<b>Read Response</b>			
Header	Size	Escape	Address	ACK	Address	Value	
0xFF	0x02	0xFE	0x54 0x09	0x06	0x54 0x09	V1	
<b>Write Command</b>							
Header	Size	Address	Value				
0xFF	0x02	0x54 0x09	V1				

Figure 42: 25 Series UART MTU Command and Response

### Show Version - Address = 0x0A

Setting this register to 0x00 suppresses the start-up message, including firmware version, which is sent to the UART when the module is reset. A value of 0x01 causes the message to be output after reset. By default, the module start-up message is output. Figure 43 shows examples of the commands and Figure 44 shows the available values.

25 Series Show Version							
Read Command				Read Response			
Header	Size	Escape	Address	ACK	Address	Value	
0xFF	0x02	0xFE	0x0A	0x06	0x0A	V1	
Write Command							
Header	Size	Address	Value				
0xFF	0x02	0x0A	V1				

Figure 43: 25 Series Show Version Command and Response

25 Series Show Version Settings	
V1	Meaning
0x00	Startup message is NOT output on reset or power-up.
0x01	Startup message is output on reset or power-up. This is a blocking call, and any incoming UART data is lost during the transmission of this message through the TXD line. All UART commands must be sent after this message has completed.
0x02	Startup message is displayed upon reset or power-up. This is a non-blocking call. Any incoming UART data is buffered, and incoming UART commands are processed. If a change of baud rate is commanded while the startup message is being output, the current byte finishes at the current baud rate, and subsequent bytes are transmitted at the new baud rate.

Figure 44: 25 Series Show Version Register Settings

### CSMA Enable - Address = 0x56; NV Address = 0x0B

Carrier-Sense Multiple Access (CSMA) is a transmission protocol that listens to the channel before transmitting a message. If another module is already transmitting when a message is queued, the module waits before sending its payload. This helps to eliminate RF message corruption at the expense of additional latency. Setting the regCSMAMODE register to 0x01 enables CSMA and 0x00 disables CSMA. By default, CSMA is enabled. Figure 45 shows examples of the commands and Figure 46 shows the available values.

25 Series CSMA Enable							
Read Command				Read Response			
Header	Size	Escape	Address	ACK	Address	Value	
0xFF	0x02	0xFE	0x56 0x0B	0x06	0x56 0x0B	V1	
Write Command							
Header	Size	Address	Value				
0xFF	0x02	0x56 0x0B	V1				

Figure 45: 25 Series CSMA Enable Command and Response

25 Series CSMA Enable Register Settings	
V1	Mode
0x00	Disable CSMA
0x01	Enable CSMA

Figure 46: 25 Series CSMA Enable Register Settings

### Operating Mode - Address = 0x58; NV Address = 0x0D

The value in the regOPMODE register sets the operating mode of the transceiver. If the module remains properly powered, and is awakened from a low power mode properly, the volatile registers retain their values when awakened. If the volatile registers become corrupted during low power, a software reset is forced and the module reboots.

Awake mode is the normal operating mode. This is the only mode in which the RF circuitry is able to receive and transmit RF messages.

Standby leaves the RF oscillator circuit operating for faster wakeup, whereas Sleep does not. One byte of 0x0F to the module's RXD line at the current baud rate wakes the modules.

Deep Sleep mode disables all circuitry on-board the module. This is the lowest-power mode available for the module. A low pulse on the  $\overline{\text{RESET}}$  line of at least 15 $\mu\text{s}$  wakes the module. The module begins the wake process once the  $\overline{\text{RESET}}$  line is returned high.

Please see the Low Power States section for more details. Figure 47 shows examples of the commands and Figure 48 shows the available values.

25 Series Operating Mode						
Read Command				Read Response		
Header	Size	Escape	Address	ACK	Address	Value
0xFF	0x02	0xFE	0x58 0x0D	0x06	0x58 0x0D	V1
Write Command						
Header	Size	Address	Value			
0xFF	0x02	0x58 0x0D	V1			

Figure 47: 25 Series Operating Mode Command and Response

25 Series Operating Mode Register Settings	
V1	Mode
0x00	Awake Mode
0x01	Sleep Mode
0x02	Standby Mode
0x03	Deep Sleep Mode

Figure 48: 25 Series Operating Mode Register Settings

### ACK on Wake - Address = 0x59; NV Address = 0x0E

When the module powers up and is ready for operation, it can output an acknowledge (ACK) character (0x06) on the TXD line. This indicates that the module is ready to accept data and commands. Setting this register to 0x00 disables the ACK, 0x01 enables the ACK. The default value is 0x01. Figure 49 shows examples of the commands and Figure 50 shows the available values.

25 Series ACK on Wake						
Read Command				Read Response		
Header	Size	Escape	Address	ACK	Address	Value
0xFF	0x02	0xFE	0x59 0x0E	0x06	0x59 0x0E	V1
Write Command						
Header	Size	Address	Value			
0xFF	0x02	0x59 0x0E	V1			

Figure 49: 25 Series ACK on Wake Command and Response

25 Series ACK on Wake Register Settings	
V1	Mode
0x00	Disable ACK
0x01	Enable ACK

Figure 50: 25 Series ACK on Wake Register Settings

## User Destination ID

These registers contain the address of the destination module when User Networking mode or Extended User Networking mode are enabled. User Networking mode uses bytes 0 and 1 to determine the destination address. Extended User Networking mode uses all four bytes. Please see the Networking Modes section for more details. Each register byte is read and written separately.

Figure 51 shows the User Destination ID Registers.

25 Series User Destination ID Registers			
Name	Volatile Address	Non-Volatile Address	Description
regUSERDESTID[3]	0x5A	0x0F	MSB of the extended destination address
regUSERDESTID[2]	0x5B	0x10	Byte 2 of the extended destination address
regUSERDESTID[1]	0x5C	0x11	Byte 1 of the extended destination address, MSB of the short destination address
regUSERDESTID[0]	0x5D	0x12	LSB of the extended destination address and short destination address

Figure 51: 25 Series User Destination ID Registers

## User Source ID

These registers contain the address of the source module when User Networking mode or Extended User Networking mode are enabled. User Networking mode uses bytes 0 and 1 to determine the source address. Extended User Networking mode uses all four bytes. Please see the Networking Modes section for more details. Each register byte is read and written separately.

Figure 52 shows the User Source ID Registers.

25 Series User Source ID Registers			
Name	Volatile Address	Non-Volatile Address	Description
regUSERSRCID[3]	0x5E	0x13	MSB of the extended source address
regUSERSRCID[2]	0x5F	0x14	Byte 2 of the extended source address
regUSERSRCID[1]	0x60	0x15	Byte 1 of the extended source address, MSB of the short source address
regUSERSRCID[0]	0x61	0x16	LSB of the extended source address and short source address

Figure 52: 25 Series User Source ID Registers

## User ID Mask

These registers contain the user ID mask when User Networking mode or Extended User Networking mode are enabled. User Networking mode uses bytes 0 and 1 and Extended User Networking mode uses all four bytes. Please see the Networking Modes section for more details. Each register byte is read and written separately.

Figure 53 shows the User ID Mask Registers.

25 Series User ID Mask Registers			
Name	Volatile Address	Non-Volatile Address	Description
regUSERIDMASK[3]	0x62	0x17	MSB of the extended mask
regUSERIDMASK[2]	0x63	0x18	Byte 2 of the extended mask
regUSERIDMASK[1]	0x64	0x19	Byte 1 of the extended mask, MSB of the short mask
regUSERIDMASK[0]	0x65	0x1A	LSB of the extended mask and short mask

Figure 53: 25 Series User ID Mask Registers

## Destination GUID

These registers contain the address of the destination module when MAC Networking Mode is enabled. Please see the Networking Modes section for more details. Each register byte is read and written separately.

Figure 54 shows the Destination ID Registers.

25 Series Destination GUID Registers			
Name	Volatile Address	Non-Volatile Address	Description
regDESTGUID[3]	0x68	0x1D	MSB of the destination GUID
regDESTGUID[2]	0x69	0x1E	Byte 2 of the destination GUID
regDESTGUID[1]	0x6A	0x1F	Byte 1 of the destination GUID, MSB of the short destination GUID
regDESTGUID[0]	0x6B	0x20	LSB of the extended and short destination GUID

Figure 54: 25 Series Destination GUID Registers

### Exception Mask - Address = 0x6C; NV Address = 0x21

The module has a built-in exception engine that can notify the host processor of an unexpected event. When an exception occurs, this register is ANDed with the exception code. A non-zero result causes the EX line to be asserted. Reading the regEXCEPTION register clears the exception and resets the EX line. If the result is zero, the EX line is not asserted but the exception code is stored in the regEXCEPTION register.

Figure 55 shows examples of the commands and Figure 56 shows the available values.

25 Series Exception Masks							
Read Command				Read Response			
Header	Size	Escape	Address	ACK	Address	Value	
0xFF	0x02	0xFE	0x6C 0x21	0x06	0x6C 0x21	V1	
Write Command							
Header	Size	Address	Value				
0xFF	0x02	0x6C 0x21	V1				

Figure 55: 25 Series Transceiver Exception Masks Command and Response

25 Series Example Exception Masks	
V1	Exception Name
0x08	Allows only EX_BUFOVFL and EX_RFOVFL to trigger the EX line
0x10	Allows only EX_WRITEREGFAILED to trigger the EX line
0x20	Allows only EX_NORFACK to trigger the EX line
0x40	Allows only EX_BADCRC, EX_BADHEADER, EX_BADSEQID and EX_BADFRAMETYPE exceptions to trigger the EX line
0x60	Allows EX_BADCRC, EX_BADHEADER, EX_BADSEQID, EX_BADFRAMETYPE and EX_NORFACK exceptions to trigger the EX line
0xFF	Allows all exceptions to trigger the EX line

Figure 56: 25 Series Transceiver Example Exception Masks

### CMD Halts Traffic- Address = 0x6E; NV Address = 0x23

When configuring the module's register settings, it is possible that incoming RF transmissions can intermix with the module's response, making it difficult to determine if your commands were successfully processed. Changing this register setting to 0x01 causes the module to store incoming RF traffic (up to the RF buffer overflow) while the  $\overline{\text{CMD}}$  line is low. When the  $\overline{\text{CMD}}$  line is returned high, the module outputs all buffered data.

Figure 57 shows examples of the commands and Figure 58 shows the available values.

25 Series $\overline{\text{CMD}}$ Halts Traffic							
Read Command				Read Response			
Header	Size	Escape	Address	ACK	Address	Value	
0xFF	0x02	0xFE	0x6E 0x23	0x06	0x6E 0x23	V1	
Write Command							
Header	Size	Address	Value				
0xFF	0x02	0x6E 0x23	V1				

Figure 57: 25 Series Transceiver  $\overline{\text{CMD}}$  Halts Traffic Command and Response

25 Series $\overline{\text{CMD}}$ Halts Traffic Register Settings	
V1	Mode
0x00	Disable Halt
0x01	Enable Halt

Figure 58: 25 Series  $\overline{\text{CMD}}$  Halts Traffic Register Settings

### Receiver LNA Mode - Address = 0x6F; NV Address = 0x24

By default, the module is factory-configured for maximum receiver sensitivity. Reducing the gain increases the linearity of the receiver, but reduces maximum sensitivity; increasing the gain does the opposite. Generally speaking, higher linearity (increased third order input intercept point, IIP3) gives improved performance in high-interference environments; high gain yields better performance in low-interference environments.

Figure 59 shows examples of the commands and Figure 60 shows the available values.

25 Series LNA Mode							
<b>Read Command</b>				<b>Read Response</b>			
Header	Size	Escape	Address	ACK	Address	Value	
0xFF	0x02	0xFE	0x6F 0x24	0x06	0x6F 0x24	V1	
<b>Write Command</b>							
Header	Size	Address	Value				
0xFF	0x02	0x6F 0x24	V1				

Figure 59: 25 Series Transceiver LNA Mode Command and Response

25 Series LNA Mode Register Settings			
V1	Meaning	IIP3 Increase	Sensitivity Decrease
0x00	AGC Enabled	Variable	Variable
0x01	High Sensitivity	Reference	Reference
0x02	Mid Linearity	19.1dB	6.5dB
0x03	High Linearity	41.8dB	9.5dB

Figure 60: 25 Series Transceiver LNA Mode Register Settings

### Compatibility Mode - Address = 0x70; NV Address = 0x25

Compatibility mode allows the 25 Series modules to communicate with the 250 Series modules. Please see the Compatibility Mode section for more details. Figure 61 shows examples of the commands and Figure 62 shows the available values.

25 Series Compatibility Mode							
<b>Read Command</b>				<b>Read Response</b>			
Header	Size	Escape	Address	ACK	Address	Value	
0xFF	0x02	0xFE	0x70 0x25	0x06	0x70 0x25	V1	
<b>Write Command</b>							
Header	Size	Address	Value				
0xFF	0x02	0x70 0x25	V1				

Figure 61: 25 Series Transceiver Compatibility Mode Command and Response

25 Series Compatibility Mode Register Settings	
V1	Mode
0x00	Disable Compatibility Mode
0x01	Enable Compatibility Mode

Figure 62: 25 Series Compatibility Mode Register Settings

### Auto Addressing - Address = 0x71; NV Address = 0x26

When this register is enabled, the module reads the Source Address from a received packet and uses it to fill the Destination Address registers. This makes sure that a response is sent to the device that transmitted the original message.

The non-volatile register only uses the lower 4 bits to configure the automatic addressing. The upper 4 bits are not used.

The volatile register is split in half with the lower 4 bits configuring the automatic addressing, the same as the non-volatile register.

The upper 4 bits indicate the type of packet that was last received. This indication is the same as the Network Mode register setting. These bits are not used by the module and are only written by the module after successfully receiving a packet.

As an example, if regAUTADD is set to 0x0F (Any Auto Address) and a GUID packet is received from another module, then regAUTADD reads back as 0x4F. The lower 4 bits indicate that the module is set to any auto address (0xF). The upper 4 bits indicate that the packet that was just received was a GUID Network Mode packet (0x4).

Figure 63 summarizes the configuration values for the lower 4 bits of the register.

250 Series Auto Address Register Settings		
Auto Address Mode	Meaning	Action
0x00	Auto Address Mode disabled	Destination Registers not populated
0x04	GUID Auto Address Mode	Auto-populates GUID Address Destination Register Only
0x06	User Auto Address Mode	Auto-populates User Address Destination Register
0x07	Extended User Auto Address Mode	Auto-populates User Address Destination Register
0x0F	Any Auto Address Mode	Auto-populates GUID Address Destination Register

Figure 63: 25 Series Transceiver Auto Address Mode Register Settings

Figure 64 shows the Network Mode values that the module writes to the upper 4 bits after successfully receiving a packet.

25 Series Auto Addressing Network Mode Indicator	
Network Mode	Meaning
0x4	GUID Networking Mode
0x6	User Networking Mode
0x7	Extended User Networking Mode

Figure 64: 25 Series Transceiver Auto Addressing Network Mode Indicator

## My GUID

These registers contain the factory-programmed read-only GUID address. This address is unique for each module and is used by all packet types as a unique origination address.

Figure 65 shows the GUID Registers.

25 Series GUID Registers		
Name	Non-Volatile Address	Description
regMYGUID[3]	0x34	MSB of the GUID address
regMYGUID[2]	0x35	Byte 2 of the GUID address
regMYGUID[1]	0x36	Byte 1 of the GUID address
regMYGUID[0]	0x37	LSB of the GUID address

Figure 65: 25 Series GUID Registers

## Release Number - NV Address = 0x78

This register contains a hard-coded release number corresponding to a firmware version and hardware platform. Figure 66 shows examples of the commands and Figure 67 lists current releases to date.

25 Series Release Number						
Read Command				Read Response		
Header	Size	Escape	Address	ACK	Address	Value
0xFF	0x02	0xFE	0x78	0x06	0x78	V1

Figure 66: 25 Series Transceiver Release Number Command and Response

25 Series Release Number Register Settings	
V1	Release Number
0x08	1.0.0
0x0A	1.0.2
0x0C	1.0.4
0x0E	1.0.4a
0x0F	1.0.5

Figure 67: 25 Series Transceiver Release Number Register Settings

### Exception - Address = 0x79

The module has a built-in exception engine that can notify the host processor of an unexpected event. If an exception occurs, the exception code is stored in this register. Reading from this register clears the exception and, if applicable, resets the EX line. If an exception occurs before the previous exception code is read, the previous value is overwritten. Figure 68 shows examples of the commands and Figure 69 shows the available values.

25 Series Exception						
Read Command				Read Response		
Header	Size	Escape	Address	ACK	Address	Value
0xFF	0x02	0xFE	0x79	0x06	0x79	V1

Figure 68: 25 Series Transceiver Exception Command and Response

25 Series Transceiver Exception Codes		
V1	Exception Name	Description
0x08	EX_BUFOVFL	Internal UART buffers overflowed.
0x09	EX_RFOVFL	Internal RF packet buffer overflowed.
0x13	EX_WRITEREGFAILED	Attempted write to register failed.
0x20	EX_NORFACK	Acknowledgement packet not received after maximum number of retries.
0x40	EX_BADCRC	Bad CRC detected on incoming packet.
0x42	EX_BADHEADER	Bad CRC detected in packet header.
0x43	EX_BADSEQID	Sequence ID was incorrect in ACK packet.
0x44	EX_BADFRAMETYPE	Unsupported frame type specified.

Figure 69: 25 Series Transceiver Exception Codes

### Custom ID

These registers contain the factory-programmed custom ID. A value is assigned to OEM customer with a custom version of the module. Contact Linx for details. Figure 70 shows the GUID Registers.

25 Series Custom ID Registers		
Name	Non-Volatile Address	Description
regCUSTID[1]	0x39	MSB of the custom ID
regCUSTID[0]	0x3A	LSB of the custom ID

Figure 70: 250 Series Transceiver Custom ID

### Last Good Packet RSSI - Address = 0x7B

This register holds the received signal strength in dBm of the last successful received packet. A successful packet reception is one that causes payload data to be output on the UART interface. The value in this register is overwritten each time a new packet is successfully processed. The register value is an 8-bit signed integer representing the RSSI in dBm. It is accurate to  $\pm 3$ dB and has  $\pm 2$ dB linearity. The values take the LNA gain into account.

25 Series Last Good Packet RSSI						
Read Command				Read Response		
Header	Size	Escape	Address	ACK	Address	Value
0xFF	0x02	0xFE	0x7B	0x06	0x7B	V1

Figure 71: 25 Series Transceiver Last Good Packet RSSI Command and Response

### Immediate RSSI - Address = 0x7C

This register returns the current receive signal strength indication in dBm. The signal strength is measured as soon as the command is registered and the value is loaded into the regIMMEDIORSSI register. The register value is an 8-bit signed integer representing the RSSI in dBm. It is accurate to  $\pm 3$ dB and has  $\pm 2$ dB linearity. The values take the LNA gain into account.

25 Series Immediate RSSI						
Read Command				Read Response		
Header	Size	Escape	Address	ACK	Address	Value
0xFF	0x02	0xFE	0x7C	0x06	0x7C	V1

Figure 72: 25 Series Transceiver Immediate RSSI Command and Response

## Typical Applications

Figure 73 shows a circuit using the 25 Series transceiver.

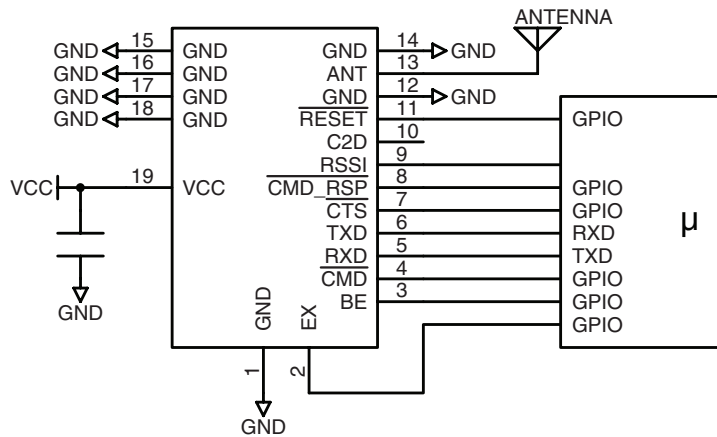

Figure 73: 25 Series Transceiver Basic Application Circuit

The transceiver UART is connected to a microcontroller UART for communication of configuration data and data to be sent over the air. The microcontroller is connected to the  $\overline{\text{CMD-RSP}}$ , EX,  $\overline{\text{CMD}}$ , BE and  $\overline{\text{CTS}}$  lines to monitor the current state of the module. It monitors the RSSI line to monitor the strength of the incoming RF signal.

There is no need for buffering or other circuitry between the transceiver and microcontroller provided that both are operating on the same voltage.

## Power Supply Requirements

The module does not have an internal voltage regulator, therefore it requires a clean, well-regulated power source. The power supply noise should be less than 20mV. Power supply noise can significantly affect the module's performance, so providing a clean power supply for the module should be a high priority during design.

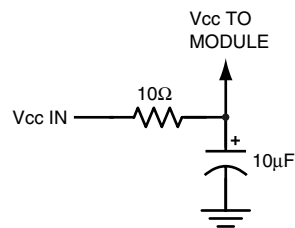

Figure 74: Supply Filter

A 10Ω resistor in series with the supply followed by a 10μF tantalum capacitor from  $V_{cc}$  to ground helps in cases where the quality of supply power is poor (Figure 74). This filter should be placed close to the module's supply lines. These values may need to be adjusted depending on the noise present on the supply line.

## Antenna Considerations

The choice of antennas is a critical and often overlooked design consideration. The range, performance and legality of an RF link are critically dependent upon the antenna. While adequate antenna performance can often be obtained by trial and error methods, antenna design and matching is a complex task.



Figure 75: Linx Antennas

Professionally designed antennas such as those from Linx (Figure 75) help ensure maximum performance and FCC and other regulatory compliance.

Linx transmitter modules typically have an output power that is higher than the legal limits. This allows the designer to use an inefficient antenna such as a loop trace or helical to meet size, cost or cosmetic requirements and still achieve full legal output power for maximum range. If an efficient antenna is used, then some attenuation may be needed.

It is usually best to utilize a basic quarter-wave whip until your prototype product is operating satisfactorily. Other antennas can then be evaluated based on the cost, size and cosmetic requirements of the product.

## Helpful Application Notes from Linx

It is not the intention of this manual to address in depth many of the issues that should be considered to ensure that the modules function correctly and deliver the maximum possible performance. We recommend reading the application notes listed in Figure 76 which address in depth key areas of RF design and application of Linx products. These applications notes are available online at [www.linxtechnologies.com](http://www.linxtechnologies.com) or by contacting the Linx literature department.

Helpful Application Note Titles	
Note Number	Note Title
AN-00100	RF 101: Information for the RF Challenged
AN-00126	Considerations for Operation Within the 902–928MHz Band
AN-00130	Modulation Techniques for Low-Cost RF Data Links
AN-00140	The FCC Road: Part 15 from Concept to Approval
AN-00500	Antennas: Design, Application, Performance
AN-00501	Understanding Antenna Specifications and Operation

Figure 76: Helpful Application Note Titles

## Interference Considerations

The RF spectrum is crowded and the potential for conflict with unwanted sources of RF is very real. While all RF products are at risk from interference, its effects can be minimized by better understanding its characteristics.

Interference may come from internal or external sources. The first step is to eliminate interference from noise sources on the board. This means paying careful attention to layout, grounding, filtering and bypassing in order to eliminate all radiated and conducted interference paths. For many products, this is straightforward; however, products containing components such as switching power supplies, motors, crystals and other potential sources of noise must be approached with care. Comparing your own design with a Linx evaluation board can help to determine if and at what level design-specific interference is present.

External interference can manifest itself in a variety of ways. Low-level interference produces noise and hashing on the output and reduces the link's overall range.

High-level interference is caused by nearby products sharing the same frequency or from near-band high-power devices. It can even come from your own products if more than one transmitter is active in the same area. It is important to remember that only one transmitter at a time can occupy a frequency, regardless of the coding of the transmitted signal. This type of interference is less common than those mentioned previously, but in severe cases it can prevent all useful function of the affected device.

Although technically not interference, multipath is also a factor to be understood. Multipath is a term used to refer to the signal cancellation effects that occur when RF waves arrive at the receiver in different phase relationships. This effect is a particularly significant factor in interior environments where objects provide many different signal reflection paths. Multipath cancellation results in lowered signal levels at the receiver and shorter useful distances for the link.

## Microstrip Details

A transmission line is a medium whereby RF energy is transferred from one place to another with minimal loss. This is a critical factor, especially in high-frequency products like Linx RF modules, because the trace leading to the module's antenna can effectively contribute to the length of the antenna, changing its resonant bandwidth. In order to minimize loss and detuning, some form of transmission line between the antenna and the module should be used unless the antenna can be placed very close (<1/8in) to the module. One common form of transmission line is a coax cable and another is the microstrip. This term refers to a PCB trace running over a ground plane that is designed to serve as a transmission line between the module and the antenna. The width is based on the desired characteristic impedance of the line, the thickness of the PCB and the dielectric constant of the board material. For standard 0.062in thick FR-4 board material, the trace width would be 111 mils. The correct trace width can be calculated for other widths and materials using the information in Figure 77 and examples are provided in Figure 78. Software for calculating microstrip lines is also available on the Linx website.

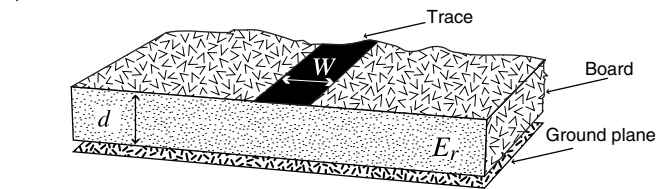

$$E_e = \frac{E_r + 1}{2} + \frac{E_r - 1}{2} \cdot \frac{1}{\sqrt{1 + 12d/W}}$$

$$Z_0 = \begin{cases} \frac{60}{\sqrt{E_e}} \cdot \ln\left(\frac{8d}{W} + \frac{W}{4d}\right) & \text{For } \frac{W}{d} \leq 1 \\ \frac{120\pi}{\sqrt{E_e} \cdot \left(\frac{W}{d} + 1.393 + 0.667 \cdot \ln\left(\frac{W}{d} + 1.444\right)\right)} & \text{For } \frac{W}{d} \geq 1 \end{cases}$$

$E_r$  = Dielectric constant of PCB material

Figure 77: Microstrip Formulas

Example Microstrip Calculations			
Dielectric Constant	Width / Height Ratio (W / d)	Effective Dielectric Constant	Characteristic Impedance (Ω)
4.80	1.8	3.59	50.0
4.00	2.0	3.07	51.0
2.55	3.0	2.12	48.8

Figure 78: Example Microstrip Calculations

## Pad Layout

The pad layout diagram in Figure 79 is designed to facilitate both hand and automated assembly.

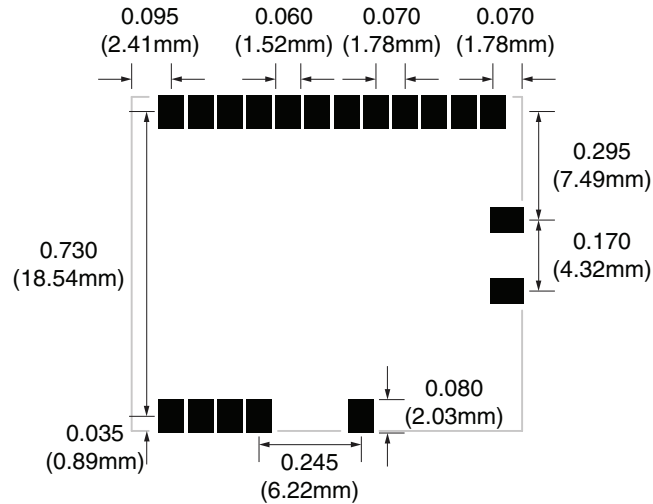

Figure 79: Recommended PCB Layout

## Board Layout Guidelines

The module's design makes integration straightforward; however, it is still critical to exercise care in PCB layout. Failure to observe good layout techniques can result in a significant degradation of the module's performance. A primary layout goal is to maintain a characteristic 50-ohm impedance throughout the path from the antenna to the module. Grounding, filtering, decoupling, routing and PCB stack-up are also important considerations for any RF design. The following section provides some basic design guidelines.

During prototyping, the module should be soldered to a properly laid-out circuit board. The use of prototyping or "perf" boards results in poor performance and is strongly discouraged. Likewise, the use of sockets can have a negative impact on the performance of the module and is discouraged.

The module should, as much as reasonably possible, be isolated from other components on your PCB, especially high-frequency circuitry such as crystal oscillators, switching power supplies, and high-speed bus lines.

When possible, separate RF and digital circuits into different PCB regions.

Make sure internal wiring is routed away from the module and antenna and is secured to prevent displacement.

Do not route PCB traces directly under the module. There should not be any copper or traces under the module on the same layer as the module, just bare PCB. The underside of the module has traces and vias that could short or couple to traces on the product's circuit board.

The Pad Layout section shows a typical PCB footprint for the module. A ground plane (as large and uninterrupted as possible) should be placed on a lower layer of your PCB opposite the module. This plane is essential for creating a low impedance return for ground and consistent stripline performance.

Use care in routing the RF trace between the module and the antenna or connector. Keep the trace as short as possible. Do not pass it under the module or any other component. Do not route the antenna trace on multiple PCB layers as vias add inductance. Vias are acceptable for tying together ground layers and component grounds and should be used in multiples.

Each of the module's ground pins should have short traces tying immediately to the ground plane through a via.

Bypass caps should be low ESR ceramic types and located directly adjacent to the pin they are serving.

A 50-ohm coax should be used for connection to an external antenna. A 50-ohm transmission line, such as a microstrip, stripline or coplanar waveguide should be used for routing RF on the PCB. The Microstrip Details section provides additional information.

In some instances, a designer may wish to encapsulate or "pot" the product. There are a wide variety of potting compounds with varying dielectric properties. Since such compounds can considerably impact RF performance and the ability to rework or service the product, it is the responsibility of the designer to evaluate and qualify the impact and suitability of such materials.

## Production Guidelines

The module is housed in a hybrid SMD package that supports hand and automated assembly techniques. Since the modules contain discrete components internally, the assembly procedures are critical to ensuring the reliable function of the modules. The following procedures should be reviewed with and practiced by all assembly personnel.

## Hand Assembly

Pads located on the bottom of the module are the primary mounting surface (Figure 80). Since these pads are inaccessible during mounting, castellations that run up the side of the module have been provided to facilitate solder wicking to the module's underside. This allows for very

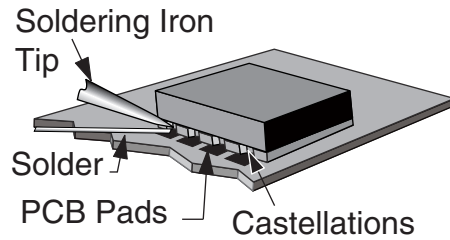

Figure 80: Soldering Technique

quick hand soldering for prototyping and small volume production. If the recommended pad guidelines have been followed, the pads will protrude slightly past the edge of the module. Use a fine soldering tip to heat the board pad and the castellation, then introduce solder to the pad at the module's edge. The solder will wick underneath the module, providing reliable attachment. Tack one module corner first and then work around the device, taking care not to exceed the times in Figure 81.

**Warning:** Pay attention to the absolute maximum solder times.

### Absolute Maximum Solder Times

Hand Solder Temperature: +427°C for 10 seconds for lead-free alloys

Reflow Oven: +255°C max (see Figure 82)

Figure 81: Absolute Maximum Solder Times

## Automated Assembly

For high-volume assembly, the modules are generally auto-placed. The modules have been designed to maintain compatibility with reflow processing techniques; however, due to their hybrid nature, certain aspects of the assembly process are far more critical than for other component types. Following are brief discussions of the three primary areas where caution must be observed.

## Reflow Temperature Profile

The single most critical stage in the automated assembly process is the reflow stage. The reflow profile in Figure 82 should not be exceeded because excessive temperatures or transport times during reflow will irreparably damage the modules. Assembly personnel need to pay careful attention to the oven's profile to ensure that it meets the requirements necessary to successfully reflow all components while still remaining within the limits mandated by the modules. The figure below shows the recommended reflow oven profile for the modules.

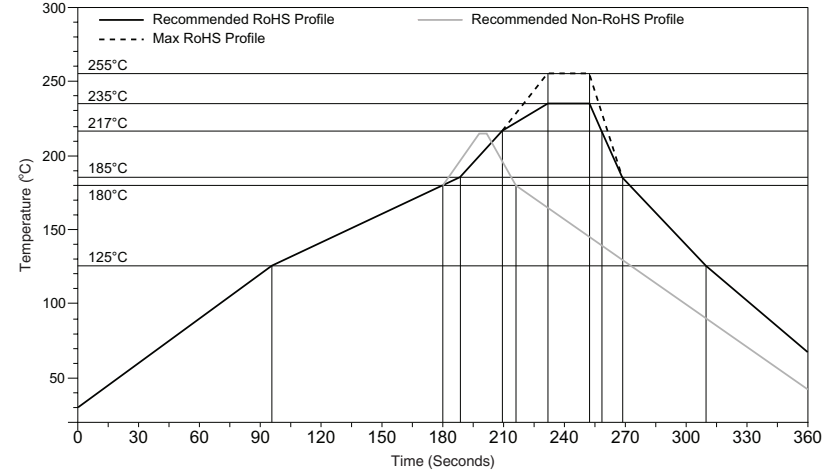

Figure 82: Maximum Reflow Temperature Profile

## Shock During Reflow Transport

Since some internal module components may reflow along with the components placed on the board being assembled, it is imperative that the modules not be subjected to shock or vibration during the time solder is liquid. Should a shock be applied, some internal components could be lifted from their pads, causing the module to not function properly.

## Washability

The modules are wash-resistant, but are not hermetically sealed. Linx recommends wash-free manufacturing; however, the modules can be subjected to a wash cycle provided that a drying time is allowed prior to applying electrical power to the modules. The drying time should be sufficient to allow any moisture that may have migrated into the module to evaporate, thus eliminating the potential for shorting damage during power-up or testing. If the wash contains contaminants, the performance may be adversely affected, even after drying.

## General Antenna Rules

The following general rules should help in maximizing antenna performance.

1. Proximity to objects such as a user's hand, body or metal objects will cause an antenna to detune. For this reason, the antenna shaft and tip should be positioned as far away from such objects as possible.
2. Optimum performance is obtained from a  $\frac{1}{4}$ - or  $\frac{1}{2}$ -wave straight whip mounted at a right angle to the ground plane (Figure 83). In many cases, this isn't desirable for practical or ergonomic reasons, thus, an alternative antenna style such as a helical, loop or patch may be utilized and the corresponding sacrifice in performance accepted.

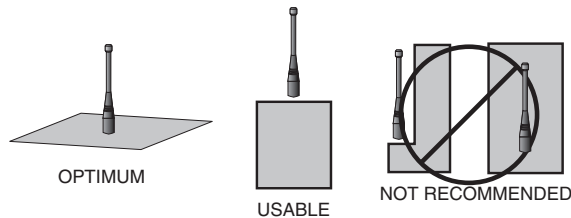

Figure 83: Ground Plane Orientation

3. If an internal antenna is to be used, keep it away from other metal components, particularly large items like transformers, batteries, PCB tracks and ground planes. In many cases, the space around the antenna is as important as the antenna itself. Objects in close proximity to the antenna can cause direct detuning, while those farther away will alter the antenna's symmetry.
4. In many antenna designs, particularly  $\frac{1}{4}$ -wave whips, the ground plane acts as a counterpoise, forming, in essence, a  $\frac{1}{2}$ -wave dipole (Figure 84). For this reason, adequate ground plane area is essential. The ground plane can be a metal case or ground-fill areas on a circuit board. Ideally, it should have a surface area less than or equal to the overall length of the  $\frac{1}{4}$ -wave radiating element. This is often not practical due to size and configuration constraints. In these instances, a designer must make the best use of the area available to create as much ground

### VERTICAL $\frac{1}{4}$ GROUNDED ANTENNA (MARCONI)

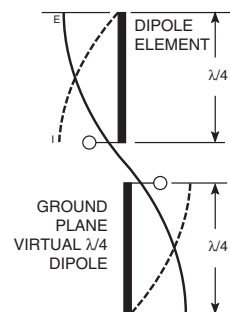

Figure 84: Dipole Antenna

plane as possible in proximity to the base of the antenna. In cases where the antenna is remotely located or the antenna is not in close proximity to a circuit board, ground plane or grounded metal case, a metal plate may be used to maximize the antenna's performance.

5. Remove the antenna as far as possible from potential interference sources. Any frequency of sufficient amplitude to enter the receiver's front end will reduce system range and can even prevent reception entirely. Switching power supplies, oscillators or even relays can also be significant sources of potential interference. The single best weapon against such problems is attention to placement and layout. Filter the module's power supply with a high-frequency bypass capacitor. Place adequate ground plane under potential sources of noise to shunt noise to ground and prevent it from coupling to the RF stage. Shield noisy board areas whenever practical.
6. In some applications, it is advantageous to place the module and antenna away from the main equipment (Figure 85). This can avoid interference problems and allows the antenna to be oriented for optimum performance. Always use  $50\Omega$  coax, like RG-174, for the remote feed.

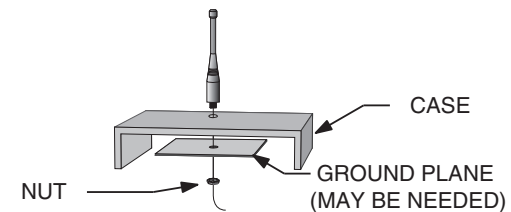

Figure 85: Remote Ground Plane

## Common Antenna Styles

There are hundreds of antenna styles and variations that can be employed with Linx RF modules. Following is a brief discussion of the styles most commonly utilized. Additional antenna information can be found in Linx Application Notes AN-00100, AN-00140, AN-00500 and AN-00501. Linx antennas and connectors offer outstanding performance at a low price.

### Whip Style

A whip style antenna (Figure 86) provides outstanding overall performance and stability. A low-cost whip can be easily fabricated from a wire or rod, but most designers opt for the consistent performance and cosmetic appeal of a professionally-made model. To meet this need, Linx offers a wide variety of straight and reduced height whip style antennas in permanent and connectorized mounting styles.



Figure 86: Whip Style Antennas

The wavelength of the operational frequency determines an antenna's overall length. Since a full wavelength is often quite long, a partial 1/2- or 1/4-wave antenna is normally employed. Its size and natural radiation resistance make it well matched to Linx modules. The proper length for a straight 1/4-wave can be easily determined using the formula in Figure 87. It is also possible to reduce the overall height of the antenna by using a helical winding. This reduces the antenna's bandwidth but is a great way to minimize the antenna's physical size for compact applications. This also means that the physical appearance is not always an indicator of the antenna's frequency.

$$L = \frac{234}{F_{\text{MHz}}}$$

Figure 87:  
L = length in feet of quarter-wave length  
F = operating frequency in megahertz

### Specialty Styles

Linx offers a wide variety of specialized antenna styles (Figure 88). Many of these styles utilize helical elements to reduce the overall antenna size while maintaining reasonable performance. A helical antenna's bandwidth is often quite narrow and the antenna can detune in proximity to other objects, so care must be exercised in layout and placement.



Figure 88: Specialty Style Antennas

### Loop Style

A loop or trace style antenna is normally printed directly on a product's PCB (Figure 89). This makes it the most cost-effective of antenna styles. The element can be made self-resonant or externally resonated with discrete components, but its actual layout is usually product specific. Despite the cost advantages, loop style antennas are generally inefficient and useful only for short range applications. They are also very sensitive to changes in layout and PCB dielectric, which can cause consistency issues during production. In addition, printed styles are difficult to engineer, requiring the use of expensive equipment including a network analyzer. An improperly designed loop will have a high VSWR at the desired frequency which can cause instability in the RF stage.

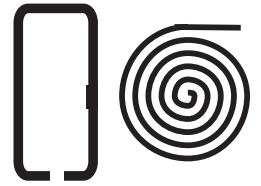

Figure 89: Loop or Trace Antenna

Linx offers low-cost planar (Figure 90) and chip antennas that mount directly to a product's PCB. These tiny antennas do not require testing and provide excellent performance despite their small size. They offer a preferable alternative to the often problematic "printed" antenna.

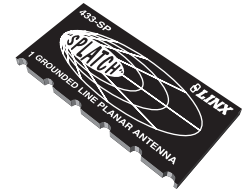

Figure 90: SP Series "Splatch" Antenna

## Regulatory Considerations

**Note:** Linx RF modules are designed as component devices that require external components to function. The purchaser understands that additional approvals may be required prior to the sale or operation of the device, and agrees to utilize the component in keeping with all laws governing its use in the country of operation.

When working with RF, a clear distinction must be made between what is technically possible and what is legally acceptable in the country where operation is intended. Many manufacturers have avoided incorporating RF into their products as a result of uncertainty and even fear of the approval and certification process. Here at Linx, our desire is not only to expedite the design process, but also to assist you in achieving a clear idea of what is involved in obtaining the necessary approvals to legally market a completed product.

For information about regulatory approval, read AN-00142 on the Linx website or call Linx. Linx designs products with worldwide regulatory approval in mind.

In the United States, the approval process is actually quite straightforward. The regulations governing RF devices and the enforcement of them are the responsibility of the Federal Communications Commission (FCC). The regulations are contained in Title 47 of the United States Code of Federal Regulations (CFR). Title 47 is made up of numerous volumes; however, all regulations applicable to this module are contained in Volume 0-19. It is strongly recommended that a copy be obtained from the FCC's website, the Government Printing Office in Washington or from your local government bookstore. Excerpts of applicable sections are included with Linx evaluation kits or may be obtained from the Linx Technologies website, [www.linxtechnologies.com](http://www.linxtechnologies.com). In brief, these rules require that any device that intentionally radiates RF energy be approved, that is, tested for compliance and issued a unique identification number. This is a relatively painless process. Final compliance testing is performed by one of the many independent testing laboratories across the country. Many labs can also provide other certifications that the product may require at the same time, such as UL, CLASS A / B, etc. Once the completed product has passed, an ID number is issued that is to be clearly placed on each product manufactured.

Questions regarding interpretations of the Part 2 and Part 15 rules or the measurement procedures used to test intentional radiators such as Linx RF modules for compliance with the technical standards of Part 15 should be addressed to:

Federal Communications Commission  
Equipment Authorization Division  
Customer Service Branch, MS 1300F2  
7435 Oakland Mills Road  
Columbia, MD, US 21046  
Phone: + 1 301 725 585 | Fax: + 1 301 344 2050  
Email: [labinfo@fcc.gov](mailto:labinfo@fcc.gov)

ETSI Secretaria  
650, Route des Lucioles  
06921 Sophia-Antipolis Cedex  
FRANCE  
Phone: +33 (0)4 92 94 42 00  
Fax: +33 (0)4 93 65 47 16

International approvals are slightly more complex, although Linx modules are designed to allow all international standards to be met. If the end product is to be exported to other countries, contact Linx to determine the specific suitability of the module to the application.

All Linx modules are designed with the approval process in mind and thus much of the frustration that is typically experienced with a discrete design is eliminated. Approval is still dependent on many factors, such as the choice of antennas, correct use of the frequency selected and physical packaging. While some extra cost and design effort are required to address these issues, the additional usefulness and profitability added to a product by RF makes the effort more than worthwhile.

## Resources

### Support

For technical support, product documentation, application notes, regulatory guidelines and software updates, visit [www.linstechnologies.com](http://www.linstechnologies.com)

### RF Design Services

For customers who need help implementing Linx modules, Linx offers design services including board layout assistance, programming, certification advice and packaging design. For more complex RF solutions, Apex Wireless, a division of Linx Technologies, creates optimized designs with RF components and firmware selected for the customer's application. Call +1 800 736 6677 (+1 541 471 6256 if outside the United States) for more information.

### Antenna Factor Antennas

Linx's Antenna Factor division has the industry's broadest selection of antennas for a wide variety of applications. For customers with specialized needs, custom antennas and design services are available along with simulations of antenna performance to speed development. Learn more at [www.linstechnologies.com](http://www.linstechnologies.com),





Linx Technologies  
159 Ort Lane  
Merlin, OR, US 97532

Phone: +1 541 471 6256  
Fax: +1 541 471 6251

[www.linxtechnologies.com](http://www.linxtechnologies.com)

---

#### Disclaimer

Linx Technologies is continually striving to improve the quality and function of its products. For this reason, we reserve the right to make changes to our products without notice. The information contained in this Data Guide is believed to be accurate as of the time of publication. Specifications are based on representative lot samples. Values may vary from lot-to-lot and are not guaranteed. "Typical" parameters can and do vary over lots and application. Linx Technologies makes no guarantee, warranty, or representation regarding the suitability of any product for use in any specific application. It is the customer's responsibility to verify the suitability of the part for the intended application. **NO LINX PRODUCT IS INTENDED FOR USE IN ANY APPLICATION WHERE THE SAFETY OF LIFE OR PROPERTY IS AT RISK.**

Linx Technologies **DISCLAIMS ALL WARRANTIES OF MERCHANTABILITY AND FITNESS FOR A PARTICULAR PURPOSE. IN NO EVENT SHALL LINX TECHNOLOGIES BE LIABLE FOR ANY OF CUSTOMER'S INCIDENTAL OR CONSEQUENTIAL DAMAGES ARISING IN ANY WAY FROM ANY DEFECTIVE OR NON-CONFORMING PRODUCTS OR FOR ANY OTHER BREACH OF CONTRACT BY LINX TECHNOLOGIES.** The limitations on Linx Technologies' liability are applicable to any and all claims or theories of recovery asserted by Customer, including, without limitation, breach of contract, breach of warranty, strict liability, or negligence. Customer assumes all liability (including, without limitation, liability for injury to person or property, economic loss, or business interruption) for all claims, including claims from third parties, arising from the use of the Products. The Customer will indemnify, defend, protect, and hold harmless Linx Technologies and its officers, employees, subsidiaries, affiliates, distributors, and representatives from and against all claims, damages, actions, suits, proceedings, demands, assessments, adjustments, costs, and expenses incurred by Linx Technologies as a result of or arising from any Products sold by Linx Technologies to Customer. Under no conditions will Linx Technologies be responsible for losses arising from the use or failure of the device in any application, other than the repair, replacement, or refund limited to the original product purchase price. Devices described in this publication may contain proprietary, patented, or copyrighted techniques, components, or materials. Under no circumstances shall any user be conveyed any license or right to the use or ownership of such items.

---

©2015 Linx Technologies. All rights reserved.

The stylized Linx logo, Wireless Made Simple, WISE, CipherLinx and the stylized CL logo are trademarks of Linx Technologies.