



**Pumped Storage
Hydropower**
International Forum



**Capabilities,
Costs & Innovation
Working Group**

Innovative Pumped Storage Hydropower Configurations And Uses

Capabilities, Costs & Innovation Working Group
September 2021



About the International Forum on Pumped Storage Hydropower

Launched in 2020 and jointly chaired by the U.S. Department of Energy and the International Hydropower Association (IHA), the International Forum on Pumped Storage Hydropower (IFPSH) is a multi-stakeholder platform that brings together expertise from governments, the hydropower industry, financial institutions, academia and NGOs to shape and enhance the role of pumped storage hydropower (PSH) in future power systems.

The Steering Committee of the IFPSH, comprised of governments, intergovernmental organisations and multilateral development banks, established three Working Groups (WG) covering 'Policy and Market Frameworks', 'Sustainability', and 'Capabilities, Costs and Innovation' to help address the common challenges facing PSH development.

The Policy & Market Frameworks WG, led by GE Renewable Energy, developed a global position paper to identify the current market and investment barriers and opportunities for PSH development, as well as recommendations to de-risk investment. With thanks to over 20 supporting organisations, country and region-specific recommendations were developed for the U.S., the U.K., Africa, Australia, Brazil, Latin America and the Caribbean, Europe, Southeast Asia, India and China.

The Sustainability WG, led by EDF, aims to provide guidance and recommendations on mitigating adverse impacts that may occur in the development of PSH to ensure that it can best support the clean energy transition in the most sustainable way.

The Costs, Capabilities and Innovation WG, led by Voith Hydro, seeks to raise awareness on the role of PSH in addressing the needs of future power systems and deepen understanding about its potential, capabilities, costs, and innovation.

Disclaimer

The information, views, and conclusions set out in each report are entirely those of the authors and do not necessarily represent the official opinion of the International Forum on Pumped Storage Hydropower (IFPSH), its partner organisations or members of the Steering Committee. While all reasonable precautions have been taken, neither the International Forum on Pumped Storage Hydropower nor the International Hydropower Association can guarantee the accuracy of the data and information included. Neither the International Forum on Pumped Storage Hydropower nor International Hydropower Association nor any person acting on their behalf may be held responsible for the use, which may be made of the information contained therein. More information on the International Forum on Pumped Storage Hydropower is available online at <https://pumped-storage-forum.hydropower.org/>.



Acknowledgements

This report was edited by

Prof. Alexander H. Slocum, Walter M. May and A. Hazel May Professor of Mechanical Engineering at MIT;

Prof. Maha Haji, Assistant Professor of Mechanical and Systems Engineering at Cornell University; and

Dr. Klaus Krüger, Senior Expert in Plant Safety and Energy Storage Solutions at Voith Hydro.

The report benefited from extensive contributions and comments from members of the Capabilities, Costs & Innovation Working Group of the International Forum on Pumped Storage Hydropower, they include:

Alexander Arch and Klaus Öhlböck (AFRY), Alexander Jung (Voith Hydro), Alex Campbell, David Samuel, Rebecca Ellis, Samuel Law and Olivia McCue (International Hydropower Association), Arun Kumar and Akshita Gupta (Indian Institute of Technology, Roorkee), Bente Brunes, Surbhi Goyal and Zuzana Dobrotková (World Bank), BP Rao (NHPC Ltd), Cláudia Gouveia, Diogo Cordeiro and Andressa Bade (EDP Gestão da Produção de energia SA), DMR Panda (NTPC Ltd), Douglas A. Spaulding (Nelson Energy), Elena Vagnoni (EPFL), Erfaneh Sharifi, Jackson, Kathryn and Samuel Bockenbauer (US DOE), Franz Georg Pökl, Wolfgang Richter and Gerald Zenz (Graz University of Technology), Guillaume Rudelle and Jerome Brindon (GE Hydro), Hector Medina and Thomas Eldredge (Liberty University), Henry Obermeyer, Jeff Gessaman and Claudiu Iavornic (Obermeyer Hydro), Jean-Louis DROMMI (EDF Hydro Engineering Centre), Joan Leal (Oceanus Power & Water), Joana Santiago (EDP Gestão da Produção de Energia SA), João Delgado (EDP NEW R&D - Centre for New Energy Technologies), Jon Newman (Fluence), Marine Bernicot (ISL Ingénierie), Mark Cordell (Stantec), Matthew Stocks and Andrew Blakers (Australian National University), Mikael Bergmark (Pumped Hydro Storage Sweden AB), Mike McWilliams (McWilliams Energy), Miroslav Marenc (IHE Delft), P.M. Nanda (GREENKO), Paul Molnar (Hydro Tasmania), Quentin Boucher (Supergrid Institute), Quidnet Energy Inc, S M Shafiul Alam and Thomas Mosier (Idaho National Lab), Shreedhar Singh (SECI Ltd), Stettner Peter and Schwab Alexander (Andritz), Thomas Johansson (Mine Storage International AB), and Vladimir Koritarov (Argonne National Laboratory).



Introduction

Pumped storage hydropower (PSH) operates by storing electricity in the form of gravitational potential energy through pumping water from a lower to an upper reservoir (see figure 1).

First built since the end of 19th century, PSH is a mature and proven technology for long duration energy storage. It has continuously evolved to suit the needs of changing power systems, providing a suite of power system flexibility services such as inertia, frequency control, voltage regulation, and black-start capability, which are vital to support the growing shares of variable renewable energy in grid systems. However, it is often absent in discussions concerning the need and deployment of energy storage due to lack of understanding and perceived geographic limitations.

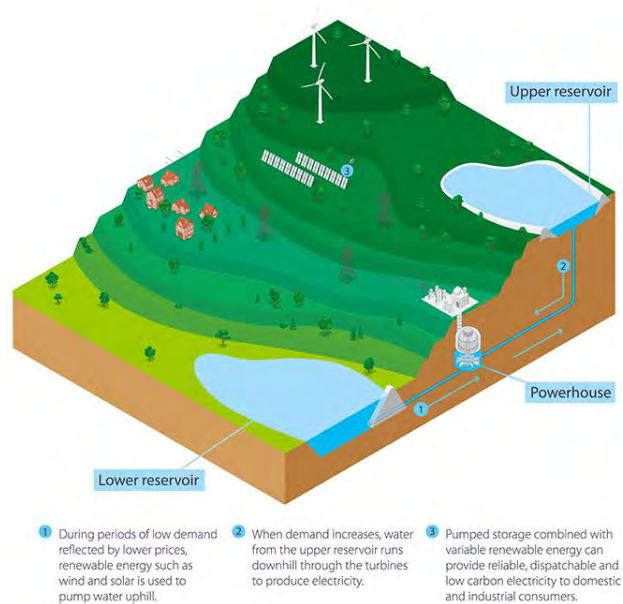

It is axiomatic that short and long term dispatchable energy storage is critical to society. In the past it was in the form of fossil fuels, and in the future it must be mostly carbon free over its whole life cycle. While in many industrial societies have already had "energy transitions" in the form of the replacement of coal by oil and gas or nuclear energy, there was only a change in the primary energy source while the system architecture remained unchanged. In these systems, energy storage did not have any important functionality, because a sufficiently high and permanently available reserve capacity was inherently provided by the fuel itself for the thermal power plants (base load capability with reliable available capacity) and because the residual load was never below zero. Energy storage was provided by nature in the primary resources of coal, gas, uranium or oil, while electricity was generated according to demand by thermal power plants beholden to the Carnot cycle, meaning that energy storage took place before electric power generation by steam turbines.

However, the production of renewable energy from wind and sun is detached from demand and it becomes necessary to store the energy after it is collected. This changes the sequence of storage and production and adds additional costs. Currently, policy makers too often assume that it will be possible to forego storage by focusing on grid expansion and the flexible control of production and use such as implied by published articles (e.g. [6], [9]) that propose compensating for the volatility of renewable energy by building controllable and highly flexible new thermal plants (e.g. gas power plants) and by promoting the use of demand side management (disconnecting consumers in the industrial and private sectors).

Here we present a viable lower carbon approach to the main challenges of energy transition relating to system architecture: The provision for sufficient flexibility when feeding in significant amounts of renewable energy (RE) and ensuring system adequacy (reliable available capacity) during periods of low production from renewable sources can be met with Pumped Storage Hydroelectric systems as the primary system for long duration and medium response time, with chemical batteries providing short term fast response.

To this end, we have called for short technology profiles to be submitted that describe new approaches to energy storage with pumped storage hydropower as a base. The goal of this report is to improve the understanding of innovative PSH technologies and to explore potential benefits and opportunities based on physics and evidence.



Each innovation profile author was encouraged to adhere to address the following topics and concerns using the following format:

- **Technology brief**
To describe the special features of the technology, its primary functions and problems address, its technology maturity, and any projects undertaken using the technology.
- **Challenges, barriers and emerging opportunities**
To discuss essential requirements and/or boundary conditions of the technology e.g., physical, geographical, legislative environment, market design; relative technical, environmental, and societal advantages over other innovations or existing practice; and answers what government or regulatory measures are needed to support its development; and discusses next steps towards adoption.
- **Cost-efficacy and feasibility**
To detail financial costs and feasibility associated with the technology; evidence and compatibility; and risks related to the adoption of the technology.
- **Potential beneficiaries and use cases**
To describe the target audience - such as the government (national/regional), system operator, utility, community; suitable use cases – e.g., countries and/or regions with a particular issue; and how the technology could best be utilized.
- **Evidence and supplementary information**
To provide references, publications, case studies and related patents; financial modeling that highlights comparisons of key indicators between base case and improved case, such as LCOS (\$/MWh), LCOW (\$/m³), efficiency (%), CAPEX reduction (%) (if applicable).

Over twenty technology briefs were submitted by a wide range of organizations from industry, academia, and government laboratories. The reviewers went through several rounds and some papers were then withdrawn as the ideas were too early for presentation in this Forum, as such, 17 profiles were included in this report. Furthermore, we have asked for detailed costing and carbon accounting analysis to be provided, to which we received a range of responses with varying levels of detail. To compare innovations, an estimated Technology Readiness Level (TRL) were added for each brief.



Table 1 - Technology Readiness Level (TRL)

Introduced by the United States National Aeronautics and Space Administration (NASA) in the 1980s, the TRL indicates the maturity of a given technology as defined in Table 1 (as defined by the United States Department of Energy).¹

Technology Readiness Level	TRL Definition
TRL 1	Basic principles observed and reported
TRL 2	Technology concept and/or application formulated
TRL 3	Analytical and experimental critical function and/or characteristic proof of concept
TRL 4	Component and/or system validation in laboratory environment
TRL 5	Laboratory scale, similar system validation in relevant environment
TRL 6	Engineering/pilot-scale, similar (prototypical) system validation in relevant environment
TRL 7	Full-scale, similar (prototypical) system demonstrated in relevant environment
TRL 8	Actual system completed and qualified through test and demonstration.
TRL 9	Actual system operated over the full range of expected conditions.

¹ https://www.energy.gov/sites/prod/files/em/Volume_I/O_SRP.pdf



Executive Summary

For the ideas that have made it through the initial peer review process, a short summary is provided here to promote discussions and help develop a path forward:

- New approaches for PSH highlighted in this report span three broad categories: furthering PSH potential (such as seawater PSH), retrofitting and upgrading PSH systems (such as utilizing abandoned mines), and developing hybrid systems (such as combined with thermal storage).
- There is emerging research on retrofitting PSH at disused mines, underground caverns, non-powered dams and conventional hydro plants, representing vast untapped PSH potential. Environmental impacts are smaller than greenfield PSH developments with the underground lower reservoir and upper reservoir constructed on an existing brownfield site.
- Location agnostic systems are made possible by modern tunnel boring machines to create underground water ways and power houses, or convert an existing abandoned mine.
- Enhanced by latest technological advancements, such as the use of variable speed pump-turbines or hydraulic short circuit, it is possible to enhance the performance and flexibility services provided by existing PSH with viable costs.
- Hybrid solutions such as PSH coupled with other energy storage technologies (e.g. batteries) and solar PV have the potential to provide a one-stop solution and enable access to revenue streams in electricity markets.
- Thermal PSH is a new concept that seeks to maximise efficiency with heat storage, and suggests that deep excavated rock when exposed to the air absorbs considerable carbon dioxide from air, reducing system lifecycle carbon footprint.
- Oceanside seawater PSH has great potential in many places around the world, especially when combined with reverse osmosis to provide freshwater with reduced costs and environmental impacts. In addition, given the large populations near coastlines, it is beneficial to use seawater as the main source for working fluid for PSH with the ocean as the lower reservoir. The system can also then readily provide freshwater by desalination where power turbine outflow dilutes brine output.
- Financing a first-of-kind technology can be challenging, and it is likely the first project will be implemented under balance sheet financing, possibly by a state-owned utility in support of major PV installations.
- To catalyse the path forward for development of traditional and new PSH systems, peer-reviewable detailed financial, environmental, and social impact factor cost accounting is needed to enable policy makers and investors to make rational decisions. Research institutions play an important role in helping to produce this analysis and peer review to ensure accuracy.
- When comparing costs to those of chemical battery systems, full life-cycle costs over the entire lifespan of the system must be considered.
- Business and policy barriers (feed in tariffs, tax breaks, levies) are as big as technology barriers in the deployment of these innovations. To incentivise the development of carbon-free energy storage systems and disincentivise the continued use of carbon-intensive fossil resources at hand, a



International Forum on Pumped Storage Hydropower
Capabilities, Costs & Innovation Working Group



Greenhouse Gas Emissions fee (GEF) could be deployed to represent the true cost of carbon emissions in all products produced domestically or imported, which would be collected to support a renewable energy research and development fund to combat global warming.

- Education is fundamental for the continuous improvement in research and development, as well as increasing awareness on the need for carbon accounting in order to avoid disastrous climate change.

An overview of the TRLs of the various innovations detailed in the following report were included in Table 2 below by the editors.



Table 2 - Summary of innovations and estimated TRL

Category	Name and short description	Estimated TRL	Author
Further PSH Potential	<u>Off-river Pumped Hydro Energy Storage</u> Off-river PSH (also known as closed loop PSH) with low water requirement and minimal impacts on natural water flows. An online global off-river PSH atlas has identified 616,000 potential storage sites around the world with a combined storage potential of 23,000 TWh, which is two orders of magnitude more than required to support large fractions of renewable electricity.	9	Australian National University
Further PSH Potential	<u>Geomechanical Pumped Storage</u> Storing energy as pressurised water in underground rock formations; Sited independently of elevated terrain; Modular (1 – 10 MW per well) and scalable durations (10+ hours) with low marginal capex (<\$10/kWh).	5	Quidnet Energy
Further PSH Potential	<u>Location Agnostic Pumped Storage</u> Freely locatable PSH system with an upper reservoir at ground surface level connected to an underground lower reservoir that can be constructed anywhere, irrespective of topography.	5	McWilliams Energy
Further PSH Potential	<u>Seawater Pumped Storage Systems</u> PSH situated at coastal sites using the sea as the lower reservoir, well suited to steep coastal areas such as isolated big islands and Small Island Developing States (SIDS).	7-8	IHE Delft
Further PSH Potential	<u>Underground Pumped Hydroelectric Storage</u> PSH with an underground reservoir excavated using tunnel boring machines (TBMs) in strong bedrock at a depth of 2500 feet, which provides opportunity for PSH in topographically challenged areas which cannot support conventional above ground PHS.	6	Nelson Energy





Category	Name and short description	Estimated TRL	Author
Retrofitting and Upgrading	Retrofitting existing hydropower reservoirs Retrofitting existing hydropower and dam facilities into at a low cost, in a short time-scale, with reduced environmental and social impacts and at minimal risk.	9	McWilliams Energy
Retrofitting and Upgrading	Retrofitting PSH on open pit mine Using existing open pit mines as lower reservoirs to reduce capital costs compared to greenfield PSH developments; Significant interest in Australia, US, and UK e.g. Eagle Mountain PSH in the US and 250 MW Kidston PSH in Australia.	8-9	Stantec
Retrofitting and Upgrading	PSH utilising underground mine Utilising abandoned underground mines as lower reservoirs. Environmental impacts are smaller than for the greenfield PSH developments because the lower reservoir is underground and the upper can be constructed on an existing brownfield site.	6-7	AFRY
Retrofitting and Upgrading	Double-fed Induction Machines in Hydraulic Short Circuit Operation – The Frades 2 Applying Double-fed Induction Machines to Hydraulic Short Circuit (HSC) for simultaneous operation in pump and turbine mode with two pump-turbine units, increasing flexibility through extending the power plant operation range.	6-7	EDP and Voith Hydro
Retrofitting and Upgrading	Hydraulic Short Circuit at High Head PSH – Grand Maison Adding Hydraulic Short Circuit for simultaneous operation of pump and turbine units to provide frequency regulation, in the case of Grand Maison, it will provide half of France's total requirement for secondary frequency control.	7	EDF Hydro Engineering Centre
Retrofitting and Upgrading	Pumped Storage operating range extension – The Alqueva Extending the operating range on pump-turbine units for a cost-effective medium-term solution to increase the flexibility of the existing fleet.	7-8	GE Hydro
Retrofitting and Upgrading	Obermeyer Pump Turbine: Cost Effective Pumped Storage Hydropower Submersible pump/turbines and generators well suited for existing hydropower sites and at dams that are not currently being used for power generation; applicable for up to about 100 MW.	3	Obermeyer Hydro



Category	Name and short description	Estimated TRL	Author
Hybrid Systems	<u>Hybrid Pumped Storage Hydropower-Battery Storage</u> Combines the long-duration storage of pumped storage hydropower (PSH) with other fast acting, shorter duration energy storage system (ESS) technologies to provide complementary capabilities and services.	6-7	Fluence, Idaho National Laboratory, Supergrid Institute, École polytechnique fédérale de Lausanne (EPFL)
Hybrid Systems	<u>Hybrid Renewable Modular Closed-Loop Scalable PSH System</u> PSH concept using bladder-type tank reservoirs to allow modular and scalable (1-10 MW) PSH easily deployable in many terrains and configurations.	3	Liberty University
Hybrid Systems	<u>Integrated Pumped Hydro Reverse Osmosis Clean Energy System (IPHROCES)</u> PSH plant uses surplus grid electricity or onsite RE generation to pump seawater into upper reservoir. Desalination plant powered by hydraulic pressure; no electricity needed.	7	Oceanus Power & Water
Hybrid Systems	<u>Solar PV hybrids</u> Coupling PSH with solar to provide dispatchable power with low costs and minimal environmental impacts, especially for smaller or weaker grids.	6-7	ISL Ingénierie, World Bank, Indian Institute of Technology Roorkee
Hybrid Systems	<u>Thermal Pumped-Storage Hydropower</u> Combines PSH with underground thermal energy storage to create closed-loop and underground 'Hot-water PSH'.	5	Graz University of Technology



Table of Contents

Acknowledgements	3
Introduction	4
Table 1 - Technology Readiness Level (TRL)	6
Executive Summary	7
Table 2 - Summary of innovations and estimated TRL	9
Further PSH Potential	14
Off-river Pumped Hydro Energy Storage	15
Geomechanical Pumped Storage	18
Location Agnostic Pumped Storage (LAPS)	20
Seawater Pumped Storage System	23
Underground Pumped Hydroelectric Storage (UPHS)	26
Retrofitting and Upgrading	29
Retrofitting existing hydropower reservoirs	30
Retrofitting PSH on open pit mine	33
PSH utilising underground mine	37
Double-fed Induction Machines in Hydraulic Short Circuit Operation – The Frades 2	41
Hydraulic Short Circuit at High Head PSH – Grand Maison	43
Pumped Storage operating range extension – The Alqueva	45
Obermeyer Pump Turbine: Cost Effective Pumped Storage Hydropower	48
Hybrid Systems	52
Hybrid Pumped Storage Hydropower-Battery Storage	53
Hybrid Renewable Modular Closed-Loop Scalable PSH System	56
Integrated Pumped Hydro Reverse Osmosis Clean Energy System (IPHROCES)	58
Solar PV hybrids	61
Thermal Pumped-Storage Hydropower	64
Appendix	67
Supplementary information - Location Agnostic Pumped Storage (LAPS):	68
Supplementary information - Seawater Pumped Storage System	71
Supplementary information - Underground Pumped Hydroelectric Storage	72
Supplementary information - Retrofitting PSH on open pit mine.....	78
Supplementary information - PSH utilising underground mine.....	81



Supplementary information - Pumped Storage operating range extension – The Alqueva.....	83
Supplementary information - Obermeyer Pump Turbine: Cost Effective Pumped Storage Hydropower.....	84
Supplementary information - Hybrid Pumped Storage Hydropower-Battery Storage.....	86
Supplementary information - Hybrid Renewable Modular Closed-Loop Scalable PSH System.....	87
Supplementary information - Integrated Pumped Hydro Reverse Osmosis Clean Energy System (IPHROCES)	90
Supplementary information - Thermal Pumped-Storage Hydropower.....	91



Further PSH Potential

In the discussion on the future growth of energy storage technologies, numerous reports have overlooked the potential of PSH with the misconception that majority of viable PSH sites with suitable geographical conditions have already been developed.

This section features a range of innovations such as off-river PSH, seawater PSH to a range of underground PSH concepts that seeks to explore the vast untapped potential of PSH in innovative configurations that would not require damming of rivers.



Off-river Pumped Hydro Energy Storage

Lead authors: Matthew Stocks and Andrew Blakers, Australian National University

Estimated Technology Readiness Level (TRL): 9

Key concept

- Off-river PSH with low water requirement and minimal impacts on natural water flows.
- An online global off-river PSH atlas has identified 616,000 potential storage sites around the world with a combined storage potential of 23,000 TWh, which is two orders of magnitude more than required to support large fractions of renewable electricity.

Technology brief

Off-river pumped hydro storage has vastly more potential sites than on-river pumped hydro. This is because most of the world's land is not near a river. A river is not required for closed-loop PHS.

An off-river PSH comprises a pair of reservoirs spaced several kilometers apart, located at different altitudes, and connected with a combination of aqueducts, pipes and tunnels. The reservoirs can be specially constructed or can utilise old mining sites or existing reservoirs. Off-river PSH utilises conventional hydroelectric technology for construction of reservoirs, tunnels, pipes, powerhouse, electromechanical equipment, control systems, switchyard and transmission.

A global survey of off-river pumped hydro energy storage was undertaken by the Australian National University². A total of 616,000 good sites around the world were found in the latitude range 60° N to 56° S.

An online global off-river PHES atlas is accessible via <http://re100.eng.anu.edu.au/global/index.php>

Each site comprises a closely spaced reservoir pair with defined energy storage potential of 2, 5, 15, 50 or 150 GWh. Protected areas and major urban sites are excluded from the reservoir siting. Each site is categorised into a cost-class (A through E) according to a cost model described below, with class A costing approximately half as much per unit of energy storage volume as class E.

Land requirements for off-river PSH are small in comparison with the solar and wind farms that the PSH supports. Water requirements are very small in comparison with water abstractions for other purposes.³

Challenges, barriers and emerging opportunities

Pumped hydro storage has an enormous growth opportunity. The global storage energy and power required in 2050-60 is about 500 TWh and 20 TW respectively, which is an order of magnitude larger than at present. Pumped hydro could win a large fraction of this opportunity.

1. Most major economies (EU, China, Japan, USA etc) are committing to reach zero emissions by 2050-60.
2. Fossil fuels cause $\frac{3}{4}$ of global emissions
3. Solar and wind constitute $\frac{3}{4}$ of global net new annual capacity additions, because they are cheaper than fossil and nuclear. Solar and wind will be the dominant methods used to drive all fossil fuels out of the global economy because their cost and annual deployment scale are much more advantageous than fossil alternatives.⁴
4. Per capita electricity consumption in advanced economies is in the range of 5-15 MWh per person per year. Complete elimination of fossil fuels from the economy entails doubling or tripling of electricity production. ⁵Thus, global electricity production may reach 20 MWh per person per year.
5. The global population is expected to reach about 10 billion in mid-century.

² <https://doi.org/10.1016/j.joule.2020.11.015>

⁴ <https://ieeexplore.ieee.org/document/8836526>

⁵ <https://doi.org/10.1016/j.energy.2020.119678>



6. When developing countries catch up to per capita energy consumption in today's advanced economies, then global electricity production of about 200,000 TWh per year will be required.
7. Assuming that electricity is produced by deployment of a combination of solar (60%), wind (30%) and other methods (10%), a total of 81 Terawatts (TW) of solar and 17 TW of wind power will be required (assuming average system capacity factors of 17% and 40% respectively). Annual deployment rates of solar and wind need to grow by a factor of 20 to eliminate fossil fuels by 2050.
8. About one day of energy storage is required, with sufficient storage power capacity to be delivered over 24 hours. Thus, required storage energy and power is 500 TWh and 20 TW respectively.
9. Major competing technologies are utility batteries, EV batteries and in-factory high-temperature thermal storage. Overnight and longer-term storage (such as PHS) will dominate storage energy but not storage power requirements.

The environmental barriers to off-river pumped hydro are much lower than conventional river based hydro reservoirs that include new dams on rivers. The schemes are not designed to capture water beyond the initial reservoir fill so there is minimal impact on natural stream flows.

Cost-efficacy and feasibility

Australia is a physically isolated global pathfinder for rapid deployment of solar and wind. It is instructive to look at what is happening in Australia. Australia is installing solar PV and wind 3-5 times faster per capita than Europe, Japan, China or the USA, and 10 times the global average. Australia is deploying Gigawatts of pumped hydro, batteries and transmission in response. There are a dozen serious PSH systems under development in Australia and two under construction (Snowy 2.0 and Kidston). None involves new dams on rivers.

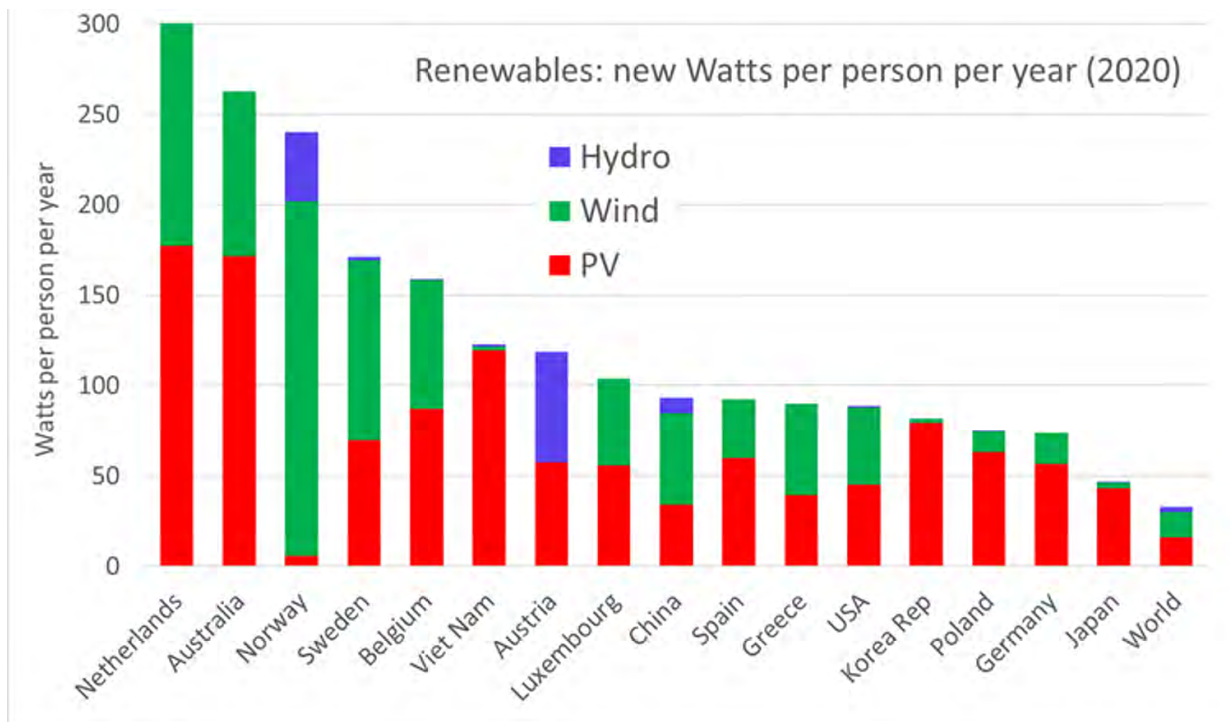

Figure A1-1: Chart showing watts of renewable energy per person per year.

Off-river closed loop pumped hydro relies on conventional technologies and therefore costs can be reasonably estimated. The global pumped hydro atlas provides ranked costings for individual sites based on the methodology described in <https://doi.org/10.1016/j.joule.2020.11.015>.

Head is a key metric for reducing cost and an important benefit for utilising off-river sites. Doubling head leads to a halving of the reservoir volume required to store a targeted quantity of energy and therefore associated costs. Power costs also reduce, but less strongly, due to the lower volumes of water flow required in the tunnels and pump/turbines. The scale of storage power and energy of the scheme also affects the



cost with larger schemes costing less per MW than smaller schemes. Site specific details such as the separation of the reservoirs and the size of the dams required also affect costs.

An A-class site in the atlas with 6 hours of storage would have a capital cost of around US\$800,000/MW while a site with 18h of storage would have a cost around US\$1,400,000.⁶

The levelised cost of storage for an A-class 6 hour storage site cycling 300 times per year (for example: paired with solar PV) would be US\$40/MWh assuming a real discount rate of 5%, in line with large scale renewable investment. Given the long project life and capital component, the LCOS is very sensitive to the discount rate with a 1% increase in discount rate leading to a 10% increase in levelised cost. Ensuring that policy frameworks minimise project risks will be important to these investments.

Potential beneficiaries & use cases

The identification of a vast off-river pumped hydro resources shows that pumped hydro can contribute significantly to the energy transition. Most regions of the world have orders of magnitude greater storage capacity than required to balance large fractions of variable renewable generation. Understanding this helps overcome a key barrier to continued deployment of variable renewables. Governments and energy system operators responsible for managing the low carbon transition of their electricity can include significant quantities of pumped hydro in their planning to manage future large volumes of low cost wind and solar.

Lack of storage is often raised as an objection to high levels of solar & wind. PSH is often dismissed as an option "because of insufficient rivers to dam". These objections fail in the light of the vast off-river PSH opportunity.

Facts on the ground in Australia (which is the global pathfinder for high levels of PV and wind) bear out the thesis that non-dam closed-loop hydro will provide most of the overnight and longer-term storage in the energy transition.

⁶ A detailed costs breakdown could be found at <https://doi.org/10.1016/j.joule.2020.11.015>. Further discussion on costs could be found at <https://reneweconomy.com.au/off-river-pumped-hydro-could-provide-lower-costs-for-energy-storage-31629/>



Geomechanical Pumped Storage

Lead author: Quidnet Energy Inc

Estimated Technology Readiness Level (TRL): 5

Key concept

- Storing energy as pressurised water in underground rock formations sited independently of terrain
- Modular (1 – 10 MW per well) and scalable durations (10+ hours) with low marginal capex (<\$10/kWh)

Technology Brief

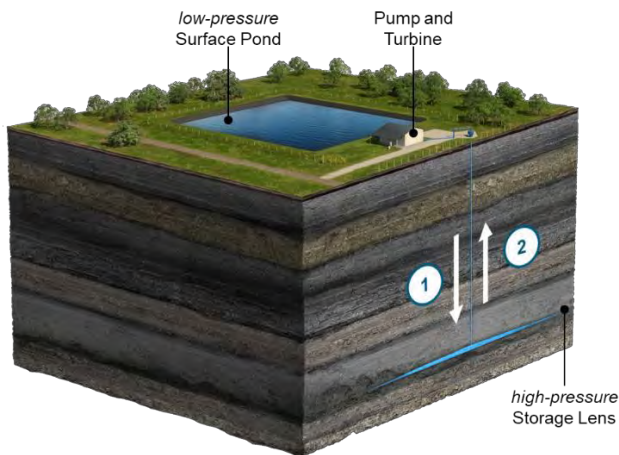

- ① **Charge.** Water pumped down the well into high-pressure storage lens
- ② **Discharge.** High-pressure water flows up the well to drive a turbine

Figure A2-1: Illustration of geomechanical Pumped Storage

Geomechanical Pumped Storage (“GPS”) leverages rock geomechanics to store energy as pressurized water underground using off-peak energy which is then released to generate power to meet peak demand requirements.

The entire module is built on conventional drilling technology and off-the-shelf hydropower equipment. Facilities operate with closed-loop water systems, designed for conservation against evaporative loss. The energy-storing rock bodies are non-hydrocarbon bearing and can be found abundantly throughout the world, intersecting with major electricity transmission and distribution hubs.

Quidnet pioneered the GPS solution and has developed projects across North America, with the support of major government agencies, including the Water Power Technology Office at the US Department of Energy.

Challenges, barriers and emerging opportunities

The Geomechanical Pumped Storage solution has the following key attributes:

- Modular (1 – 10 MW per well) and aggregated to a single point of interconnection
- Scalable durations (10+ hours) with low marginal capex (<\$10/kWh)
- Lean construction profile with <50% capex of traditional pumped hydro
- Accelerated permitting of facility construction and operations
- Sited independently of elevated terrain with TWh-scale resource across the US alone



Figure A2-2: Examples of development in the US

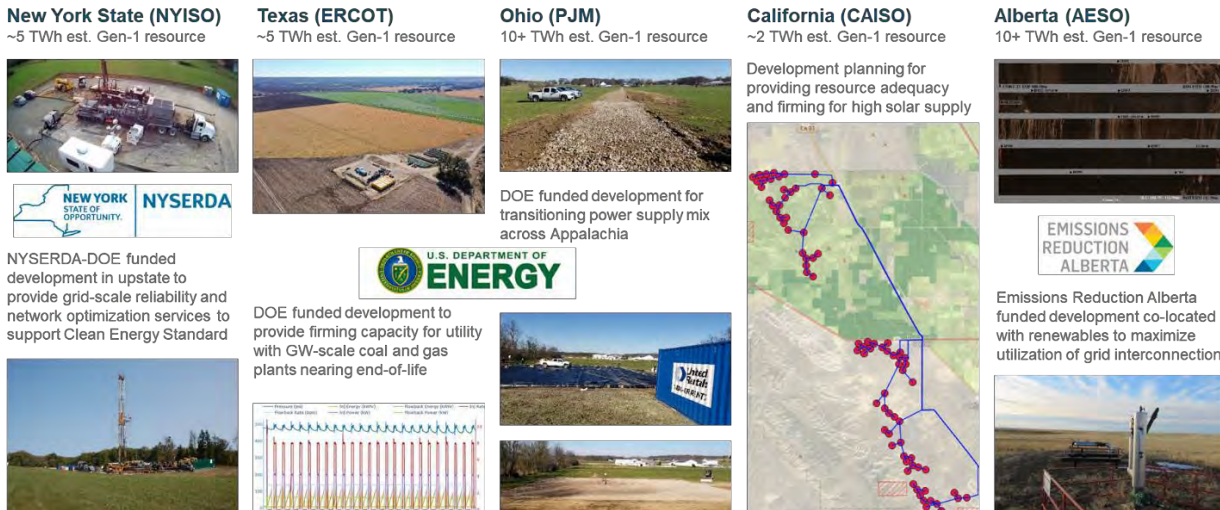

Cost-efficacy and feasibility

Geomechanical Pumped Storage is assembled from a very lean bill-of-materials, achieving a capital expenditure that is 50-85% less than alternatives. In addition to capex, GPS has other structural and deployment advantages compared to alternatives, including being able to draw on a mature machinery and highly scalable deployment supply chain, lack of need for exotic material sourcing, and safe, low-cost decommissioning.

While the subsurface storage of pressurized water in a lens between impermeable rock layers is novel, the drilling and well construction technologies involved are fully commercial and the pumps and turbines are standard hydropower industry equipment. Because the subsurface geology needed for a storage lens is ubiquitous and the surface pond size is modest, Quidnet Energy’s approach overcomes the siting limitations of conventional pumped hydro energy storage.

Although geomechanical pumped storage technology stands to expand hydro pump and turbine-based storage into areas without rivers and dams, finding suitable geology for the underground storage may limit the application of this technology in some areas. Geomechanical pumped storage requires a certain pressure profile to operate effectively and impermeable rock layers above and below the storage lens to prevent leakage.

Quidnet’s technical development plans for the next year and beyond are focused on generating field operational data to refine downhole execution protocols for deploying subsurface storage lenses across a wide array of geologies. Quidnet will be refining protocols for ensuring long-term operating performance and optimizing the configuration and unit costs of the surface hydropower conversion facility.

Potential beneficiaries & use cases

Quidnet’s target market is comprised primarily of utilities, renewable developers, together constituting the utility-scale market for energy storage in the US.

For utilities, Quidnet ensures that they can reliably match customer load with low-cost grid electricity, optimize the power flow on the grid, and meet regulatory requirements for supply resource adequacy.

For renewable developers, Quidnet overcomes export limitations posed by transmission constraints, reduces the risk of congestion-based curtailments, and improves the energy value of the generation profile.

For displaced oil and gas industry workers, Quidnet offers the opportunity to participate in the green energy transition by repurposing their downhole knowledge and skillsets into the expanding energy storage sector.



Location Agnostic Pumped Storage (LAPS)

Lead author: Mike McWilliams, McWilliams Energy

Estimated Technology Readiness Level (TRL): 5

Key concept

- Freely locatable PSH system with an upper reservoir at ground surface level connected to an underground lower reservoir that can be constructed anywhere, irrespective of topography.

Technology brief

A persistent criticism of pumped storage is its requirement for specific topography, as PSH potential sites are not evenly distributed around the world, and some grid services require pumped storage to be at specific locations. Hence there is a need for pumped storage that can be constructed anywhere – Location Agnostic Pumped Storage or LAPS. This technology was conceived by McWilliams Energy⁷ with support from Mott MacDonald⁸.

Pumped storage requires a hydraulic head between the upper and lower reservoir, and since LAPS must work on flat ground, the upper reservoir must be on the surface and the lower reservoir must be underground. Furthermore, since the volume of the reservoirs is inversely proportional to the head, locating the reservoir deep underground is advantageous.

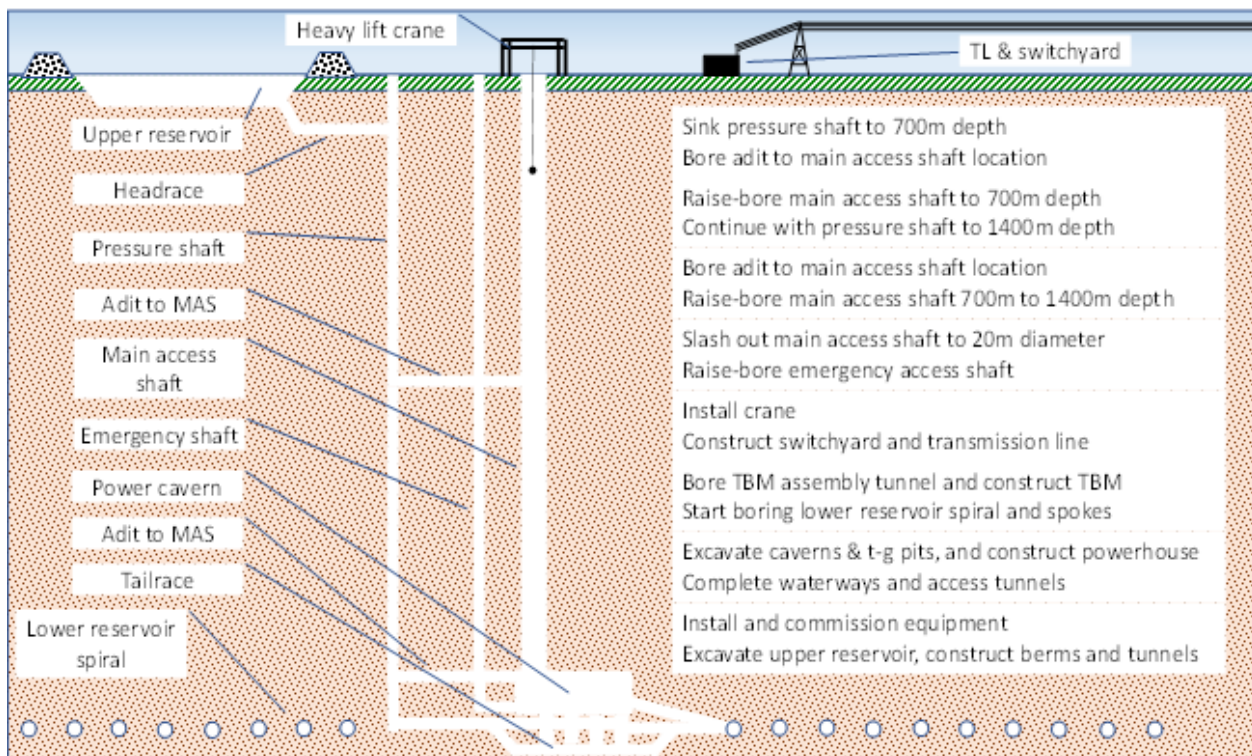

The characteristics of a basic LAPS scheme are as follows:

- **Depth:** For economic sizes of waterways, t-g units and reservoirs, the head should exceed 1000 m, but lie within the range of proven technology. The current concept is based on 1400 m depth.

⁷ [McWilliams Energy \(mcw-e.com\)](http://mcw-e.com)

⁸ [Global engineering, management and development consultants - Mott MacDonald](#)



- **Capacity:** for economic development, this technology is only suited to grid-scale PSP, ideally in excess of 500 MW. The basic scheme has installed capacity of 1000 MW using 4 units of 250 MW.
- **Technology:** for PSH in excess of 700 m revisable pump-turbines are not suitable, and hence Pelton turbine based ternary units, with separate pumps and turbines on a common shaft, are adopted. Although more expensive, it is possible to optimise the pumps and turbines separately to maximise efficiency. As the pump and motor rotate in the same direction, rapid transition between pumping and generating modes is possible. The inclusion of a hydraulic short-circuit enables pumping and generating at the same time, giving almost seamless variation in pumping output (i.e. ability to absorb oversupply).
- **Ancillary services:** a full range of typical PSH ancillary services can be provided. Incorporation of a short-duration battery, e.g. a 1000 MW / 167 MWh Li-ion facility would provide an even greater range of services, including mechanical inertia from the PSP, and virtual inertia and power injection within 0.2 seconds from the battery (refer battery hybrid technology profile for further details).
- **Flexibility:** The plant can be configured to suit the specific requirements of the grid. Individual units have equal pumping and generating capacity by virtue of their common motor/generator, but additional pumps or turbines can be added, depending on which is needed most.
- **Reservoir elevation:** the upper reservoir is located at the ground surface, retained by bunds using spoil from the underground works. Since Pelton units are used, these must discharge above the free water surface of the lower reservoir. Also, the pumps must be submerged below the lowest water level of the lower reservoir. Hence the operating range of the reservoir must be small, requiring a shallow lower reservoir.
- **Method of construction:** Sinking the initial shaft to 1400 metres would traditionally be expensive, time consuming and risky. The Shaft Boring Roadheader⁹ developed by Herrenknecht enables shafts to be bored quickly and safely to depths exceeding 1500m. Once the first shaft is bored, the remaining shafts can be raise-bored in two 700 metre stages. A TBM is the lowest cost option to construct the lower reservoir. This is lowered down the main shaft and assembled at 1400 m depth in an assembly cavern. The lower reservoir is bored in a spiral around the pressure shaft, with radial adits to reduce the spoil transport distance, and also improve the hydraulics.
- **Water availability:** The water requirement for a basic scheme with 1000 MW / 8000 MWh at 1400m depth is around 2.5 mcm. The surface reservoir will be lined and covered to prevent evaporation and seepage. In arid regions desalinated water can be used, which only adds around 0.5% to the capital cost.
- **Land requirements:** the land required is relatively small: the basic 1000 MW / 8000 MWh scheme has a surface footprint of around 20 ha. For comparison, this is the land requirement of a typical 10 MW PV project.
- **Environmental and social impacts:** compared with conventional PSP, LAPS has minimal environmental and social impacts. Since it does not require specific topography, it can be located to avoid sensitive areas; the water requirement is minimal, and it can be provided by desalinating seawater; the surface footprint is small relative to the benefit of the facility; and with virtually all of the works underground, there is limited visual intrusion.

Challenges, barriers and emerging opportunities

Although each component of LAPS has been constructed previously, they have not all been incorporated in a single project. Appropriate contractors and equipment suppliers have been consulted, and all are confident that the LAPS technology can be implemented with little new development.

⁹ [Shaft Boring Roadheader \(SBR\) - Herrenknecht AG](#)



As with any underground project, LAPS carries construction risk. Coring at the location of the power cavern would be carried out to investigate the geology before committing to construction. With conventional linear tunnelling it is difficult to investigate the alignment, and there is continual risk of tunnelling into unknown ground. With LAPS the drilling is in a spiral with radial admits, so that tunnelling conditions ahead of the face are known.

Financing a first of kind technology can be challenging, and it is likely the first project will be implemented under balance sheet financing, possibly by a state-owned utility in support of major PV installations.

Cost-efficacy and feasibility

An Association for the Advancement of Cost Engineering (AACE) class 5 estimate for a LAPS scheme at 1400 m depth, with 1000 MW installed capacity and 8000 MWh of energy storage indicates an EPC price of USD 1.7 bn and total development cost of USD 2.2 bn (2019 prices). This implies a specific cost of USD 2200 / kW and a cost of storage of USD 275 / kWh, which is comparable with conventional PSH at a good site. The marginal cost of storage (cost of increasing above 8000 MWh) is relatively high for pumped storage at USD 175 / kWh.

Unlike other pumped-storage and conventional hydropower, LAPS is a modular system, and schemes with identical characteristics can be replicated. The cost of follow-on schemes would be lower, and a high level of cost predictability is expected.

The estimated construction period is 4.5 years from contract award. The critical path runs through shaft sinking, powerhouse construction, equipment installation and commissioning.

Potential beneficiaries & use cases

A pumped storage scheme such as LAPS will be used to provide stability and security services to the power grid. Ideally it will be specified, procured and controlled by the Electricity System Operator (ESO). A financing solution such as FELT¹⁰ (Finance, Engineer, Lease and Transfer) is ideal, enabling specification by the ESO; it would then be constructed by a contractor/developer using commercial finance, and leased to the ESO for a pre-defined term, before being transferred to public ownership.

The following supplementary information can be found in Appendix:

- A. Characteristics
- B. Schematic and construction sequence
- C. Layout
- D. Construction schedule
- E. Class 5 cost estimate

¹⁰ [MCWe FELT \(mcw-e.com\)](http://mcw-e.com)



Seawater Pumped Storage System

Lead author: Miroslav Marenc, IHE Delft, Delft, The Netherlands

Estimated Technology Readiness Level (TRL): 8

Key concept

- PSH situated at coastal sites using the sea as the lower reservoir
- Well suited to steep coastal areas such as isolated big islands and Small Island Developing States (SIDS)

Technology brief

There are sites where topography and geology favour the construction of pumped storage hydropower projects but the unavailability of a source of freshwater makes them unfeasible. Seawater can be an interesting option and could be used as a source if the location is near the coast. Increased demand for energy and restriction on greenhouse gas emissions shift electrical energy production in unreliable and unpredictable renewables like wind and solar. In areas where freshwater is rare or high evaporation rates are expected, use of saltwater instead of freshwater is an attractive option.

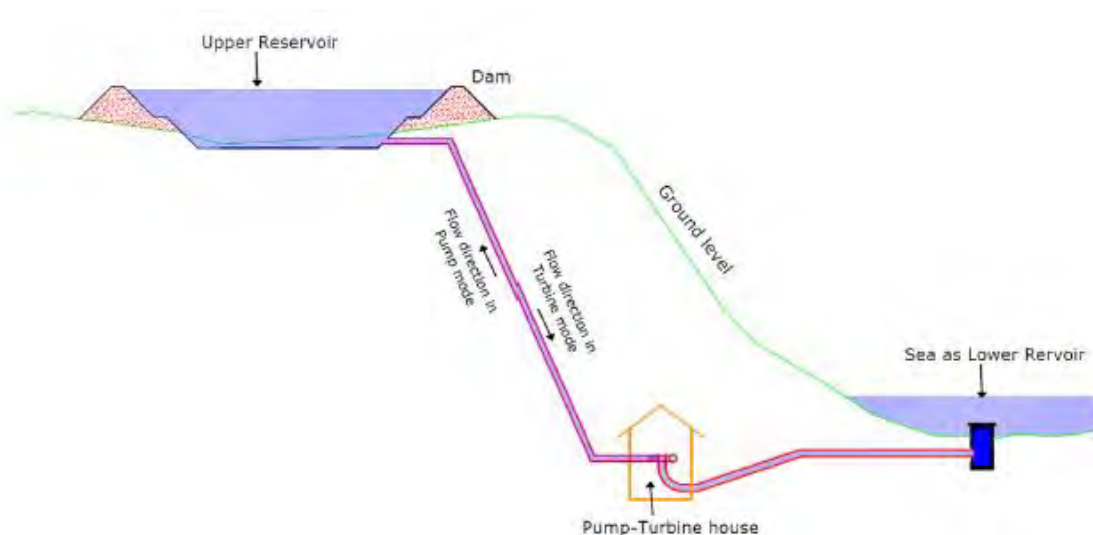

Figure A4-1: Typical sketch of seawater pumped storage system

Cliffy coast with upper reservoir locations near the coast could be an attractive solution for such countries and especially for the Small Island Developing States (SIDS). The use of saltwater is associated with several challenges that have to be carefully addressed and are mandatory for a successful project. Solving these problems is possible and it is shown by the tidal power plants that serve in the same medium and have similar problems, but successful tidal plants show that this problem could be solved in a technical and economically acceptable way. The saltwater pump storage power plant has the same setup and the same characteristics as standard freshwater pumped storage, except that the possible problems and challenges caused by saltwater have to be addressed and solved sustainably.

The first seawater pump storage project was constructed in Okinawa Island of Japan. The project was in operation for 14 years from 1999 to 2013 and was developed for research purposes. Up today this is the only operational saltwater pump storage plant. Several projects are in development, reaching the construction level, such as Espejo de Trapaca in Chile.



IHE Delft developed a method for detecting the potential sites for pumped storage powerplant with the sea as a lower reservoir¹¹. The GIS-based method detects the possible sites in the coastal area and calculates the main parameters of the plant.

Additional to the classical pumped storage systems with high head European Union Horizon 2020 research project ALPHEUS (project number 883553) works on the development of reversible pump/turbine technology and adjacent civil structures needed to make pumped hydro storage economically viable in shallow seas and coastal environments with flat topography.

Challenges, barriers and emerging opportunities

Implementation of saltwater pump storage systems is limited on the cliffy topography of the coast. Steep coast enables higher head difference on relatively short horizontal distance and reduces the power waterway costs, making the solution more attractive. Saltwater pumped storage challenges are technological, environmental and economic. Reservoir tightening, corrosion problems due to seawater and construction difficulty in the sea are major technical issues while, saltwater infiltration/dispersion, destruction of marine life and marine biofouling are environmental issues. Also, for small pump storage projects, the construction cost must be set in relation to other storage possibilities, where battery storage systems might be also an attractive solution. The technical, ecological and financial challenges are solvable and existing solutions could be implemented.

Especially in the case of isolated islands or SIDS dealing with isolated electrical grids and requirements for carbon-neutral renewable energy makes use of pumped storage plants indispensable for the integration of unpredictable wind and solar energy. The definition of the power and energy capacity is dependent on the grid regulatory needs and the energy profile of the grid. Pumped storage systems with their high capacity are an interesting solution for carbon-free isolated grids.

The specific requirements to the saltwater pumped storage like a tight reservoir which will omit any saltwater leakage in the underground causing salinization of the groundwater could be solved by a double-layered reservoir tightening system. The corrosion problems could be solved by the use of glass fiber reinforced (GFR) plastic pipes and using special corrosion-resistant steel for turbines and parts in contact with water. The inlet/outlet structure situated in the sea represents a special challenge in construction but also environmentally. Steep cost makes the construction of the inlet/outlet structure in sea challenging and sea piercing as the construction method is one possibility as also invert siphons for smaller plants with lower discharge. Outflow and especially inflow of seawater in the system is an ecological issue that must be solved together and in harmony with local environmental requirements and concerns. Solution with low water velocities is a suitable and most applicable solution that has to be a compromise economically and environmentally.

Cost-efficacy and feasibility

Pump storage system is often used in a well-developed electrical grid system, where a difference in the price of peak and base energy in the market defines the pump storage necessity and validity. In the small electrical grid system like in most of the SIDS, there is no daily energy price variation and the necessity of the storage system could only be validated by an imbalance in surplus and deficit of energy. In such systems, the cost of storage and grid regulation is included the price of the energy and is considered by the grid operator. Pump storage system helps to determine the cost of energy and it also gives the possibility for the ancillary services which have been seen as an opportunity. Also, the pump storage system with other energy storage systems helps to reduce carbon footprint.

¹¹ Pradhan, A.; Marence, M.; Franca M.J.: The adaptation of seawater pump storage hydropower system increases the share of renewable energy production in Small Islands Developing States. Renewable Energy. Available at <https://www.sciencedirect.com/science/article/pii/S096014812100834X?dgcid=author>



Potential beneficiaries & use cases

Saltwater pumped storage is a technology attractive to coastal areas with steep mountains nearby. The system is additionally interesting for isolated grids like the SIDS and other big but isolated islands. In most of these countries, the national energy utility is responsible for the energy supply and also grid stability, but in some cases, seawater pumped storage systems could be interesting for other investors. The pumped storage hydropower is not producing energy and thus the benefit is generated by the spread in the energy price between peak and baseload. For private investment, an existing tariff system distinguishing between peak and baseload is essential for private investment.

[A case study for the island of Curacao is available in Appendix.](#)



Underground Pumped Hydroelectric Storage (UPHS)

Lead author: Douglas A. Spaulding, Nelson Energy

Estimated Technology Readiness Level (TRL): 6

Key concept

- PSH with an underground reservoir excavated using tunnel boring machines (TBMs) in strong bedrock at a depth of 2500 feet, which provides opportunity for PSH in topographically challenged areas.

Technology brief

The development of UPHS projects can allow for wider use of this best-proven approach to utility-scale energy storage in areas which are topographically challenged for the economic development of conventional PSH facilities.

The concept of UPHS has been investigated at projects sites since the 1970s and most recently was proposed by John Douglas as an "Aquabank" in 2010.^{12,13} All previous project concepts, including Aquabank, used traditional mining techniques for excavation of a lower reservoir. As described below, the use of Tunnel Boring Machines (TBMs) for excavation can dramatically reduce the cost of UPHS by 50% and make UPHS competitive with conventional PSH projects.¹⁴

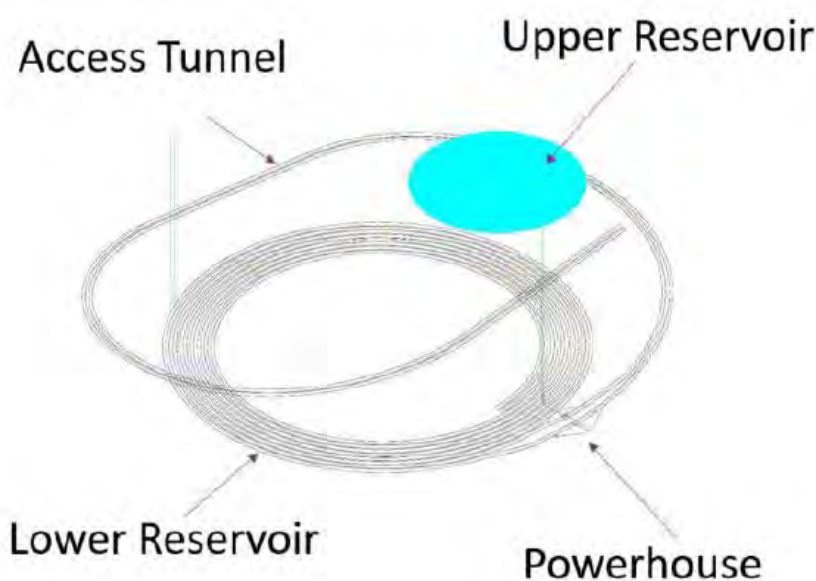

Figure A5-1: 3D view of UPHS system

The concept of UPHS minimizes cost by maximizing the operating head using an underground reservoir excavated at a depth of 2500 ft. As shown in Figure , UPHS requires a spiral ramp at a grade of 12 to 15% to be excavated to provide access to the lower reservoir. The bedrock excavated to form the lower reservoir and powerhouse (Figure 3 in Appendix) can be brought to the surface using trucks (Figure 2 in Appendix) and can be used to construct a circular rockfill embankment to form the upper reservoir (Figure 4 in Appendix). The results of

recent studies by Nelson Energy (Appendix II) demonstrate that the energy storage cost of UPHS (\$/kW-hr) is less than storage with batteries for energy storage periods greater than 8 hours. Further, a UPHS facility can be constructed as a closed loop project situated close to existing transmission facilities which minimizes environmental impacts.

¹² Underground Pumped Hydroelectric Storage, R.D.A.IIen, T. J. Doherty, L. D. Kannberg, Battelle, July 1984 Prepared for the U.S. Department of Energy under Contract DE-AC06-76RLO 1830

¹³ <https://www.waterpowermagazine.com/features/featureinvestigating-aquabank/>

¹⁴ <https://drive.google.com/file/d/1UX95vc5To8r5UYIPEpFB52PWzPSKyh7q/view?usp=sharing>



Challenges, barriers and emerging opportunities

Although the concept of underground pumped storage has been evaluated for over 50 years, no UPHS project has been constructed to date. The barriers to development largely center on concerns related to geotechnical and cost uncertainty. The development of reliable underground excavation techniques utilising TBM's over the last 70 years has decreased the cost and the uncertainties associated with the major UHPS cost component, excavation.

The concept of UPHS is most viable in areas which do not have the topography to support conventional PSH. The criteria for siting a UPHS facility requires identifying locations which have strong bedrock close to the ground surface, proximity to high-voltage transmission facilities and a water source for initial reservoir filling and periodic makeup water additions. The seismicity of a proposed area also needs to be evaluated to avoid concerns regarding project loadings creating triggering events for earthquakes.

The implementation of UPHS will provide a means to achieve long term (8 hours+) energy storage of intermittent renewable generation. The UPHS system provides a long-life system with an operational life of well over 50 years. The configuration of a given UPHS facility can be designed to provide any amount of generating capacity and energy storage needed by the existing grid system. It should be noted that the cost for increased amounts of energy storage of a UPHS system decreases on a \$/kW-hr basis due to the large initial fixed cost procuring the TBM's and constructing the access ramp to the lower reservoir. As a hydraulic generating/pumping system, a UPHS development can provide the full range of ancillary services required to support variable renewable energy sources.

Since the UPHS project consists of a closed system which does not impact an existing body of water, the project is distinctly different than conventional hydropower or open system PSH projects which can involve significant impacts to water quality and fisheries.

The concept of UPSH has been presented to several utilities but there appears to be a great reluctance to undertake a project concept that involves long-term development and a large capital investment. Future activities include identifying potential sites and utility partners which could benefit from the development of UPSH. Another alternative would be to obtain grant funding to conduct prefeasibility or feasibility studies on specific sites to support specific grid requirements. These options will be pursued in the future.

Cost-efficacy and feasibility

To provide the basis for a comparative cost estimate for energy storage utilising UPSH versus batteries and other storage techniques, a prefeasibility design and cost estimate was developed by Golder Associates and AECOM for a 666 MW project with 12 hours of storage located near Granite Falls in southwestern Minnesota. Comparative cost estimates were developed utilising both conventional drill and blast mining techniques to excavate the lower reservoir and employing TBM's to conduct the excavation. The results (\$2019) are provided below and provide both direct construction costs with a 25% contingency and estimated total project costs including financing interest and other owner costs. A more detailed breakdown of costs is provided in Appendix III. These results indicate that UPSH is more than competitive with the multiple (3-4 hour) batteries sets required to provide 12 hours of energy storage.

Energy Storage Method	Direct Cost \$/kW	Total Cost \$/kW	12hr. Storage \$/kWh
Lithium –Ion Batteries	-----	\$1876*x3= \$5628	\$469*
UPHS – Drill & Blast	\$3,000	\$4,070	\$339
UPHS – TBM	\$1,885	\$2,640	\$220

* Source PNNL Study July 2019



To gain a comparison of the cost of UPHS with conventional aboveground pumped storage, the published cost for new conventional pumped storage projects currently under development in the United States were tabulated as shown below. The focus of the comparison was the cost of energy storage on a \$/kW- hr basis. It may be noted that the storage cost for the UPHS (Granite Falls) project fell into the mid-range of conventional pumped storage projects currently under development. It is also apparent that for long duration pumped storage, UPHS is a much more economical alternative than multiple lithium-ion batteries.

<u>Project</u>	<u>Size (MW)</u>	<u>Cost (\$/kW)</u>	<u>Energy Storage Hours</u>	<u>Storage Cost (\$/kW-hr)</u>
Swan Lake	393.3	1988	9.0	220
Eagle Mountain	1300	1920	10	192
Tazewell	850	2350	10	235
Goldendale	1200	2363	12.3	192
Granite Falls	666	2640	12	220*
Lithium Batteries		5628*	12	469

* Three batteries

*Cost /kW-hr. for 12 hours, cost will decrease with increasing amount of storage due the high fixed costs associated with the acquisition of the TBMs and the construction of the access ramp.

The major risks associated with the development of UPHS relate to the unknowns associated with a type of construction configuration at great depths. The feasibility evaluation for a specific project will require costly subsurface exploration at depth to evaluate stress conditions at depth and to verify the strength of the rock at depth.

Potential beneficiaries & use cases

The concept of UPHS can provide the opportunity for long duration energy storage to areas which do not have the topography to support conventional pump storage.

[Supplementary information can be found in Appendix.](#)



Retrofitting and Upgrading

Retrofitting and upgrading existing infrastructure could often reduce costs and environmental impacts compared with greenfield development.

The following profiles present a range of solutions for utilising existing brownfield sites including existing hydropower and pumped storage facilities, non-powered dams, as well as open pit mines and underground mines.



Retrofitting existing hydropower reservoirs

Lead author: Mike McWilliams, McWilliams Energy
Contributors: Paul Molnar, Hydro Tasmania

Estimated Technology Readiness Level (TRL): 9

Key concept

- Retrofitting existing hydropower and dam facilities into at a low cost, in a short time-scale, with reduced environmental and social impacts and at minimal risk.

Technology brief

This technology covers the conversion of existing hydropower and dam facilities into pumped storage schemes by means of:

- Linking existing reservoirs
- Adding pump-back plant to existing hydropower projects
- Installing reversible pump-turbine units
- Using all, or part of existing reservoirs or natural lakes as upper or lower ponds.

Operation of existing hydropower projects, possibly modified or re-purposed, to act as virtual pumped storage is also considered.

The aim when retrofitting is to create a new pumped storage facility at a low cost, in a short time-scale, with reduced environmental and social impacts and at minimal risk. This is achieved by using *existing* infrastructure which would otherwise need to be constructed for a new PSH system, thereby reducing acquisition of new land and environmental and social impacts. This can include existing dams, waterways, powerhouses, control rooms, access roads, switchyards, transmission and other scheme components. There can also be savings on support infrastructure such as offices, workshops, stores and operator's housing, as well as maintenance equipment and personnel.

This has the potential for significant savings in construction and operation cost compared with a scheme where all of these facilities must be provided; it also can significantly reduce the time and effort required to obtain planning permission, licences and environmental permits, which act as impediments to development of new pumped storage, although the changed mode of operation still requires permitting.

Practically pumped storage from retrofitting may be constrained by the configuration and characteristics of the existing facilities. However, there can be additional benefits: for example, linking two existing reservoirs can provide massive energy storage, such as the 350 GWh at Snowy 2.0, which might not be justified as a new scheme. Retrofitting can facilitate development of seasonal pumped storage on large existing reservoirs in an economic manner, with minimal environmental and social impacts.

The technology used when retrofitting pumped storage is relatively mature: well-tried and tested components may be deployed, although the opportunity would normally be taken to install the latest technology that provides optimum benefits to the system and/or maximum financial returns.

The most prominent example of retrofitting currently being implemented is Snowy 2.0 in Australia¹⁵. Two existing reservoirs in the Snowy Mountains system are being linked with 27 km of tunnels and an underground powerhouse to create a 2000 MW pumped storage scheme with 175 hours of storage.

Also in Australia, Hydro Tasmania has been investigating its portfolio of hydropower assets, considering all of the options for retrofitting, under its Battery of the Nation programme¹⁶, including linking existing

¹⁵ [2017 Feasibility Study Chapters - Snowy Hydro](#)

¹⁶ [Battery of the Nation \(hydro.com.au\)](#)



reservoirs, using existing reservoirs as upper or lower storages and adding pump back plant to existing hydropower projects. A study has identified several cost competitive opportunities to retrofit existing hydro, and a preferred project for first development priority has been selected which would add 750MW of PSH capacity to the Tasmanian hydro system.

Frades I and II pumped storage schemes in Portugal¹⁷ make use of the 420 m head difference between Venda Nova and Salamonde reservoirs which were created in the 1950s and 1960s, providing nearly 1000 MW of pumped storage capacity. Alqueva II PSP¹⁸ added some 260 MW of reversible pump-turbines to an existing 260 MW hydro scheme; In Switzerland Limmern PSP¹⁹ uses the existing Mutt and Limmern hydropower reservoirs; Tehri PSP²⁰ in India adds 1000 MW of pumped storage between Tehri and Koteshwar reservoirs.

Retrofitting pumped storage has been used in a variety of other locations, and is under consideration in many more, ranging from the Philippines and Sri Lanka in Asia to the Americas.

Challenges, barriers and emerging opportunities

Among the situations where retrofitting may be considered are:

- **Linking existing reservoirs:** where two existing reservoirs are available in close proximity with significant elevation difference, ideally exceeding 300 metres, a pumped storage scheme may be installed. Hydropower and irrigation cascades may be ideal, although irrigation requirements can restrict the flexibility of operation. Irrigation reservoirs are often drawn down to very low levels, which may not be compatible with the operation of pumped storage plant.
- **Adding pump-back plant to existing hydropower projects:** at some existing hydropower schemes it may be possible to install a stand-alone pump to return water from the tailrace to the reservoir. The existing hydropower units may be retained, or else expanded to increase the generation capacity. Pump-back typically requires a dam downstream of the tailrace to create a pumping pond. This may anyway be desirable to re-regulate the flow and attenuate surges downstream.
- A variant of pump-back uses water pumped from an adjacent catchment, and it may be possible to gain energy if the pumping head is less than the generation head.
- **Installing reversible pump-turbine units:** in some circumstances it may be possible to replace existing Francis units with reversible units. Care is needed with the turbine submergence and hydraulic transients, the requirements for which tend to be more onerous for pump-turbines than conventional units.
- **Using all, or part of existing reservoirs or lake as upper or lower ponds:** examples of pumped storage added to existing lakes include 1872 MW Luddington on Lake Michigan in USA and 1016 MW Delio (Roncovalgrande) on Lake Maggiore in Italy. In Scotland SSE plans a 1500 MW, 30 GWh PSH on Loch Lochy²¹. In Sri Lanka there are proposals to use reservoirs of the Mahaweli Cascade as lower reservoirs for pumped storage, and all of Hydro Tasmania's candidate options use man-made reservoirs.
- **Virtual pumped storage:** the flexibility of storage hydro can be used to provide some of the attributes of pumped storage, by retaining water to be used to cover periods of peak demand or low renewables output. Norway's hydropower has been promoted to provide a Green Battery for Europe²², and this concept also forms part of Tasmania's Battery of the Nation program.

¹⁷ [Award-Winning Pumped-Storage Hydro Facility a Modern Marvel \(powermag.com\)](http://powermag.com)

¹⁸ [Alqueva II Pumped Storage Hydropower Plant, Alqueva, Portugal \(powermag.com\)](http://powermag.com)

¹⁹ [Limmern pumped storage power plant \(axpo.com\)](http://axpo.com)

²⁰ [TEHRI PUMPED STORAGE PLANT | THDC India Ltd.](http://THDC India Ltd.)

²¹ [Coire Glas | SSE Renewables](http://SSE Renewables)

²² [Pumped hydropower the green battery - Industry Europe](http://Industry Europe)



Cost-efficacy and feasibility

Costs savings from retrofitting arise in a number of areas such as construction, operation, developer's costs, environmental and social mitigation, planning and permitting and corporate organisation. If there is existing revenue and an asset for security, the cost of finance may be lower compared with non-recourse finance for a new scheme. Also, depending on the nature of the works required, the risk of delay and cost overrun may be lower than building a new project.

Retrofitting pumped storage can result in extremely low energy storage costs: the contract price for Snowy 2.0 of USD 3.6 billion implies a cost of just over USD 10 per kWh. This compares very favourably with the energy storage cost of Australia's largest battery storage at Hornsdale, of around USD 580 / kWh²³.

Potential beneficiaries & use cases

Retrofitting pumped storage should be considered as an option when refurbishing and upgrading existing hydropower plants. It should also be considered when seeking locations for new pumped storage schemes, as an option to reduce costs and minimise environmental and social impacts. It can also be used to re-purpose existing hydropower to better-suit the requirements of future low-carbon power systems.

Pump-back and installation of reversible units is likely to be most beneficial for daily pumped storage, due to the typical limitations of storage capacity of tailwater ponds. However this can suit the demands for time-shifting variable renewables, especially solar PV.

Longer term storage, such as 20-hours at SSE's proposed Coire Glas scheme in Scotland and Hydro Tasmania's Lake Cethana scheme in Australia, may be achieved when using an existing lower reservoir, if a site for a suitably large upper reservoir is available.

Seasonal storage is most likely to be achieved by linking two large reservoirs, as in the case of Snowy 2.0, providing insurance against future periods of low wind and solar generation. However the requirements for other uses, such as irrigation, need to be confirmed to ensure there is flexibility to allow long-term water retention in the upper reservoir. Virtual pumped storage, such as that proposed for Europe in Norway and for Australia in Tasmania, can provide the equivalent of seasonal pumped storage.

²³ [Tesla battery cost revealed two years after SA blackout - ABC News](#)



Retrofitting PSH on open pit mine

Lead author: Mark Cordell, Stantec

Estimated Technology Readiness Level (TRL): 8-9

Key concept

- Using existing open pit mines as lower reservoirs to reduce capital costs compared to greenfield PSH developments
- Significant interest in Australia, US, and UK e.g. Eagle Mountain PSH in the US and 250 MW Kidston PSH in Australia.

Technology brief

The opportunity to utilise open pit mine infrastructure post mine closure for the development of pumped storage hydro is not a new concept, but one that has not been exploited to date. The notable exception is the 1,728 MW Dinorwig Pumped Storage Scheme in North Wales (UK)²⁴, which was fully commissioned in 1984. The station is a prime example of an abandoned slate quarry being utilized to develop a pumped storage generation facility. Transforming an existing open mine pit into one of the storage reservoirs has the attraction of not requiring the construction of a new dam. However, as with other PSH technologies, assessing the suitability of a site is not determined by a single factor.



Figure B2-1: Dinorwig Power Station

In recent years, the concept has gained more popularity and a number of projects have been the subject of either concept or feasibility studies, particularly in Australia and US. In advanced stages of development and commencing construction is Genex's 250MW Kidston PSH project in Queensland (Australia)²⁵ which intends to utilise the abandoned gold mine's two existing voids for the upper and lower reservoirs. These opportunities are not just limited to disused or abandoned mine sites like Dinorwig and Kidston, but mine operations nearing the end of their mine life are also being considered.

Challenges, barriers and emerging opportunities

Ten basic criteria have been developed²⁶ (see

²⁴ <https://www.fhc.co.uk/en/power-stations/dinorwig-power-station/> and <https://www.electricmountain.co.uk/History>

²⁵ <https://www.genexpower.com.au/250mw-kidston-pumped-storage-hydro-project.html>

²⁶ <https://www.miningmagazine.com/power-remote-power/news/1372840/mining-towards-renewable-energy>



REFERENCES

- [1] Underground Pumped Hydroelectric Storage, R.D. Allen, T.J. Doherty, L.D. Kannberg, Prepared for the U.S. Department of Energy under Contract DE-AC06-76RLO 1830, July 1984
- [2] Isaaksson G., D. Nilsson, T. Sjostrand, "Pumped storage power plants with underground lower reservoirs. Seventh World Power Conference, Section 2, Paper 160, Moscow, 1968.
- [3] Sorensen K.E., "Underground reservoirs: pumped storage of the future?" Civil Engineering, vol. 39, no. 3, 66, 1969.
- [4] Tam S.W., Blomquist C.A. and Kartsounes G.T, "Underground pumped hydro storage - An overview", First Annual Conference on Mechanical and Magnetic Energy Storage Contractors' Information-Exchange, Luray, Virginia, October 24-26, 1978.
- [5] Beck H.P., Schmidt M., "Windenergiespeicherung durch Nachnutzung stillgelegter Bergwerke", Energie-Forschungszentrum Niedersachsen, Goslar, 31.08.11.
- [6] Uddin N., "Preliminary design of an underground reservoir for pumped storage", Geotechnical and Geological Engineering 21: 331–355, 2003.
- [7] Wong I. H. "An Underground Pumped Storage Scheme in the Bukit Timah Granite of Singapore", Tunnelling and Underground Space Technology, Vol. 11, No. 4, pp. 485--489, 1996.
- [8] Podvysotski A.A., Borodulin A.A., "Pumped-storage power plant with underground reservoir. Structural design. Prospects". Proceedings of the Vingt-cinquième Congrès des Grands Barrages, Commission Internationale des Grands Barrages, Stavanger (N), Juin 2015.
- (9) Underground Pumped Hydroelectric Storage, R.D. Allen, T. J. Doherty, L. D. Kannberg, Battelle, July 1984 Prepared for the U.S. Department of Energy under Contract DE-AC06-76RLO 1830
- (10) <https://www.waterpowermagazine.com/features/featureinvestigating-aquabank/>
- (11) <https://drive.google.com/file/d/1UX95vc5To8r5UYIPEpFB52PWzPSKyh7q/view?usp=sharing>



Supplementary information - Retrofitting PSH on open pit mine

Table 2 Appendix) for use of mine operators to undertake an initial assessment of potential sites and to rank one site versus another. Some of the criteria may not apply to every site, but in general all of them should be considered. For example, topography would apply to a mine site where only one pit exists and the other reservoir must be created but would not be as critical compared to a mine site with two pits with suitable elevation differential, such as Kidston in Queensland, Australia.

A key issue for developers considering mine sites as potential PSH project sites is the significant financial liability associated with the purchase and ongoing monitoring and maintenance of the site to achieve environmental objectives. In most countries, the financial liability is presented in the form of an environmental or reclamation bond. The significance of the bond varies between mine sites depending on a number of factors (e.g. for an abandoned site, the amount of rehabilitation that has been completed). It is important to consider the degree of financial liability and environmental considerations when acquiring mine sites for PSH development.

The table in Appendix also touches on a number of the challenges that may be faced, such as first filling of the storage reservoirs, but another issue is the stability of mine pit walls. Open pit mines are typically very steep to minimise excavation costs and stabilisation measures are usually only focussed on the remaining mine life, rather than satisfying the long-term civil engineering design parameters. The stability of the slopes also need to be considered in the context of the fluctuating reservoir levels – a loading condition that the miners will not have considered in the mine development plan. Good understanding of the geological and hydrogeological conditions is therefore important to manage the risk of pit slope failure.

The steepness of the mine pit walls usually means that there is a large variation in head for a given volumetric change compared to other large reservoir PSH schemes. This can manifest itself into an operational constraint – the range of operating head compared to the rated head of the selected pump-turbine unit – limiting the 'usable' volume of the mine pit shell.

Waste rock dumps may be considered a potential platform for a fully bunded lined reservoir to be located. It will be important to understand the methodology that the miner followed to form these areas. Whilst waste rock is placed in layers and 'compacted' by the mine fleet, the layers can be up to 10-15m deep. These waste rock dumps will not perform as an engineered fill and the risk of significant settlement and deformation during first filling and operation of the reservoir should be carefully considered.

The challenges increase when a PSH project is targeting commercial operation as soon as practicable following completion of the mine operations. If construction of the powerhouse cavern can be commenced early, it may be able to be taken off the critical path. At Middleback Ranges²⁷, the whole design and construction sequence for the upper reservoir was driven by the interfaces with the continuing mine operations and the strategy to overcome the challenge of first filling of the reservoirs.

Cost-efficacy and feasibility

Logic would suggest that development of a PSH project at an open pit mine site should be more cost efficient than a greenfield site. Of course, every project is unique so caution needs to be applied when comparing development costs at different sites. However, the challenge that this technology needs to overcome is the perception that the savings are more significant than can be practically realised.

²⁷ [South Middleback Ranges Pumped Hydro Energy Storage Project, Pre-feasibility Study – Knowledge Sharing Report, SIMEC Mining](#)

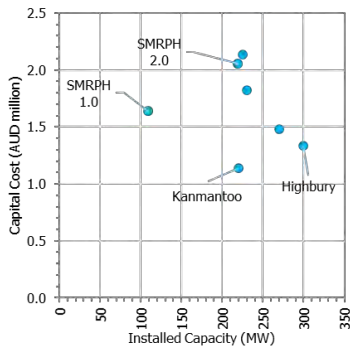

Figure B2-1 Capital Cost vs MW

A comparison of the capital costs published in the 2019 HydroWIREs²⁸ report with three South Australian open pit mine PSH opportunities that were being studied at concept/feasibility level in the same year illustrates this concern. HydroWIREs presents a range of capital cost per MW installed for PSH projects of US\$1.7M to US\$3.2M. The publicly reported capital costs for the three South Australian open pit mine PSH projects (Figure B2-2²⁹) ranged from US\$0.75M to US\$1.6M per MW installed. There was a level of scepticism with the lower end of this range and any suggestion the potential savings offered by an open mine PHES is more than 50% would be misleading. Nevertheless, savings are available.

The ability to leverage synergies between mine operations and the development of the potential pumped storage facility can help reduce capital costs and minimise the lapse between completion of mining activities and the commissioning of the plant. Using the mine fleet to cut back the pit slopes as they develop the mine to align with a profile that meets the long-term civil engineering design parameters will likely cut costs compared to revisiting and stabilizing the steep mine cut slopes at the end of mine operations. Costs of additional work done by the mine fleet should be taken into consideration when evaluating pumped storage economics. For example, utilising the mine fleet to place waste rock material in locations favourable to the construction of the pumped storage structures, such as an upper reservoir embankment, could offer cost savings. The same opportunities do not apply to disused or abandoned sites.

Potential beneficiaries & use cases

The investigation and investment in open pit mine sites for PSH is currently being led by the private sector. Partnerships between developers and mine owners are being forged and local stakeholders are also being engaged. In New South Wales (Australia), the Muswellbrook Shire Council invited interested parties to partner to investigate Bells Mountain Pumped Hydro Project. AGL and the coal mine’s owner are now jointly undertaking a feasibility study of the 250MW scheme. An increasing number of mine owners have also started to consider PSH development as part of the mine closure plan, offsetting rehabilitation costs and creating an ongoing beneficial asset. However, in two known cases the PSH opportunities have been shelved in favour of mine plan expansions to extract further ore reserves in response to upturns in the mineral resources markets. Maybe the window of opportunity for these sites will return in the future.

State/national governments are supportive of these developments but no open pit mine PSH developments are known to be directly promoted by the public sector.

[Supplementary information can be found in Appendix.](#)

²⁸ [Energy Storage Technology and Cost Characterisation Report, PNNL-28866, HydroWIREs, US Department of Energy, July 2019](#)

²⁹ Capital costs of six South Australian PSH projects under study in 2019. Data taken from published figures in public domain. Names of open pit mine PSH projects shown.



PSH utilising underground mine

Lead authors: Dr. Alexander Arch (AFRY Switzerland), Klaus Öhlböck (AFRY Austria), Thomas Johansson (Mine Storage International AB), Mikael Bergmark (Pumped Hydro Storage Sweden AB)

Estimated Technology Readiness Level (TRL): 6-7

Key concept

- Utilising abandoned underground mines as lower reservoirs.
- Environmental impacts are smaller than greenfield PSH developments with underground lower reservoir and upper reservoir constructed on an existing brownfield site.

Technology brief

Pumped storage plants in underground mines are meeting the goal of reduced environmental impact, as very limited additional impact is introduced (impact from the mine is already existing).

For the lower reservoir existing tunnels and galleries are used and the upper reservoir is installed on the surface at the entrance of the mine. Existing tunnels and cavern systems in underground mines allow for reduced CAPEX with respect to the construction of the reservoirs. Additionally, water management is required even if the mine is closed and hence the operation of the pumped storage plant will allow for an additional functionality. Also, with respect to employment, pumped storage plants in underground mines will preserve employees once the mine is closed.

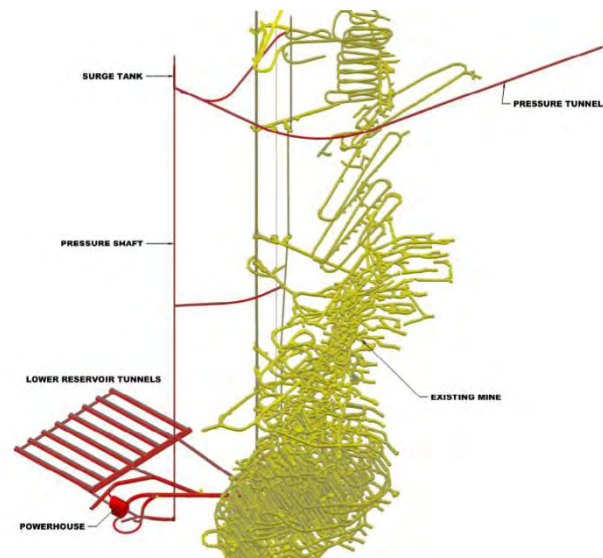

Figure B3-2 PSH Pyhäsalmi - Layout

Modular concepts are enabling a stepwise extension using new abandoned excavated galleries as underground reservoirs. For underground structures to be built, geological conditions have to be thoroughly checked and UPHS concepts are no exception from that. However, local geology in most cases will be far better known compared to conventional schemes as for ongoing mining activities detailed geological knowledge is key. Furthermore, mentioned underground reservoirs use existing excavated volumes (tunnels & galleries) in form of a free surface reservoirs without pressurizing the surrounding rock matrix. UPHS schemes are built up from standard engineering approaches and uses standard components as in conventional pumped hydropower schemes. However and as it is also mentioned in various investigations³⁰ every mining location represent unique circumstances which have to be analysed case by case.

Although these advantages are evident, up to now only conceptual designs and feasibility studies were conducted. There is, however, a planned project to begin construction in 2021 at Åland (Finland). This one is further presented below. Detailed studies were conducted at Pyhäsalmi mine in Finland³¹ or the slate mine in Martelange in Southeast Belgium³². Furthermore, several investigations exist with abandoned coal mines as in Australia (Centennial Fassifern coal mine) or in Germany (Prosper-Haniel mine in Bottrop, Porta

³⁰ An Exploratory Economic Analysis of Underground Pumped-Storage Hydro Power Plants in Abandoned Deep Coal Mines, Reinhard Madlener & Jan Martin Specht, *Energies* 2020, 13, 5634; doi:10.3390/en13215634

³¹ An innovative pumped-storage project in an underground mine, K. Öhlböck, G. Lang, T. Weissensteiner – *Hydropower* 2017

³² Underground Pumped-Storage Hydropower (UPSH) at the Martelange Mine (Belgium): Underground Reservoir Hydraulics, V. Kitsikoudis, P. Archambeau, B. Dewals, E. Pujades, P. Orban, A. Dassargues, M. Piroton, S. Erpicum, *Energies* 2020, 13, 3512



Westfalica or Hartz mine)^{33 34}. Technical feasibility was confirmed but they lacked viable business case in current energy market designs.

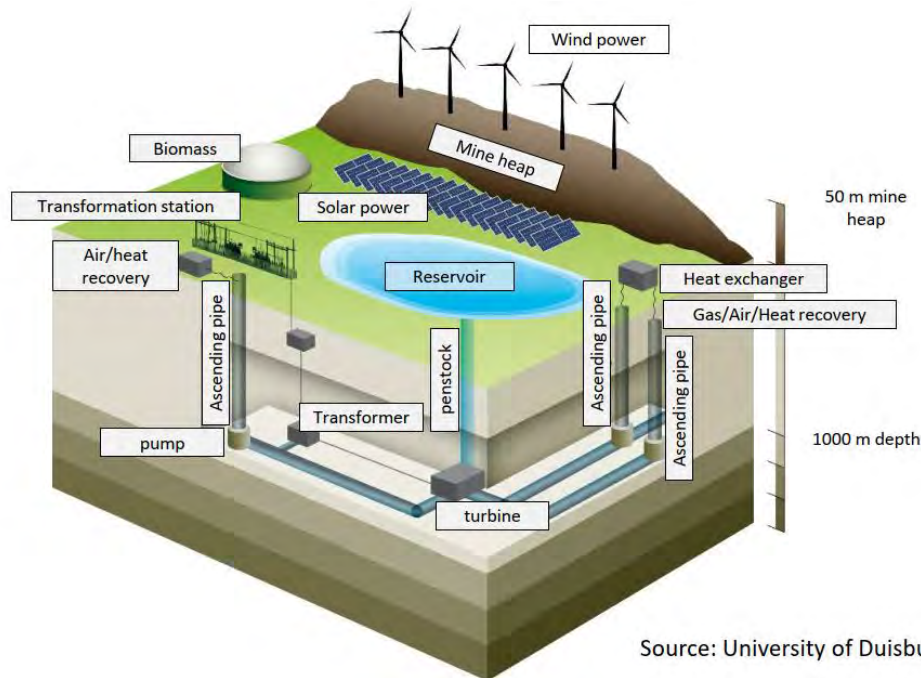

Source: University of Duisburg-Essen

Figure B3-3: Pumped hydro idea in the Ruhr district in Germany at the Prosper-Haniel black coal mine

Case study: Lilla Båtskär, UPHS facility

At the island of Lilla Båtskär south of Åland (Finland), a pilot facility will be constructed to showcase the concept of UPHS. The old iron mine, that was abandoned in 1959, is today water filled. The company Pumped Hydro Storage Sweden AB is the main developer of the facility which will be a small version of the solution with a capacity of 2MW/8MWh. The mine consists of a 290 m vertical shaft and the lower reservoir is a 1.6 km drift at a depth of 250 m. Construction is planned to start during 2021. The first step is to empty and secure the mine, after which construction the turbine room, outlet into the Baltic sea mine dam etc. will be conducted, as well as installation of pipes and other equipment. On the island, there is also a wind farm and an existing grid connection. The prerequisite of the mine is therefore ideal for showcasing, as many of the challenges that might face a large-scale facility is present. In the appendix, an aerial view as well as a view of the mine layout is presented.

Challenges, barriers and emerging opportunities

In general, a successful implementation of a pumped storage plant in an underground mine will depend on several key factors:

Geology: Mining engineering, with the goal of exploiting the mine in the most economical way, do not always applying the same design principles as for permanent installations that a pumped storage plant requires. Therefore, existing underground reservoir infrastructures might require measures to guarantee stability during filling and emptying and as well as water tightness.

Water Quality: Using the existing underground water might pose a challenge due to the existence of chlorides and sulphates, which for instance requires special attention with respect of the potential risk of corrosion and environmental concerns.

³³ Windenergiespeicherung durch Nachnutzung stillgelegter Bergwerke, H.-P. Beck, M. Schmidt (Hrsg.), Energie-Forschungszentrum Niedersachsen, 2011

³⁴ Entwicklung eines Realisierungskonzeptes für die Nutzung von Anlagen des Steinkohlebergbaus als Unterirdische Pumpspeicherkraftwerke - 64.65.69-PRO-0039, Final Report 2014



Transport: In general, underground mines are accessed through shafts and in some cases, transport is done via road infrastructure. Installation of equipment (most notable transformers) within deep mines is challenging as existing hoisting equipment might be the limiting factor. Most notable for very deep mines, special “elevators” have to be designed to ensure the transportation of the equipment during construction and operation, which increases the CAPEX.

Accessibility: Apart from the transport, overall accessibility is key, not only during construction but also during operation. Potential sites shall serve with several accesses to provide physical access to the powerhouse as well as space for the energy transmission infrastructure and HAVC (Heating, air-conditioning, ventilation and cooling) systems. If new access tunnels or shafts have to be constructed economical attractiveness of an underground pumped storage plant is reduced.

Ongoing Mining operation: Most interesting sites are linked to sites with still ongoing mining operation, because the infrastructure is well maintained and can be easily accessed without the need of rehabilitation of abandoned tunnels and galleries. However, in these mines the mining purpose is the prevailing one and energy generation will play a second role. Therefore, logistics and operation of the mine shall be key parameters within the PSH design phase and future exploiting strategy shall already include the installation and construction of the pumped storage plant. This will allow for a smooth construction phase as well as reduce the need to rehabilitate the already constructed underground galleries and tunnels, which will serve as storage facilities.

Permitting & Licencing: In several countries it is not legally possible to have an energy facility and a mining facility at the same location occupying the same area. Moreover, energy and mining facilities in most cases do not have to comply with the same regulations and standards. Hence, conflicts may arise if implementing a generation facility in a mining concession area.

Legal Constraints: During mining operation the closing of the mine and the corresponding cost in general are already taken into consideration within the economics of the mining operation, as usual the mining owner is responsible to ensure a save environment after closing. Although a UHPS can beneficially contribute to the needs after closing (water management, continuous inspections of the abandoned galleries, etc.) inherited liabilities might be a constraint for a UHPS investment if responsibilities are not properly addressed and regulated ³⁵.

However, if the implementation of a pumped hydro scheme can be introduced in the very beginning and during the exploitation of the mine, underground structures can be cost effectively prepared during the mining operation allowing for an economic realization of the PSH as well enabling the access during construction and operation. This does not only enable the mine to become an asset for the energy transition, but also and additional income for the mine developer.

Cost-efficiency and feasibility

Implementation cost will be very site specific as the different geological and accessibility conditions are. However, feasibility studies show that cost of an underground pumped storage plant in a mine can be in the range of a new build or even lower. Based on investigations done in Germany a cost range with 1,200 to ~2,400 EUR/kW was stated ³⁶. Studies from Spain show an average value for UHPS in the order of 1'675 EUR/kW based on full usage of existing infrastructure and without the excavation of new galleries for the underground reservoir ³⁷. However, up to now there is no proven number for UHPS from an executed project and a comparison to conventional PSH recently built in Europe might be misleading as in most cases these projects use existing reservoirs or are extensions of already existing plants. Thus, overall economy will strongly depend on the specific parameters and also the energy market environment – apart from the revenues coming from the balancing power market, ancillary services (e.g. frequency control) have significant revenue potential. Benefits regarding the (future) mining water management also in case of closing of the mine will further support the profitability. In this context it shall be noted, that inherited liabilities and corresponding cost shall be borne by the mine operator as such cost might considerable decrease the overall UHPS profitability. Furthermore, PSH in ongoing mines also pose the possibility of self-

³⁵ SCIENCE BUSINESS SOCIETY DIALOGUE CONFERENCE 2017, Linking Science, Society, Business and Policy for the Sustainable Use of Abandoned Mines in the SADC Region, <http://dx.doi.org/10.17159/assaf.2018/0025>, Academy of Science of South Africa

³⁶ STE Research Report – Unconventional energy storage (Unkonventionelle Energiespeicher), Peter Stenzel, Sylvestre Baufumé, Richard Bongartz, Jochen Linssen, Peter Markewitz, Jürgen-Friedrich Hake, IEK-STE (03/2012) -

³⁷ Economic feasibility of underground pumped storage hydropower plants providing ancillary services, Javier Menéndez, Jesús Manuel Fernández-Oro and Jorge Loredó, Appl. Sci. 2020, 10, 3947; doi:10.3390/app10113947



consumption of energy and in this way reduce the high energy costs for the mining company, as in most cases nearly 100% reliability of power supply is reflected in high energy tariffs. With their own PSH, mining companies have the possibility to ensure peak power demand on their own and thus negotiate more attractive energy supply contracts allowing for a reduced reliability. By combining the plant with installations of local renewable energy production, the mining company could further reduce their carbon footprint. In the case of off grid mines, this solution could enable production without expensive and carbon intensive diesel generators.

Potential beneficiaries & use cases

Apart from mining companies, which might be able to better manage their power consumption and, in case of the closing, reduce the need for water management, revitalization of abandoned old mines is also in focus when talking about environmental and social aspects. The possibility to install an artificial lake at the surface that improves the appearance of the abandoned area might also trigger a better acceptance of the surrounding population. This can also be the motivation for authorities to revitalize unattractive landscapes, which for active or abandoned mining areas is often the case. As most visible parts and the sound polluting equipment is located underground, the local objections are likely to be limited,

[Supplementary information and diagrams can be found in Appendix.](#)



Double-fed Induction Machines in Hydraulic Short Circuit Operation – The Frades 2

Lead authors: Joana Santiago (EDP Gestão da Produção de Energia SA) and Alexander Jung (VOITH HYDRO)

Contributors: Diogo Cordeiro and Andressa Bade (EDP Gestão da Produção de energia SA), and João Delgado (EDP NEW R&D - Centre for New Energy Technologies)

Estimated Technology Readiness Level (TRL): 6-7

Key concept

- Applying Double-fed Induction Machines to Hydraulic Short Circuit (HSC) for simultaneous operation in pump and turbine mode with two pump-turbine units, increasing flexibility through extending the power plant operation range.

Technology brief

Frades 2 is a pumped storage powerplant (PSP) located in Portugal and operated by EDP that has been operating since 2017.³⁸ This PSH is equipped with two variable speed units that are composed of two 400 MW reversible pump-turbines coupled with 420/433 MVA doubly-fed induction machine (DFIM) motor-generators. These units are Europe's largest and most powerful DFIM, consequently establishing a significant technological advance for variable speed PSHs. This goal was achieved thanks to the development of frequency converter technology over the past few years, which made it possible to apply variable speed generator-motors of large power input/output, thereby leading to unique advantages for grid stabilization due to the application of this variable speed technology.

In a DFIM, AC current is fed to the rotor of the asynchronous motor-generator through a frequency converter enabling a unit rotational speed variation of typically +/- 10% resulting in a frequency converter rated power of 10 % of the rated motor-generator power. This is achieved by a Voltage Source Inverter (VSI) using IGBT or IGCT used as frequency converters to enable fast response. In the Frades 2 PSH, the two DFIM reversible pump-turbine units have a variable speed range of 350 min⁻¹ to 381 min⁻¹.

Frades 2 is one of the demonstrators of the XFLEX HYDRO project [2]. In this scope and taking the advantage of the DFIM, the objective is to demonstrate an improved hydropower potential in terms of plant efficiency, availability, and provision of flexibility services to the grid.

Applying the DFIM to the Hydraulic Short Circuit (HSC) for simultaneous operation in pump and turbine mode with the two units, will extend the power regulation capability for the ancillary system services market by adding the additional range of 0-200 MW in pumping mode, and of 0-100 MW in generating mode. Therefore, the HSC aim at maximizing performance and increasing flexibility through extending the power plant operation range, which will increase the availability to provide balancing services bids into the market. Furthermore, HSC allows the possibility to use one turbine to provide voltage regulation and, as such, increases the capability to provide reactive power support to the grid.

HSC can also be realized with fixed-speed (synchronous) machines. The major advantage of using a DFIM is the possibility of achieving much steeper power gradients. With a fixed-speed machine, the power control speed is directly related to the time constants for power adaptation in the hydraulic machine. Thus, it is in general limited to supply Frequency Containment Reserve (FCR –i.e. primary frequency control). With a DFIM, the frequency converter allows for superior control strategies within the speed ranges of both turbine and pump within the HSC. This enables additional, much faster power regulation processes that support additional ancillary services like: Fast Frequency Response (FFR) or Virtual Inertia emulation (VI) together with the enhanced operating range that is realized through the HSC operation.

³⁸ Hildinger T., Ködding L., Eilebrecht P., Kunz A., Henning H., "FRADES II – Europe's Largest and Most Powerful Doubly-fed Induction Machine. A Setp Ahead in Variable Speed Machines"



Challenges, barriers and emerging opportunities

Frades 2's units allow the implementation of additional enhanced flexibility services such as virtual inertia emulation ("synthetic" inertia) and FCR. By providing these services, the plant will play an important role on the grid while other synchronous generators, such as the fossil-fuel gas-fired and coal-fired power plants, are progressively decommissioned, which decrease the amount of synchronous inertia in the electric power grid.

Cost-efficacy and feasibility

The use of a variable speed motor generator generally offers advantages that can justify the higher investment. These include, among other benefits: (1) Power control in pump operation; (2) Extended turbine operating range; (3) Faster ramp-up and ramp-down of the units compared to fixed-speed; (4) Dynamic network support; (5) Increase the availability to provide balancing services bids.

Frades 2 has been in operation since 2017 in a competitive energy market composed of different energy producers and consumers. Moreover, the Frades 2 variable speed technology provides system services that fixed speed turbines do not allow, for example fast frequency response in both pump and turbine modes, faster provision of FCR and power regulation in pumping mode.³⁹

One of the major risks for DFIM technology is the uncertainty of the type of market and remuneration scheme for several future ancillary system services. For instance, FFR, although not yet considered in the Continental Europe markets for frequency system services, it is already being explored in the UK, Irish Islands and Nordic Countries.^{40,41} Also, only AEMO (Australia) plans to include Synthetic Inertia in the basket of frequency system services.⁴² A common ground in the international regulations, which would allow major revenue sources and possible business models to be identified, would significantly lower the risk for hydropower project promoters looking to deploy technologies operating in the frequency system services market.

Potential beneficiaries & use cases

The PSH variable speed machines (with or without HSC) are a solid and readily available solution for achieving high standards in providing energy management flexibility and security. Hence, the Frades 2 technology profile is a valuable use case for governmental authorities, Transmission Systems Operators (TSOs), and Power Generation Utilities that aim to integrate large shares of non-dispatchable renewable energy resources into the power grid; because it will require guaranteed availability of flexibility in generation or consumption of energy, including fast dynamic response to ensure electric power system stability. Therefore, stakeholders across the entire value chain of the electric power system in countries The Frades 2 profile could be useful for governmental authorities / TSOs / Power Generation Utilities who need high-capacity solutions for flexibility challenges. Major beneficiaries of the DFIM-PSH technology would be those countries with energy approaches similar to Portugal, which are actively increasing solar/wind generation, while closing conventional thermal power plants.

³⁹ INESC TEC, "Flexibility, technologies and scenarios for hydropower", XFLEX HYDRO project.
<https://xflexhydro.net/flexibility-technologies-and-scenarios-for-hydropower-report>

⁴⁰ EU-SysFlex Consortium, "Product Definition for Innovative System Services - D3.1," 2019.

⁴¹ Inertia2020 Working Group, "Technical Requirements for Fast Frequency Reserve Provision in the Nordic Synchronous Area," ENTSO-E, Brussels, 2019.

⁴² Australian Energy Market Operator (AEMO), "Fast Frequency Response in the NEM - Working Paper," in Future Power System Security Program, 2017



Hydraulic Short Circuit at High Head PSH – Grand Maison

Lead author: Jean-Louis DROMMI – EDF Hydro Engineering Centre

Estimated Technology Readiness Level (TRL): 7

Key concept

- Hydraulic Short Circuit for simultaneous operation of pump and turbine units
- Grand Maison will provide half of France's total requirement for secondary frequency control

Technology brief

Grand Maison is located in the French Alps in the shadow of Alp de Huez. At 1800 MW capacity, this powerful pumped storage plant (PSP) makes use of a very high head (900m) with high elevation of its upper reservoir, and operates either in turbinning mode when power needs to be generated, or pumping mode when there's excess power on the grid. The PSH has two types of units installed:

- Reversible pump-turbine units (8 in total, 150 MW per unit); which can operate either as a pump or as turbine, at fixed speed either way.
- High head turbine units (4 in total, 150 MW each currently being updated to 170 MW); equipped with Pelton runners which can adjust power from almost 0 to full load.

Currently, the PSH plant only operates in two modes:

1. Turbinning: where power output may be adjusted at will, particularly through the Pelton units.
2. Pumping: where power consumption can only be adjusted step-by-step, according to number of pumps in service.

It is proposed at Grand Maison to implement a third operating regime, 'Hydraulic Short Circuit', where pumps and Pelton turbines operate simultaneously to provide frequency regulation. This means that the power absorbed by a pump can be varied by the concurrent power output from a Pelton unit. Energy is thus spent in order to provide frequency regulation.

Around the world some PSH plants have been specifically designed to operate this way and do so (e.g. Kopswerk II, Hongrin Léman, Obervermuntwerk II,); however the vast majority were only designed to either generate or pump exclusively, not at the same time. Introducing the technology where it was not originally intended, therefore requires investigation.

This new approach of a 'Hydraulic Short Circuit' addresses the increasing need for grid frequency support. Especially during periods of low grid loading, when pumping occurs, and where regulating units on the system are scarce. As an order of magnitude, with four Pelton turbines operating together with the pumps, the PSH offers more than 500 MW of regulating power for the grid. This represents up to 50% of France's total requirement for secondary frequency control, reflecting the important role of Grand Maison PSH on the grid.

Challenges, barriers and emerging opportunities

To implement the technology within the existing PSP, several challenges need to be addressed, both on the hardware side and control side.

To begin with, this operating mode of operation must not deteriorate the existing asset, which means it must first be theoretically studied to identify any potential risk. This involves studies focused on the hydraulic issues that might arise in the water passageways, i.e. to examine the operating limits of the PSP. For this, the fluid dynamics within the water passageways has been modelled extensively.

Also, with a third mode of operation being available, the expected annual hours of operation of the Pelton turbines are expected to increase 30 to 50%. This means more maintenance would potentially be required since Pelton checks are proportional to operation time. Modernisation work at the PSH is introducing new



hooped Pelton runner designs, which require up to five times less inspection than standard forged Pelton turbines. This will help address the issue of increased maintenance.

On the control side, challenges include the optimal use of the new mode of operation when bidding into the ancillary service markets. Full knowledge of the operating cost and the energy value of stored water is required for this purpose. At the site, a smart control strategy is to be deployed (Smart Power Plant Supervisor 'SPPS'), to select the most efficient combination of pumps and turbines to achieve a desired operating point.

At the site, no extra environmental impact is foreseen. However, when looking at the broad electricity generation picture, the technology enhancement and availability of regulating power in pumping mode, could help avoid use of fossil-fired generating units and associated CO₂ emissions otherwise used for system balancing.

The next step at Grand Maison will be a demonstration phase with full automatic activation, scheduled to take place from mid 2021 until the end of 2022. It will then be decided, from lessons learned during the testing programme, if the new mode is worth offering as a grid service.

Cost-efficacy and feasibility

The Hydraulic Short Circuit method makes use of an existing asset with its major equipment installed, representing the bulk of initial investment. Implementing the technology, first requires checks that the simultaneous operation of pump and turbine units is technically feasible. And then, if so, the main effort concentrates on unit controls and the plant's Supervisory Control and Data Acquisition (SCADA) system, to enable the simultaneous operation in practice.

Therefore, the cost of the technology is predominantly linked to the studies and software, rather than new equipment. As an order of magnitude, these activities can be roughly estimated to less than 10,000 Euros per regulating MW (€10,000/MW), which is substantially lower than other current technologies.

Considering the uncertainty in the electricity market, and the associated risks of investing into electrical assets, the hydraulic short circuit technology offers an attractive alternative – providing ancillary services with a very low capital risk, quick return and benefits to grid safety.

As an added value to utilities operating a wide portfolio of generating assets, the extra service offered by hydraulic short circuit also provides another means of optimisation for the overall generation fleet.

The vast majority of PSPs around the world do not operate with simultaneous turbinning and pumping; suggesting the potential for this technology is wide. To incentivise investors, long term contracts for ancillary services would help the technology to be more widely considered and, if feasible, implemented.

Potential beneficiaries & use cases

The Hydraulic Short Circuit method targets pumped storage hydropower utility companies. If implemented, the technology would then benefit both the asset owner, thanks to extra revenue from flexibility services, and the grid operator, with respect to the ancillary services offered by the technology for the grid.

The technology could be deployed at any PSH site worldwide.

The technology provides regulating power for the grid to accommodate non-regulated renewable energy, which is increasing its share in the energy mix. This regulating power can be offered mostly as a secondary frequency control, but a proportion of the available MW may also be kept for primary frequency control. Finally, the technology also offers benefits for portfolio optimisation for hydro fleet operators.



Pumped Storage operating range extension – The Alqueva

Lead author: Guillaume Rudelle, GE Hydro

Contributors: J. Brindon, GE Hydro; Cláudia Gouveia, EDP Gestão da Produção de Energia, SA; João Delgado, EDP NEW R&D - Centre for New Energy Technologies.

Estimated Technology Readiness Level (TRL): 7-8

Key concept

- Extending the operating range on pump-turbine units for a cost-effective medium-term solution to increase the flexibility of the existing fleet.

Technology brief

Alqueva is a hydroelectric pumped storage powerplant located on the Guadiana river in the south of Portugal. It is owned by EDP and it is part of the Alqueva Dam complex, an infrastructure that created the Europe largest artificial lake. The power plant includes two separate powerhouses, Alqueva I, commissioned in 2004 and Alqueva II, commissioned in 2017. Each powerhouse is composed of two fixed-speed Francis reversible pump-turbine units equipped with a synchronous motor-generator. Each unit features a maximum generating power of 130 MW.

Extending the operating range is a technical solution that can be evaluated and applied on each unit of the PSH fleet. It represents a cost-effective medium-term solution to increase the flexibility of the existing fleet. This solution offers the opportunity to significantly increase the power band of the PSP, i.e. the power range that the powerplant can deal with in few seconds to ramp-up or ramp-down the energy produced. This range is typically from 50% to 100% of nominal power in turbine mode and could be increased to potentially reach a 0-100% operation.

Increasing the operating range of a unit means being able to operate at partial load and deep partial load. But traditionally, the units are not designed to operate in these areas where a wide range of unsteady hydrodynamic phenomena can occur which can impact the structural integrity and therefore the lifetime of the machine. Enabling the operating range extension supposes to evaluate the behaviour of the machine at part load and assess the benefits & risks associated.

In addition to the extension focused on each unit, the global operating range of the powerplant can also be extended by smart dispatch of the load between the units and the ability to operate in pump and turbine mode simultaneously on 2 units of the same plant. This mode of operation, "Hydraulic Short Circuit" (HSC), allows for load (and frequency regulation) control in pumping mode using synchronous fixed-speed hydraulic units.

This enhanced configuration will enable to consider the powerplant as a controllable load. Indeed, even if the pumping is always at rated power (fixed amount of energy absorbed at a given head), the capability to control the production of another unit in generation mode offers wider control opportunities and increase significantly the global operating range of the powerplant. In particular, a wide continuous power variation from negative to positive in a matter of few seconds is accessible for powerplants with multiple units (such as Alqueva and its 4 units), offering a highly flexible power control.

This mode offers an opportunity of power regulation in global pumping mode even if the units are individually designed for fixed speed and thus are pumping always at rated power. As an example, see the figure below, where one unit of Alqueva 2 is operating in turbine mode, while the other unit is operating in generating mode.

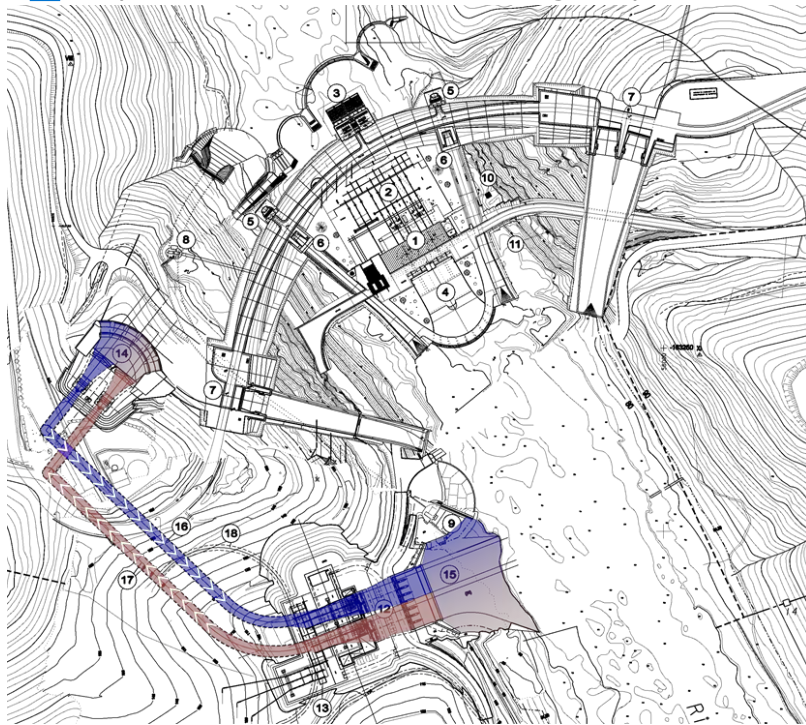

■ Generating mode
■ Pumping mode

European Commission⁴³.

Figure B6-1: Top view of Alqueva hydroelectric pumped storage powerplant

As more intermittent renewable energy sources penetrate develop and put pressure on the grid stability, operating at partial load is a now global trend in the hydro industry, especially for new projects, the knowledge about the associated hydrodynamic phenomena and their consequences is growing. Regarding existing machines, some R&D projects have been conducted over the past 10 years to experiment several strategies and tools to enable these extensions without any physical modification of the machines with various levels of complexity and cost: mainly Salamonde & Alqueva, both PSH in Portugal (EDP/GE), but also run-of-rivers plants Valeira and Carrapatelo in Portugal (EDP/GE).

Currently, an extensive approach is being implemented on Alqueva powerplant in the frame of XFLEX HYDRO project, supported by the

Challenges, barriers and emerging opportunities

A range extension assessment is based on a trade-off, a profit/risk analysis. The challenge is the development of efficient tools to perform the assessment of both risks and profits.

In terms of risks, the major issue is the understanding and characterization of unsteady hydrodynamic phenomena at partial load (helical vortex rope or inter-blades vortices, hump zone, etc.) and their impacts on the structural integrity of the machine (e.g., runner cracks, cavitation erosion, wear and tear on shaft line). Empirical methodologies have been or are being developed based on condition monitoring, detailed measurement campaigns in-situ or on test-benches. A full simulation approach is promising as it does not immobilize the machines and can be done offline, but has not reached a satisfactory level of reliability to avoid an experimental validation.

R&D efforts are still needed to provide fast and reliable tools to simulate these unsteady hydraulic phenomena and then their consequences on structural components lifetime. On the other hand, advanced automatic numerical optimizers to determine the smarter way to dispatch the load between the units of a powerplant taking into consideration risks (e.g., pressure fluctuations, cavitation, wear & tear, RUL, maintenance plan) and the profits (ancillary services remuneration) also need to be developed and put on the market.

This range extension solution certainly fits the global hydro context. Firstly, ageing of the fleet meaning that the industry focuses on assessing what is most impactful for remaining lifetime. Secondly, changing hydro operation paradigm to enable the higher integration of unpredictable renewable energy sources meaning

⁴³ www.xflexhydro.net



operating more and more at partial load. Finally, the digitization of the industry and development of condition monitoring systems that provides feedback on machine behaviour.

Globally, this solution is powerful as it can leverage the whole existing PSH fleet to ensure grid stability, and minimal for the environment as the idea is to utilize existing machines without modification.

Nevertheless, to implement this method, it is key that the ancillary services are valued as they are critical for the grid stability in the energy transition context. Besides for hydropower plants, operating at partial load means decreasing production and its related revenues. Finally, to accelerate and quickly leverage this solution, public funding should not only consider greenfield projects which take many years to permit and build but also existing fleet improvement which can be accomplished relatively quickly.

PSH featuring fast ramp-up and ramp-down times will allow energy utilities to play a competitive role in the future energy system, as this technology is capable of providing a large share of power generation or consumption in an order of magnitude from MW to GW, in a time window ranging from tens of seconds (targeting the ancillary system services) to days (depending on reservoir size) in case of unavailability of wind and solar resources.

Cost-efficacy and feasibility

Extending the operating range of the PSH fleet is a cost-effective solution widely deployable in the worldwide PSH installed fleet. This solution requires a limited CAPEX (many extensions can be achieved without changing any equipment), and an outage reduced to several days to implement sensors and perform site measurements.

On the other hand, risks exist, if the extension is not mastered and if the machine operates for a too long period in damaging regimes, impact on equipment lifetime can be dramatic, potentially leading to structural cracks in blades and shafts resulting in long outages as machines are repaired.

As a range extension is a risk analysis, the total cost varies depending on the risk accepted (balance between cost vs accuracy of the analysis): from few tens of thousands to up to half a million euros. The methodology can be adjusted from a vibratory analysis based on condition monitoring of accessible components, to a detailed combination of simulation, site test and model test. In the coming years, the cost could be even reduced due to the growing feedback of experience of O&M and progress in unsteady hydrodynamics simulations.

Today, experience is not sufficient to tackle the full range extension potential without cross-checking and mixing approaches. And the cost for plant operators remains high compared to the potential gains when ancillary services remain poorly remunerated. Thus approaches fully based on simulation or on condition monitoring, coupled with OEM technical expertise, could be used to reduce risk of damaging hardware and thus can justify support of public funding. Usually, a range extension analysis can be performed in less than a year which is fast compared to solutions that require building new physical systems.

Potential beneficiaries & use cases

The proposed range extension solution is cost-effective, quick to implement and widely deployable (potential dissemination to the whole worldwide installed PSH fleet). It has no impact on the local environment & communities as it is only aiming to optimize the use of existing sites & equipment. On a system operator point of view, this solution should thus be considered as quickly actionable in market design. The main barriers are mainly economic (ancillary system services such as frequency regulation are poorly valued). Thus public funding targeting the development of associated tools and methodologies would be a major aid to help address challenges with adding and integrating more renewable energy sources to the grid.

Finally, utilities and PSH owners should be more informed about the capabilities of this operating range extension solution. This method suits any country seeking to increase renewable integration in their electricity mix. The solution is notably interesting for weak grids, island or outlying grid parts.

[Supplementary information can be found in Appendix.](#)



Obermeyer Pump Turbine: Cost Effective Pumped Storage Hydropower

Lead Authors: Henry Obermeyer/Obermeyer Hydro, Jeff Gessaman/Obermeyer Hydro and Claudiu Iavornic/Obermeyer Hydro

Estimated Technology Readiness Level (TRL): 3

Key concept

- Submersible pump/turbines and generators well suited for existing hydropower sites and at dams that are not currently being used for power generation; applicable for PSH units up to about 100 MW.

Technology brief

Reversible pump turbines for pumped storage hydropower are generally installed well below tailwater level in a cavern, or shaft, powerhouse to provide sufficient pressure at the inlet to prevent cavitation. Such facilities are expensive and require suitable geology. The Obermeyer pump turbine seeks to reduce powerhouse costs by utilising a runner with a toroidal flow path that redirects the water approximately 180 degrees (see Figure 1). This configuration allows the Obermeyer pump turbine to be mounted at the bottom of a "well" where the water enters and exits the pump turbine from above (see Figure 2). This significantly reduces the required civil and concrete work at site. The simple underground structure may be constructed under a wide range of geological conditions. Geological risk is further mitigated by the fact that a limited number of borings can reliably characterize the entire excavation.

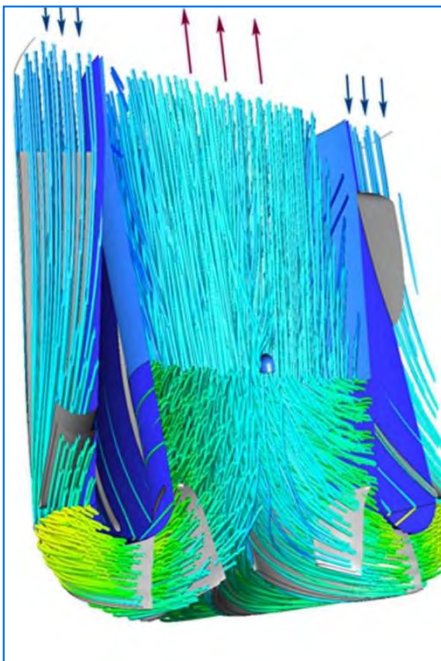

Figure B7-1: CFD image showing flow path of water installation

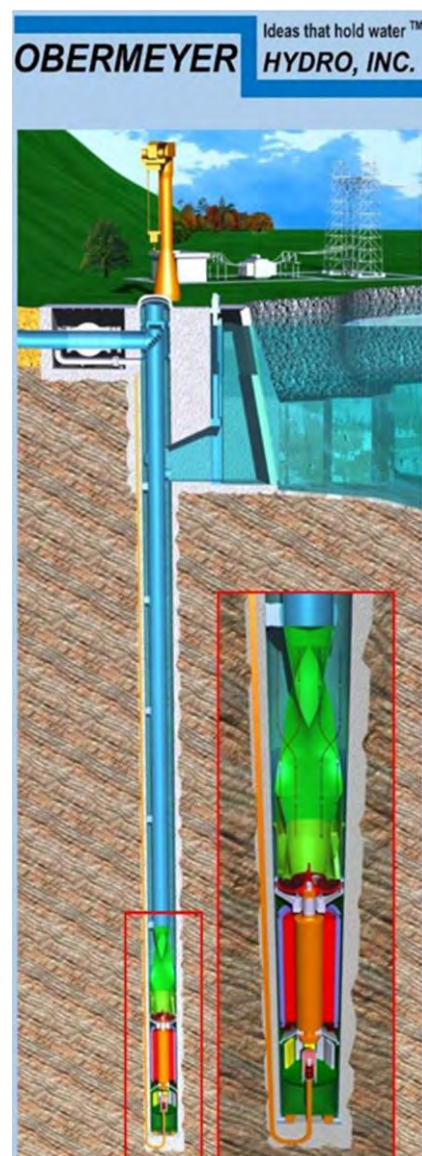

Figure B7-2: Obermeyer pump turbine



This simplified storage solution creates large-scale grid storage opportunities with advantages over conventional and ternary-type configurations. Simplified construction and reduced installation costs can tip the scales at sites that were previously infeasible.

Computational fluid dynamics (CFD) shows the efficiencies of this pump turbine design to be approximately 95% in pumping mode and 94% in turbine mode. This level of hydraulic efficiency promises improved overall system efficiency which is particularly beneficial for the round-trip characteristic of a pump storage hydro site.

The technology readiness level for the pump turbine is TRL 3: Extensive CFD analysis by multiple parties shows high efficiency. The submersible motor and generator is considered TRL 9 as submersible motors are commercially available in multi-megawatt sizes.

Obermeyer Hydro is currently designing and building a prototype unit to confirm CFD results and evaluate performance over the full operating range. This test will utilize a unit with a 240 mm runner and will be testing the unit in the pump configuration. A second series of tests is in the planning phase. These tests will operate the unit in pump mode and turbine mode and will utilize a unit with a 500 mm runner. The second series of tests will be conducted in accordance with IEC 60193 (Hydraulic turbines, storage pumps and pump-turbines - Model acceptance tests).

Challenges, barriers and emerging opportunities

The Obermeyer pump turbine design has a range of specific speeds similar to Francis pump turbines. Thus, the boundary conditions for head are similar to a Francis pump turbine and in the range of 40 m to 600 m. The analysis conducted shows that the Obermeyer pump turbine could be utilized in any site that is suitable for a Francis pump turbine. The Obermeyer turbine would provide a similar unit operating range of power and flow.

The units can be lowered into operating position and/or or raised to the surface for inspection or maintenance with auxiliary water pressure acting on a hoisting piston that is at the bottom of the machine. This auxiliary water passage can also be used to pump silt from the bottom of the "well" on a periodic basis.

The Obermeyer pump turbine is well suited to provide a pumped storage solution for unit sizes down to 1MW and even lower. With reduced installation costs, this may prove attractive for the operator of a renewable energy site.

A significant up-front cost in pumped storage hydro sites is permitting and licensing. Although the Obermeyer pump turbine reduces site installation costs, the permitting costs remain the same. These permitting costs tend to limit pumped storage hydro sites to large installations where the permitting cost is relatively small compared to the overall costs and the revenue potential. Smaller, local utilities who have an attractive pumped storage hydro opportunity may find the initial permitting costs prohibitive. Implementation of smaller pumped storage hydro installations could be facilitated with a reduced cost in permitting.

The relatively small footprint of the Obermeyer pump turbine makes it well suited to being utilized in existing hydropower sites and at dams that are not currently being used for power generation. Pumped storage capability may be added to existing hydro power stations without the need for large shaft or cavern powerhouses that may not be feasible adjacent an existing dam and powerhouse. Overall costs are particularly attractive at existing hydro sites where the dam, reservoirs, penstocks and switchyards are already in place. One would need to modify the penstock to introduce the Obermeyer pump turbine, but this would be at a fraction of the cost of a new penstock. The Obermeyer pump turbine could be used as a pump only with generation via the existing hydro turbine, or it could be used as a pump turbine which would increase the site generating capacity.

Cost-efficacy and feasibility

As part of the U.S. Department of Energy Water Power Technologies Office’s HydroNEXT initiative, Obermeyer Hydro was awarded \$1.18 million to further develop this advanced pumped storage hydro configuration. This effort included a cost analysis of an Obermeyer pump turbine site compared to that of a conventional pump turbine. The results show a 33% reduction in overall installation costs with most of the savings coming from reduced civil costs and underground work (see Figure 3).

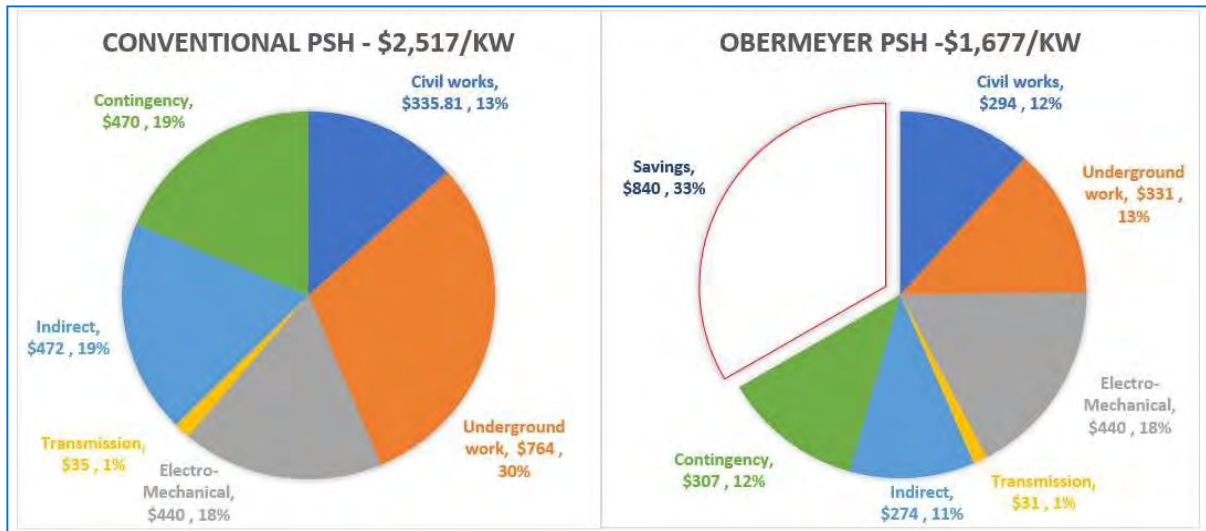

Figure B7-3: Estimated Cost Saving – Tabular data provided in Appendix

Risks in the implementation of this technology are existing, but manageable. The pump turbine is predicted to behave very much like a Francis turbine in a pumped storage hydro installation. This range of operation will need to be established with the physical testing that is described above. For high head applications, where significant submergence is required, the generator and auxiliary equipment will be mounted below the pump turbine (See Figure B7-2). This will require some attention to protection of the generator and other equipment from ingress of water at tailwater pressure. Obermeyer Hydro has successful operating experience with submersible hydro turbines at such depths of submergence. For lower head installations, where submergence requirements are reduced, a conventional air-cooled generator can be mounted above the pump turbine similar to a vertical pump configuration (see Figure 4). This allows for the use of the same motor generator design that are used in vertical Francis pump turbine applications. This is an option that reduces the risk associated with locating the motor generator and auxiliary equipment below water level.

For many sites, the geologic risk of installing an Obermeyer pump turbine will be lower than those associated with a conventional pump turbine installation. This is due to the reduced underground structure and excavation work required. Each Obermeyer pump turbine requires a single “well” slightly larger than diameter of the pump turbine runner. When comparing this to the earth work associated with a conventional pump turbine powerhouse, there are more options for pump turbine location and a reduced probability of encountering a problem during excavation. This reduced footprint may enable pumped storage hydro sites in locations that would not accommodate a typical cavern powerhouse.

Potential beneficiaries & use cases

It is believed that the reduced cost for installation makes the Obermeyer pump turbine attractive to utilities and power companies that are looking to minimise storage installation costs. The Obermeyer pump turbine may also make pump storage hydro attainable for developing countries. The technology could also be utilized in a modular fashion were one or two units are



initially installed at a site. As budget allows and power demands increase, the number of units could be increased without the significant investment in a new cavern, or shaft, powerhouse.

[Supplementary information can be found in Appendix.](#)

Hybrid Systems

Hybrid systems are designed to couple pumped storage hydropower with other energy and water related technologies, such as batteries, solar PV, desalination, and heat storage, in many cases reducing costs and environmental impacts of the system.



Hybrid Pumped Storage Hydropower-Battery Storage

Lead authors: Jon Newman (Fluence), S M Shafiul Alam (Idaho National Lab), Thomas Mosier (Idaho National Lab), Quentin Boucher (Supergrid Institute), Elena Vagnoni (EPFL)
Contributors: Mike McWilliams (McWilliams Energy)

Estimated Technology Readiness Level (TRL): 6-7

Key concept

- Combines the long-duration storage of pumped storage hydropower (PSH) with the fast acting, shorter duration capability of other typically smaller energy storage system (ESS) technologies to provide complementary capabilities and services and reduce wear and tear.

Technology brief

HPBS combines the long-duration storage of pumped storage hydropower (PSH) with the fast acting, shorter duration capability of other typically smaller energy storage system (ESS) technologies including battery-based energy storage, supercapacitors, and flywheels, to provide important complementary capabilities and services to pumped storage hydropower (PSH). Hybridization offers three primary benefits to the PSH asset owner, grid operator, and local consumers:

1. Asset revenue boost – By providing faster and more efficient frequency response capabilities, energy storage technologies enhance the asset's ability to provide grid services. Drawing on the flexibility of pumped storage hydropower assets reduces the size requirement of the ESS while maintaining very fast response. PSH Hybridization opens new revenue streams (e.g., from fast frequency response markets) and increases eligible frequency capacity that can bid into grid services markets (e.g., the combined capacity is greater than either standalone asset), unlocking additional value from the HPBS while minimizing investment.⁴⁴
2. O&M cost savings – By reducing starts/stops, ramping requirements, and minimum flow rates to reduce wear and tear, hybridization can lower total PSH operating costs. Further analysis is needed to evaluate and measure the total potential cost benefit to both assets.
3. Grid reliability/resiliency – Energy storage can provide blackstart capability and enable islanding mode, increasing local electricity grid resiliency in the event of a disruption to the grid.

With the increasing penetration of variable generation on the grid, the need for flexibility is accelerating. To support variable renewable energy, PSHs are experiencing changes in their operational demands (e.g., increased ramping requirements). Hybridization provides reliable firm energy and grid services to support the deployment of high penetrations of renewable energy.^{45,46}

Hybridization of energy storage and hydropower itself is not new – conventional and run-of-river hydro reference projects exist which demonstrate the maturity. Additionally, many of the energy storage technologies are commercially available in the market today. For example, lithium-ion battery-based energy storage is a rapidly growing market and grid-scale batteries have been deployed for over a decade.

Challenges, barriers and emerging opportunities

The applications of batteries in power systems are becoming of increasing interest thanks to their decreasing cost (particularly for lithium-ion technologies), high power ramping rates compared to conventional generation units, very high round-trip efficiency and availability with utility-scale MW/MWh sizes. However, their life is an order of magnitude less than a PSH system. In an HPBS, the ESS is controlled to provide fast regulating power, e.g., for primary frequency regulation or grid synchronisation services, whereas the hydropower plant is operated to control the state-of-charge of the battery and to deliver energy and regulation services with slower

⁴⁴ Schreider, Achim, and Ralf Bucher. "An auspicious combination: Fast-ramping battery energy storage and high-capacity pumped hydro." *Energy Procedia* 155 (2018): 156-164.

⁴⁵ <https://www.utilitydive.com/news/kauai-electric-aes-pursue-nations-first-solar-powered-pumped-hydro-projec/593199/>

⁴⁶ Javed, Muhammad Shahzad, et al. "Solar and wind power generation systems with pumped hydro storage: Review and future perspectives." *Renewable Energy* 148 (2020): 176-192.



dynamics. Furthermore, the ESS fast response enables the control of power set-point trajectories for reducing the wear and tear of hydraulic components and minimizes start-and-stop operations, which increases the service time of the hydropower plant and improves its availability.

Beside the clear benefits of this technology, the implementation of HPBS faces several challenges from both technical and economic aspects.

From a market point of view, the participation in fast frequency balancing services, such as grid synchronisation services, is not always remunerated depending on the country and market. This may lead to a low economic interest for the plant owners to invest in hybrid systems. Emerging markets for fast frequency response services help value HPBS capabilities and overcome the economic challenge by allowing their participation.

Furthermore, hybridization would require regulator acceptance of the storage addition to the PSH asset which might encounter some difficulties due to the consequent changes in the participation model, fees, interconnection requirements, etc.

From a technical point of view, control of the ESS and its size should be defined depending as key objectives of hybridization. This may require assessment of risks specific to each site to determine and quantify objectives, e.g., wear and tear of hydroelectric unit components. Original Equipment Manufacturers (OEMs) have insight on these estimations, but it is a challenge to have efficient control of the hybrid HPBS which involves multi-objective functions to find the best asset to optimize the load dispatch between the hydro-units and the BESS. Furthermore, it can be a challenge to model the range of services which can be provided by PSH and HBPS assets, and this causes further difficulties in exploiting all benefits of hybrid technology. The challenges on the HBPS control also lead to some difficulties in determining the optimal size of the ESS (e.g, battery) for both energy and power capacity. It can represent a limitation for the feasibility of the hybridisation of the HPBS as adequate space must be available to place the ESS.

Expanded studies on reference projects and their technical development can be helpful to fully evaluate the financial potential in various markets and cost savings potential of this technology. However, additional work is needed to develop optimal control strategies and the Energy Management System (EMS) for hybrid assets to fully value the benefits of this technology.

Cost-efficacy and feasibility⁴⁷

Pumped storage hydropower and ESS are both mature technologies that are each used regularly in the power system. Globally pumped storage hydropower accounts for 96 percent of the total installed energy storage⁴⁸; in the U.S., for example, there are 22.9 GW of pumped storage hydropower.⁴⁹ There are a few examples specifically of integrated pumped storage hydropower and battery energy storage. These include a solar-battery-pumped storage hybrid plant in development by AES in Hawaii and a 12 MW battery storage system built by Siemens at a pumped storage hydropower facility in Kraftwerksgruppe Pfreimd, Germany.

Integration of pumped storage hydropower and ESS reduces risk associated with and increases performance relative to developing and using first-of-a-kind pumped storage hydropower technologies. Ternary and quaternary pumped storage hydropower are new technologies that enable faster response using a hydraulic short circuit. These technologies likely will have a role in future pumped storage projects; however, batteries and other storage assets such as super capacitors can provide an even faster response. Therefore, an alternative to implementing new pumped storage hydropower technologies is to use pumped storage hydropower technologies with decades of operational history and augment these plants with new ESS assets.

From a cost perspective, pumped storage hydropower plants and battery systems differ by orders of magnitude with respect to cost and lifetime. New closed-loop pumped storage hydropower plants over cost \$1 billion or more but last decades. Lithium-ion batteries, in contrast, can be added as small modules costing on the order of \$1 million each and last less than a decade. Based on these differences in cost and performance, the

⁴⁷ Values in this section are from: <https://www.pnnl.gov/sites/default/files/media/file/Final%20-%20ESGC%20Cost%20Performance%20Report%202012-11-2020.pdf>

⁴⁸ Gür, T. M. (2018). "Review of electrical energy storage technologies, materials and systems: challenges and prospects for large-scale grid storage." *Energy & Environmental Science*, 11(10), 2696–2767.

⁴⁹ <https://www.eia.gov/todayinenergy/detail.php?id=41833>



estimated annualized cost for a pumped storage hydropower plant is approximately \$36/kWh-yr whereas the equivalent cost for a Lithium-ion battery is \$117/kWh-yr today and 85 in 2030/kWh-yr.

Potential beneficiaries & use cases

Hybrid Pumped Storage Hydropower would be of particular interest to:

- PSH asset owners hoping to improve the response time or the frequency response capacity of existing PSP. Hybridization would enable them to access broader revenue streams and increase asset value.
- System Operators could secure large amounts of fast and sustainable reserve while preserving synchronous inertia. These flexible assets would thus increase system reliability and resiliency.
- Governments & Regulators enabling and supporting the implementation of Hybrid Pump Storage Hydropower would promote higher penetration of intermittent renewable energies through environmentally friendly installations.
- Islanded networks and micro grids could benefit from very flexible installation providing all the spectrum of necessary services to weak grids (frequency, voltage and restoration) across all time scales.

Hybrid Pumped Storage Hydropower systems may be particularly suitable to regions benefiting from high shares of intermittent renewable energies where the complementarity of very flexible assets is needed to balance the unpredictable nature of solar and wind generation. Islanded networks with high shares of renewable energies such as Australia, Ireland or the UK are already putting in place fast frequency response markets to procure very fast and reliable frequency response. Such initiatives are particularly suited to hybrid pump storage hydropower.

[Supplementary information can be found in Appendix.](#)



Hybrid Renewable Modular Closed-Loop Scalable PSH System

Lead authors: Hector Medina, PhD and Thomas Eldredge, PhD

Estimated Technology Readiness Level (TRL): 3

Key concept

- PSH concept using bladder-type tank reservoirs
- Modular and scalable (1-10 MW) PSH
- Easily deployable in many terrains and configurations

Technology brief

The patent-pending technology focuses on a concept described as “hybrid, modular, closed-loop, scalable pumped storage hydro (h-mcs-PSH) and renewable” system with an approximate power capacity range of 0.1 to 10 MW (although larger capacities can be attained). A depiction of the said concept is shown in Figure C2-1.

The *hybrid* aspect of this technology refers to the incorporation of renewable energy generation, which serves the purpose of increasing the effective energy efficiency of the system and adding extra energy to the grid. The use of solar panels is preferred in some cases since it could add an extra benefit of UV protection to the polymeric reservoirs.

The *modularity* allows for fast fabrication and assembly of the system.

The *closed-loop* aspect is meant to decrease the level of invasiveness into the environment and facilitate deployment in locations with no existing bodies of water; it also provides a means to conserve water resources. The polymeric reservoirs are typically closed, which essentially eliminates evaporative losses.

The *scalability* attribute allows the installed capacity to be varied based on the application or need. The h-mcs-PSH system was devised with an emphasis on reducing equipment and civil works costs, while expediting the timeline for project commissioning. Original funding was made possible through the United States’ Department of Energy⁵⁰. Currently the concept is under detailed study. More specifically, small-scale testing, robust computational simulations, and detailed cost analysis are being conducted⁵¹. A pilot-scale (100kW) is being pursued in collaboration with partners in the southwest region of the Commonwealth of Virginia, U.S., with the goal of implementation in the next two years aiming to bring this technology to full maturity and commercialization.⁵²⁵³

Challenges, barriers and emerging opportunities

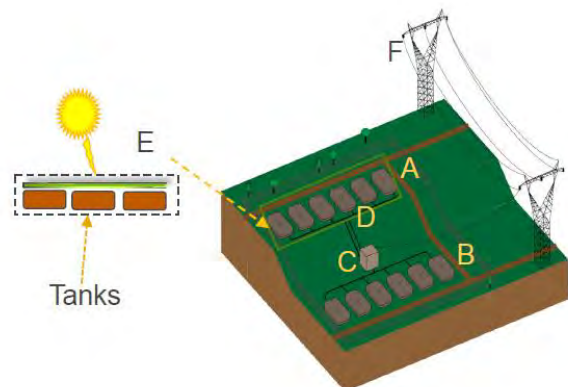

- A= Upper reservoir
- B = Lower reservoir
- C= Powerhouse (well pump)
- D = Penstock
- E = Solar panels
- F = Transmission lines

Figure C2-1: Illustration of h-mcs-PSH system

⁵⁰ Department of Energy, “Energy Department Announces the Grand Prize Winners of the FAST Prize Competition”, October 8 2019. www.energy.gov. Last visited on March, 10, 2021.

⁵¹ Small-scale testing includes fatigue testing of bladder tanks. Experimental work also includes membrane’s fatigue testing, hydrolysis and ultraviolet degradation of membrane material. Computational simulations include fatigue on membrane as well as penstock, water hammer effects and frequency analysis on the penstock via two-way fluid-structure interactions. Analytical work includes hyperelastic modeling of membrane material as well as modeling membrane stress behavior of filled bladder tanks via coupling membrane curvature and fluid pressure.

⁵² Hadjerioua B, Eldredge T, Medina H, DeNeale S. Hydrodynamic and Structural Response Modeling of a Prototype Floating Membrane Reservoir System for Pumped Storage Hydropower. *Journal of Hydraulic Engineering*. 2019 Jul 13;145(9):04019032.

⁵³ Hadjerioua, Boualem, Eldredge, Thomas, Medina, Hector, and Deneale, Scott T. “Design and Modeling of a Prototype Floating Membrane Reservoir System Application for Pumped Storage Hydropower”. ASCE EWRI Congress, Pittsburgh, PA, May 2019.



The h-mcs-PSH concept is not intended for very large capacities (more than 20MW), therefore it will not be attractive for single large traditional PSH projects. However, the range capacity can be attractive to industrial, academic campuses, and community projects with sufficient head potential.

The main barriers for implementation could be associated with overcoming the mindset of traditional PSH and accepting novel and disruptive technologies such as the h-mcs-PSH. The opportunities for the use of the h-mcs-PSH system are based on its primary benefits, which include the following:

- Easily deployable in many terrains and locations.
- Very minimal civil works.
- Polymeric tanks can be extremely low maintenance, yet durable, reliable, and long life.
- Closed loop system, which reduces environment invasion and conserves water resources.
- Low cost, in \$/kW (see Figs. 2-3 in Appendix) and estimated 20+ years of life.
- High efficiency vertical-shaft pump-turbine system, which does not require sub-terrain pump-turbine building.
- Solar or other various renewable energy resources can be incorporated.
- Potential for expedited or exempted FERC (Federal Energy Regulatory Commission) licensing, as described below.

Cost-efficacy and feasibility

For the proposed system, as with most pump storage technologies, there are relationships between available the elevation head, reservoir volume, and the generation capacity. These factors affect the system design, such as the penstock piping, number of pipes, number of reservoir tanks, and the pump-turbine characteristics. Table 1 in the Appendix shows the cost breakdown between major components of the system without renewables included. As shown, the reservoir tanks represent a significant fraction of the total installed cost, and this fraction increases with increasing generation capacity. Following, our technology is compared against traditional PSH as well as Li-ion batteries.

Lithium-ion batteries have a life up to about 10000 cycles. Based on two cycles per day, lithium-ion batteries have a life up to 13.7 years. The h-mcs-PSH system has an estimated life of at least 20+ years. The cost of the proposed h-mcs-PSH system is approximately equivalent, and in some cases lower than lithium-ion batteries, and the life of h-mcs-PSH is approximately two to three times longer. This results in the h-mcs-PSH system being more cost effective and marketable than lithium-ion batteries.

In addition, on average, in order for conventional PSH projects to end up costing below \$3,000/kW, the installed capacity must exceed 600 MW. Based on estimated cost analysis, the h-mcs-PSH is more economically attractive than the average conventional PSH project on a \$/kW basis. Furthermore, when the renewable component is included, although the capital cost slightly increases, the overall benefit is enhanced due to the extra energy generated, which can be invested in the system itself or provided to the grid. See Figure. 2 in Appendix. (Note: A flowchart detailing how size and number of main components were determined is shown in Fig. 4.)

Potential beneficiaries & use cases

The h-mcs-PSH system is modular and scalable for sizes in the range of 0.1 to 10 MW, and it does not rely on natural bodies of water being present. The h-mcs-PSH system can be attractive to industries that require relatively large amounts of electricity, including the manufacture of aluminum, steel, plastics, and paper. Often these industries generate a portion of their own electricity.

Using h-mcs-PSH, industries can optimize their electricity consumption and provide demand response. In addition, this technology is highly suitable for small island grid systems and for isolated and remote systems around the world.

[Supplementary information can be found in Appendix.](#)



Integrated Pumped Hydro Reverse Osmosis Clean Energy System (IPHROCES)

Lead author: Joan Leal, Oceanus Power & Water

Contributors: Maha Haji, Cornell University

Estimated Technology Readiness Level (TRL): 7

Key concept

- PSH plant uses surplus grid electricity or onsite RE generation to pump seawater into upper reservoir.
- Simultaneously providing clean energy generation, energy storage, and freshwater.

Technology brief

The Integrated Pumped Hydro Reverse Osmosis Clean Energy System (IPHROCES) integrates three proven technologies: Seawater Pumped Hydropower Energy Storage (SPHES), Seawater Reverse Osmosis (SWRO) and renewable energy into a single facility, simultaneously providing clean energy generation, energy storage, and freshwater. Oceanus is an infrastructure development company focusing on delivering water and energy security. IPHROCES offers several economic and environmental benefits in comparison to traditional, separate SWRO desalination and SPHES facilities.

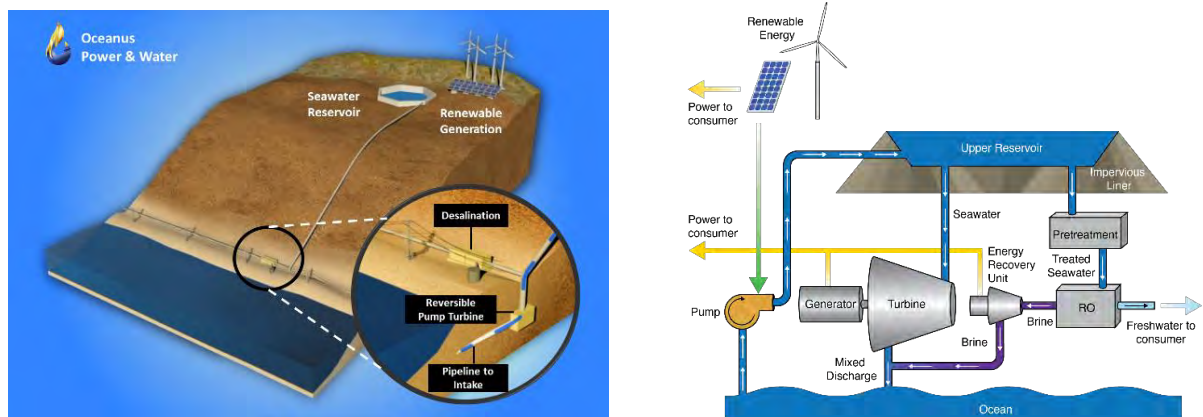

Figure C3-1: IPHROCES concept.

Seawater is pumped into the upper storage reservoir using conventional hydropower technology, typically reversible pump-turbines, using surplus electricity from the power grid or onsite renewable generation. When required, this water is released downhill, driving the pump-turbines in generation mode and producing electricity. The water in the upper reservoir is also discharged using a standalone pipeline to feed the desalination plant as desired, taking advantage of the pressure provided by the water column's elevation. This hydraulic pressure eliminates the need for additional electricity to be provided to drive the SWRO desalination facility.

Collocation of the systems further helps to reduce overall cost because typically, twenty times as much water will be released to the power generation turbines as to the desalination plant, and the turbine discharge can thus be used to dilute the desalination system's brine outflow. This eliminates the need for a costly brine outflow pipe and pump system.

Hydro Pumped Storage provides more than 96% of all installed energy storage capacity globally. Current global capacity of desalination is 100 million m³/day, with more than 300 million people getting freshwater from 20,000 plants in 150 countries. While there are many freshwater pumped hydro plants in operation, it is often difficult to site a new plant because of geography, population pressure, and scarcity of fresh water in many locations. The oceans, however, represent an essentially infinite lower reservoir in coastal locations where there are nearby mountains. Only one pumped seawater hydro plant has been built, the 30 MW Yanbaru plant in Japan, which was supplied with excess power from the grid, and it was successfully operating for nearly 20 years and only recently has stopped operation for commercial, not technical reasons.



Oceanus is currently developing a large scale IPHROCES facility in South America. The project includes a large SWRO desalination facility and a seawater pumped hydro energy storage (SPHES). The IPHROCES technology is a proprietary process, patented by Oceanus. The Technology Readiness Level (TRL) scale of IPHROCES is considered to be TRL 7.

Challenges, barriers and emerging opportunities

Integrated pumped hydropower and reverse osmosis systems require co-location to achieve necessary efficiencies, utilize sustainable power sources for pumped hydro storage applications and reduced capital investment in the plant, equipment, and brine diffusion process. These integrated plants best serve communities seeking a reliable, sustainable, and cheap power source as well as freshwater supply for populations, agriculture, and industrial uses. However, the topography further limits operations as the water source must be optimally located within 4 km of the reservoir, and the reservoir must have a 400 m elevation change from the desalination and hydropower plant. Also, the local geology and marine conditions need to be favourable to build and operate the main project components: Intake-outlet facility, powerhouse, penstocks, reservoir, and desalination buildings. In addition, the use of seawater for the overall process requires a detailed analysis on corrosion, abrasion, and biofouling for the specific locations of the projects.

A brief description of each benefit as compared to typical, stand-alone solutions is as follows:

- **Economic:** lower cost water production and lower cost energy storage services
- **Environmental:** reduced emissions, reduced energy required, and reduced impact on the natural environment, both due to reduced mining of battery components and reduced impact on the marine environment from brine disposal. The co-location of a SPHES facility, with large seawater discharge flows, provides a source for dilution of brine concentrate created by the SWRO Desalination facility.
- **Resilience:** increased predictability and reliability of water supply and long duration storage of renewable energy generation (more than 6 hours/day).
- **Economic impact and sustainability:** IPHROCES projects create a wide range of enduring jobs and local economic benefits. The IPHROCES solution can help achieve more than 5 of the United Nations (UN) Sustainable Development Goals.

The business plan of IPHROCES is supported in the regulatory framework of the regions to be implemented. On the power side, regulations for energy storage and the services to be commercialized such as, energy sales, capacity, and ancillary services. In addition, clear regulatory framework on the use of seawater is required (maritime concession, usage fees, others). Since IPHROCES requires infrastructure development to be implemented, well defined and transparent environmental and social permitting processes are needed to advance the projects towards construction and operations.

Cost-efficacy and feasibility

IPHROCES combines existing, bankable technologies to achieve a level of economic and environmental performance that is unattainable as individual facilities. IPHROCES provides the following benefits:

- Capital cost savings due to sharing of seawater intake/outflow structures, pipelines, electrical grid connection and ancillary buildings; project planning, contracting, permitting, and financing.
- Operating cost savings with low-cost energy rates, and shared staffing.
- Effective use of intermittent energy sources needing fast responding and load shifting energy storage; deployment hydraulic energy to drive the RO desalination process by eliminating high-pressure pumps and reducing the energy required in the RO process.
- Optimization of proven technologies including pump-turbines, motor-generators, penstocks and reservoirs, pressure exchange turbochargers, and solar and wind generation facilities.
- Climate resilient source of potable water produced at a lower cost than typical desalinated water and long duration energy storage services delivered at one of the lowest LCOS rates on the market today compared to similar but stand-alone technologies.

The integrated facility has the longest life-cycle of other standalone reverse osmosis and energy storage (i.e., chemical and mechanical) systems. The renewable energy, energy storage, and water sectors are crowded by privates and public companies generating energy and producing freshwater worldwide. Chemical battery (e.g. Lithium-ion) development is making significant progress, yet it is not feasible for large scale or long duration storage; is environmentally destructive; and is not economically feasible, especially when considering lifecycle



costs. Energy embodied in constructing storage facilities is more effective than for battery manufacturing. Desalination has also advanced along a typical technology innovation pathway, but neither disruptive energy reductions nor environmental improvements have been forthcoming.

The differentiating factor of IPHROCES projects is the integration of desalination that brings significant environmental, technical and economic benefits, providing the low cost of energy and water of the market. IPHROCES projects are site specific and need a great understanding of the local site condition of the proposed sites including geology, oceanography, seismicity, and others. Also, the integration is only feasible under specific site conditions: elevation, local topography and bathymetry, local climate, water quality, and others. The major technical risks of the project are related to the site selection and the understanding of the natural conditions of the site. The development of the project depends on the progress of the permitting, engineering design and contracts. One of the relevant obstacles during the development phase is the permitting process associated with the environmental application. Also, project financing of a single unit could present risks if the value of the integration is not studied properly.

Potential beneficiaries & use cases

IPHROCES can commercialize desalinated water through a water purchase agreement structure to either municipal water utilities or industrial water customers, such as a mine. The system can also commercialize energy storage services and power through a combination of merchant market transactions and power purchase and sale agreements with municipal or commercial energy companies. IPHROCES can scale from small island or microgrid level needs up to a full utility scale, regional need and will aid communities increase their climate change resilience. Additionally, the IPHROCES solution reduces the negative environmental impact of typical reverse osmosis desalination while concurrently accelerating the transition to zero carbon energy sources. The concept can be replicated in locations where there are physical and market conditions critical for successful IPHROCES solutions: drought-prone regions with high growth of intermittent renewables in need of grid stabilization assets as fossil-fuel based power plants are being decommissioned.

[Supplementary information can be found in Appendix.](#)



Solar PV hybrids

Lead authors: Marine Bernicot (ISL Ingénierie), Bente Brunnes (World Bank), Zuzana Dobrotková (World Bank), Surbhi Goyal (World Bank), Prof Arun Kumar (Indian Institute of Technology, Roorkee), Akshita Gupta (Indian Institute of Technology, Roorkee)

Contributors: DMR Panda (NTPC Ltd), BP Rao (NHPC Ltd), P.M. Nanda (GREENKO), Shreedhar Singh (SECI Ltd).

Estimated Technology Readiness Level (TRL): 6-7

Key concept

- Coupling PSH with solar to provide dispatchable power with low costs and minimal environmental impacts, especially for smaller or weaker grids.

Technology brief

This brief describes hybridization of solar photovoltaic (PV) technology and pumped storage hydropower (PSH) plants to maximize benefits of both technologies while removing some of their drawbacks thanks to hybridization which in this context means floating the PV resource on the PSH reservoir. (For the rest of the brief these hybrids are referred to as solar-PSH hybrids.)

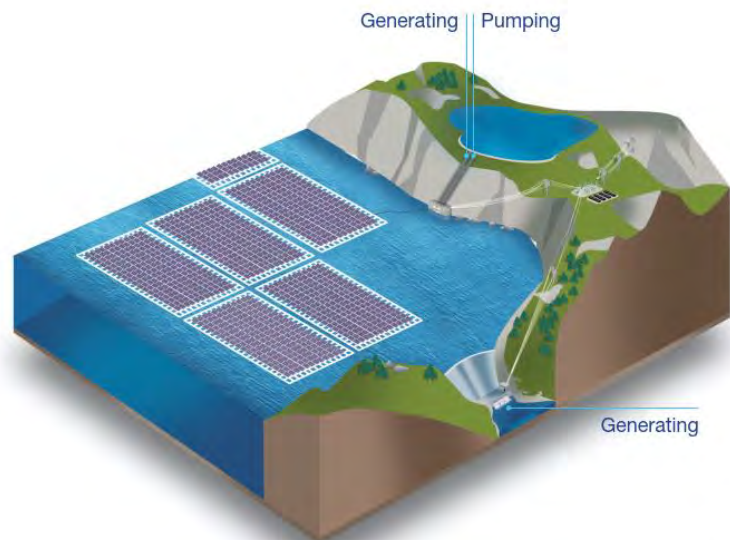

Figure C4-1: PSH-solar hybrid plant. Note that the figure depicts one possible configuration of PSH-solar hybrid but other configurations are possible (e.g. with closed-loop PSH and no release of water downstream, or with land-based solar).

By hybridizing solar and PSH plant we can create a single source of energy that is completely renewable. The PSH provides storage at the scale of sub-minutes, minutes, hours and in certain cases even days, depending on the size of the reservoir and at competitive costs.

Solar today is characterized by very low and still decreasing costs, fast construction and low environmental footprint but its main drawback is the variability of output, including no availability at night. This implies a need for storage associated with solar, in particular in smaller or weaker grids. Hydropower, on the other hand, is one of the most flexible resources available to ensure grid's stability in all time scales. This flexibility is further enhanced by pumped storage plants ability to return water back into the reservoir and use the same water to generate electricity when needed in a closed loop system.

With turbine pumping station connected with a solar farm (land-based or floating), solar output can be injected to the grid and used for pumping to store water (depending on the configuration of a given plant, only "excess" solar that cannot be absorbed by the grid and would be curtailed is used for pumping or solar plant can be dedicated exclusively for pumping). Traditional hydropower release water to produce energy, however it is limited by the schedule of other water uses, such as irrigation. This limits hydropower development in water-scarce situations. Solar-PSH hybrid takes advantages of both solar and PSH technologies: solar can produce energy at low cost while PSH brings flexibility and dispatchability, without having to release water downstream, thus alleviate the constraints of water availability (Deroo et al. 2018).

Additionally, the use of common infrastructure such as power line from the plant and substation is optimized by connecting the two plants to the same infrastructure, decreasing per unit costs. Other benefits of solar-PSH hybrids include decreased evaporation in case the solar plant is floating. Floating solar plants are also assumed to have positive impact on water quality in the reservoir, provided they only cover minor part of the reservoir,



but this effect needs to be studied in detail for every given plant.⁵⁴⁵⁵ Hybridization of PSH with solar can therefore bring many desired benefits to power systems as well as water uses at very low costs and, under thoughtful design, also with minimal environmental impacts.

The concept of solar-PSH hybridization has been described in literature for multiple years now⁵⁶⁵⁷⁵⁸ however there is no solar-PSH hybrid project under operation yet. In India, Pinnapuram 1200 MW PSH project with 9 hours storage is under execution and expected to be commissioned by 2023 along with 80 + 80 MW (upper + lower reservoir) floating solar, 3000 MW land-based solar and 500 MW wind energy as a result of a January 2020 peak power supply tender. There are more than ten floating solar projects being executed in India by central power utilities in India with cumulative capacity of about 1500 MW. Many of the water bodies are part of hydro reservoirs.

Challenges, barriers and emerging opportunities

Solar-PSH hybridization can be hampered by several physical and technical issues but also by regulatory barriers:

- physical and environmental conditions must allow for construction of a PSH plant associated with a reservoir, or a PSH plant must be already built;
- addition of a solar plant of the necessary size for the optimal operation may not always be possible (e.g. land for solar construction next to PSH is not available or is protected, or size of the reservoir is too small for a floating installation, etc.);
- for floating solar installation there are risks related to the relative new nature of the technology (e.g. durability of floats, panels and wiring in aquatic conditions).
- Anchoring and mooring of floating installations can be complex and costly in deep reservoirs, trash and sediment handling, and/or with high water level variations and surface wave – these risks and costs need to be taken into account in the design (and can be completely avoided by land-based solar);
- in case of failure of anchors for a floating installation, incident could result in a spillway obstruction;
- in many jurisdictions it is unclear who owns the water surface if floating solar is considered, or there can be other ownership issues among multiple users of the reservoir. It is also often unclear how a solar-PSH hybrid plant would be permitted, licensed and remunerated – resolving all of these issues can significantly slow down developments;
- in certain countries operators of PSH have no capabilities/experience in operating of solar plants but complex institutional structuring involving 2 different operators can lead to misaligned incentives for a hybrid operation or very complex contractual arrangements.
- The availability of standard technical specifications for materials of floats, mooring & anchoring, cables, solar panel technology and balance of plant etc. is a challenge.

Next steps towards adoption:

- governments need to create a clear regulatory framework under which solar-PSH hybrid plants (or solar-hydro hybrid plants in general) can be permitted, licensed and remunerated;

⁵⁴ World Bank Group, ESMAP and SERIS (2019a), "Where Sun Meets Water: Floating Solar Market Report"

⁵⁵ World Bank Group, ESMAP and SERIS (2019b), "Where Sun Meets Water: Floating Solar Handbook for Practitioners"

⁵⁶ L. Deroo, B. Peltié, H. Meurisse, S. Amazzal (2018), "Solar-Hydro: hydropower production and storage from solar energy with competitive cost"

⁵⁷ L. Deroo, Y. Sahut, B. Defrance (2021), "Solar-hydro: a new utilization of dam reservoirs"

⁵⁸ M. Bernicot, J. Partiot, L. Deroo (2019), "Hydro-solar: A storage solution for solar energy with competitive cost"



- solar as part of the solar-PSH hybrid plants needs to be designed to minimise environmental impacts while keeping down the cost of solar (e.g. prefer land-based solar to more expensive and complex floating solar, if local conditions allow for land-based option);
- first solar-PSH hybrid plants need to prove real-life benefits of such installations for water/hydro owners as well as for energy systems and, in case of floating solar installations also demonstrate, through monitoring and evaluation of reservoir data, environmental sustainability of such hybrids – these first experiences need to be documented by impartial parties and lessons should be widely shared;
- first solar-PSH hybrid plants should be encouraged in places where the same owner can operate both PSH and solar part of the plant for optimal operation, easier licensing and minimization of institutional structuring obstacles.
- Creation of a shelf of floating and territorial solar PV hybrid PSH traditional, off river projects and non-traditional sites, be taken up immediately by the stakeholders to reduce the implementation time and scaling up the technology.

Cost-efficacy and feasibility

Installation costs of solar-PSH hybrids have recently become competitive because of ever decreasing cost of solar, but also due to advances in floaters for floating solar technologies, needed for certain hybrid installations. Costs of power electronics including pumps & turbines with variable speed have also decreased. Depending on the context and the constraints, the installation cost of the full hybrid plant varies today from 1 to 3 € / W installed (2018 costs), the pumped storage powerplant being a key component of the overall cost.

1 ha of reservoir can typically host about 1 MWp of solar power and 0.2 to 0.5 MW of hybrid solar-hydro power that produce more than 1.5 GWh/year of on-demand electricity at around 80 to 200 €/MWh (the upper part of this range reflects remote or off-grid plants).⁵⁹ Even if such a system has very low operating costs during the whole lifetime of the installation and produces electricity at a high load factor, the initial investment (CAPEX) still remains high and can be an obstacle for initial investment. On the other hand, solar-PSH can help financing projects strategic for development overall, such as irrigation or water supply, by adding an economic and profitability perspective.

Potential beneficiaries & use cases

Solar-PSH hybrids are of biggest interests to power systems with large needs for energy storage, such as systems lacking other types of flexible generation, as well as for weak or off-grid systems that are facing a rapid scale up of variable generation from solar and wind (e.g. several systems in sub-Saharan Africa). Solar-PSH hybrids are particularly suitable for places with water scarcity (whether a generalized scarcity or a recurring scarcity during dry season) since they can create hydropower without “consumption” of water⁶⁰.

⁵⁹ L. Deroo, B. Peltié, H. Meurisse, S. Amazzal (2018), “Solar-Hydro: hydropower production and storage from solar energy with competitive cost”

⁶⁰ L. Deroo, B. Peltié, H. Meurisse, S. Amazzal (2018), “Solar-Hydro: hydropower production and storage from solar energy with competitive cost”

Thermal Pumped-Storage Hydropower

Lead authors: Franz Georg Pikel, Wolfgang Richter and Gerald Zenz, Graz University of Technology, Austria

Estimated Technology Readiness Level (TRL): 5

Key concept

- Combines PSH with underground thermal energy storage to create closed-loop and underground 'Hot-water PSH'.

Technology brief

The Thermal Underground Pumped-Storage Hydropower (TUPH) system (Figure C5-1) is a new concept triple-storage technology for energy capacity balancing and generation of electricity and thermal energy. With the combination of existing technologies, it has the potential to provide clean energy for energy-efficient supply of multiple sectors with power, heating and cooling.

Water is a clean resource for hydroelectric energy storage and water features best characteristics for thermal energy storage as well. Besides the need of sufficient energy storage capacities for the eco-friendly electricity supply, also thermal energy storage systems are indispensable for the renewable shift for carbon-free heating and cooling. Large-scale and very efficient thermal energy storage systems use water as energy carrier in caverns.⁶¹ TUPH is a synthesis of the mature and proven pumped-storage hydropower and thermal energy storage technology in one integrated system that combines best existing technologies for a durable economic, social and environmentally-friendly energy transition.

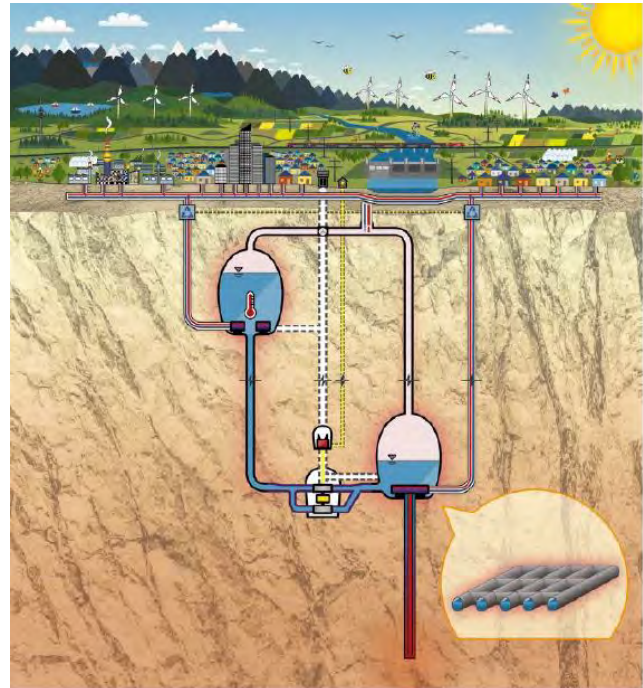

Figure C5-1: Illustration of TUPH system

TUPH is a fully underground, closed-loop hot-water pumped-storage scheme with vertically separated reservoir caverns connected via a pressure shaft to pumped-storage units for multi-hour electrical energy storage. In order to store thermal energy at the same time, the water of the underground pumped hydro system is heated by means of heat exchangers, linked with thermal energy producers, waste heat suppliers, district heating systems and renewable heat sources via heat transmission lines. Water temperatures reach up to 95°C in the seasonal cycle of buffering thermal energy. The stored thermal energy serves for district heating and cooling networks as a flexible back-up capacity for the resilient heating, cooling and hot water supply, improving demand elasticity. A TUPH unlocks the total energy storage capacity of water in one system to store more than 20-30 times the energy capacity in a conventional pumped hydro storage system in one cycle.^{62,63}

⁶¹ Brunström C, Hillström CG (1987): The Lyckebo project, solar district heating with seasonal storage in a rock cavern.

⁶² Pikel FG et al. (2020): TRI-STO-GEN. Submission documents for the Helsinki Energy Challenge.

⁶³ Pikel FG (2017): Pumped-Storage Hydropower combined with Thermal Energy Storage. Master's thesis. 260 p. Graz University of Technology. (in German)



Table C5-1: TUPH case study with the combined energy storage capacities for a 500 MW_P, 8-hour cycle power plant (800 m hydraulic head, 2 million m³ water) and a heat capacity of 400 MW_H ⁶⁴

	Energy Storage Capacity (one cycle)
	[MWh]
Power	4 000
Heat	95 000

Notably, PSH systems typically have about 80% roundtrip efficiency, where the 20% energy is dissipated. With TUPH, every pumped-storage cycle (e.g. daily) helps to heat the water in the reservoirs by the dissipated energy during pumped hydro operation. Thermal conversion caused by friction of turbinning and pumping is directly absorbed by the water and stored in the closed-loop system for 90%+ total system energy-efficiency. The sector-coupling design integrates this new thermal energy source for low grade heating needs such as hot water and HVAC systems.

The TUPH concept has been developed by Piki FG and is under continued optimization at Graz University of Technology in Austria. ⁶⁵The authors have published various papers and conducted several case studies for this innovative energy storage.

Challenges, barriers and emerging opportunities

The TUPH concept can be implemented independently from existing infrastructure, close to cities and load centres. Best connection to power grids and heat networks allows balancing of various renewable electricity and thermal energy generation sources and clean, emission-free energy supply. The core parts of the TUPH facility are built fully underground with no limitations of the topography and a comprehensive protection of natural resources and at least no impact on the landscape. The easy and cost-effective scalability and adaption of power output as well as energy storage capacity to balance intermittent supply and demand situations for multiple energy markets ensure economic reliability and system security in the long-term.

However, an appropriate geology with suitable rock conditions is key for an economic construction and safe long-term operation, but the underground offers a naturally protected environment with unlimited space. Complexity is added by the deep underground excavation but is a controllable project risk and is considered for the cost breakdown of a TUPH case study in the appendix.

The use of hot water for pumped-storage operation is new, but does not affect the basic principle of hydroelectric energy storage. However, the technical feasibility of hot-water driven pumped-storage requires a hydraulic redesign and structural adaptations where in addition to mechanical affects, the potential for formation of bacteria films and consequences of water treatment to prevent them will need to be investigated. The fact that there is significant experience in district heating systems gives sufficient practical reason that these issues can be addressed.

The TUPH concept interconnects energy technologies from different sectors. Thus, enhanced business models with cross-sectoral power plant operation and efficient renewable energy management need to be developed for optimal system performance. For example, large-scale heat pumps are predestined for heat conversion via efficient power-to-heat as cross-sectoral use of power, heating and cooling.

One of the innovation anchors is the breakthrough in energy-efficiency, an indicator for cost and resource-efficiency, for societal effects and socio-economic factors. The maximized energy output compared to the energy invested (EROI/ESOI) results in a higher quality of life, welfare and health and fully fits with the UN sustainable development goals.

⁶⁴ Piki FG et al. (2020): TRI-STO-GEN. Submission documents for the Helsinki Energy Challenge.

⁶⁵ Piki FG (2017): Pumped-Storage Hydropower combined with Thermal Energy Storage. Master's thesis. 260 p. Graz University of Technology. (in German)



Cost-efficacy and feasibility

An applied recycling of suitable rock from the underground excavation by a soft geoengineering technology can make the system fully carbon-neutral too: During the accelerated weathering of the crushed rock, it captures all carbon dioxide emissions from the system's implementation out of the atmosphere and locks it away [4,5,6,7]. The total carbon dioxide emissions for the 500 MW_P and 400 MW_H TUPH case study are about 225,000 tons, considering all life-cycle emissions of the resources utilized with safety factors. Only 5.5% or 276,570 m³ of excavated rock for the underground facility has the potential to remove all of these CO₂ emissions from the air to store it in the weathered rock ⁶⁶.

From an investment point of view the power and energy capacity CAPEX for the underground triple-storage facility are about 1000-1600 EUR/kW (related to the power plant and heat capacity) and about 5-15 EUR/kWh (related to the sum of single cycle energy-storage capacities of electricity, heating and cooling). The cost breakdown for a TUPH case study is provided in Figure 2 in Appendix. The planning reliability, the combination of various business models with multiple and stable revenue opportunities ensure a high-level investment security without the dependency on fuel costs, fuel taxes and CO₂-emission allowance prices. The energy carrier water is a natural and an easily available resource at very low cost. Additionally, the underground energy storage is protected from evaporation and sedimentation.

A main objective of the multipurpose energy storage system is to ensure long-term affordable energy and competitive prices for the country, energy end-users and the industry.

Potential beneficiaries & use cases

The target audience for the TUPH system are governments, communities, system operators, utilities and private investors. The TUPH can be integrated as an upgrade for existing energy systems, but is also a key part for an overall system change in energy supply powered by renewables and clean technologies. The modular, adaptable and flexible design offers the possibility to fit all energy system situations in the vicinity of urban environments for a global implementation feasibility.

[Supplementary information can be found in Appendix.](#)

⁶⁶ Piki FG et al. (2020): TRI-STO-GEN. Submission documents for the Helsinki Energy Challenge

Appendix

The following section contain supplementary information provided by authors, such as tables, diagrams, references and graphs.



Supplementary information - Location Agnostic Pumped Storage (LAPS):

Appendix A: Characteristics of Basic LAPS Scheme

Parameter	Characteristic
Installed capacity	1000 MW
Energy storage	8000 MWh (8 hours of generation / 10 hours of pumping)
Gross head	1400 metres
Surface footprint	20 ha
Water storage	2.4 million cubic metres
Surface reservoir area	~12 ha
Lower reservoir	47 km of 8.0 m diameter TBM bored tunnel
Pumped-storage units	Pelton ternary units with multi-stage pumps and hydraulic short circuit
Scheme cycle efficiency	~80% (90% generating, 89% pumping)
System regulating range	2000 MW (1000 MW injection; 1000 MW absorption)
Zero (spinning) to pumping or turbining	Less than 30 seconds
Change from pumping to turbining (and v-v)	Less than 30 seconds

Appendix B: Schematic of LAPS and construction sequence

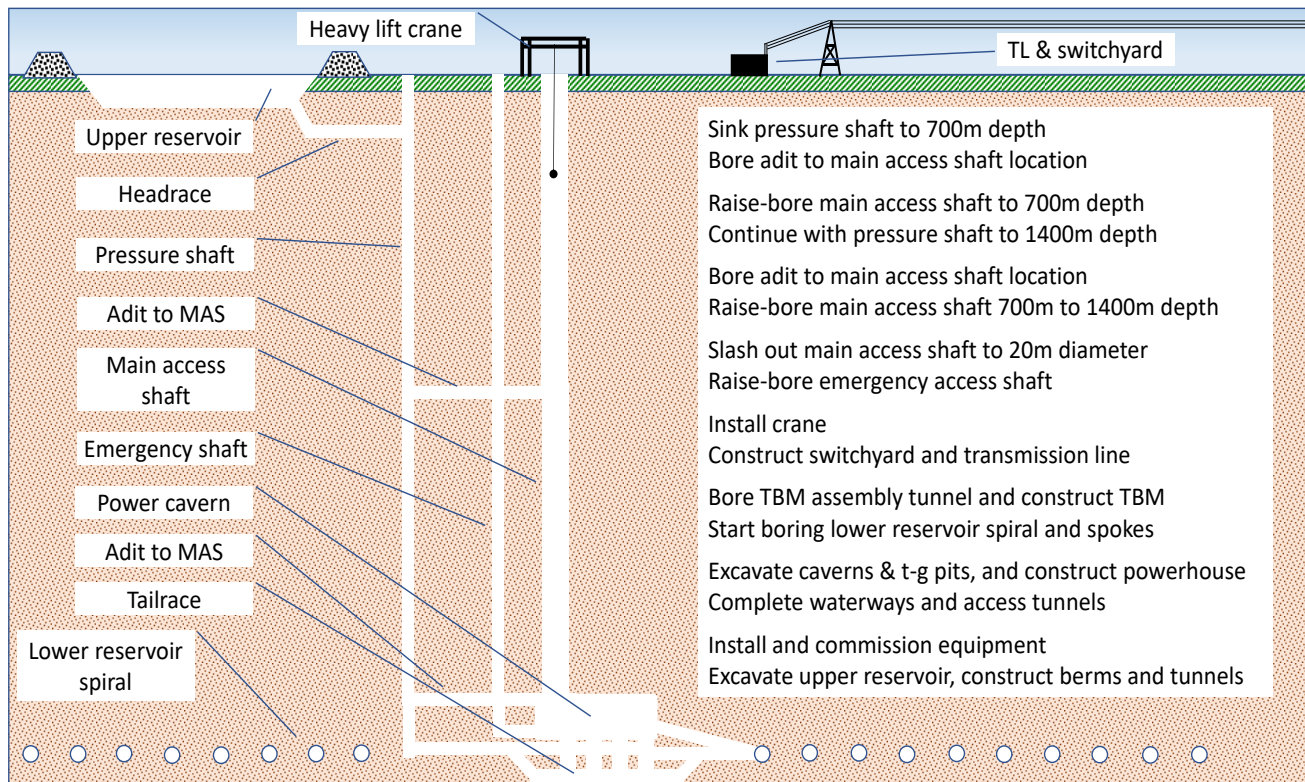



Appendix C: Layout of LAPS Scheme at surface and at 1400m depth

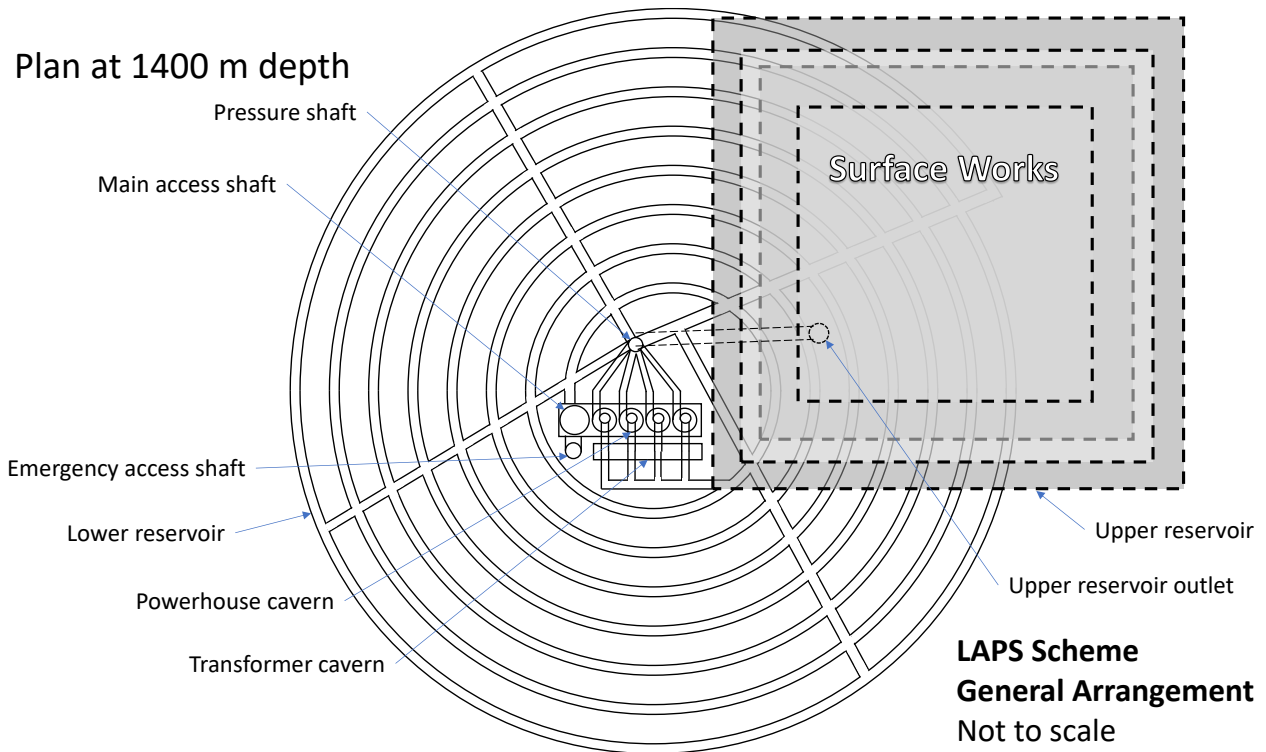

Appendix D: Construction schedule

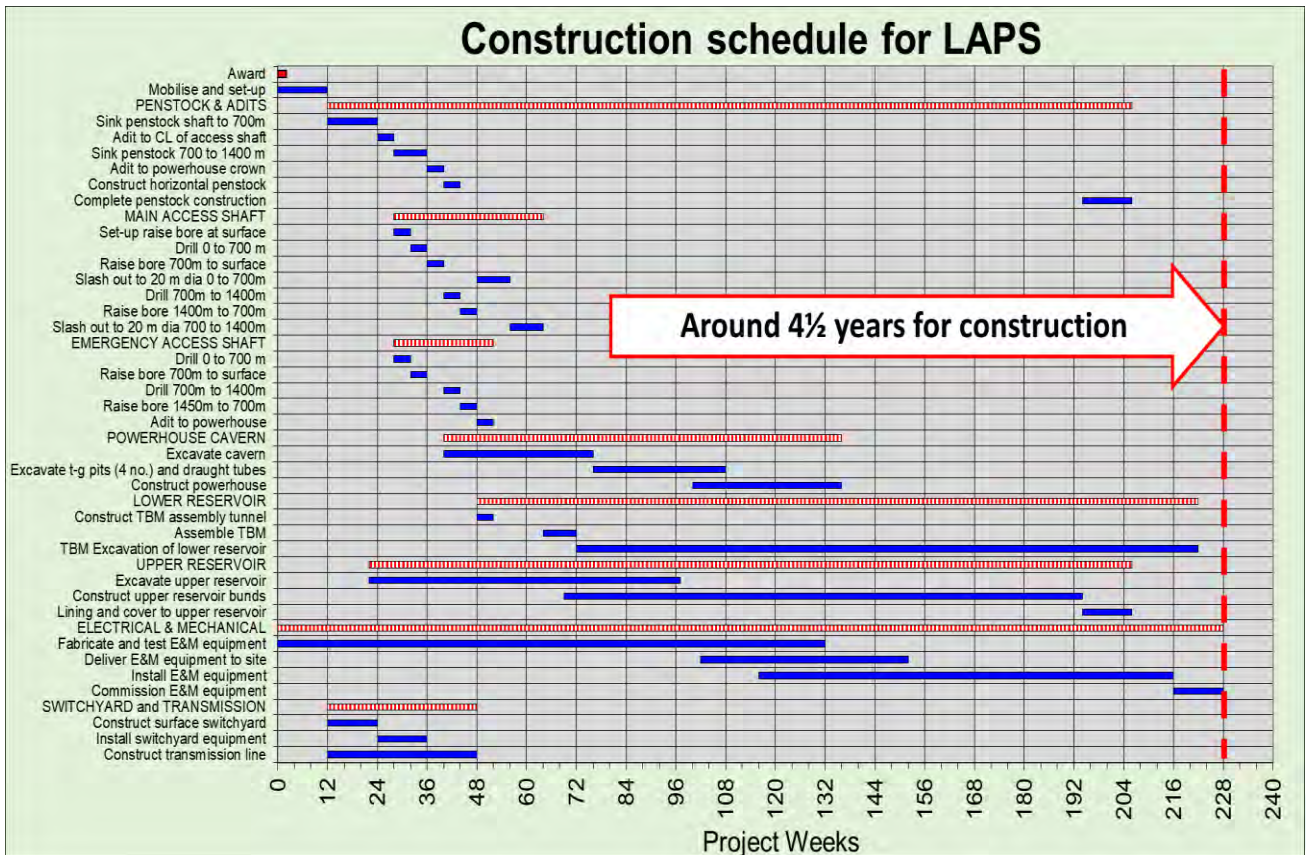



Appendix E: Construction cost estimate (Class 5) of 1000 MW / 8000 MWh LAPS scheme at 1400 m

Item	Cost (USD)
Mobilisation	\$ 45m
Surface works	\$ 70 m
Underground civil works	\$845 m
Powerhouse equipment	\$200 m
Switchyard and transmission	\$20 m
Unmeasured items	\$240 m
Contingencies	\$280 m
Total EPC cost	\$1,700 m
Developer's costs	\$500 m
Total project cost (excluding IDC)	\$2,200 m
Cost per kW of capacity	\$2,200 /kW
Cost per kWh of energy storage	\$275 /kWh
Marginal cost of varying energy storage	\$175 /kWh



Supplementary information - Seawater Pumped Storage System

Case study for the island of Curacao

The saltwater pumped storage study made for the island of Curacao estimates the need for the regulation energy achieving the stable grid under current conditions and for the forecast energy needs in 2030 when a big portion of the energy should come from renewable sources, wind and solar. For these scenarios daily energy demand and supply have been defined for each month and the amount of regulation energy has been defined. The study showed that the maximal required power is 22 MW and a daily regulated energy of 135MWh is needed.

With help of GIS software, the potential sites for reservoirs formed by a dam in the valley (dry gully type reservoir) and formed by ring dam on the planes (turkey nest reservoir) with required volume for the given head are defined. The potential sites are then ranked based on the needed dam volume and the ratio between the total head of the site and the distance from the sea, considering also areas with environmental and social restrictions. These criteria have been used for the selection of the most promising sites.

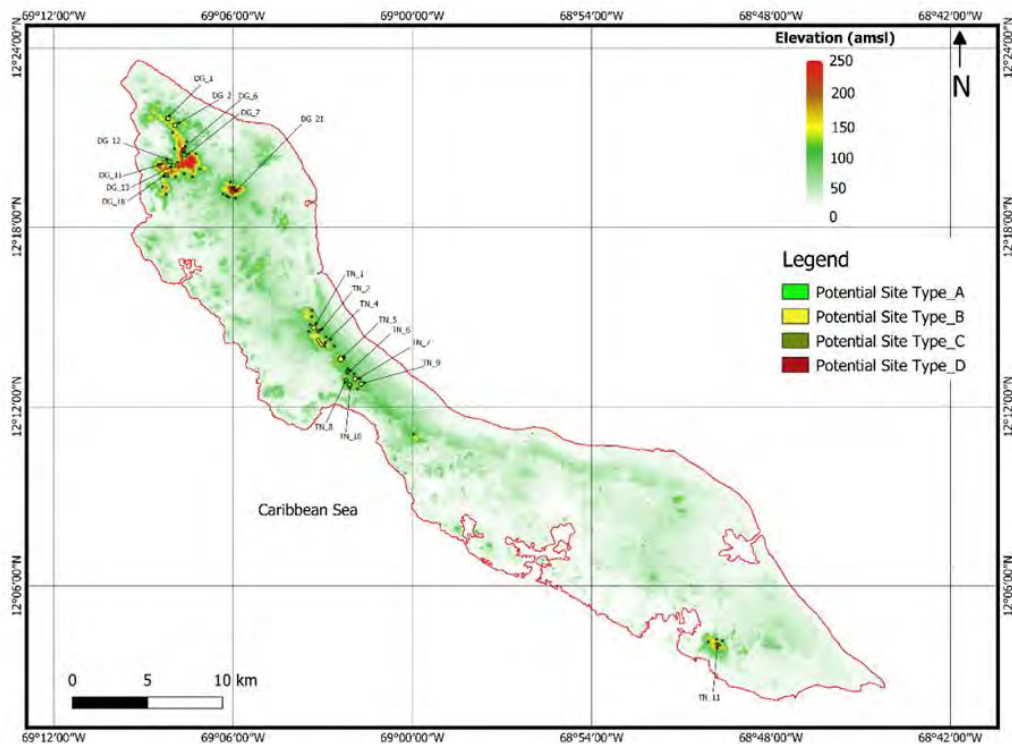

Figure: Potential dry gully and turkey nest sites for the upper reservoir on Curacao



Supplementary information - Underground Pumped Hydroelectric Storage

Reference

1. Underground Pumped Hydroelectric Storage, R.D. Allen, T.J. Doherty, L.D. Kannberg, Prepared for the U.S. Department of Energy under Contract DE-AC06-76RLO 1830, July 1984
2. Isaaksson G., D. Nilsson, T. Sjostrand, "Pumped storage power plants with underground lower reservoirs. Seventh World Power Conference, Section 2, Paper 160, Moscow, 1968.
3. Sorensen K.E., "Underground reservoirs: pumped storage of the future?" Civil Engineering, vol. 39, no. 66, 1969.
4. Tam S.W., Blomquist C.A. and Kartsounes G.T, "Underground pumped hydro storage - An overview", First Annual Conference on Mechanical and Magnetic Energy Storage Contractors' Information-Exchange, Luray, Virginia, October 24-26, 1978.
5. Beck H.P., Schmidt M., "Windenergiespeicherung durch Nachnutzung stillgelegter Bergwerke", Energie-Forschungszentrum Niedersachsen, Goslar, 31.08.11.
6. Uddin N., "Preliminary design of an underground reservoir for pumped storage", Geotechnical and Geological Engineering 21: 331–355, 2003.
7. Wong I. H. "An Underground Pumped Storage Scheme in the Bukit Timah Granite of Singapore", Tunnelling and Underground Space Technology, Vol. 11, No. 4, pp. 485--489, 1996.
8. Podvysotski A.A., Borodulin A.A., "Pumped-storage power plant with underground reservoir. Structural design. Prospects". Proceedings of the Vingt-cinquième Congrès des Grands Barrages, Commission Internationale des Grands Barrages, Stavanger (N), Juin 2015.

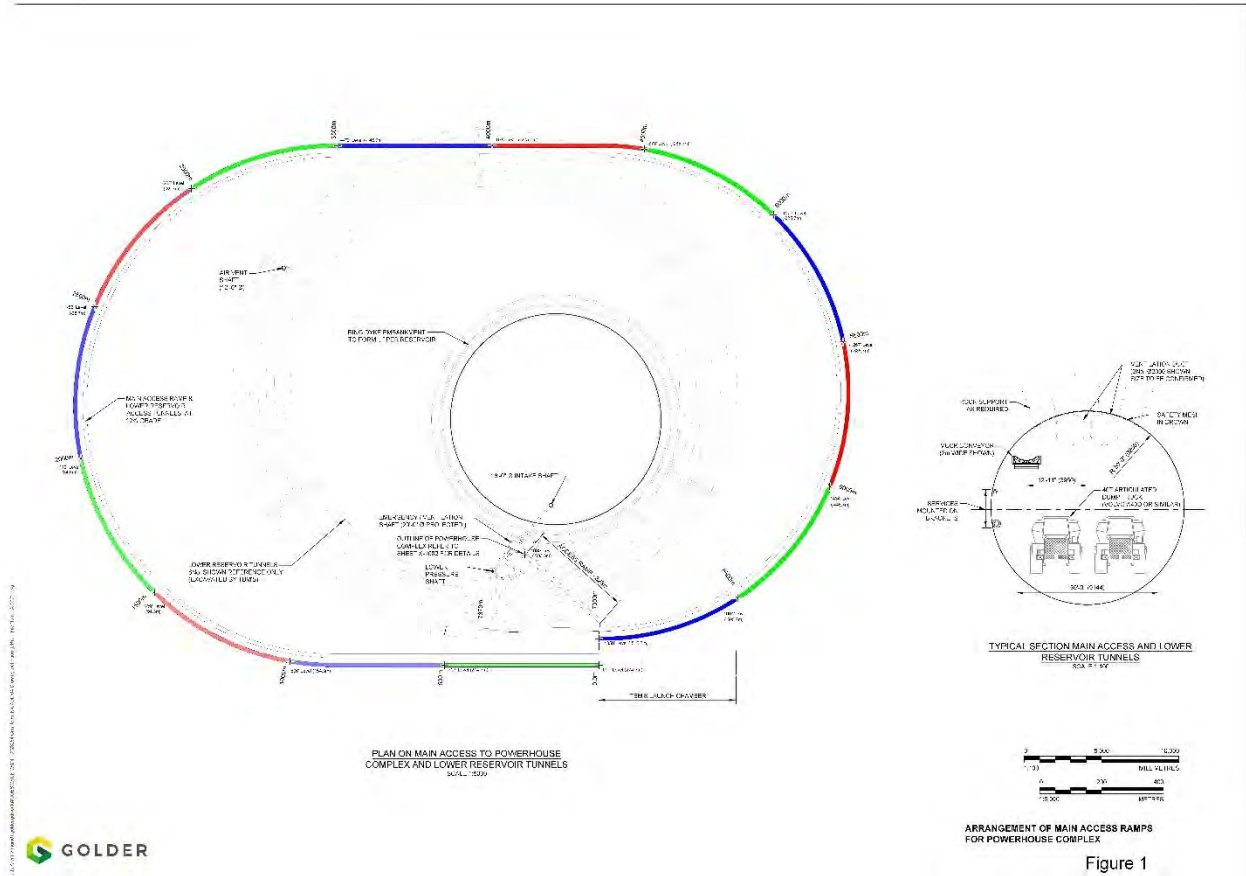
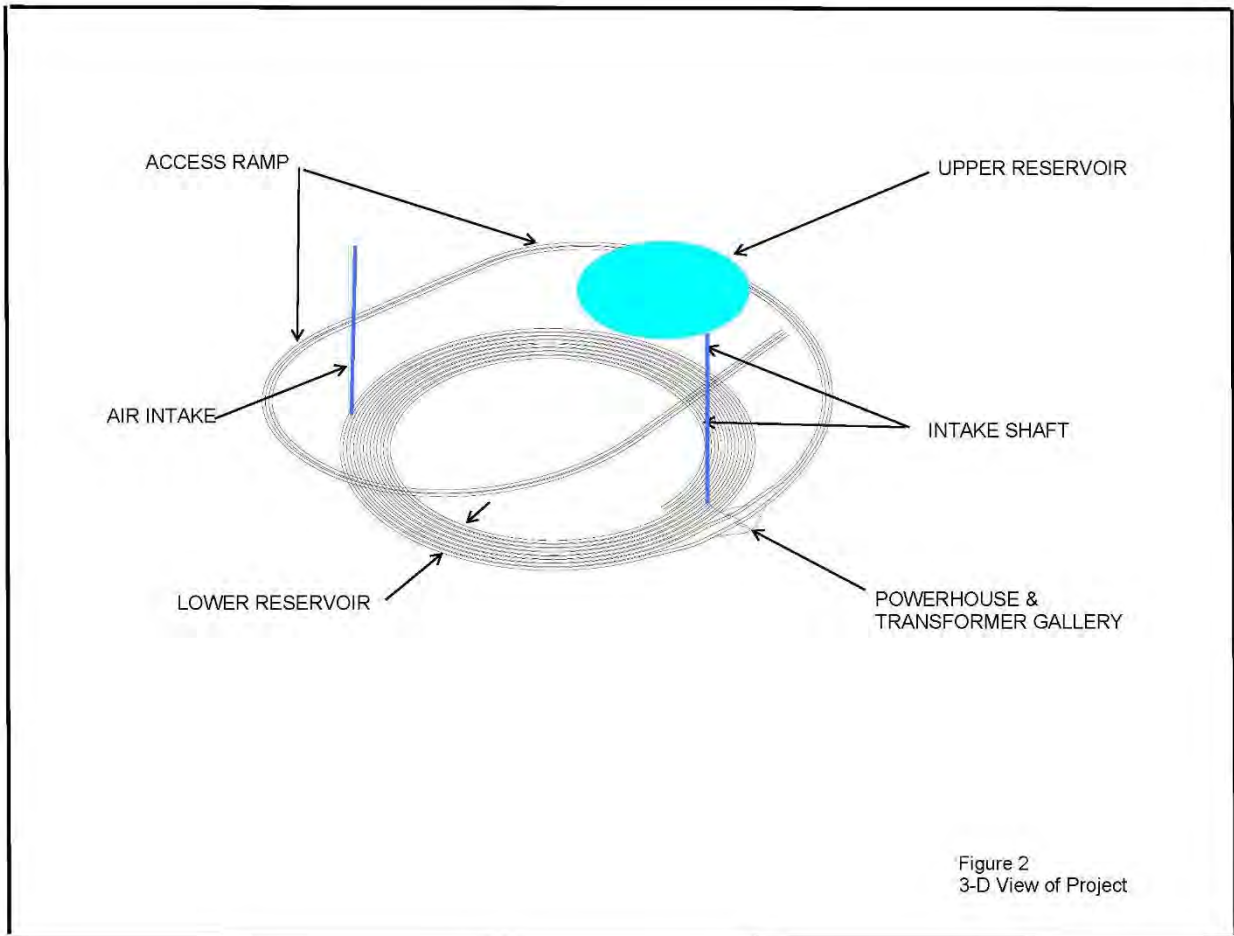

Figure 1



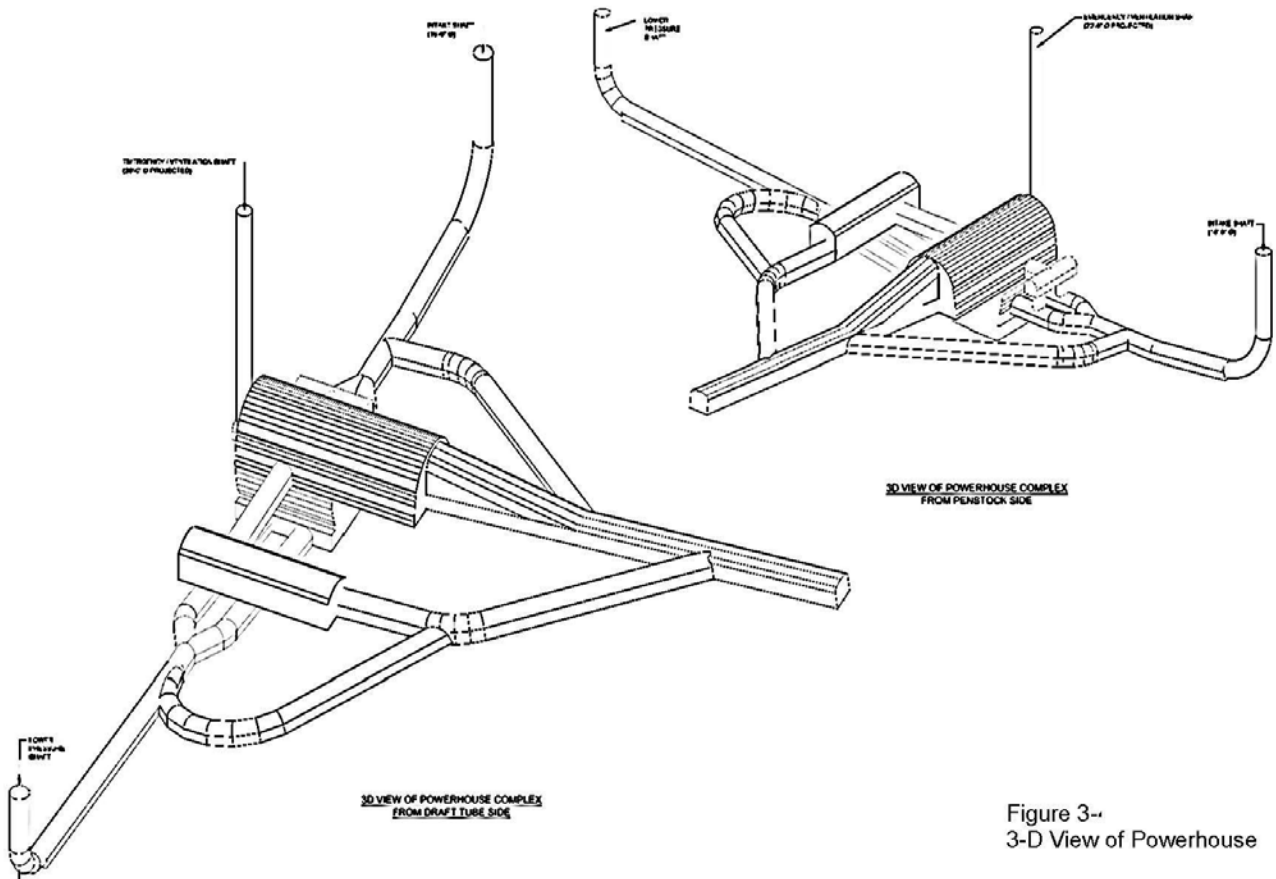
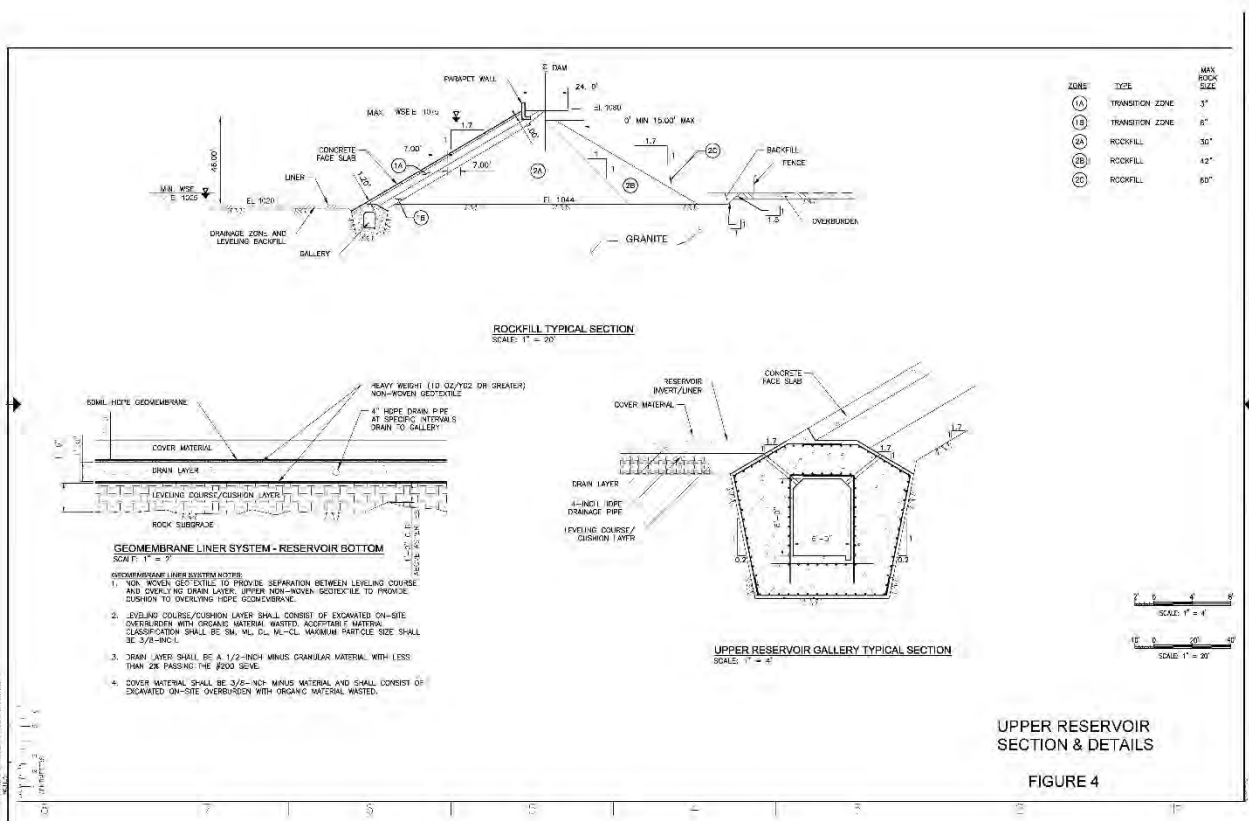

Figure 3-
3-D View of Powerhouse



UPPER RESERVOIR
SECTION & DETAILS

FIGURE 4

COST ESTIMATE
Granite Falls Pumped Storage Project Prefeasibility Report



Estimated Costs Feature	2019-Estimated Cost		
Direct Construction Costs			
Mobilization		20,000,000	
Upper Reservoir		78,722,530	
Powerhouse		241,983,690	
Underground Excavation		469,955,336	
Interconnection		29,116,504	
Make-up Water System		5,000,000	
Subtotal Direct Construction Costs		844,778,060.28*	
Construction Indirect Costs-20%		168,955,612	
Total Construction Cost		1,013,733,672	
Construction Management-5%		50,686,684	
Design Engineering-4%		54,979,000	
Contingency 25% on non excavation items**		135,944,584	
Total Direct Cost	\$	1,255,343,940.04	1,885 \$/Kw
Other Costs			
Feasibility Study		2,000,000	
Licensing Permitting		2,000,000	
Owners Cost-Sales Tax , Insurance , Financing-3.2%*		40,171,006	
Interest During Construction -7.25% 86 months		458,982,423	
Total Other Costs		503,153,428.86	
TOTAL PROJECT COST	\$	1,758,497,368.90	2,640 \$/Kw

* 25 % contingency on non-excavation items, -25% contingency is included in excavation cost.



REFERENCES

- [1] Underground Pumped Hydroelectric Storage, R.D. Allen, T.J. Doherty, L.D. Kannberg, Prepared for the U.S. Department of Energy under Contract DE-AC06-76RLO 1830, July 1984
- [2] Isaaksson G., D. Nilsson, T. Sjostrand, "Pumped storage power plants with underground lower reservoirs. Seventh World Power Conference, Section 2, Paper 160, Moscow, 1968.
- [3] Sorensen K.E., "Underground reservoirs: pumped storage of the future?" Civil Engineering, vol. 39, no. 3, 66, 1969.
- [4] Tam S.W., Blomquist C.A. and Kartsounes G.T, "Underground pumped hydro storage - An overview", First Annual Conference on Mechanical and Magnetic Energy Storage Contractors' Information-Exchange, Luray, Virginia, October 24-26, 1978.
- [5] Beck H.P., Schmidt M., "Windenergiespeicherung durch Nachnutzung stillgelegter Bergwerke", Energie-Forschungszentrum Niedersachsen, Goslar, 31.08.11.
- [6] Uddin N., "Preliminary design of an underground reservoir for pumped storage", Geotechnical and Geological Engineering 21: 331–355, 2003.
- [7] Wong I. H. "An Underground Pumped Storage Scheme in the Bukit Timah Granite of Singapore", Tunnelling and Underground Space Technology, Vol. 11, No. 4, pp. 485--489, 1996.
- [8] Podvysotski A.A., Borodulin A.A., "Pumped-storage power plant with underground reservoir. Structural design. Prospects". Proceedings of the Vingt-cinquième Congrès des Grands Barrages, Commission Internationale des Grands Barrages, Stavanger (N), Juin 2015.
- (9) Underground Pumped Hydroelectric Storage, R.D. Allen, T. J. Doherty, L. D. Kannberg, Battelle, July 1984 Prepared for the U.S. Department of Energy under Contract DE-AC06-76RLO 1830
- (10) <https://www.waterpowermagazine.com/features/featureinvestigating-aquabank/>
- (11) <https://drive.google.com/file/d/1UX95vc5To8r5UYIPEpFB52PWzPSKyh7q/view?usp=sharing>



Supplementary information - Retrofitting PSH on open pit mine

Table 2 Basic Assessment Criteria for Open Mine Pit PSH Opportunities

Characteristic	Preferred Situation	Rationale	Commentary
Length to Head Ratios	Smaller the better; Length to Head <10 preferred; Gross Head , larger the better. Typically in the range of 200m to 600m	Total waterway length from upper to lower reservoir intake, divided by gross head (average upper reservoir water elevation less average lower reservoir water elevation). Minimizes costs and project footprint	
Topography	Varied topography	Allows for reservoir construction with minimal excavation or embankments	Where the mine site only has a single open pit available for use (typically as the lower reservoir), the topography needs to lend itself to the construction of the second (upper) reservoir either in the form of an adjacent valley or elevated plateau for a fully banded storage.
Geology	Sound, unfractured, consistent, limited faulting	Limits reservoir leakage and foundation preparation requirements; provides suitable local construction materials	A common perception is that the existence of the mine operations means that the site geology will be well defined and minimal investment in site investigations will be required. Whilst this is true for the mine pit area, this may not apply to the proposed powerhouse and upper reservoir locations (assuming the pit forms the lower reservoir). Nevertheless, the scope of geotechnical site investigations are typically reduced compared to a greenfield site.
Power capacity	Maximum megawatts	Increases revenue potential. Pump loads are greater than generation.	Maximisation of the site potential will provide the lowest cost per MW installed; however, need to balance the power capacity (MW) with energy storage (MWh), the market demand profile and the services to be provided by the PSH facility.
Energy storage potential	MWh, Increases revenue potential and operational flexibility. Typical minimum hours of storage is 4 hours, average is 6 to 8 hours, but can be 24 hours or larger.	Product of plant capacity in MW and the hours of available storage (MWh); or potential energy associated with the upper body of water in relation to the lower storage space.	The usable volume (live storage) of the open mine pit will typically define the energy storage potential.



Characteristic	Preferred Situation	Rationale	Commentary
Construction	Powerhouse can be in a shaft or in a cavern. Water transfer pipe can be a tunnel or surface buried line.	Shaft powerhouse may be suitable up to 150MW. Larger units require a cavern.	Conventional surface powerhouses are unlikely to satisfy the submergence requirements for pumping mode. The Baixo Sabor Pumped Storage Project in Portugal, completed in 2016, has two 76.5MW reversible Francis pump-turbine units installed in separate shafts, 11.5m internal diameter and 79m high. The two 131MW reversible Francis pump-turbines at Portugal's Foz Tua Hydroelectric Development, completed in 2017, are housed in 68m deep shafts.
Water availability	Plentiful, available, and nearby. First fill important, and annual top up for evaporation	Reduces costs and risk exposure for first filling and replenishment water	Open pit mine PSH projects are generally closed loop – no natural water courses feeding either the upper or lower reservoirs. Accordingly, the source of water for first filling is an important consideration and should not be underestimated as it may influence the design of the project. Losses from a closed loop system should be minimal, but groundwater conditions and evaporation need to be taken into consideration. In hot climates the annual evaporation may exceed the annual rainfall resulting in a deficit. In such cases, provision for a suitable source of water to replenish the PSH system needs to be included in the project O&M considerations.



Characteristic	Preferred Situation	Rationale	Commentary
Environmental, regulatory, and land use	Closed loop, limited environmental exposure, desirable land ownership	Reduces costs, risk exposure, permitting requirements, and development duration	Repurposing disused or abandoned mines for PSH presents an attractive proposition to authorities. For example, Queensland currently has over 11,000 abandoned / closed mines of various scale; the maintenance of these sites and their environmental footprint poses a significant financial drain on the State Government. The successful development of PSH schemes at these sites would alleviate environmental costs and liability to the State. For mine operators, repurposing their asset at the end of its mine life provides an opportunity to offset rehabilitation costs and create an ongoing beneficial asset. Development of a PSH scheme could become a central feature of future mine closure plans.
Electrical Power Transmission	Nearby and available transmission capacity. Higher the kV class of line the better.	Reduces potential costs of new T-lines and/or grid upgrades	Even if the mine operations are served by an existing transmission connection, depending on the size of the PSH project, it is likely that an upgraded connection to the nearest substation/grid infrastructure will be required.
Power marketing	Large spreads, suitable partnership opportunities, multiple offtakers	Increases revenue potential and ease of marketing; reduces risk exposure	Right sizing the PSH project to the market is an important consideration.



Supplementary information - PSH utilising underground mine

Pyhäsalmi mine (Finland)

PROJECT FACT SHEET

Technical Data	
Plant capacity	75 MW (+75 MW)
Number of Units	1 (split pump and turbine)
Flexible operation range	±75 MW
Operation time turbine / pump	7/9 h
Reservoir volume	162.000 m ³
Cycle efficiency	77 %
Head	1400 m
Construction time: 38 month	
Total Capex: €100M (price basis 2016)	
Expected IRR: information on request	



COPYRIGHT©POYRY

POYRY PRESENTATION 19
OCTOBER 2016

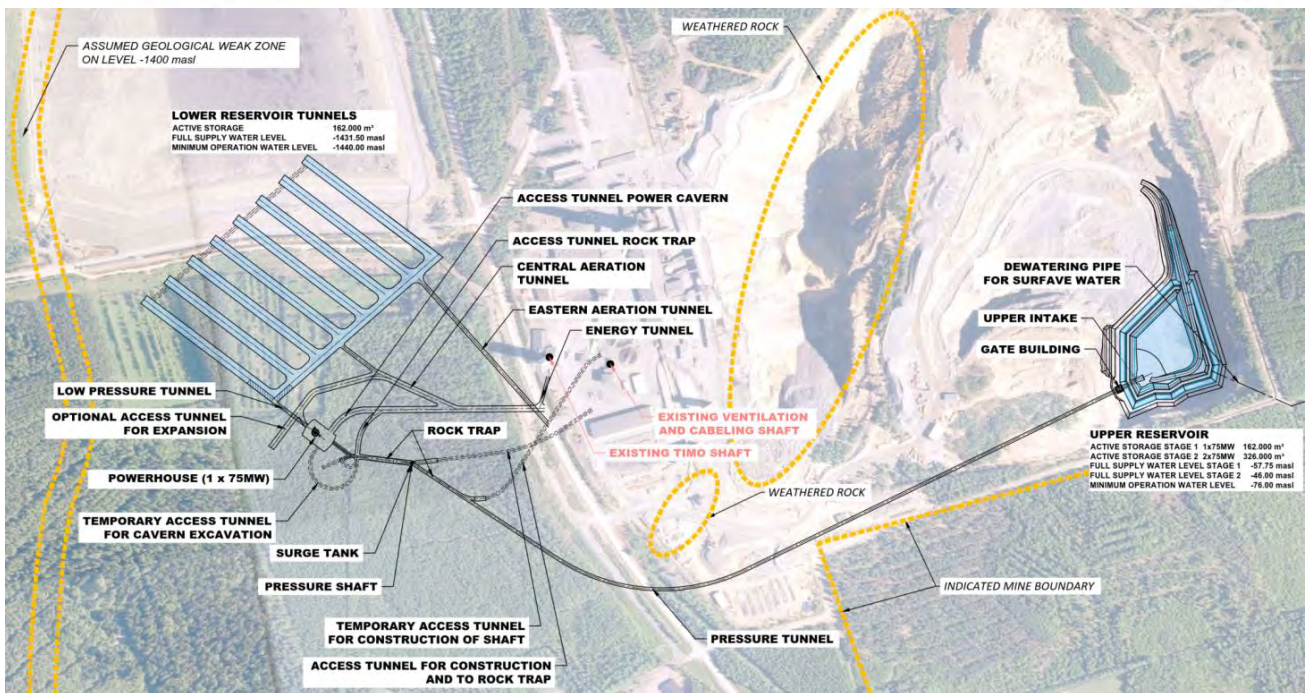

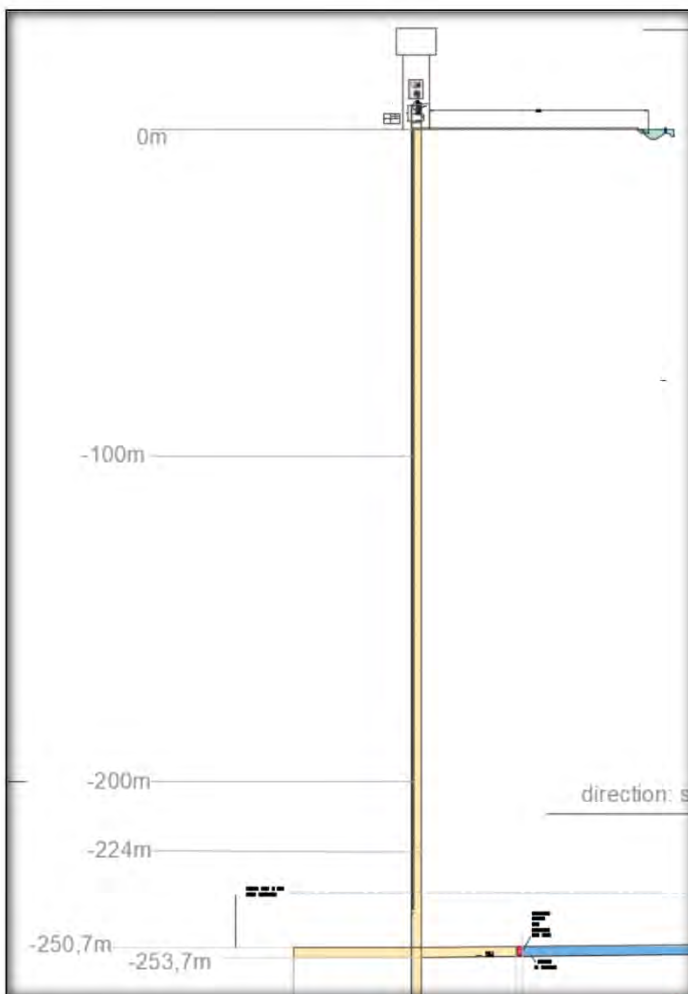



Supplementary information - Pumped Storage operating range extension – The Alqueva

Main use case under development:

- Alqueva powerplant (Portugal, EDP), under investigation in XFLEX-Hydro R&D project.
www.xflexhydro.net

Other references:

- Salomonde (PSP, EDP, Portugal), range extension based on site test & model test
- Alqueva (PSP, EDP, Portugal), range extension based on site test & model test
- Valeira (Run-of-river, EDP, Portugal), range extension based on site test and condition monitoring

Related publications :

- "Range Extension – Methodologies to increase operational flexibility of hydropower plants", F.André, M.Roque, V.Bouillet, T.Marques, P.Y.Lowys, F.Duarte, H.Mollet, P.Almeida, Hydro 2019.
- "How a combination of hydro expertise, condition monitoring, and digital technology provides more flexible Hydro turbines", P.Pépin, P.Y.Lowys, V.Bouillet, F.André, Hydro 2017
- "Increasing the Operating Range of Francis Turbines by Considering Dynamic Phenomena at Partial Load", J.Brammer, F.Duparchy, P-Y.Lowys, M.Thibaud, K.Wheeler, T.De-Colombel, Hydro 2016



Supplementary information - Obermeyer Pump Turbine: Cost Effective Pumped Storage Hydropower

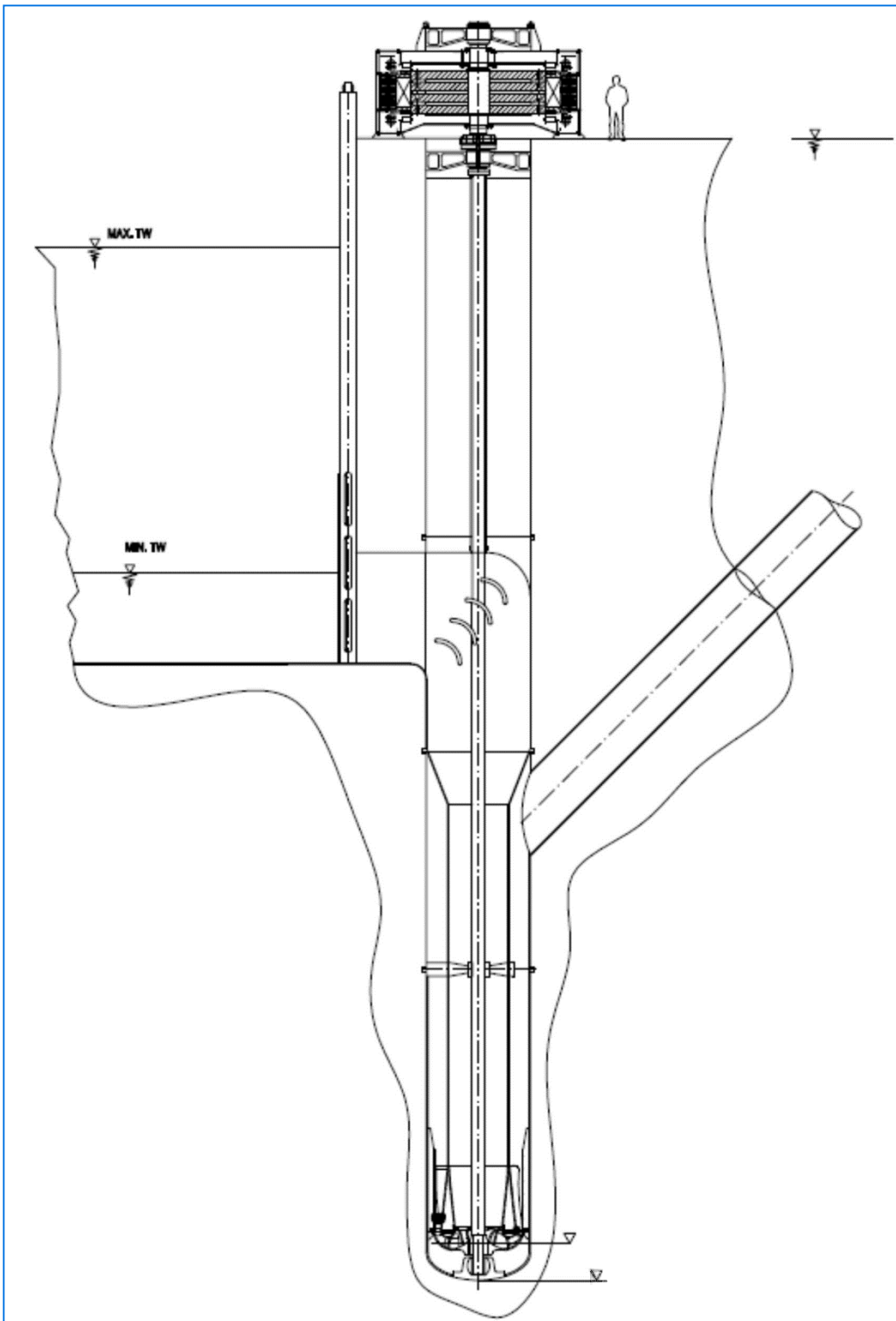

Figure – Obermeyer pump turbine with generator above the runner

Example Project for Comparison - based on 2011 EPRI report "Quantifying the Value of Hydropower in the Electric Grid - Plant Cost Elements".

Site



	Conventional	Obermeyer
Capacity (MW)	160	183
Number of Units	2	2
Roundtrip efficiency	70%	80%
Head (ft)	1500	1500
Flow (cfs)	1800	1800
Tunnel Length (mile)	1	1
Tunnel Diameter (ft)	18	18
Vertical Shaft Length (ft)	1800	3600
Vertical Shaft Diameter (ft)	12	9
Access Tunnel Length	1	0
Hours of generation	8	8
Upper Reservoir		
Capacity (ac-ft)	1428	1428
Height	50	50
Length	750	750
Dam Volume (cy)	1145833	1145833
Lower Reservoir		
Capacity	1428	1428
Height	50	50
Length	750	750
Dam Volume (cy)	1145833	1145833
Voltage	230	230
Transmission Distance (mile)	10	10

Site Cost				
	Conventional		Obermeyer	
	160 MW		183 MW	
	Total Cost	per kW	Total cost	per kW
Civil works	\$ 53,729,167	\$ 335.81	\$ 53,729,167	\$ 294
Underground work	\$ 122,177,898	\$ 764	\$ 60,624,000	\$ 331
Electro-Mechanical	\$ 70,400,000	\$ 440	\$ 80,520,000	\$ 440
Transmission	\$ 5,660,800	\$ 35	\$ 5,660,800	\$ 31
Indirect	\$ 75,590,359	\$ 472	\$ 50,133,492	\$ 274
Contingency	\$ 75,209,756	\$ 470	\$ 56,195,892	\$ 307
Savings		\$ -	\$ 95,904,631	\$ 840
Total	\$402,767,981	\$ 2,517	\$ 306,863,350	\$ 1,677



Supplementary information - Hybrid Pumped Storage Hydropower-Battery Storage

Reference Projects

Hybrid Battery Pumped Storage Project:

- Kraftwerksgruppe Pfreimd, Germany: 12.5 MW/13 MWh Siemens Siestorage project at the pumped storage hydro power station owned by Engie Deutschland.⁶⁷
- Kauai Island, Hawaii: A solar-battery-pumped storage hybrid plant is currently being developed by AES to provide the island with long-duration carbon free energy combining the capabilities of solar generation, short-duration energy storage, and long-duration pumped storage hydropower.⁶⁸

Conventional Hydropower Projects:

- Ifugao and Isabela, Philippines: 20 MW battery energy storage system deployed at the Magat Hydro Electric Power Plant - a conventional hydropower plant to support the local grid during low water level summer periods.⁶⁹

Run-of-River Hydropower Projects:

- Alfafal I, Chile: 10 MW/50 MWh energy storage co-located at run-of-river hydropower to provide energy arbitrage and firm peaking capacity. Due to recent regulatory changes, the hybrid asset is able to capture revenue from the full 10 MW storage asset in the Chilean capacity market.⁷⁰
- American Electric Power (AEP), USA: Operating a 4 MW battery energy storage (1 hr storage) integrated with Buck (8.5 MW) and Byllesby (21.6 MW) hydropower plants. This integrated operation enhances the frequency regulation service and hence increase the revenue within the Pennsylvania-New Jersey-Maryland (PJM) electricity market.⁷¹
- Kodiak Electric Association, Kodiak, Alaska, USA: The microgrid in Kodiak, is operating a 3 MW battery energy storage. This is integrated with Kodiak's 33 MW hydropower capacity to enhance grid reliability, reduce wind generation curtailment, and diesel fuel consumption.⁷²
- Cordova Electric Cooperative, Cordova, Alaska, USA: The microgrid in Cordova, is operating a 1 MW / 1 MWh Li-Ion battery energy storage system to reduce diesel fuel consumption and serve as a spinning reserve. This reserve is needed for reliable operation addressing highly dynamic fishing loads in the area while it can also reduce curtailment from the 7.5 MW hydropower generation.⁷³

⁶⁷ "Siemens to supply 12MW battery storage unit for Engie's hydropower plant in Germany", 17 March 2017, NS Energy. Available [Online]: <https://www.nsenergybusiness.com/news/newssiemens-engie-to-12mw-develop-pumped-storage-hydro-in-germany-170317-5765578/>

⁶⁸ Julian Spector, "Kauai to Hit 80% Renewable Power With Solar-Charged Hydro Storage", 8 January, 2021, Greentechmedia. Available [Online]: <https://www.greentechmedia.com/articles/read/kauai-to-hit-80-renewable-power-with-solar-charged-hydro-storage>

⁶⁹ "Battery energy power source eyed to boost power in North Luzon", 18 December 2018, Energy Central News. Available [Online]: <https://energycentral.com/news/battery-energy-power-source-eyed-boost-power-north-luzon>

⁷⁰ Pablo Barrague, et al. "Virtual dams: Harvesting the output of hydropower with dispatchability constraints". White Paper, Fluence, 2020.

⁷¹ "Integrating energy storage", 25 January, 2018, International Water Power & Dam Construction. Available [Online]: <https://www.waterpowermagazine.com/features/featureintegrating-energy-storage-6036809/>

⁷² Darron Scott, "Testimony in Support of H.R. 220". Written testimony before the Subcommittee on Water, Power and Oceans, House Committee of Natural Resources, April 4, 2017.

⁷³ "BESS Application in a Microgrid – Cordova Electric Cooperative". Electricity Advisory Committee, October 16, 2019, Arlington, Virginia, USA,



Supplementary information - Hybrid Renewable Modular Closed-Loop Scalable PSH System

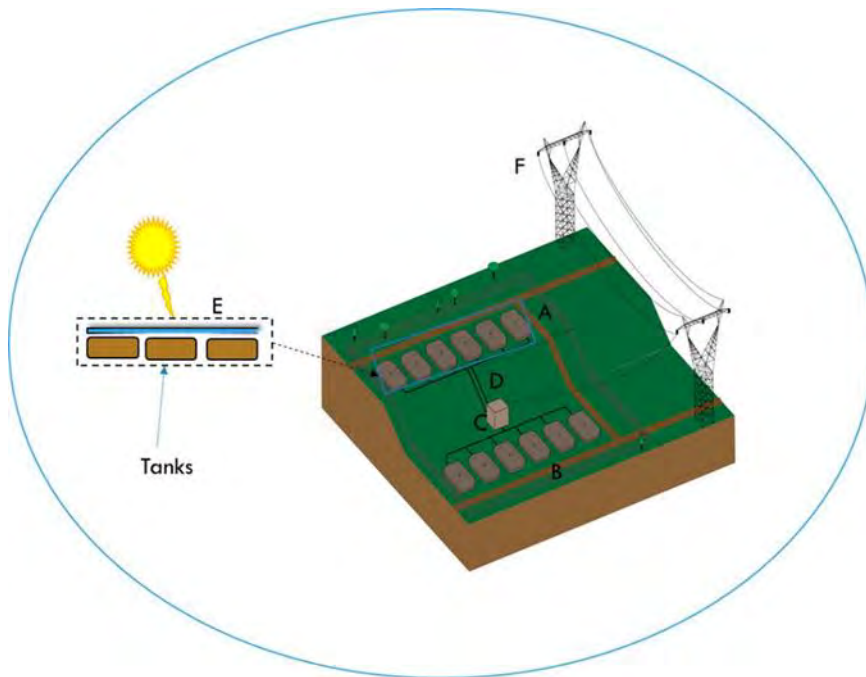

Figure 1: Schematic of the patent-pending hybrid modular closed-loop scalable pumped storage system with the component designations as follows: (A) Upper reservoir; (B) Lower reservoir; (C) Powerhouse (well pump); (D) Penstock; (E) Solar panels; (F) Transmission lines



Figure 2: (Left): Estimated capital costs for h-mcs-PSH systems per kW installed for 3, 5 and 10 MW systems, not including renewable component. (Right): Estimated installed system costs with and without solar panels, for system capacities ranging between 100 kW to 10 MW. The cost of the solar panels was based on generation occurring during periods of sunshine at the system capacity (MW).

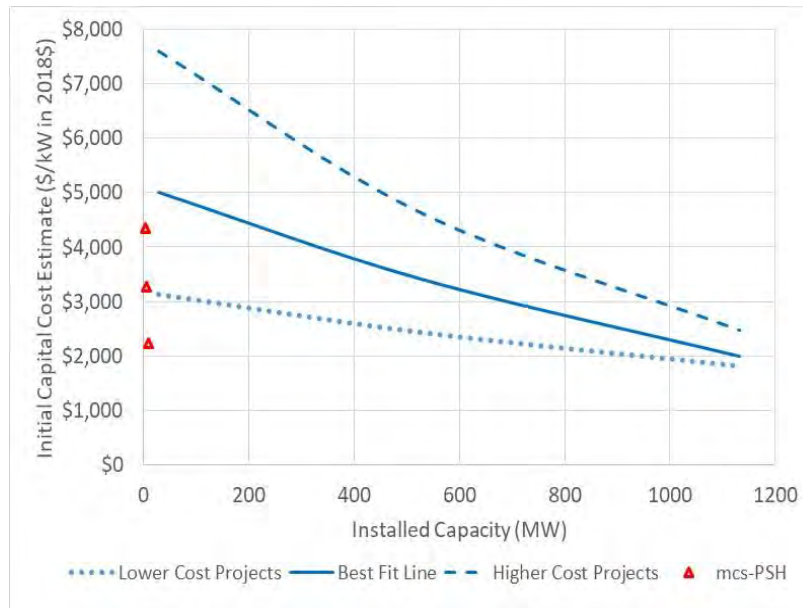

Figure 3: Comparison of initial capital cost estimate (\$/kW) of current technology versus traditional PSH projects. Dollar value is based on year 2018. Source: A. Witt, B. Hadjerioua, N. Bishop, and R. Uria, "Evaluation of the Feasibility and Viability of Modular Pumped Storage Hydro (m-PSH) in the United States" Oak Ridge National Laboratory, Oak Ridge, Tennessee, September 2015.

Table 1: Breakdown of cost percentages per category for three different capacities of the current technology. Note that some costs are not included such as solar components, power-grid connection and some civil works (e.g. accommodation of terrain for placing reservoirs).

Generation capacity	1 MW	3 MW	10 MW
Available Head	76.2 m	175.3 m	304.8 m
Computed RTE (round trip efficiency)	72.5%	74.3%	75.9%
Fractions of installed cost			
Reservoirs	46.3%	65.3%	69.3%
Pump-turbine	12.3%	8.2%	7.9%
Penstock & surge device	3.1%	2.3%	2.5%
Controls, valves, & sensors	3.4%	3.0%	2.6%
Ancillary works	18.8%	10.3%	7.7%
Installation	16.1%	10.9%	10.1%

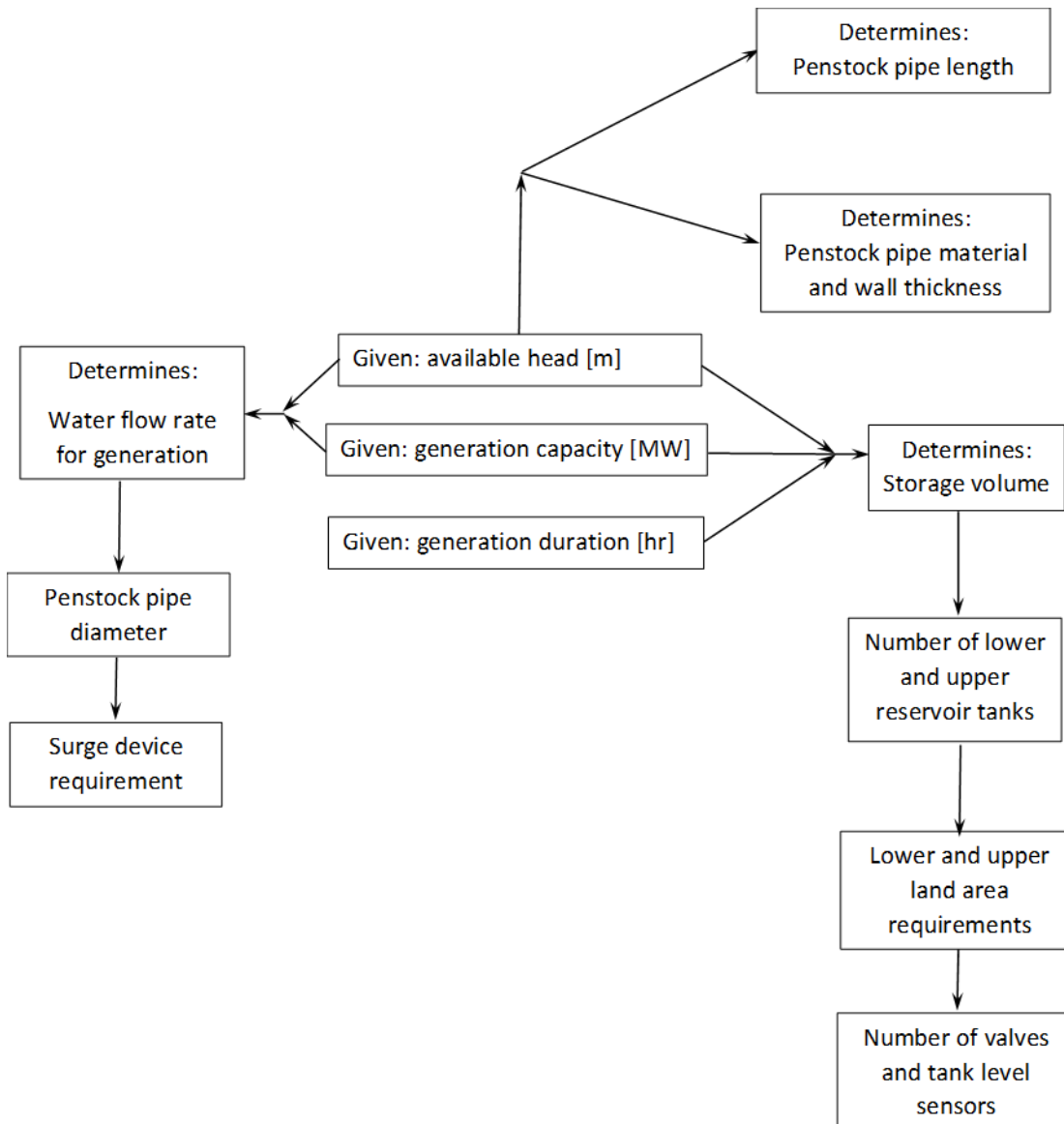

Figure 4: Flowchart of the process used in calculating various critical parameters for the h-mcs-PSH systems. Once the number or size of the main components are determined, costs of items are used to complete cost analysis.



Supplementary information - Integrated Pumped Hydro Reverse Osmosis Clean Energy System (IPHROCES)

References

1. Slocum, Alexander H., et al. "Integrated Pumped Hydro Reverse Osmosis Systems." *Sustainable Energy Technologies and Assessments*, vol. 18, Dec. 2016, pp. 80–99. ScienceDirect, DOI:10.1016/j.seta.2016.09.003.
2. Slocum et al. assessed integrated pumped hydro reverse osmosis systems as a "symbiotic match" between pumped hydropower and storage and desalination using reverse osmosis. The article explores the topographical restrictions for application of this integrated solution and concludes that there are many benefits to the co-location and integration of these existing technologies. This article furthers the need to explore opportunities to reduce the H/L ratio below 0.10 to expand the locales of opportunity.
3. US 2018/0290902 A1 – US Patent - Integrated system for generating, storing and dispensing clean energy and desalinating water. Applicant Oceanus Power and Water. The US patent application was published in October 2018 and approved in November 2020. It claims novelty of the integration of existing technologies, pumped hydropower and desalination, as well as solar and wind power generation plants to generate power for a co-located and integrated system. This patent explicitly states that the system consists of a hydraulic storage facility, desalination plant and a penstock that connects the storage facility and desalination plant. This patent could be expanded in the future to address advancements in reducing the H/L ratio and system efficiency. Furthermore, if hydrogen production becomes a reality, this patent would require an amendment to enable Oceanus to bring all three technologies together in a market application.



Supplementary information - Thermal Pumped-Storage Hydropower

References

1. Brunström C, Hillström CG (1987): The Lyckebo project, solar district heating with seasonal storage in a rock cavern.
2. Píkl FG et al. (2020): TRI-STO-GEN. Submission documents for the Helsinki Energy Challenge.
3. Píkl FG (2017): Pumped-Storage Hydropower combined with Thermal Energy Storage. Master's thesis. 260 p. Graz University of Technology. (in German)
4. Renforth P (2012): The potential of enhanced weathering in the UK.
5. Schuiling RD, Krijgsman P (2006): Enhanced Weathering: An effective and cheap tool to sequester CO₂.
6. Moosdorf N, Renforth P, Hartmann J (2014): Carbon Dioxide Efficiency of Terrestrial Enhanced Weathering.
7. Beerling et al. (2020): Potential for large-scale CO₂ removal via enhanced rock weathering with croplands.

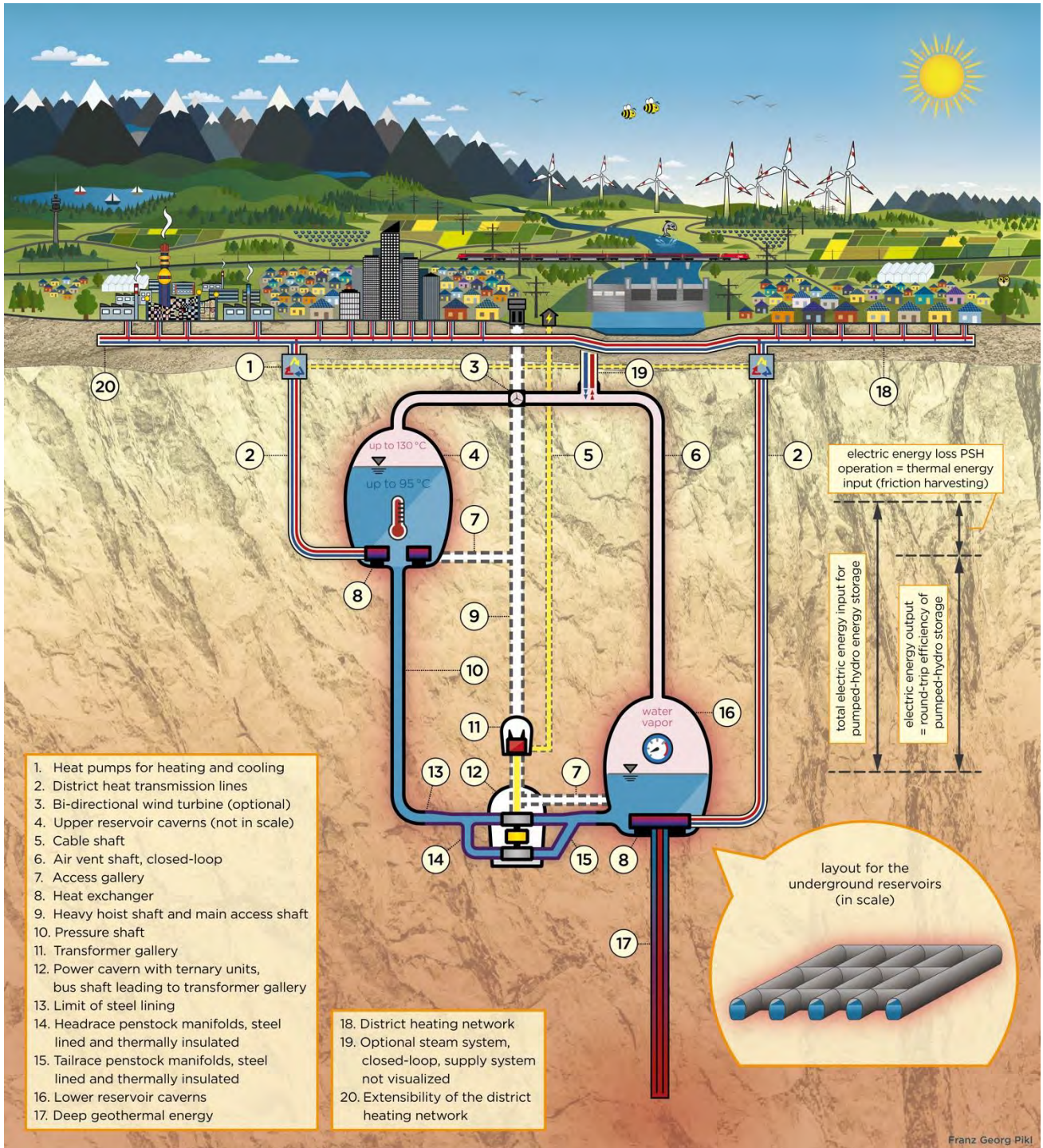

Figure 4: A Thermal Underground Pumped-Storage System for the holistic storage and supply of electricity, heat and cooling (ref. Franz Georg Pikel)



Cost breakdown of a TUPH

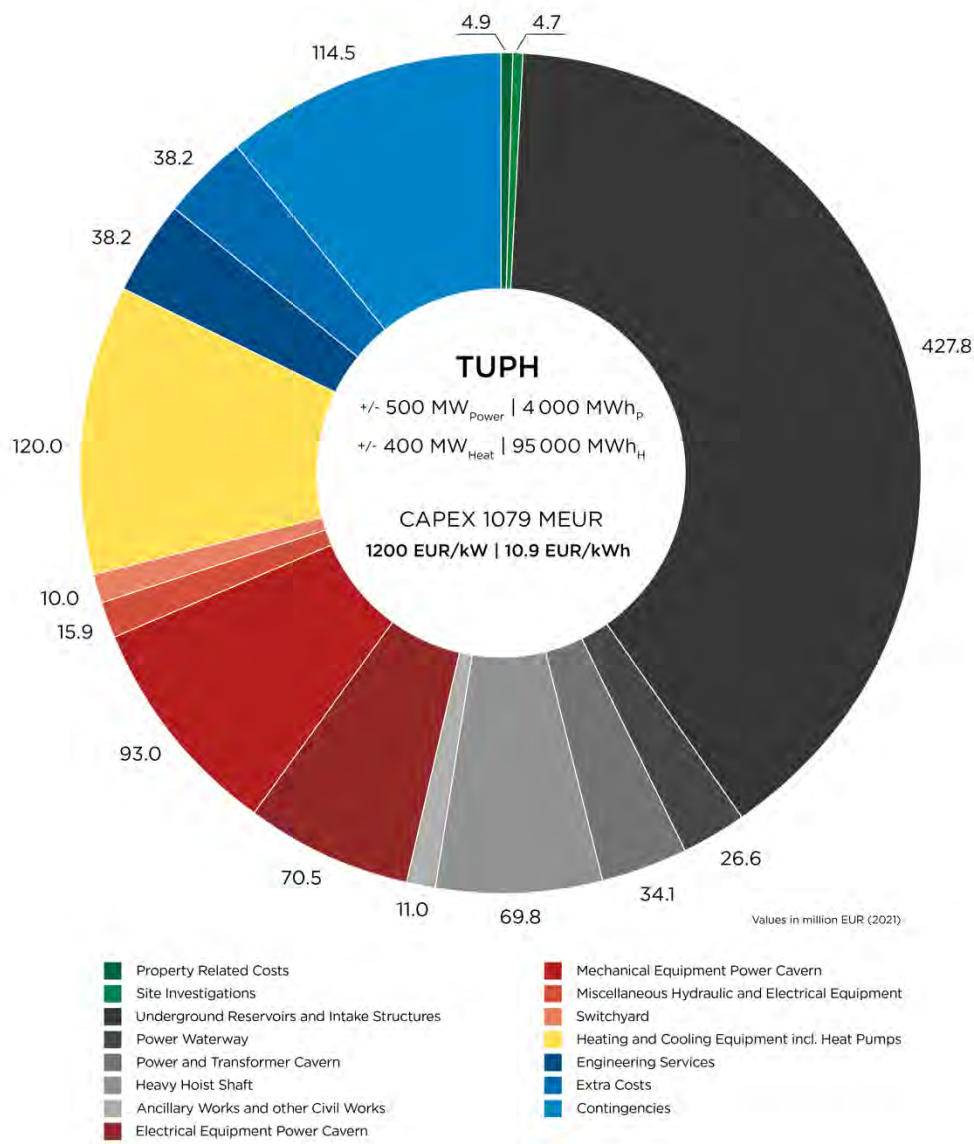

Figure 5: Cost breakdown, total CAPEX, power capacity cost (EUR/kW) and energy capacity cost (EUR/kWh) for a 500 MW_P and 400 MW_H TUPH case study [2]

Reference

- Pikel FG, Richter W, Zenz G (2017): Pumped-storage technology combined with thermal energy storage - Power station and pressure tunnel concept. *Geomechanics and Tunnelling* 10(5): p. 611–619.
- Pikel FG, Winner of the ICOLD Innovation Award (2018): Thermal Pumped-Storage Hydropower.
- Pikel FG, Richter W, Zenz G (2019): Large-scale, economic and efficient underground energy storage. *Geomechanics and Tunnelling* 12(3):2 p. 251–269.
- Pikel FG, Richter W, Zenz G (2020): Integrative and future-proof pumped-storage hydropower. Springer, *Zeitschrift für Energiewirtschaft* 44 p. 39–46. (in German)
- Boehler C (2019): Case Study for an Underground Pumped Hydro Storage for the city of Graz. Master's thesis. Graz University of Technology.
- Thek G (2021): Design concept for the power waterway of Thermal pumped-storage power plants. Master's thesis. Graz University of Technology. (in German)