

## PUSH SIDE MOUNTING

LEFT HAND DOOR SHOWN

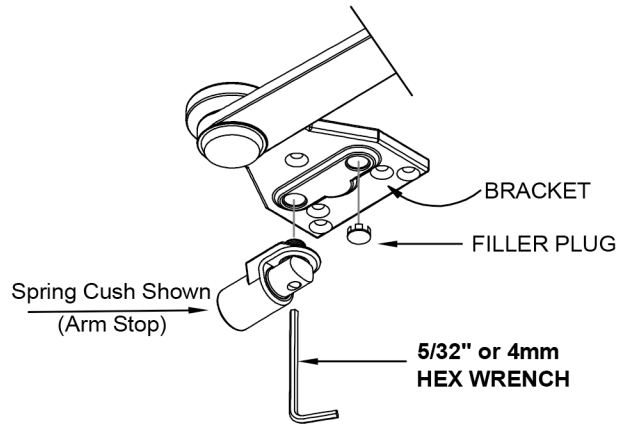
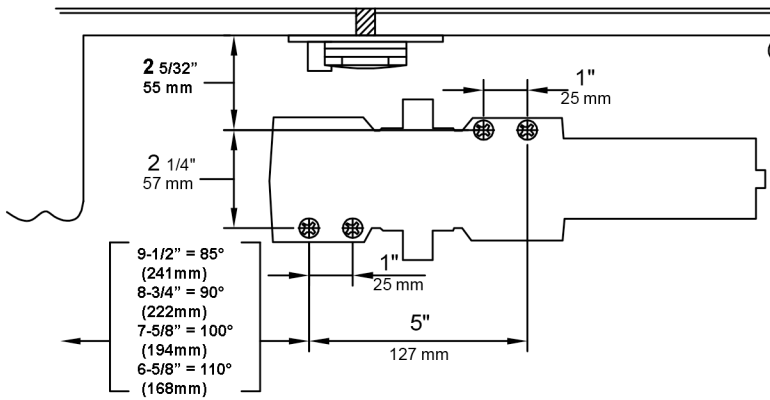
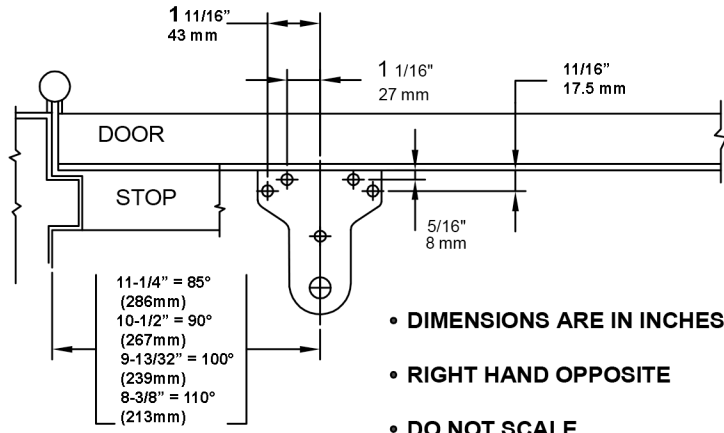

### DOOR CLOSER ADJUSTMENT

L: LATCH SPEED VALVE  
S: SWEEP SPEED VALVE  
B: BACKCHECK VALVE

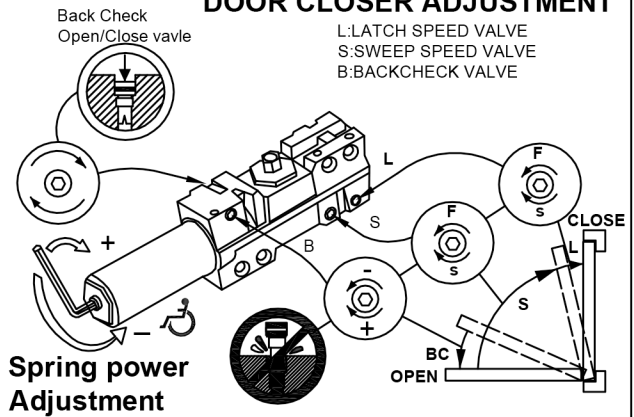

### Power Adjustment Chart

CLOSER SIZE	1	2	3	4	5	6
CLOCKWISE TURNS	-3	0	3	7	11	19

## PUSH SIDE MOUNTING

RIGHT HAND DOOR SHOWN

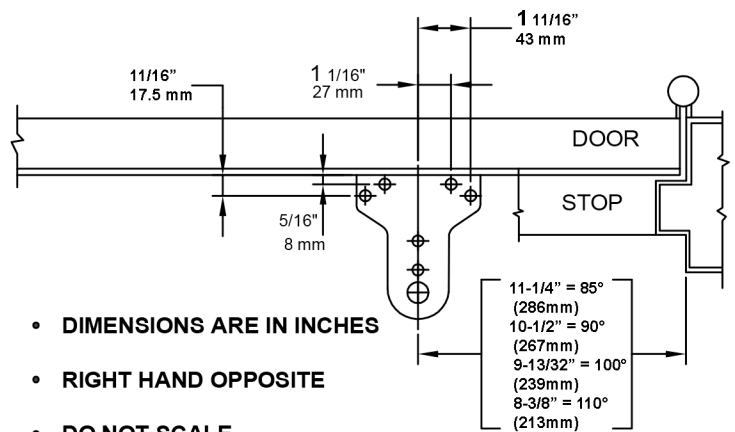
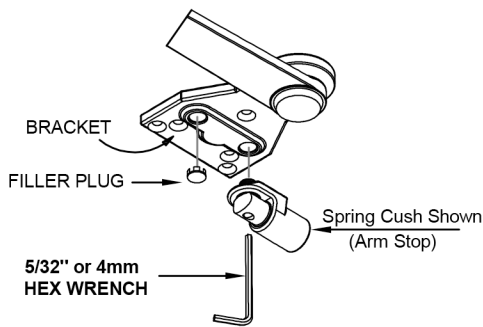

### DOOR CLOSER ADJUSTMENT

L: LATCH SPEED VALVE  
S: SWEEP SPEED VALVE  
B: BACKCHECK VALVE

Back Check Open/Close valve

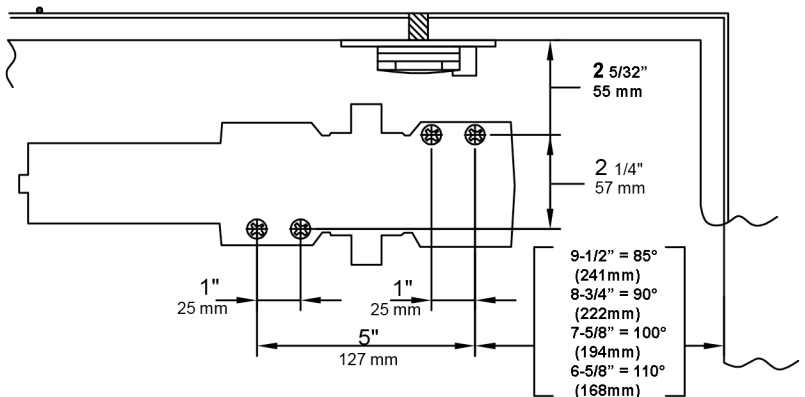
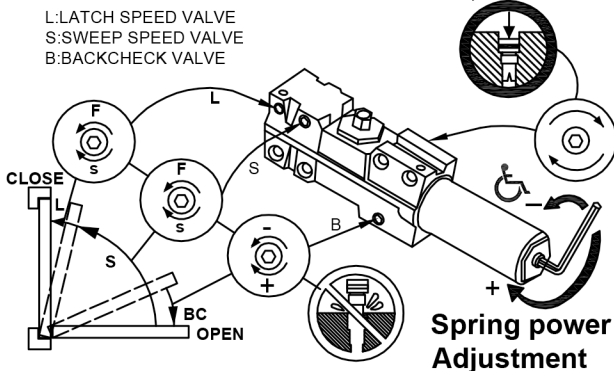

## How to fix the Arm Stop /Spring Cushion Stop

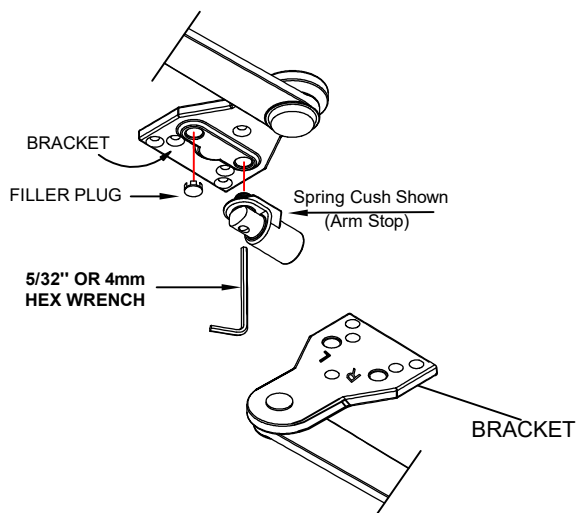

On back of BRACKET there are letters marked "R" and "L".  
 For Right Hand door install the Arm Stop /Spring Cushion Stop in the hole on the "R" side.  
 For Left Hand door install the Arm Stop /Spring Cushion Stop in the hole on the "L" side.  
 The Arm Stop /Spring Cushion Stop can be secured with the 5/32" (4mm) Hex wrench provided in the screw pack.

Arm Stop /Spring Cushion Stop /Filler Plug Accessories



# INSTALLATION SEQUENCE

LEFT HAND DOOR SHOWN- RIGHT HAND DOOR OPPOSITE



## CAUTION

IMPROPER INSTALLATION OR REGULATION  
 MAY RESULT IN PERSONAL INJURY OR  
 PROPERTY DAMAGE. FOLLOW ALL  
 INSTRUCTIONS CAREFULLY.

Illustration 1

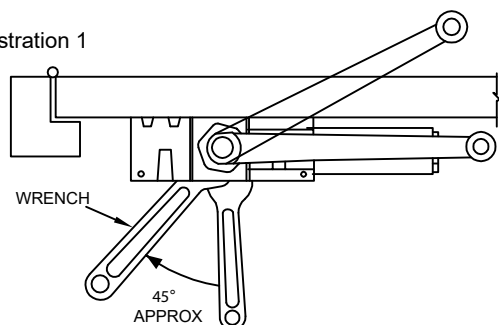

## INSTALLATION INSTRUCTIONS

1. Using template dimensions shown above. Mark FOUR (4) HOLES ON DOOR for door closer and FOUR (4) HOLES ON FRAME for parallel bracket.
2. Mount closer on door using screws provided. Latch and sweep adjust valves MUST BE POSITIONED TOWARDS THE HINGE EDGE.
3. Use a wrench or extra arm to turn the bottom end shaft ~45° and put the main arm on the upper end shaft. Make sure the main arm is parallel with the door- See Illustration 1.

## IMPORTANT REMARKS

DO NOT allow door to slam into frame.

A normal standard closing time from 90° open position is 5 to 7 seconds evenly divided between main closing (Sweep) speed and latching speed. Adjust the SWEEP speed first, then adjust the LATCHING speed.

For slower closing speed of door, turn adjusting valve "S" clockwise and counter clockwise for faster speed.

Latching speed is controlled in the same manner as Sweep speed adjustment.

## ADJUSTABLE BACKCHECK FUNCTION

This function is essential to proper operation of CUSH Type arm. Use enough to prevent arm from striking stop with impact. See page 1.

## ATTACH COVER (if provided)

Install cover using screws provided.

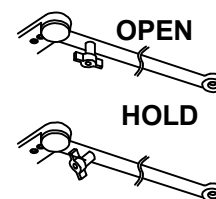

## HOW TO HOLD OPERATION (if applicable)

A quarter turn on the HOLD-OPEN CONTROL HANDLE engages or disengages hold-open.

