

PUSH SIDE MOUNTING
LEFT HAND DOOR SHOWN

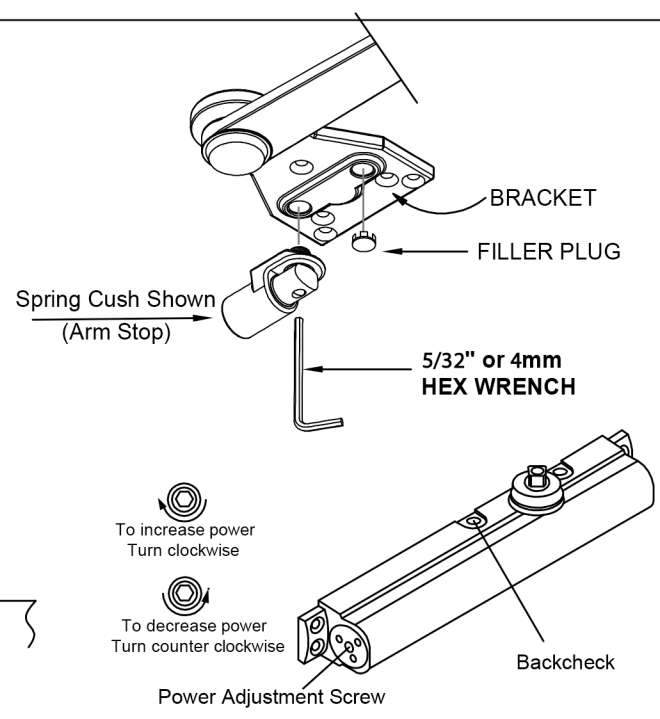

MODEL NO.	OPENING	DIMENSION
		A
TDC 85-CUSH TDC 85-HCUSH TDC 85-SCUSH TDC 85-SHCUSH	To 90°	3 1/2" (89 mm)
	To 100°	1 1/4" (32 mm)

PUSH SIDE MOUNTING
RIGHT HAND DOOR SHOWN

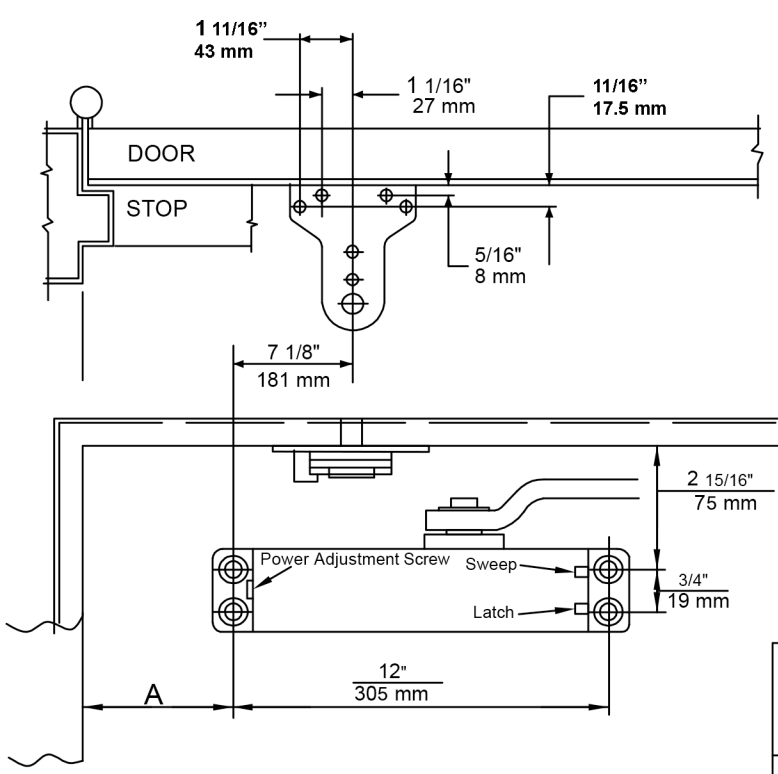
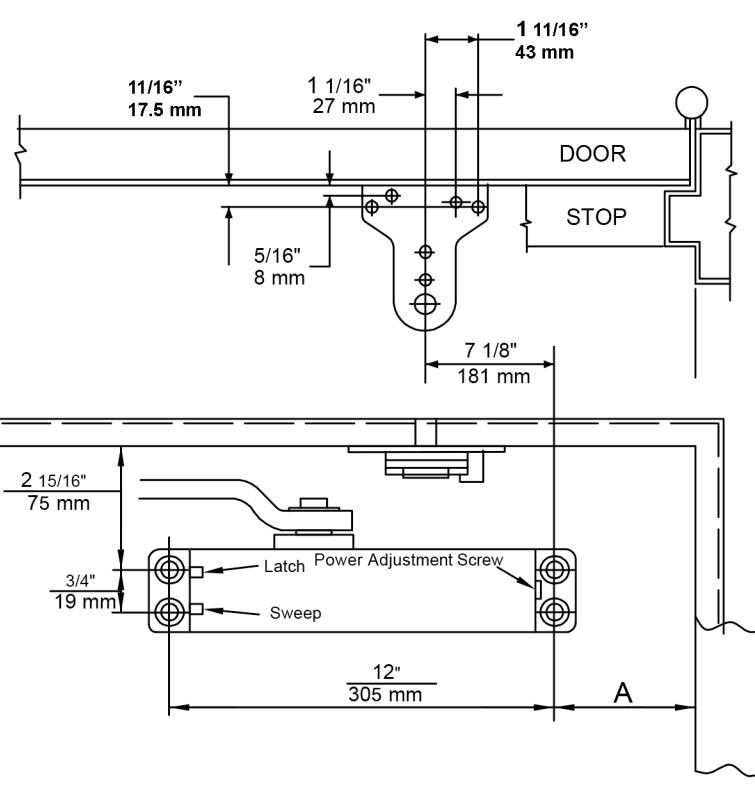
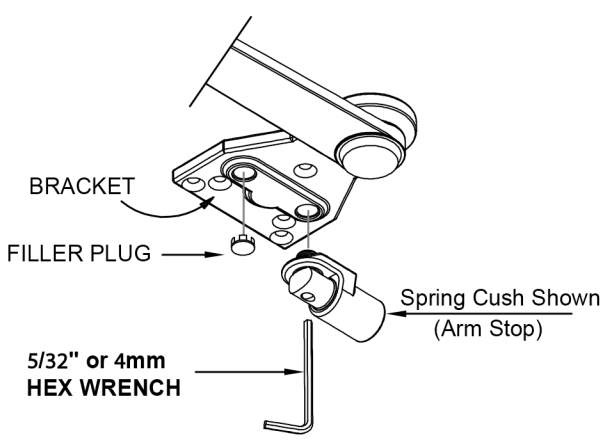

DOOR CLOSER ADJUSTMENT

- L: LATCH SPEED VALVE
- S: SWEEP SPEED VALVE
- D: DELAY SPEED VALVE
- B: BACKCHECK VALVE

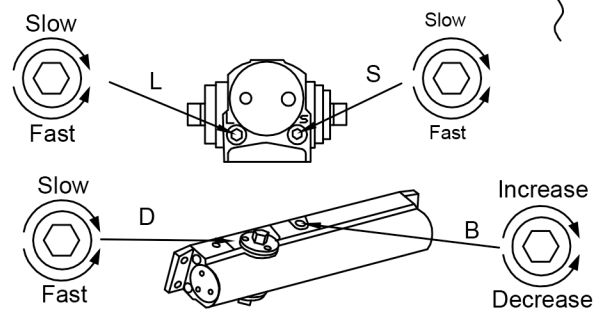

How to fix the Arm Stop /Spring Cushion Stop

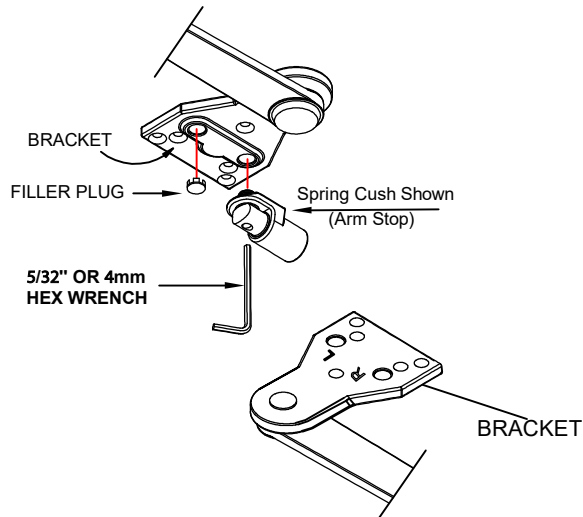

On back of BRACKET there are letters marked "R" and "L". For **Right Hand** door install the Arm Stop/Spring Cushion Stop in the hole on the "**R**" side.

For **Left Hand** door install the Arm Stop/Spring Cushion Stop in the hole on the "**L**" side.

The Arm Stop /Spring Cushion Stop can be secured with the 5/32" (4mm) Hex wrench provided in the screw pack.

Arm Stop /Spring Cushion Stop /Filler Plug Accessories



INSTALLATION SEQUENCE

LEFT HAND DOOR SHOWN- RIGHT HAND DOOR OPPOSITE

CAUTION

IMPROPER INSTALLATION OR REGULATION MAY RESULT IN PERSONAL INJURY OR PROPERTY DAMAGE. FOLLOW ALL INSTRUCTIONS CAREFULLY.

Illustration 1

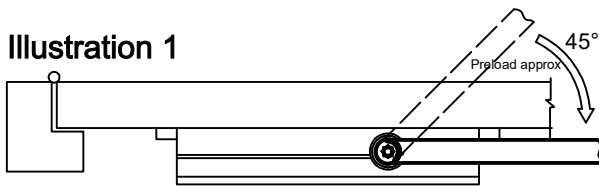

INSTALLATION INSTRUCTIONS

1. Using template dimensions shown above. Mark FOUR (4) HOLES ON DOOR for door closer and FOUR (4) HOLES ON FRAME for parallel bracket.
2. Mount closer on door using screws provided. Latch and sweep speed adjusting valves **MUST BE POSITIONED AWAY FROM HINGE EDGE**
3. Use a wrench or extra arm to turn the bottom end shaft ~45° and put the main arm on the upper end shaft. Make sure the main arm is parallel with the door- See Illustration 1.

IMPORTANT REMARKS

DO NOT allow door to slam into frame.

A normal standard closing time from 90° open position is 5 to 7 seconds evenly divided between main closing (Sweep) and Latching speed. Adjust the SWEEP speed first, then adjust the LATCHING speed.

For slower closing speed of door, turn adjusting valve "S" clockwise and counter clockwise for faster speed.

Latching speed is controlled in the same manner as Sweep speed adjustment.

ADJUSTABLE BACKCHECK FUNCTION

This function is essential to proper operation of CUSH Type arm. Adjust enough to prevent arm from striking stop with impact. See page 1.

ATTACH COVER (if supplied)

Install cover securely using screws provided.

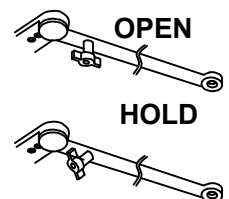

HOW TO HOLD OPERATION (if applicable)

A quarter turn on the HOLD-OPEN CONTROL HANDLE engages or disengages hold-open.