



Profiled

E - SERIES

**ELEVATOR LINEAR
LIGHTING SOLUTIONS**

INDOOR/OUTDOOR

230V AC

You inspire, We innovate.

Who We Are

Profiled Group is a pioneering and world-leader provider of driverless flexible linear lighting solutions. The Group was founded in Spain in 1984 and now operates globally with an R&D Center in Hong Kong and production facilities in Shenzhen. Our high-performance, direct line-voltage solutions, are engineered to perform in very different environments: from high-visual-comfort indoor commercial applications, to the most demanding environments such as construction sites and tunnels.

Blending European design with Asian manufacturing excellence, we engineer lighting systems that are innovative, robust, and future-ready.

Our Philosophy

Your toughest challenges drive our creativity. When standard lighting solutions fail, we step in with tailor-made technology that pushes boundaries. Innovation is not our goal—it's our habit.

Vision

To Illuminate the Future.

We envision a world where lighting is intelligent, flexible, and sustainable—adapting to people, spaces, and the environment in real time.

Mission

To revolutionize linear lighting through our proprietary driverless, solderless, and durable solutions—delivering safety, simplicity, and sustainability to different industries.

Guided by our commitment to excellence, we partner with clients through strategic advisory and superior product ecosystems, delivering high-end lighting innovations that fundamentally elevate human-environment interactions.

Our Technology

We Create What
Others Can't Imagine



DRIVERLESS SIMPLICITY

Direct **LINE-VOLTAGE** connectivity eliminates the need for external power supplies – quicker, safer, and more simple installation. No drivers, no hassles.

INFINITE LENGTH

Ultra long-run LED flexible linear lighting solutions **up to 500m** with only one power input.

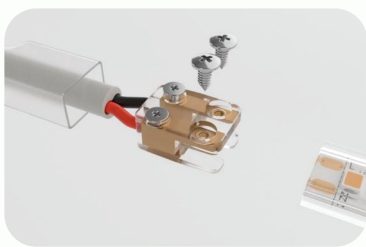
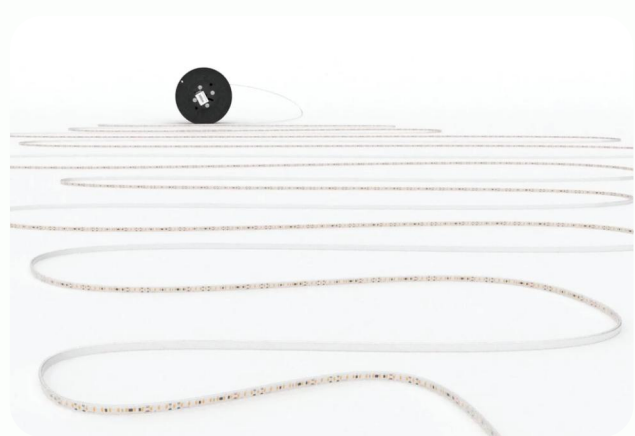

Solderless

Our in-house solderless connectors ensure a **SMOOTHER, QUICKER and SAFER INSTALLATION** without the common issues caused by poor soldering.



Encapsulations

We adapt our materials according to the environment they are used in, **PRIORITIZING THE SAFETY AND HEALTH** of users.



Customizability

We're not selling products—we are here to listen to your needs and offering tailored **SOLUTIONS**.

Driverless.
Endless.
Magical.

ELEVATOR LIGHTING SOLUTIONS

FOR INDOOR/OUTDOOR

Profiled

APPLICATION







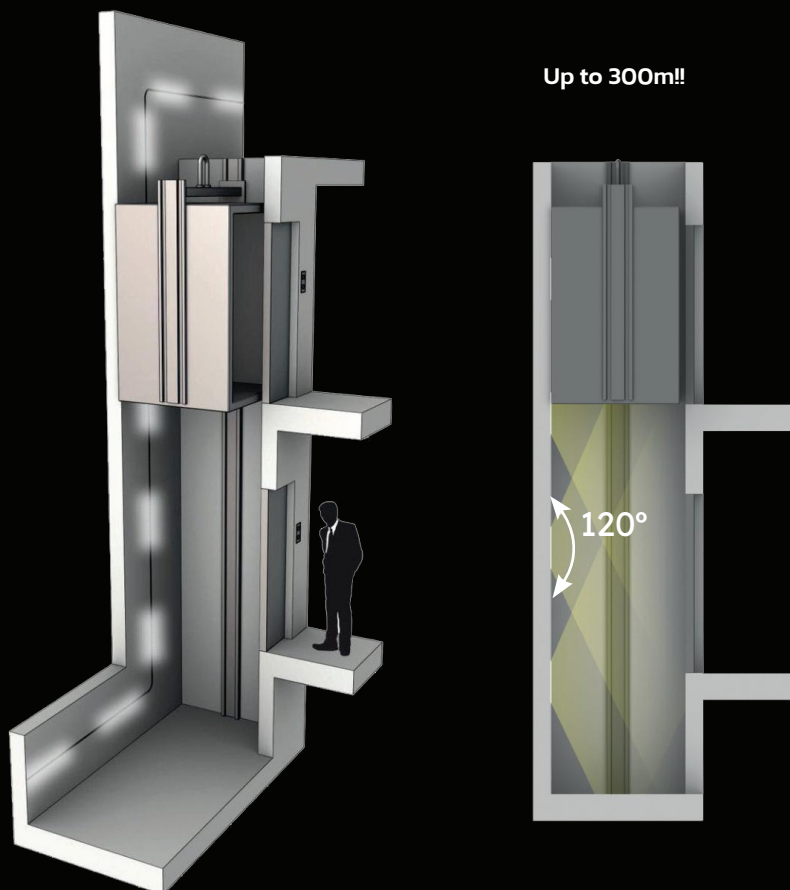





- Elevator Shafts

E-Series specifically designed for elevator shafts offer up to 300 meters of continuous illumination from a single power connection. Easy to install and significantly more cost-effective than traditional lighting, our products adhere to international lighting and elevator standards. Designed for durability and reliability, we provide consistent, high-quality lighting, ensuring safety and efficiency in every installation.

EN81-20/50
COMPLIANT





 >90lm/W	 300m Linkable	 Discontinuous Light	 Power Factor >0.9
 IK08	 IP65	 Anti-Glare Frosted Cover	 UV & Chemical Resistant
 Driverless Solution	 EMC TESTED	 Patented	 Low Flicker

ELEVATOR SERIES - E30/E60

The Elevator Series delivers up to 300 meters of continuous, energy-efficient lighting, no drivers needed. Designed specifically for elevator shafts and hoistways, it offers quick installation, uniform illumination, and minimal maintenance compared to traditional lighting systems.

ELEVATOR LINEAR LIGHTING SOLUTIONS

Indoor/Outdoor

Ref. **ELEVATOR SERIES - E30/E60**



LIGHT DISTRIBUTION

E30

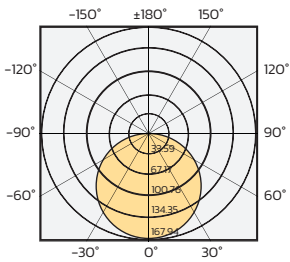

E60

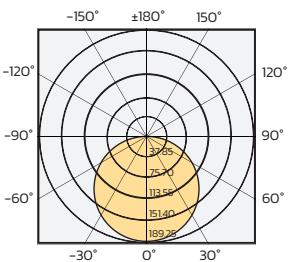

SPECIFICATIONS

Article No.	E30	E60
W/m	3,3	6,4
Lumen/M	300	600
Lumen/W	90	93
Shaft Area (m ²), in compliance with (EN-81)	3,5	9,2
LEDs/m	9	14
CCT	6000K	
Voltage	230 V AC ± 10%	
Power factor	>0,9	
Lifetime (L70, B10)	30.000h	
Beam angle	120°	
CRI	>80	
IK	08	
IP	65	
Ambient temp	-20 - + 45 °C	
Input cable	Bare cable ends/Power cable optional	
Material	Anti-glaring frosted silicone	
Maximum length	300m	
Cutting length	500mm	
Approval	EN81-20/50	

WIRING GUIDE

(E30)

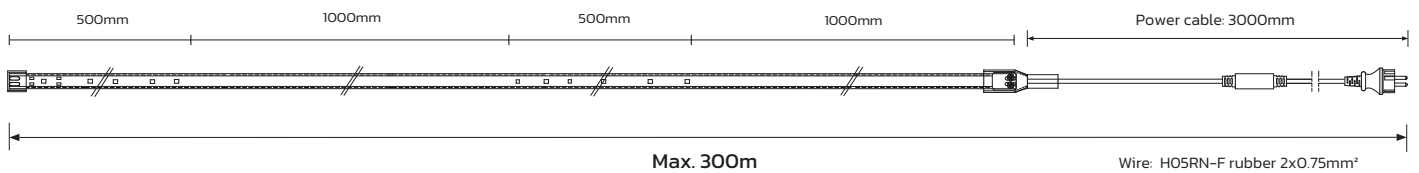

(E60)

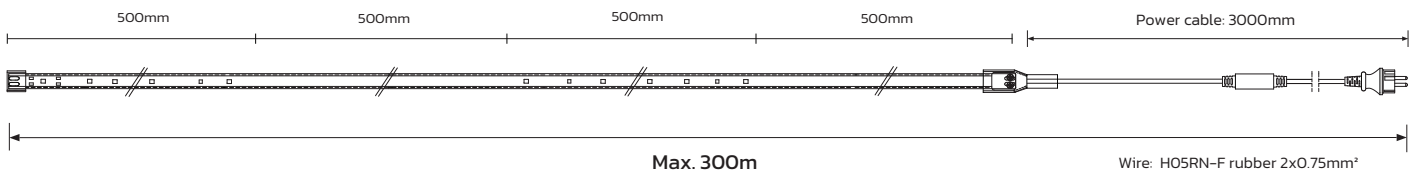

INSTALLATION METHODS



Cable ties



Wall plugs

DIMENSIONS

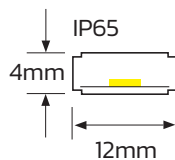

PACKING INFO (E30/E60)

Reel	Size(mm)	Weight(kg)
300m	Ø400 x H200	16

INSTALLATION MANUAL

Profiled provides all the components and accessories needed for installation and power connection. The connectors are designed with the patented Profiled technology. We recommend the use of our components and accessories in order to assure the correct performance of the system.

	End Cap		Screwed Set		LED Strip tensor
039020	Isolate the LED strip termination	039049	Led strip mechanical and electrical connection with caps to cover screws and led sealant	039039	Element that provides tension to the LED strip
	EU Power black cable 10m		EU Power black Cable 0.75m		Led Sealant
039063	Provides the strip with power	039062	Provides the strip with power	039074	Sealant that provides proper insulation

GENERAL CONSIDERATIONS

DO NOT modify, deform or cut the strips or any of the components provided by Profiled. Profiled AC strips are designed to work directly plugged into an AC source. No power supply mean is needed. To avoid any malfunctions of the system, and to protect against electrical shock, fire, or physical injury, please observe the following: This system has been designed to work with 230 V AC current. Connection to a line voltage other than that may create a safety and fire hazard and may damage the system. If you are unsure of the type of power supply, consult your local power company or qualified service technician.

TO AVOID ELECTRICAL SHOCK and/or damage to the system, do not handle the components with wet hands. Always make sure the LED Cable strip is disconnected from the power source before cutting, connecting, mounting, or modifying in any way.

DO NOT operate with the LED strip tightly coiled. Do not puncture, cut, shorten, or splice the LED strip (except where marked). Do not step on the strip or apply any mechanical stress on the strip. For outdoor use, make sure that all connections and the end cap in the last segment are tightly secured to preclude the entry of water.

DO NOT look directly into the LEDs when lit. They are powerful and could damage your vision.

ONLY AUTHORIZED PERSONNEL must handle and install the strips. Follow the national electric codes and regulation during installation.

For more detailed information of the product please refer to the Profiled product catalogue or contact us in case of any questions.

When handling or during installation **DO NOT** twist the strips or bend it in the wrong direction.

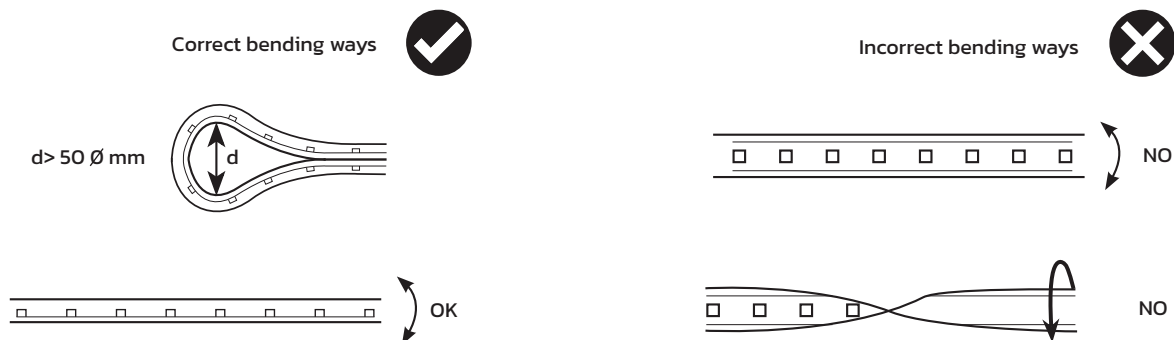

INSTALLATION

1. PREPARATION

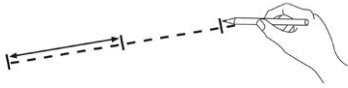

Measure the installation and mark the holding points. Make sure to take measurements in case of any extra areas to be illuminated (e.g., machinery areas).

2. CUT

Cut the strips using a sharp tool only on the indicated areas.

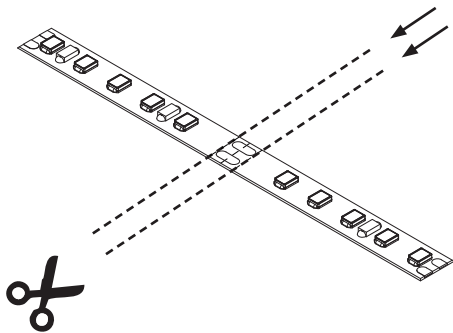

Make sure again that the length of the strip is sufficient to illuminate the shaft and additional areas if needed (i.e. machinery areas).

3. STRIPS CONNECTIONS



IMPORTANT
For safety reasons, follow these instructions before connecting the strip to the power source.

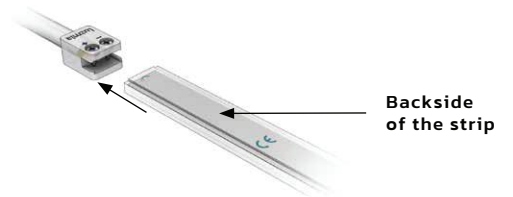

Insert the extreme of the strip inside the connector as indicated above. The LED strip must be inserted in the connector with LEDs facing down.

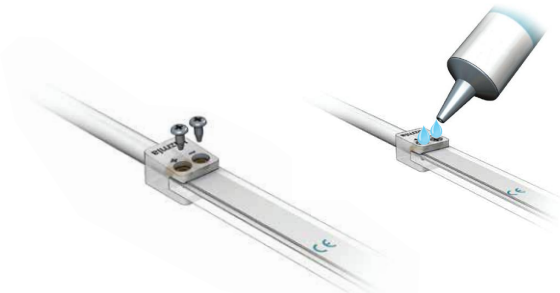

Screw the connector to the strip and apply sealant on top of the screws.

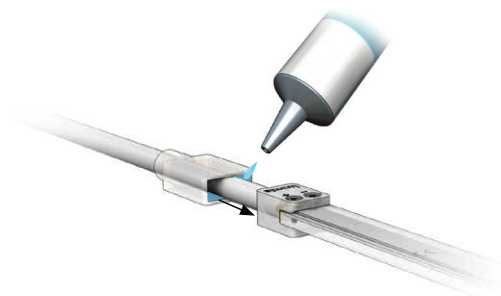

Apply sealant and insert the silicone end cap covering the connector and the strip as shown above.

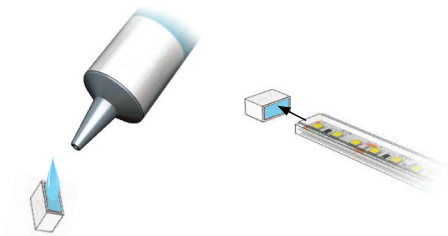

For safety reasons, the end of the strip must be covered with the silicone end cap. Apply sealant and insert the strip in the cap.

4. FIXING

4.1 USING PROFILED'S TENSOR

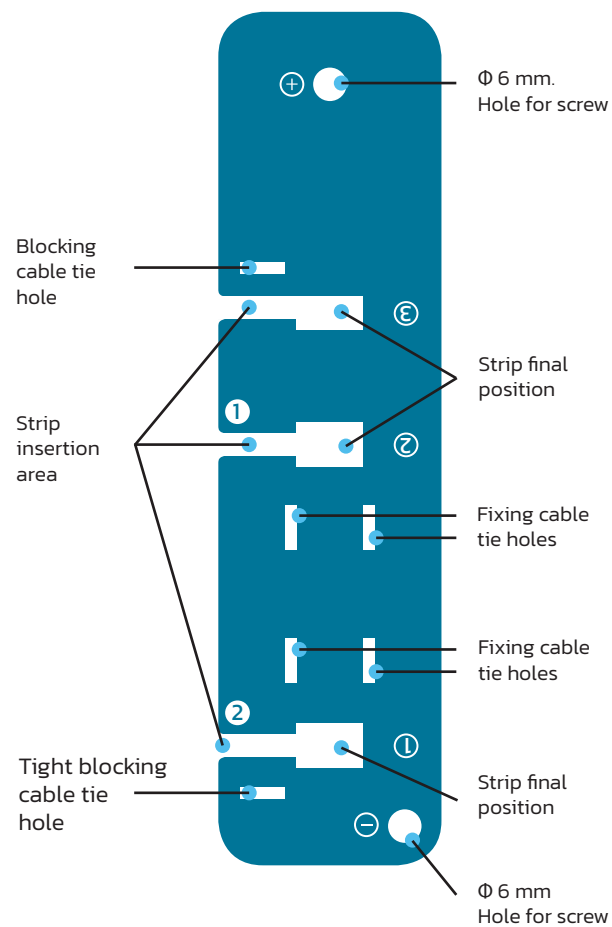

5.1.1 TOP FIXTURE

Put the strip through the insertion areas until the final position as indicated in the drawings on the right (first ① and then ②).



IMPORTANT!

Use the area of the strip without LEDs to fix the strip in the tensor.



5.1.2

Insert and tighten the blocking cable tie. This cable tie will assure the correct position of the strip.

Insert the fixing cable ties wrapping the strip with the tensor. Do not tighten the cable ties yet.

Make sure that the length of the remain strip is enough to lighten the additional areas if needed.

Recommended cable tie size 250×5mm (L×W).



Tight blocking cable tie

Loose fixing cable ties

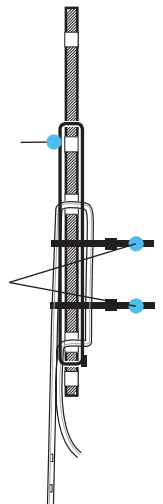

5.1.3

Screw the tensor into the desired position on the wall using the diameter 6mm hole (⊕).

Make sure that the LED strip is in the right position and close tight the fixing cable ties.

Screw the tensor on the wall using the diameter 6mm hole (⊖).

In case any additional area needs to be illuminated, use wall plugs and cable ties to fix the strip (distance between wall plugs for horizontal sections 0.5m and 1.5m for vertical sections).



Tight fixing cable ties

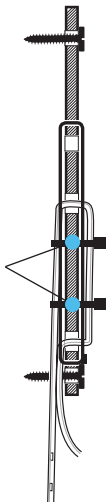

5.1.4 BOTTOM FIXTURE

Below the already fixed top tensor, put the strip through the bottom tensor as shown in the image. Attach a rope to the diameter 6mm hole (**+**).

This rope must be at least the same length as the height of the elevator shaft.

From the bottom of the shaft, pull the rope bottom together with the bottom tensor in order to place the strip in the correct position. Once the bottom tensor is in the desired position, remove the rope and proceed to fix it as follows.

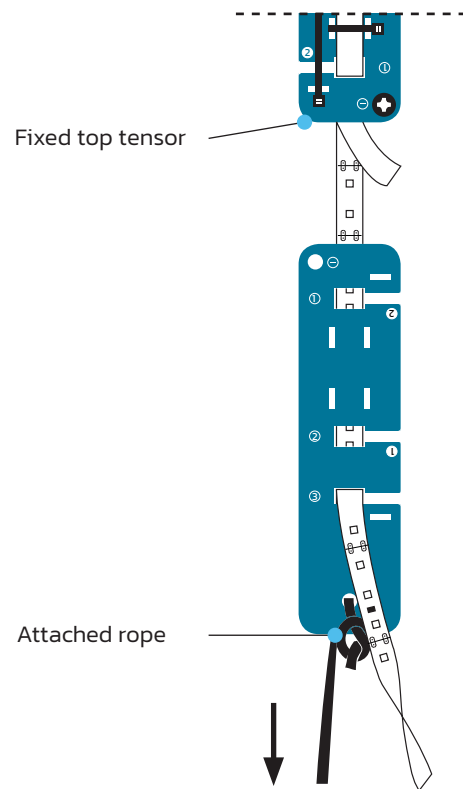

5.1.5

Put the strip through the insertion areas until the final position as indicated in the drawings on the right (first **1** then **2** and finally **3**).

Insert and tighten the blocking cable tie. This cable tie will assure the correct position of the strip.

Insert the fixing cable ties wrapping the strip with the tensor. Do not tighten the cable ties yet.

Screw the tensor on the desired position of the wall using the diameter 6mm hole (**+**).

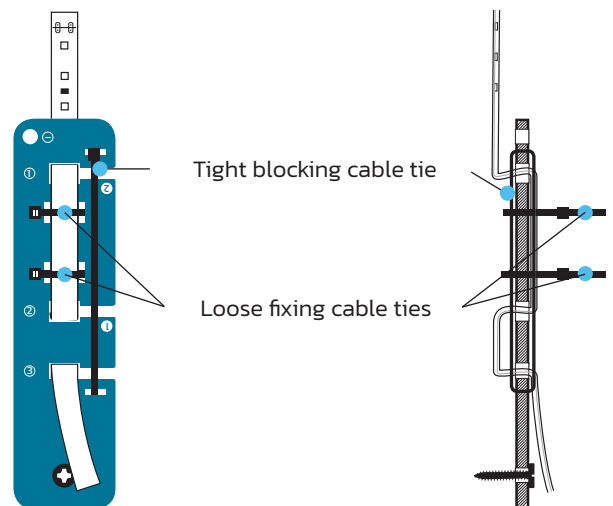

IMPORTANT!

Use the area of the strip without LEDs to fix the strip in the tensor.

5.1.6

Make sure that the LED strip is in the right position and close tight the fixing cable ties. Screw the tensor on the wall using the diameter 6mm hole ().

Make sure that the cable ties are properly tightened and the length of the remain strip is enough to lighten the additional areas.

In case of any other additional area need to be lightened, use wall plugs and cable ties to fix the strip (distance between wall plugs for horizontal sections 0.5m and 1.5m for vertical sections).

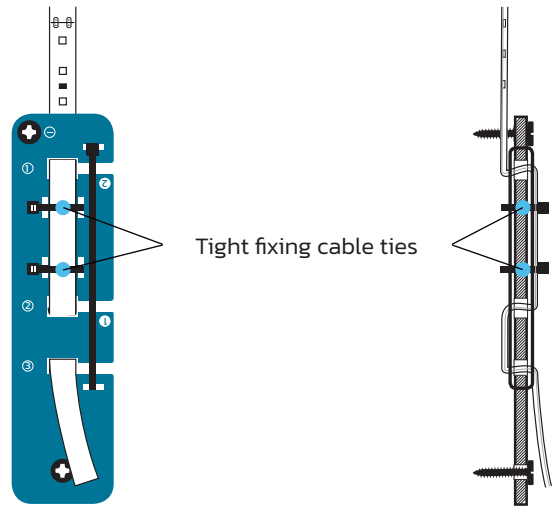

5.2 USING WALL PLUGS

In case of using wall plugs to fix the strip to the wall make sure that the distance between plugs is 1.5m for vertical sections and 0.5m for horizontal sections.

Cable ties must be fixed in the areas of the strip without LEDs.

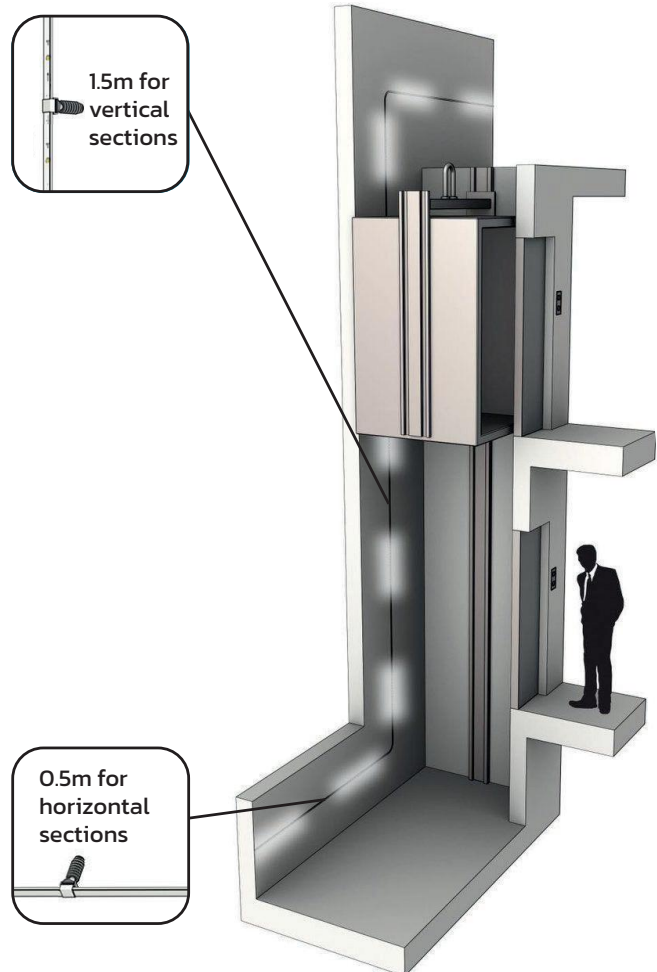

R&D Center

Unit 1901B, 19F, Allied Kajima Building,
138 Gloucester Road,
Wanchai, Hong Kong S.A.R.

Production Facilities

Room 302, 3/F (west side), Building F,
Fuanna Industrial Park, No. 1 Qingning Rd.,
Qinghu Community, Longhua District,
Shenzhen 518109, China.

www.profiled-group.com
info@profiled-group.com
+852 2369 9678

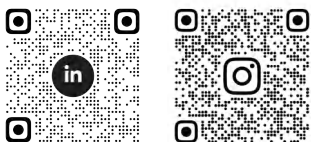

Profiled

www.profiled-group.com