

**SERVICE & INSTALLATION MANUAL OF REFRIGERATION  
& FREEZING TABLES AND REACH-INS**



AN 401 T/F	AN 902 T/F	AN 904 T/F	AN 401 BT	AN 902 BT	AP 401 T/F	AP 902 T/F	AN 401 PAST
AN 902 PAST	AN 501 T/F	AN 1002 T/F	AN 501 BT	AN 1002 BT	AN 502 T/F	AN 1003 T/F	AN 1004 T/F
AN 502 BT	AN 1003 BT	AN 1004 BT	AN 502 MX	AN 1002 MX	ANDP 1003 TF/G	ANDP 1004 TF/G	ANDBT 1003 TF
ANDBT 1004 TF	AEX 500 T/F	AEX 1000 T/F	AEX 1600 T/F	AN 501 BT CR	AN 1002 BT CR	AN 501 SC	AN 1002 SC
AN 1603 T/F	AN 1605 T/F	AN 1606 T/F	AGN 301	AGN 602	AGN 301 BT	AGN 602 BT	AGN 602 MX
AGN 302	AGN 603	AGN 604	AGN 300 CR	AGN 600 CR	AGB 651	AGB 1302	AGB 651 BT
AGB 1302 BT	AGB 701 A	AGB 701	AGB 1402	AGB 701 BT	AGB 1402 BT	AGB 702	AGB 702 BT
AGB 1403	AGB 1404	AGN 702 MX	AGB 1402 MX	AGB 701 CR	AGB 1402 CR	AGB 701 BT CR	AGB 1402 BT CR
AGB 701 PESC	AGB 1402 PESC	AGB 701 PAST	AGB 1402 PAST	AGB 701 BT PAST	AGB 1402 BT PAST	AGB701 MDA	AGB 1402 MDA
AGB 701 MDAB	AGB 1402 MDAB	AGB 901	AGB 901 BT	FC 900 BT	AC 600 R	AC 600 BT	FGB701
FGB701N	FGB1402	FGB1402N	RIC 1P	RIC 2P	RIC1P TH		

BMPP 1500 II	BMPP 2000 II	BMPP 2500 II	BMPP 1500 BT	BMPP 2000 BT	BMPP 2500 BT	BMPP 1500 CR	BMPP 2000 CR
BMPP 2500 CR	BMPPF 1500 II	BMPPF 2000 II	BMPPF 2500 II	BMPP 1500 GR	BMPP 2000 GR	BMPP 1500 GRBT	BMPP 2000 GRBT
BMPP 1500 EN	BMPP 2000 EN	MSG 1000	MSG 1400	MSG 1600	MSG 2000	MSG 2400	BMGN 1470 II
BMGN 1960 II	BMGN 2450 II	BMGN 1470 BT	BMGN 1960 BT	BMGN 2450 BT	BMGN 1470 CR	BMGN 1960 CR	BMGN 2450 CR
BMGN 1470 F	BMGN 1960 F	BMGN 2450 F	BMGN 1470 GR	BMGN 1960 GR	BMGN 2450 GR	BMGN 1470 GRBT	BMGN 1960 GRBT
BMGN 2450 GRBT	BMGN 1470 PDC	BMGN 1960 PDC	BMGN 1470 EN	BMGN 1960 EN	MPG 1490	MPG 1980	ME 1003 VIP
ME 1000 BAN	ME 1000 EN	ME 1000 II	ME 1000 PIZZA	ME 1000 KB	ME 1003 BAN	ME 1003 EN	ME 1003 II
ME 1003 PIZZA	ME 1003 KB	MR 1620	MR 2190	MR 2750	MR 1620 BT	MR 2190 BT	MR 1620 CR
MR 2190 CR	MR 2750 CR	MR 1620 GR	MR 2190 GR	MR 2750 GR	MR 1620 PDC	MR 2190 PDC	MR 1620 PDCR
MR 2190 PDCR	MR 1620 EN	MR 2190 EN	MEV 1000	MEV 1500	MPL 1740	MPL 2300	MP 1740
MP 2300	MP 1740 CN	MP 2300 CN	FMPP 1500 II	FMPP 2000 II	FMPP 2500 II	FMPP 1500 CR	FMPP 2000 CR
FMPP 2500 CR	FMPP 1500 GR	FMPP 2000 GR	FMPP 2500 GR	MCAF 820	MCAF 1000 CD	MCAF 1000 CI	MCAF 1500
MCAF 2000	MCAF 2500	ME 30/1000	ME 30/1500	ME 30/2000	ME 30/2500	ME 60/1000	ME 60/2000
ME 60/2500	MT 60/1000	MT 60/1500	MT 60/2000	MT 70/1000	MT 70/1500	MT 70/2000	

## REFRIGERATING AND FREEZING REACH-INS AND UNDERCOUNTERS SERVICE AND INSTALLATION MANUAL

### INDEX

<b>1.</b>	<b>General Information</b> .....	20
<b>2.</b>	<b>Safety Precautions</b> .....	20
<b>3.</b>	<b>Serial data plate</b> .....	21
<b>4.</b>	<b>Reception and inspection</b> .....	22
<b>5.</b>	<b>Installation</b> .....	22
5.1.	Location .....	22
5.2.	Unpacking .....	23
5.3.	Ventilation .....	23
5.4.	Leveling .....	24
5.5.	Initial Cleaning Procedure .....	24
<b>6.</b>	<b>Electrical instructions</b> .....	25
<b>7.</b>	<b>Startup procedure</b> .....	26
<b>8.</b>	<b>Operation</b> .....	26
8.1.	Loading product .....	26
<b>9.</b>	<b>Accessories</b> .....	27
9.1.	Shelving installation .....	27
9.2.	Casters installaton .....	27
<b>10.</b>	<b>Maintenance, care and cleaning</b> .....	28
10.1.	Cleaning Recommendation .....	28
10.2.	Replacements and technical service .....	30
<b>11.</b>	<b>Trouble shooting chart</b> .....	31
<b>12.</b>	<b>Warranty management</b> .....	33
12.1.	Warranty certificate .....	34



## 1. GENERAL INFORMATION

This manual was made in an easy way so that you can know how our furniture works and how they should be maintained. A carefully reading is recommended, and it should be consulted in case of any doubt.

The manufacturer is not liable for damages to people or objects that may be caused by non-compliance with the prescriptions contained in this manual. To know all the advantages of this device, please read carefully before proceeding to install it. Anyone who uses this device is recommended to read this user manual. In case of any doubt consult your distributor.

This product has been manufactured under strict quality controls and meets all the requirements established by Infrico. Before leaving the factory, each unit has been tested, guaranteeing its quality. This equipment has been manufactured with recyclable materials, through a productive process that respects the environment.

This furniture complies with directive 2014/30/UE and 2014/35/UE. In addition, the CEI EN 60335-1, CEI EN 60335-2-89, EN 61000-3-2, EN 61000-6-1 y EN 61000-6-3 standards have been applied.



**WARNING!** This device must only be used for the purpose described in this manual.



The electrical/electronic device must be managed at the end of its useful life by an authorized manager.

## 2. SAFETY PRECAUTIONS

**IMPORTANT:** See the **TECHNICAL LABEL** inside of the furniture in order to find the **REFRIGERANT TYPE**.

**FOR MODELS WITH R290 REFRIGERANT / HYDROCARBONS:**



**PRECAUTION – FIRE OR EXPLOSION RISK. FLAMMABLE REFRIGERANT. ONLY A QUALIFIED TECHNICIAN MUST REPAIR IT. DO NOT DRILL THE REFRIGERANT PIPING.**

When using electrical appliances, basic safety precautions should be followed, including the following:

- This refrigerator must be properly installed and located in accordance with this manual before it is used.
- Do not allow children to handle the device. They could damage the refrigerator and seriously injure themselves.
- Do not touch the cold surfaces in freezer compartments when hands are damp or wet. Skin may stick to these extremely cold surfaces.
- Do not store or use flammable products near the refrigerator.
- Unplug the refrigerator before cleaning and making repairs.

 **NOTE: We strongly recommend that any servicing be performed by a qualified technician.**

### 3. SERIAL DATA PLATE

The technical data plate is a permanently affixed label in the interior of equipment's, which contains important electrical and refrigeration data about your product, as well as its model and serial number.



## 4. RECEPTION AND INSPECTION

- All Infrico products are factory tested for performance and are free from defects when shipped.
- When you receive your device, it should be carefully examined in order to detect any possible damage caused during delivery.
- If damage is detected, you should save all the crating material and make note on the carrier's bill of lading describing the damage. A freight claim should be filled immediately.
- If damage is subsequently noted during or immediately after installation, contact your distributor.



**NOTE: Infrico is not responsible for damage incurred during shipment.**

## 5. INSTALLATION

### 5.1 Location

This unit is intended for indoor use only. Ensure that the chosen location for your equipment provides a properly air circulation, so an efficient refrigeration is guaranteed.

Avoid locations near a heat source, such as ovens, fryers or heaters, as well as direct solar radiation where temperature can reach extreme values. Besides, do not choose a location where temperature and humidity exceed the climatic class specification of the product.

It must allow enough space between the equipment and the side walls, so that the opening lock of doors at 120 ° can be used. The doors must be able to open a minimum of 90° in order to use the maximum available door width.

Furthermore, the floor at the final location must be strong enough to support the total weight of the device plus the maximum product load. Also, it must be levelled and free of vibration. Reinforce the floor if necessary.

## 5.2 Unpacking

These Infrico units are shipped from the factory on a wooden pallet and packaged in resistant wooden or cardboard boxes. The box is attached to the box base with the use of large screws. These should be first removed to avoid scratching the unit when lifting off the crate.

All packaging materials used are environmentally friendly and may be recycled or reused. Actively contribute to the protection of the environment by insisting on packaging recovery and removal methods that are environmentally friendly.



**NOTE: Infrico does not recommend laying the unit down on its front, side or back. However, you must be certain to allow the unit to remain in an upright position afterwards for at least 24 hours before plugging it in so that the compressor oil and refrigerant may settle.**

## 5.3 Ventilation

To assure the maximum efficiency of the device, this must be located in a place that provides a continuous air supply on the device underneath and back sides. We recommend installing the equipment 75 mm separated from the wall of each side; we also advise keeping a 300 mm separation between roof and reach-ins top.

Restricting the air supply will generate an excessive heat load on the condensing unit and adversely affect its operating efficiency. Never obstruct the grill area in the front of the cabinet in any way.



**NOTE: Any restriction of the proper air flow, total or partial, will avoid the warranty on the unit.**



300 mm minimum space at the front of the unit, for AN models



300 mm minimum space at the top and front of the unit, for AGN/AGB models



300 mm minimum space at the front of the unit, for undercounters

#### 5.4 Leveling

It's extremely important that the cabinet is perfectly levelled for proper operation so that the drain pan will drain properly, the doors will line up with the frames and the unit will not be subjected to undue strains.

This model are supplied with height adjustable legs (180 mm maximum height). In this case, to operate in a stable condition, ensure the floor where the unit is located is levelled.

Optionally, casters can be supplied for any model. In this case, in order to operate in a stable and levelled condition, the front casters must be locked. In the "Casters installation" section you will find detailed information about casters adjustment.

#### 5.5 Initial cleaning procedure



**NOTE:** This sticker shows the procedure to be followed for the device exterior conservation.



Before the startup and loading product inside of the device, you should retire the protective plastic layer that covers the furniture and cleaning it. If adhesive rests are left, they should be eliminated with alcohol. It is

**DISTINGUIDO USUARIO:**

ELIMINE EL PLÁSTICO PROTECTOR A LA MAYOR BREVEDAD POSIBLE PARA UNA BUENA CONSERVACIÓN DEL ACERO.  
SI QUEDASEN RESTOS DE ADHESIVO, ELIMINELOS CON ALCOHOL.  
LIMPIE TODO EL APARATO CON AGUA Y JABÓN NEUTRO, SECÁNDOLO DESPUÉS.

**CHER USAGER:**

VEUILLEZ RETIRER LE FILM PROTECTEUR DES QUE POSSIBLE POUR PERMETTRE UNE MEILLEURE CONSERVATION DE L'ACIER.  
ELIMINEZ LES ÉVENTUELS RESTES AVEC DE L'ALCOOL À BRÛLER.  
NETTOYEZ L'APPAREIL AVEC DE L'EAU ET UN SAVON NEUTRE, PUIS SÉCHEZ.

**DISTINGUISHED USER:**

ELIMINATE THE PLASTIC PROTECTIVE TO THE GREATER POSSIBLE BRIEFNESS FOR A GOOD CONSERVATION OF THE STEEL.  
IF EXIST ADHESIVE REMAINS, ELIMINATE THEM WITH ALCOHOL.  
CLEAN ALL THE APPLIANCE WITH WATER AND NEUTRAL SOAP, DRYING IT AFTER.

recommended to clean all stainless-steel surfaces of the furniture with warm water and a little neutral soap. After cleaning, a rinsed with abundant water and a drying with a soft cloth is recommended.

 **NOTE:** Never use harsh or abrasive cleaners, concentrated detergents, solvents or chemicals to clean the equipment. Remember that products with bleach or ammonia are very dangerous for steel surfaces. Avoid iron particles contamination over steel surfaces.

## 6. ELECTRICAL INSTRUCTIONS

The supply voltage should be checked before connection to assure that proper voltage for the cabinet wiring is available. To determine correct unit voltage, please refer to the serial data plate located on an inner wall of the unit. Verify that this information exactly matches the electrical characteristics at the installation location.

 **NOTE:** This sticker is placed on the power supply wire. It prevents us from the electrical risk of the device.

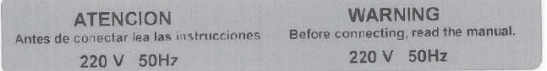

 **NOTE:** The device must be plugged in to an exclusive circuit for this purpose. The violation of this requirement results in warranty cancellation.

 **NOTE:** The unit is designed to operate with a voltage fluctuation of 5% of the voltage indicated on the cabinet serial data plate. Burnout of the compressor due to exceeding the high or low voltage limits will automatically void the factory warranty.

Devices are provided from factory with cord and plug as shown in the figure. If the correct electrical outlet is not provided, you should previously install it.



 **WARNING!:** Any alterations to this cord and plug could cause an electrical hazard and will void the factory warranty.

 **WARNING!:** Infrico will not warranty any units that are connected to an extension cord.

## 7. STARTUP PROCEDURE

After the cabinet has been installed, levelled, cleaned and electrically connected in accordance with this manual, it is ready to operate. Simply plug the unit in to begin operation.

The system should run smoothly and quietly in accordance with generally accepted commercial standards. If any unusual noises are heard, turn the unit off immediately and check for any obstructions of the fans.

All cabinets must be given enough time to reach normal operating temperature before placing any product inside cabinet. Continuous opening and closing of the doors will hamper the unit's ability to maintain optimum refrigeration performance.



**NOTE: Before loading product, we recommend to run the unit empty during 24 hours.**



**NOTE: If the device is disconnected or shut off, wait five minutes before starting it again.**

## 8. OPERATION

To see about the reach-ins and undercounters digital controller functioning, consult the attached manual.

### 8.1 Loading product

- Before introducing food into the cabinet, it is advisable to leave it empty while in operation until it reaches the working temperature. Once this has been reached, you can proceed to load the product.
- When introducing food, enough space must be left between the goods to enable air circulation.
- Never allow the goods to prevent doors from closing.
- Do not exceed the maximum weight per shelf of 25 Kg. In gusset-reinforced shelves, there can be loaded up to 75 Kg.
- Do not exceed the maximum weight per drawer of 40 Kg.
- Do not obstruct the fan with the load and assure that this never exceeds the maximum load level determined. The load must therefore always be situated underneath the fans.
- Never put hot food in the cabinet.

- If the cabinet is going to remain shut down for prolonged periods, try to leave it unplugged, empty, clean and with door ajar.
- Food or drinks must be properly wrapped or stored in hermetic containers in order to avoid smells inside the unit. Besides, it should be considered that the presence of not properly wrapped food inside the chamber can cause the evaporator corrosion.



**WARNING!: Corrosion problems due to unwrapped food inside the device, cause the warranty cancellation.**

## 9. ACCESORIES

### 9.1 Grills

All equipment is supplied with rails, supports and grills, except AGB reach-ins, which have stamped rails and grills; all bakery reach-ins, which are only supplied with rails and fish reach-ins, which have rails and containers. Supports are easily removable for their cleaning, and rails are height adjustable.

### 9.2 Casters installation

This models are supplied with adjustable legs. Nevertheless, casters installation is a possible option. For the legs replacement and casters installation, these steps must be followed:

- Lay the unit down on its back carefully.
- Move the legs away by unscrewing them.
- Put casters over the same holes and screw them.
- Ensure the good ajustement of casters.
- Once casters are checked, return the device to its vertical position carefully.



**WARNING!: Once casters are installed, the device must keep vertical for 24 hours before beeing connected, in order to assure the oil return to the compressor.**

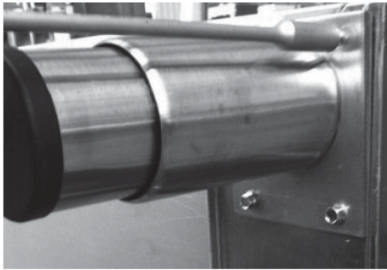

Unscrew the legs



Screw the casters in the same holes and ensure that the device is correctly levelled.

## 10. MAINTENANCE, CARE AND CLEANING

### 10.1 Cleaning procedure

#### Cleaning the cabinet

To clean the cabinet, the following instruction should be followed:

- Disconnect the unit from the power supply and remove all food products from inside.
- Open all doors and allow the cabinet to reach room temperature. Remove all accessories and clean them with a baking soda or mild soap and warm water solution. Dry all the accessories completely with a soft clean cloth.
- Once the cabinet has reach room temperature, wash the entire cabinet inside and outside with a baking soda or mild soap and warm water solution. Rinse thoroughly with clear water and dry with a soft clean cloth. Failure to dry all surface completely may cause water stains. There are also stainless-steel cleaners available which can restore and preserve the steel's surface protective layer.
- Return all accessories to their initial positions and plug the unit in.
- Early signs of stainless steel breakdown can consist of small pits and cracks. If this has begun, start to apply stainless steel cleaners in order to restore the passivity of the steel.
- Many product foods have an acidic content which can attack stainless steel, such as mustard, mayonnaise, lemon juice, tomatoes and other vegetables, and every food which contains salt.



**NOTE: Never use steel pads, wire brushes or scrapers to clean the cabinet.**

 **NOTE:** Cleaning solutions need to be alkaline based or non-chloride cleaners. Any cleaner containing chlorides will damage the protective film of the stainless steel.



#### Door gaskets maintenance

- Door gaskets require a regular cleaning that protects its elasticity, in order to guarantee an appropriate closure and prevent from the growth of molds. Door gaskets can be cleaned with soapy water. Avoid the use of strong cleaners and sharp utensils.
- Door gaskets can be easily removed by removing them from the edge of the door and replacing them by pressing them against it.

 **NOTE:** if the door gasket is contaminated with fat and is not cleaned, it will lose its elasticity and will break soon.

#### Cleaning the condenser

The condenser, which is located behind the rear or frontal panel grill, depending on the model, must be checked periodically, at least every **6 months**. The frequency of cleaning depends on the operating environment. Air must be able to freely circulate through the condenser, so the surface of the condenser must be kept free of dirt and fat for proper system operation. Dirty condensers result in functioning failure and product loss. If the condenser coil is dirty or blocked, follow this instruction:

- Disconnect the power supply.
- Remove the lower grill on the rear of the cabinet.
- In some models it would be necessary to retire the screws that adjust the condenser unit to the skirting, and extract it in order to clean the condenser.
- If the condenser has a protective case, you must unscrew and extract it.
- Once that condenser's surface is free, it should be cleaned using a soft brush or a vacuum. Never use a wire brush.
- Heavier dust builds up may require compressed air to blow through the condenser.
- Once it is cleaned, reintroduce the protective case, return the condenser unit to its original position and reinstate all the screws.

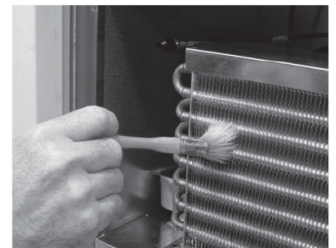

- Finally, replace the lower rear panel and reconnect electrical power supply.



**WARNING!: Never use water for this cleaning procedure as water can damage the electrical components located near the condenser.**

### Doors / hinges maintenance

With the passage of time and the use of the doors, the hinges can move slightly. If you notice that the door is starting to misalign, you must adjust the screws that attach the hinge brackets to the cabinet.

### Drainpipes maintenance

Those units equipped with interior drainpipe for water draining must be checked after cleaning in order to ensure that the drainpipes are free of any obstruction, generally produced by food loading.

### Drawers maintenance

If you decided to configure your device with drawers instead of doors, periodically check if guides slide correctly, and if the final closure mechanism works so that the drawer does not keep open. Also check that drawer's load is not over the recommended level (40 Kg.).

While using low temperature furniture, drawers' guides can be blocked by ice. In order to avoid this effect, we advise to switch off the equipment every 15/20 days for one night so that guides are free of ice.

## 10.2 Replacements and technical service



**WARNING!: Make sure that the appliance is disconnected from the mains before carrying out any maintenance or repair operation. These jobs must be carried out by qualified personnel.**

After performing the pertinent checks, DO NOT MAKE YOURSELF ANY REPAIRS. Contact your Technical Assistance Service, providing the model and serial number of the device (located on the characteristics label),

receive a list of companies that can offer an adequate technical service.

**Servicio Asistencia Técnica Infrico**

**Tel: 00 34 957 51 14 68**

**Fax: 00 34 957 59 51 06**

**Email: sat@infrico.com**

**www.infrico.com**



**NOTE: If you need a spare part, always insist on factory authorized spare parts.**

**11. TROUBLE SHOOTING CHART**

Many operating problems are derived from causes that can be easily eliminated without the need to contact the Technical Department. The following page shows a table with types of problems that may come up, their cause, and how to resolve them.

PROBLEM	POSSIBLE CAUSE	POSSIBLE SOLUTION
The apparatus does not work	<ol style="list-style-type: none"> <li>1. It is not plugged into the electrical socket.</li> <li>2. No electrical current is reaching the plug because the fuse has blown or the automatic power limiter has been tripped.</li> </ol>	<ol style="list-style-type: none"> <li>1. Insert the plug into the electrical socket and check that there is electrical current.</li> <li>2. Replace the fuse or reconnect the automatic power limiter.</li> </ol>
The device is not cooling very much	<ol style="list-style-type: none"> <li>1. Check the cut-off temperature in the controller.</li> <li>2. The door has not been closed properly or has been opened very frequently.</li> <li>3. The device's ventilation grilles have been obstructed.</li> <li>4. Condenser is dirty.</li> <li>5. The device is directly exposed to sunlight or a heat source.</li> </ol>	<ol style="list-style-type: none"> <li>1. Reduce the cut-off temperature.</li> <li>2. Ensure that the door is not kept open for long.</li> <li>3. Keep these areas unobstructed as indicated in the "installation" section of this manual.</li> <li>4. Clean with compressed air or a hard-bristle brush (not a steel one).</li> <li>5. Move the refrigerator to a different location or shield it from the heat sources.</li> </ol>

<p>Noisy operation</p>	<ol style="list-style-type: none"> <li>1. The device is not properly levelled.</li> <li>2. Some of the internal tubes are touching.</li> <li>3. Loose screws in a particular part.</li> <li>4. Condenser or evaporator fan causes vibrations.</li> <li>5. Too low oil charge in compressor.</li> <li>6. Lose parts on condensing unit.</li> </ol>	<ol style="list-style-type: none"> <li>1. Level it as indicated in the “installation” of this manual.</li> <li>2. Separate the tubes in contact.</li> <li>3,6. Tighten the loose screws.</li> <li>4. Level the equipment and tighten any loose screw.</li> <li>5. If equipment was layed down on any of its faces, remain it 24 hours in an upright position without plugging it in, in order that oil returns to compressor. Also check for oil leaks.</li> </ol>
<p>The device creates too much ice in the evaporator</p>	<ol style="list-style-type: none"> <li>1. Doors not properly closed.</li> <li>2. Doors opened too often.</li> <li>3. It has not been defrosted.</li> </ol>	<ol style="list-style-type: none"> <li>1,2. Ensure that the door is not kept open for long.</li> <li>3. Defrost the device.</li> </ol>
<p>Compressor does not start working</p>	<ol style="list-style-type: none"> <li>1. Disconnect switch open.</li> <li>2. Blown fuse.</li> <li>3. Defective wiring.</li> <li>4. Overload protector tripped.</li> <li>5. Open control contacts.</li> <li>6. Defective relay.</li> <li>7. Low gas charge in the system.</li> </ol>	<ol style="list-style-type: none"> <li>1. Close the disconnect switch.</li> <li>2. Replace the blown fuse.</li> <li>3. Check electrical wiring.</li> <li>4. Check if there is an unusual low voltage in the power point.</li> <li>5. Control may be defective, or unit location may be too cold.</li> <li>6. Replace the relay.</li> <li>7. Check for leaks.</li> </ol>
<p>Compressor does work, but stops on overload</p>	<ol style="list-style-type: none"> <li>1. Low voltage.</li> <li>2. Defective unit wire.</li> <li>3. Starting capacitor defective.</li> <li>4. Defective compressor.</li> </ol>	<ol style="list-style-type: none"> <li>1. Check if there is an abnormal low voltage at the power point.</li> <li>2. Check electrical wiring and installation.</li> <li>3. Replace starting capacitor.</li> <li>4. Replace compressor.</li> </ol>
<p>High head pressure</p>	<ol style="list-style-type: none"> <li>1. Overcharged with hot product unit.</li> <li>2. Air or non-condensable gases in system.</li> <li>3. Dirty condenser.</li> <li>4. Defective condenser fan.</li> <li>5. Unit location too hot.</li> </ol>	<ol style="list-style-type: none"> <li>1. Check product temperature and keep it out of the equipment for its chilling, if it is very hot.</li> <li>2. Vacuum seal the system.</li> <li>3. Clean the condenser.</li> <li>4. Replace the condenser fan.</li> </ol>

	<ol style="list-style-type: none"> <li>6. Restriction in expansion valve, strainer.</li> <li>7. Discharge valve partially closed.</li> <li>8. Discharge line obstructed.</li> </ol>	<ol style="list-style-type: none"> <li>5. Move the unit away from very hot locations.</li> <li>6. Adjust expansion valve or strainer.</li> <li>7. Adjust discharge valve.</li> <li>8. Check and adjust discharge line.</li> </ol>
Low head pressure	<ol style="list-style-type: none"> <li>1. Insufficient refrigerant charge.</li> <li>2. Leak in the system.</li> <li>3. Cold unit location.</li> </ol>	<ol style="list-style-type: none"> <li>1. Check for possible refrigerant gas leaks.</li> <li>2. Repair system leaks.</li> <li>3. Move the unit away from very cold locations.</li> </ol>
Compressor short cycles	<ol style="list-style-type: none"> <li>1. Differential control set too close.</li> <li>2. Refrigerant undercharge.</li> <li>3. Refrigerant overcharge.</li> <li>4. Discharge valve leaking.</li> <li>5. Cutting out on high pressure control.</li> <li>6. Dirty condenser.</li> </ol>	<ol style="list-style-type: none"> <li>1. Adjust the differential with the controller.</li> <li>2. Check pressure control.</li> <li>3. Adjust refrigerant level.</li> <li>4. Replace discharge valve.</li> <li>5. Adjust refrigerant charge to avoid overpressures.</li> <li>6. Clean the condenser.</li> </ol>

## 12. WARRANTY MANAGEMENT

Distinguished customer, we inform you of the rules on management of guarantees granted by our company to your products:

- Firstly, we inform you that products manufactured and sold by INFRICO SL are equipment destined for an industrial use, not for domestic use. Because of this, the applied warranty is not regulated by Consumers Law, but by the trade guarantee laws.
- INFRICO SL warranty, covers for the period of **one year** every manufacturing defect or any hidden defect of the product. The warranty that Infrico as a manufacturer gives to its commercial network is based on defective parts replacement sent with the shipping charge paid, being responsibility of the distributor covering the repair warranty (labour and consumables); and, of course, the equipment start-up in the first installation in the establishment.

## Service & Installation Manual

- It is responsibility of the distributors to take care about final users guarantees, requesting INFRICO SL the necessary components for repairs or replacements.
- The warranty does not cover panes breaking after having been delivered by Infrico; nor damaged parts due to a bad use or the normal wear of them.
- If during the first three months of function a fault whose repair is disproportionate in comparison with the device value is detected, there could be conceded the total equipment replacement.
- Any intervention in the device that affects the electrical connection, cooling part or electronic microcontroller not authorized by our SAT (Technical Assistance Service) will result in the loss of the guarantee period remaining of the device.
- If exceptionally the distributor is unable of making a repair, there could be conceded, prior SAT authorization, the gathering of a device for its repair at INFRICO SL facilities, being afterwards returned to the client. If the repair takes place in a period out of warranty, the repair and transport costs will be charged to the client.
- Every SAT authorized return, for its repair or replacement is inspected in our facilities. If different faults than the ones complaint external to our manufacturing or caused by bad use or wear are detected, INFRICO SL will not take charge of the repair or replacement costs, which will be assumed by the client.
- Warranty conditions will not be modified unless prior written agreement is reached with the client regarding the modification of the conditions of the supply contract.

### 12.1 Warranty certificate

Please, complete the following report:

User: \_\_\_\_\_  
Address: \_\_\_\_\_ Tel: \_\_\_\_\_  
Postal code / Town: \_\_\_\_\_  
Distributor: \_\_\_\_\_  
Purchase date: \_\_\_\_\_  
Model: \_\_\_\_\_ Serial No: \_\_\_\_\_  
Compressor No: \_\_\_\_\_

Seller Signature

Purchaser Signature

FOR THE CLIENT

***Ask your distributor to fill in:***

User: \_\_\_\_\_  
Address: \_\_\_\_\_ Tel: \_\_\_\_\_  
Postal code / Town: \_\_\_\_\_  
Distributor: \_\_\_\_\_  
Purchase date: \_\_\_\_\_  
Model: \_\_\_\_\_ Serial No: \_\_\_\_\_  
Compressor No: \_\_\_\_\_

Seller Signature

Purchaser Signature

FOR THE DISTRIBUTOR

# CONTROLLERS FOR REFRIGERATED CABINETS AND DISPLAY UNITS

## EVY232LN3EFXXX1/EVY233LN3EFXXX1



**EPoCA**  
compatible



**PLEASE READ  
CAREFULLY**  
and save this document

**CONSIDER THE ENVIRONMENT**



## INDEX

1.	GENERAL INFORMATION .....	3
2.	MEASUREMENTS AND INSTALLATION .....	3
3.	ELECTRICAL CONNECTION .....	4
4.	FIRST-TIME USE.....	5
5.	USER INTERFACE AND MAIN FUNCTIONS.....	7
5.1.	Switching the device on/off .....	7
5.2.	Unlocking the keypad .....	7
5.3.	Setting the setpoint (if r3 = 0, default).....	7
5.4.	Activating manual defrost (if r5 = 0, default).....	8
5.5.	Manually activating/deactivating the overcooling, overheating and energy-saving functions .....	8
5.6.	Manually switching the cabinet light on/off (if u1c-u5c = 5).....	8
5.7.	Switching the demisting function on (if u1c-u5c = 6) .....	8
5.8.	Switching auxiliary load 1 on/off (if u1c... u5c = 10).....	8
5.9.	Switching auxiliary load 2 on/off (if u1c... u5c = 11).....	9
5.10.	Silencing the buzzer (if u9 = 1, default).....	9
6.	ADDITIONAL FUNCTIONS.....	9
6.1.	Setting the date, time and day of the week (available when the EVlinking RS-485 EVIF23TSX converter, the EVlinking BLE EVIF25TBX module or the EVlinking Wi-Fi EVIF25TWX module is connected)) .....	9
6.2.	Activating the high or low humidity function (if F0 = 5) .....	10
6.3.	Viewing/deleting HACCP alarm information .....	10
6.4.	Viewing the minimum and maximum temperatures saved in the last 72 hours.....	11
6.5.	Viewing/deleting compressor operation days .....	11
6.6.	Viewing the temperature detected by the probes .....	12
6.7.	Starting up the EVlinking Wi-Fi module again .....	12
7.	SETTINGS .....	12
7.1.	Setting configuration parameters .....	12
7.2.	Restoring factory settings .....	13
8.	CONFIGURATION PARAMETERS.....	13
9.	ALARMS .....	23
10.	TECHNICAL SPECIFICATIONS .....	23

## 1. GENERAL INFORMATION

- controllers for normal or low temperature units
- power supply 12... 24 Vdc
- 3 configurable analogue inputs for PTC, NTC or Pt 1000 probes
- door switch digital input
- according to the model, 2 or 3 digital outputs (electro-mechanical relays)
- main relay 30 res. A @ 250 Vac (according to the model)
- two 12... 24 Vdc 2.5 A max. outputs
- sealed relays compliant with the standard EN 60079-15
- alarm buzzer
- TTL MODBUS slave port for the EVconnect app or the EPoCA remote monitoring system
- hot or cold mode regulation

Models available

Purchasing code	Number of relays
EVY232LN3EFXXX1	2
EVY233LN3EFXXX1	3

## 2. MEASUREMENTS AND INSTALLATION

Measurements are expressed in mm (inches). Front installation on a plastic or metal panel (with elastic holding flaps).

-  **N. B:** The metal panel must be between 0.8 and 1.5 mm (1/32 and 1/16 in) thick, while the plastic panel must be between 0.8 and 3.4 mm (1/32 and 1/8 in).

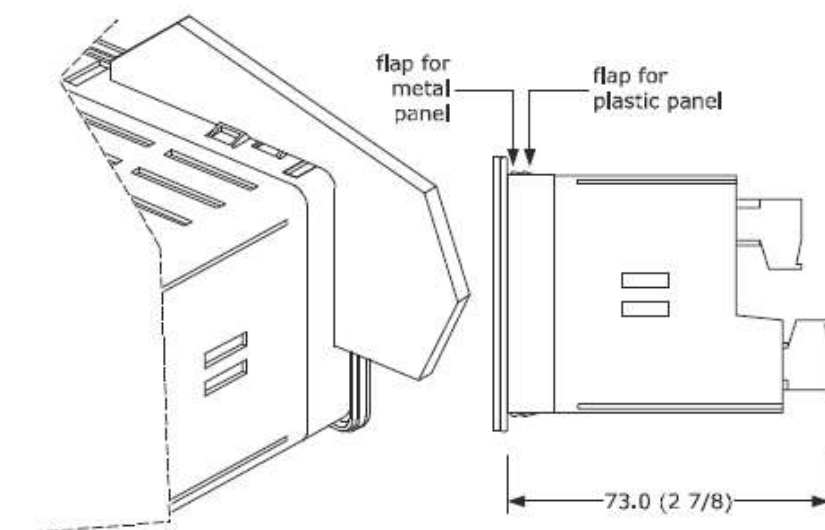



**INSTALLATION PRECAUTIONS**

- ensure that the working conditions are within the limits stated in the TECHNICAL SPECIFICATIONS section
- do not install the device close to heat sources, equipment with a strong magnetic field, in places subject to direct sunlight, rain, damp, excessive dust, mechanical vibrations or shocks
- in compliance with safety regulations, the device must be installed properly to ensure adequate protection from contact with electrical parts. All protective parts must be fixed in such a way as to need the aid of a tool to remove them.

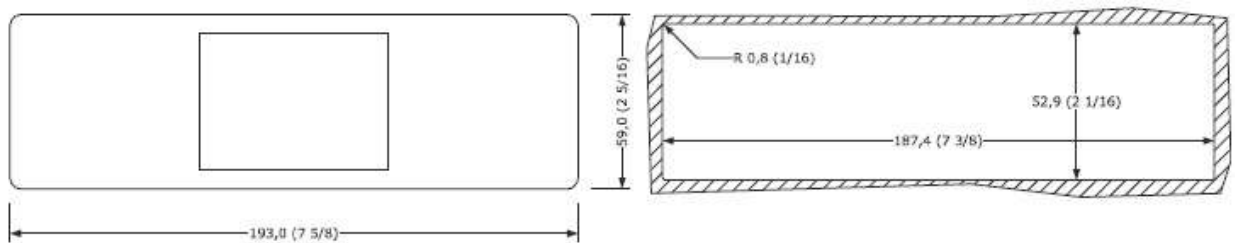

**3. ELECTRICAL CONNECTION**



**N. B.:**

- use cables of an adequate section for the current running through them
- to reduce any electromagnetic interference, locate the power cables as far away as possible from the signal cables
- **if the device is powered at 12 Vdc, the 12... 24 Vdc outputs will supply 12 Vdc 2.5 A max each; if the device is powered at 24 Vdc, the 12... 24 Vdc outputs will supply 24 Vdc 2.5 A max each**

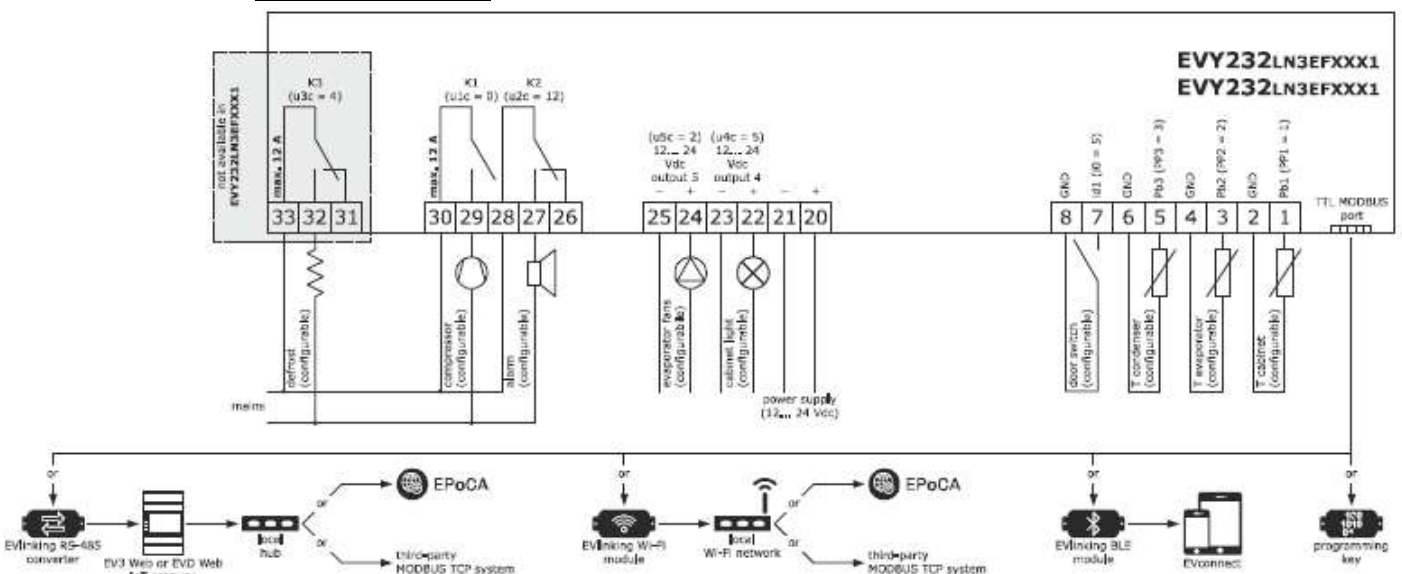



**PRECAUTIONS FOR ELECTRICAL CONNECTION**

- if using an electrical or pneumatic screwdriver, adjust the tightening torque
- if the device is moved from a cold to a warm place, humidity may cause condensation to form inside. Wait for about an hour before switching on the power
- make sure that the supply voltage, electrical frequency and power are within the set limits. See the section TECHNICAL SPECIFICATIONS
- disconnect the power supply before carrying out any type of maintenance
- do not use the device as a safety device
- for repairs and further information, contact the EVCO sales network

**4. FIRST-TIME USE**











1. Carry out the installation following the instructions given in the section MEASUREMENTS AND INSTALLATION.
2. Power up the device: an internal test will start up. The test normally takes a few seconds; when it is finished, the display will switch off.
3. Configure the device as shown in the section Setting configuration parameters. Recommended configuration parameters for first-time use:

PAR.	DEF.	PARAMETER	MIN. – MAX.
SP	<b>0.0</b>	setpoint	r1-r2
P0	<b>1</b>	Type of probe	0 = PTC 1 = NTC 2 = Pt 1000
P2	<b>0</b>	Temperature measurement unit	0 = °C 1 = °F
d1	<b>0</b>	Type of defrost	0 = electric 1 = hot gas 2 = compressor stopped

Next check that the remaining settings are appropriate; see the section CONFIGURATION PARAMETERS.

4. Disconnect the device from the mains.
5. Make the electrical connection as shown in the section ELECTRICAL CONNECTION, without powering up the device.
6. To perform the configuration upload or download, connect the EVJKEY programming key. To activate real-time functions, connect the EVlinking RS-485 EVIF23TSX converter. To control the device using the EVconnect app, connect the EVlinking BLE EVIF25TBX module then synchronise it with the app. To control the device using the EPoCA monitoring system or a third-party MODBUS TCP system:
  - connect the EVlinking Wi-Fi EVIF25Twx module to the device and then to a local Wi-Fi network
  - connect the EVlinking RS-485 EVIF24TSX converter to the device then to an IoT EV3 Web gateway or EVD Web. Next connect this to a free Ethernet port of a router or an Ethernet hub connected to a local network.
7. Power up the device again.



LED	ON	OFF	FLASHING
	compressor on	compressor off	compressor protection active
	evaporator fans on	evaporator fans off	fans off evaporator fans off active
	heating active	heating not active	demisting on or door heaters on
	defrost or pre-drip active	defrost or pre-drip not active	- defrost delay active - dripping active
°F	Temperature displayed in °F	-	Setpoint being set
°C	Temperature displayed in °C	-	Setpoint being set
	clock active	clock not active	date, time and day of current week
AUX	auxiliary load 1 on	auxiliary loads 1 and 2 off	auxiliary load 2 on
%	Reserved	Reserved	Reserved
	device off	device on	device being switched on/off
	energy saving active	energy saving active	-
	overcooling or overheating active	overcooling or overheating not active	-
	alarm active	alarm not active	compressor maintenance request
HACCP	saved HACCP alarm not displayed	no HACCP alarm saved, or no saved HACCP alarm not displayed	new HACCP alarm saved
	cabinet light on	cabinet light off	cabinet light on from digital input
	connection with EVconnect app or EPoCA remote monitoring system	No connection	-



**5. USER INTERFACE AND MAIN FUNCTIONS**

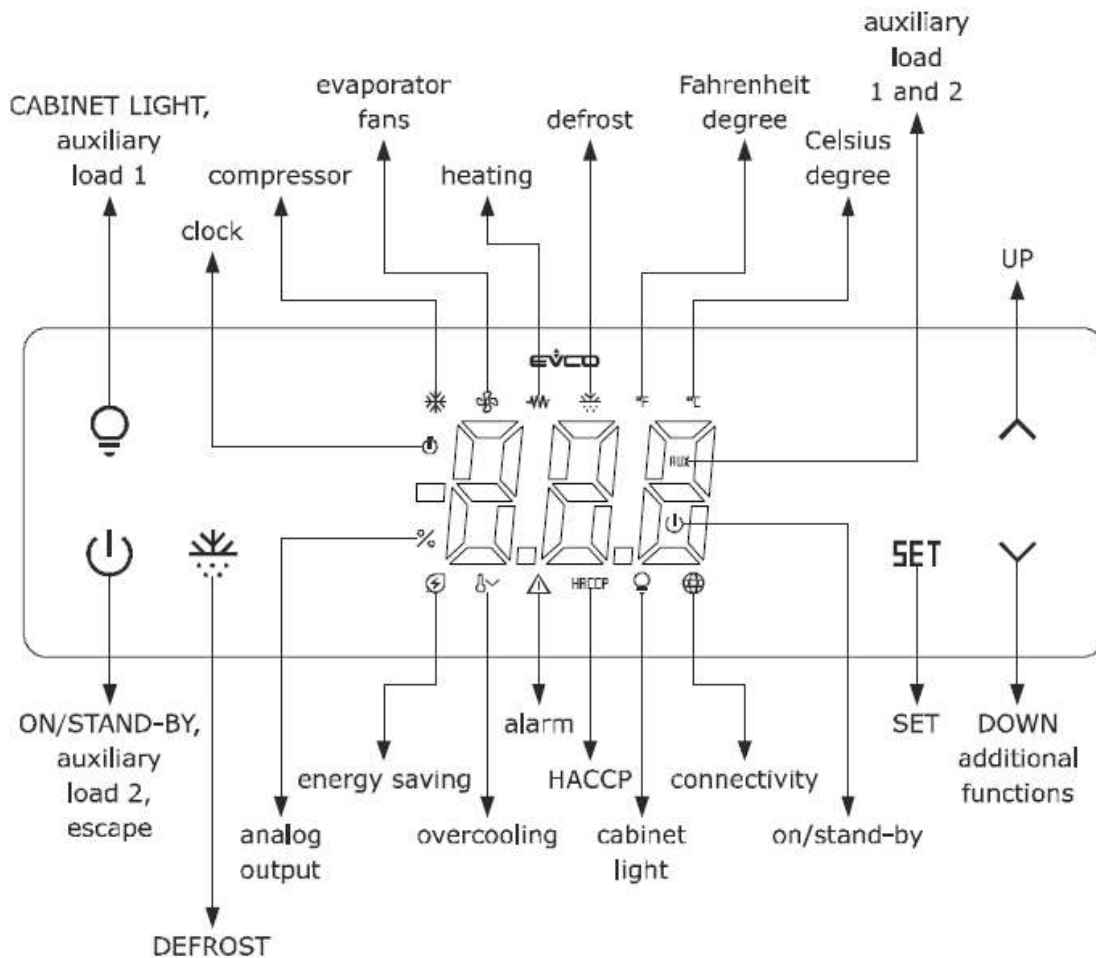

**5.1. Switching the device on/off**

1. If POF = 1 (default), touch the ON/STAND-BY key for 4 s. If the device is switched on, the display will show the P5 value (default "cabinet or product temperature"); if the display shows an alarm code, see the section ALARMS.



If Loc = 1 (default) and 30 s have elapsed without the keys being pressed, the display will show the "Loc" label and the keypad will lock automatically.

**5.2. Unlocking the keypad**

Touch a key for 1 s: the display will show the label "UnL".

**5.3. Setting the setpoint (if r3 = 0, default)**

Check that the keypad is not locked.

1.		Touch the SET key
2.		Touch the UP or DOWN key within 15 s to set the value within the limits r1 and r2 (default "-40... 50")
3.		Touch the SET key (or take no action for 15 s)

**5.4. Activating manual defrost (if r5 = 0, default)**

Check that the keypad is not locked, and that overcooling is not active.

1.  Touch the DEFROST key for 2 s.

If P3 = 1 (default), defrost is activated provided that the evaporator temperature is lower than the d2 or d2b threshold.

**5.5. Manually activating/deactivating the overcooling, overheating and energy-saving functions**

Check that the keypad is not locked.

1.  Touch the DOWN key.

FUNCTION	CONDITION	CONSEQUENCE
overcooling	r5 = 0, r8 = 1 and defrost not activated	the setpoint becomes "setpoint - r6", for the r7 time
overheating	r5 and r8 = 1	the setpoint becomes "setpoint + r6", for the r7 time
energy saving	r5 = 0 and r8 = 2 (default)	the setpoint becomes "setpoint + r4", for the HE2 time at the most

If u1c... u5c = 16, the evaporator fans will operate at this speed during the energy-saving function.

If u1c... u5c = 18, the condenser fans will operate at this speed during the energy-saving function.

**5.6. Manually switching the cabinet light on/off (if u1c-u5c = 5)**

1.  Touch the CABINET LIGHT key.

**5.7. Switching the demisting function on (if u1c-u5c = 6)**

1.  Touch the CABINET LIGHT key (for 2 s if u1c... u5c = 5).

The demisting function stays on for the duration of u6.

**5.8. Switching auxiliary load 1 on/off (if u1c... u5c = 10)**

1.  Touch the CABINET LIGHT key (for 2 s if u1c... u4c = 5)

If u1c... u5c = 6, it also switches the demisting function on.

### 5.9. Switching auxiliary load 2 on/off (if u1c... u5c = 11)

1.  Touch the ON/STAND-BY key.

### 5.10. Silencing the buzzer (if u9 = 1, default)

Touch a key.

If u1c... u5c = 11 and u4 = 1, the alarm output is deactivated.

## 6. ADDITIONAL FUNCTIONS







### 6.1. Setting the date, time and day of the week (available when the EVlinking RS-485 EVIF23TSX converter, the EVlinking BLE EVIF25TBX module or the EVlinking Wi-Fi EVIF25TWX module is connected)



**N. B.:**

- do not disconnect the device from the mains in the two minutes after setting the date, time and day of the week
- if the device communicates with the EVconnect app or the EPoCA remote monitoring system, the date, time and day of the week will automatically be set by the smartphone or tablet

Check that the keypad is not locked.

1.		Touch the DOWN key for 1 s
2.		Touch the UP or DOWN key within 15 s to select the label "rtc"
3.		Touch the SET key: the display will show the label "y" followed by the last two figures of the year
4.		Touch the UP or DOWN key within 15 s to set the year
5.	Repeat actions 3 and 4 to set the next labels	
	<b>LAB.</b>	<b>MEANING OF THE NUMBERS FOLLOWING THE LABEL</b>
	<b>n</b>	month (01-12)
	<b>d</b>	day (01-31)
	<b>h</b>	hour (00-23)
	<b>n</b>	minutes (00-59)
6.		Touch the SET key: the display will show the label for the day of the week
7.		Touch the UP or DOWN key within 15 s to set the day of the week
	<b>LAB.</b>	<b>DESCRIPTION</b>
	<b>Mon</b>	Monday
	<b>tuE</b>	Tuesday
	<b>UEd</b>	Wednesday
	<b>thu</b>	Thursday
	<b>Fri</b>	Friday



	<b>Sat</b>	Saturday
	<b>Sun</b>	Sunday
8.		Touch the SET key: the device will exit the procedure
9.		Touch the ON/STAND-BY key to exit the procedure beforehand.

**6.2. Activating the high or low humidity function (if F0 = 5)**

Check that the keypad is not locked.

1.		Touch the DOWN key for 1 s
2.		Touch the UP or DOWN key within 15 s to select the label “rH”.
3.		Touch the SET key until the display shows the label of the desired function
	<b>LAB.</b>	<b>DESCRIPTION</b>
	<b>rhL</b>	low humidity function (evaporator fans with F17 and F18 if the compressor is off, on if the compressor is on)
	<b>rhH</b>	high humidity function (evaporator fans on)
4.		Touch the ON/STAND-BY key (or take no action for 60 s) to exit the procedure

If u1c... u5c = 16, the evaporator fans will operate at this speed during low humidity function.

**6.3. Viewing/deleting HACCP alarm information**

Check that the keypad is not locked.

1.		Touch the DOWN key for 1 s
2.		Touch the UP or DOWN key within 15 s to select a label
	<b>LAB.</b>	<b>DESCRIPTION</b>
	<b>LS</b>	view HACCP alarm information
	<b>rLS</b>	delete HACCP alarm information
3.		Touch the SET key
4.		Touch the UP or DOWN key to select an alarm code (to select label “LS”) or to set “149” (to select label “rLS”)
	<b>CODE</b>	<b>DESCRIPTION</b>
	<b>AL</b>	low temperature alarm
	<b>AH</b>	high temperature alarm
	<b>id</b>	Alarma de puerta abierta (si i4 = 1)
	<b>PF</b>	power failure alarm (available when the EVlinking RS-485 EVIF23TSX converter, the EVlinking BLE EVIF25TBX module or the EVlinking Wi-Fi EVIF25TWX module is connected)
5.		Touch the SET key
6.		Touch the ON/STAND-BY key (or take no action for 60 s) to exit the procedure

Example of alarm information (e.g. a high temperature alarm).



**8.0** the critical value (cabinet or product temperature) was 8.0 °C/°F

<b>Sta</b>	(available when the EVlinking RS-485 EVIF23TSX converter, the EVlinking BLE EVIF25TBX module or the EVlinking Wi-Fi EVIF25TWX module is connected)	
<b>y24</b>	alarm signalled in 2024	
<b>n07</b>	alarm signalled in July	
<b>d03</b>	alarm signalled on 3 July 2024	
<b>h16</b>	alarm signalled at 16:00	
<b>n30</b>	alarm signalled at 16:30	
<b>dur</b>		
<b>h10</b>	alarm lasted 1 hour	
<b>n15</b>	alarm lasted 1h 15min	

**6.4. Viewing the minimum and maximum temperatures saved in the last 72 hours**

Check that the keypad is not locked.

1.		Touch the DOWN key for 1 s
2.		Touch the UP or DOWN key within 15 s to select a label
	<b>LAB.</b>	<b>DESCRIPTION</b>
	<b>Ht</b>	maximum temperature saved in the last 72 hours
	<b>Lt</b>	minimum temperature saved in the last 72 hours
3.		Touch the SET key
4.		Touch the ON/STAND-BY key (or take no action for 60 s) to exit the procedure

The device saves the rEt value (default “temperature of the cabinet or the product, not during defrost, pre-drip or dripping and with the fans off”).

When the device is switched on/off, these temperatures are deleted.

**6.5. Viewing/deleting compressor operation days**

Check that the keypad is not locked.





1.		Touch the DOWN key for 1 s
2.		Touch the UP or DOWN key within 15 s to select a label
	<b>LAB.</b>	<b>DESCRIPTION</b>
	<b>CH1</b>	view compressor operation days
	<b>CH2</b>	view compressor 2 operation days (visible if u1c... u5c = 1)
	<b>rCH</b>	delete compressor operation days
3.		Touch the SET key
4.		Touch the UP or DOWN key to set “149” (to select rCH)
5.		Touch the SET key



- 6.  Touch the ON/STAND-BY key (or take no action for 60 s) to exit the procedure



**6.6. Viewing the temperature detected by the probes**

Check that the keypad is not locked.

- 1.  Touch the DOWN key for 1 s
  - 2.  Touch the UP or DOWN key within 15 s to select a label
- | LAB.       | DESCRIPTION  |
|------------|--|
| <b>Pb1</b> | probe 1 temperature (default “cabinet temperature”, visible if PP1 ≠ 0)    |
| <b>Pb2</b> | probe 2 temperature (default “evaporator temperature”, visible if PP2 ≠ 0) |
| <b>Pb3</b> | probe 3 temperature (default “condenser temperature”, visible if PP3 ≠ 0)  |
- 3.  Touch the SET key
  - 4.  Touch the ON/STAND-BY key (or take no action for 60 s) to exit the procedure









**6.7. Starting up the EVlinking Wi-Fi module again**

Check that the keypad is not locked.

- 1.  Touch the DOWN key for 1 s
- 2.  Touch the UP or DOWN key within 15 s to select the label “run”
- 3.  Touch the SET key until the device displays the P5 value

**7. SETTINGS**

**7.1. Setting configuration parameters**









- 1.  Touch the SET key for 4 s: the display will show the label “PA”
- 2.  Touch the SET key
- 3.  Touch the UP or DOWN key within 15 s to set the PAS value (default “-19”)
- 4.  Touch the SET key (or take no action for 15 s): the display will show the label “SP”
- 5.  Touch the UP or DOWN key to select a parameter
- 6.  Touch the SET key
- 7.  Touch the UP or DOWN key within 15 s to set the value
- 8.  Touch the SET key (or take no action for 15 s)
- 9.  Touch the SET key for 4 s (or take no action for 60 s) to exit the procedure

## 7.2. Restoring factory settings



**N. B.:**

Check that the factory settings are appropriate; see the section CONFIGURATION PARAMETERS.

1.		Touch the SET key for 4 s: the display will show the label "PA"
2.		Touch the SET key
3.		Touch the UP or DOWN key within 15 s to set "149"
4.		Touch the SET key (or take no action for 15 s): the display will show the label "dEF"
5.		Touch the SET key
6.		Touch the UP or DOWN key within 15 s to set "1"
7.		Touch the SET key (or take no action for 15 s): the display will show "dEF" flashing for 4 s, after which the device will exit the procedure
8.		Disconnect the device from the power supply
9.		Touch the SET key for 2 s before action 6 to exit the procedure beforehand

## 8. CONFIGURATION PARAMETERS



Nº.	PAR.	DEF.	SETPOINT	MIN. – MAX.
1	SP	<b>0.0</b>	setpoint	r1-r2
Nº.	PAR.	DEF.	ANALOGUE INPUTS	MIN. – MAX.
2	CA1	<b>0.0</b>	Probe 1 offset	-25-25 °C/°F
3	CA2	<b>0.0</b>	Probe 2 offset	25-25 °C/°F
4	CA3	<b>0.0</b>	Probe 3 offset	25-25 °C/°F
5	P0	<b>1</b>	Type of probe	0 = PTC 1 = NTC 2 = Pt 1000
6	P1	<b>1</b>	enable decimal point °C	0 = no 1 = yes
7	P2	<b>0</b>	temperature measurement unit	0 = °C 1 = °F
8	P3	<b>1</b>	evaporator probe function	0 = disabled 1 = defrost + fans 2 = fans
9	P5	<b>0</b>	value displayed	0 = if PP1... PP3 = 5, product temperature (CPT), otherwise cabinet temperature 1 = setpoint 2 = evaporator temperature 3 = condenser temperature 4 = critical temperature 5 = incoming air temperature





				6 = outgoing air temperature 7 = evaporator 2 temperature
10	P5r	<b>0</b>	value shown on remote display	like P5
11	P7	<b>50</b>	incoming air effect to calculate product temperature (CPT)	0-100% $CPT = \{[(P7 \times (\text{incoming air})) + ((100 - P7) \times (\text{outgoing air}))] : 100\}$
12	P8	<b>5</b>	display refresh time	0-250 s: 10
13	P9	<b>5</b>	key and display brightness with keypad locked	1 = level 1 2 = level 2 3 = level 3 4 = level 4 5 = display level 4, keys level 1 6 = display level 4, keys off
14	PP1	<b>1</b>	probe 1 function	0 = disabled 1 = if PP1... PP3 = 5, incoming air temperature probe, otherwise cabinet temperature probe 2 = evaporator temperature probe 3 = condenser temperature probe 4 = critical temperature probe 5 = outgoing air temperature probe 6 = evaporator 2 temperature probe
15	PP2	<b>2</b>	probe 2 function	like PP1
16	PP3	<b>3</b>	probe 3 function	like PP1
<b>Nº.</b>	<b>PAR.</b>	<b>DEF.</b>	<b>MAIN REGULATOR</b>	<b>MIN. – MAX.</b>
17	r0	<b>2.0</b>	setpoint differential	1-15 °C/°F
18	r1	<b>-40</b>	minimum setpoint	-99 °C/°F – r2
19	r2	<b>50.0</b>	maximum setpoint	r1 – 199 °C/°F
20	r3	<b>0</b>	enable setpoint lock	0 = no 1 = yes
21	r4	<b>0.0</b>	setpoint offset in energy saving	0 – 99 °C/°F
22	r5	<b>0</b>	hot or cold mode regulation	0 = cold mode 1 = hot mode
23	r6	<b>0.0</b>	setpoint offset in overcooling/overheating	0 – 99 °C
24	r7	<b>0</b>	duration overcooling/overheating	0 – 240 minutes
25	r8	<b>2</b>	DOWN key additional function	0 = disabled 1 = overcooling/overheating 2 = energy saving
26	r12	<b>1</b>	differential position r0	0 = asymmetrical 1 = symmetrical
<b>Nº.</b>	<b>PAR.</b>	<b>DEF.</b>	<b>COMPRESSOR</b>	<b>MIN. – MAX.</b>





27	C0	3	compressor-on delay from power-on	0 – 240 minutes
28	C1	5	delay between two compressor switch-ons	0 – 240 minutes
29	C2	3	minimum compressor-off time	0 – 240 minutes
30	C3	0	minimum compressor-on time	0 – 240 s
31	C4	10	compressor-off time in cabinet probe alarm	0 – 240 minutes
32	C5	10	compressor-on time (maximum capacity) in cabinet probe alarm	0 – 240 minutes
33	C9	5	cabinet temperature consecutive time within proportional band to operate compressor at max. power	0 – 99 h 0 = disabled until cabinet temperature < setpoint
34	C10	0	compressor hours for maintenance	0 – 999 days 0 = disabled
35	C11	10	compressor 2 on delay	0 – 240 s if c14 = 0
36	C12	2	compressor hour value effect to balance hours and switch-ons (BHC)	0 – 10 BHC = {[C12 x (compressor hours)] + [C13 x (compressor switch-ons)]} if C14 = 2
37	C13	1	compressor switch-ons value effect to balance hours and switch-ons (BHC)	0 – 10 BHC = {[C12 x (compressor hours)] + [C13 x (compressor switch-ons)]} if C14 = 2
38	C14	1	constraint between compressor and compressor 2	0 = function of C11 1 = function of r0 2 = function of C12 and C13
Nº.	PAR.	DEF.	DEFROST (if r5 = 0)	MIN. – MAX.
39	d00	0	enable "b" mode parameters	0 = no 1 = yes
40	d01	1.0	setpoint threshold to activate "b" mode parameters	r1 – r2 activated if setpoint > d01
41	d0	8	automatic defrost interval	0 – 99 horas 0 = manual only if d8 = 3, maximum interval
42	d0b	6	automatic defrost interval in "b" mode	like d0
43	d1	0	type of defrost	0 = electric 1 = hot gas (do not use with regulation with 2 compressors)



				2 = compressor stopped
44	d1b	<b>2</b>	type of "b" mode defrost	like d1
45	d2	<b>2.0</b>	defrost end threshold	-99 – 99 °C/°F
46	d2b	<b>4.0</b>	"b" mode defrost end threshold	like d2
47	d3	<b>30</b>	defrost duration	0 – 99 min if P3 = 1, maximum duration
48	d3b	<b>20</b>	"b" mode defrost duration	like d3
49	d4	<b>0</b>	enable defrost at power-on	0 = no 1 = yes
50	d5	<b>0</b>	defrost delay from power-on	0 – 99 min
51	d6	<b>1</b>	value displayed when defrosting	0 = cabinet or product temperature 1 = locked display 2 = label dEF
52	d7	<b>2</b>	drip duration	0 – 15 min
53	d7b	<b>2</b>	"b" mode drip duration	like d7
54	d8	<b>0</b>	defrost interval count mode	0 = hours device on 1 = hours compressor on 2 = hours evaporator temperature < d9 3 = adaptive 4 = in real time
55	d9	<b>0.0</b>	evaporator temperature threshold for automatic defrost interval count	-99 – 99 °C/°F
56	d11	<b>0</b>	enable defrost timeout alarm	0 = no 1 = yes
57	d15	<b>0</b>	compressor-on consecutive time for hot gas defrost	-20 – 99 min if values are negative, dripping heaters on time
58	d16	<b>0</b>	pre-drip duration for hot gas defrost	0 – 99 min
59	d18	<b>40</b>	adaptive defrost interval	0 – 999 min if compressor on + evaporator temperature < d22 0 = manual only
60	d19	<b>3.0</b>	adaptive defrost threshold (relative to optimal evaporator temperature)	0 – 40 °C/°F optimal evaporator temperature - d19
61	d20	<b>180</b>	compressor-on consecutive time for defrost	0 – 999 min 0 = disabled
62	d21	<b>200</b>	compressor-on consecutive time for defrost from power-on and from overcooling	0... 999 min if (cabinet or product temperature - setpoint) > 10°C/20°F 0 = disabled

63	d22	<b>-2.0</b>	evaporator temperature threshold for adaptive defrost interval count (relative to optimal evaporator temperature)	-10... 10 °C/°F optimal evaporator temperature + d22
64	d25	<b>0</b>	enable outgoing air temperature probe for defrost in evaporator probe alarm	0 = no 1 = yes
65	d26	<b>6</b>	defrost interval in evaporator probe alarm	0 – 99 h 0 = manual only if d25 = 1
<b>Nº.</b>	<b>PAR.</b>	<b>DEF.</b>	<b>TEMPERATURE ALARMS</b>	<b>MIN. – MAX.</b>
66	A0	<b>0</b>	select value for high/low temperature alarms	0 = cabinet or product temperature 1 = evaporator temperature 2 = critical temperature
67	A1	<b>0.0</b>	low temperature alarm threshold	-99 – 99 °C/°F
68	A2	<b>0</b>	type of low temperature alarm	0 = disabled 1 = relative to setpoint (i.e. setpoint + A1) 2 = absolute (A1)
69	A4	<b>0.0</b>	high temperature alarm threshold	-99 – 99 °C/°F
70	A5	<b>0</b>	type of high temperature alarm	0 = disabled 1 = relative to setpoint (i.e. setpoint + A4) 2 = absolute (i.e. A4)
71	A6	<b>120</b>	high temperature alarm delay from power-on	0 – 240 min
72	A7	<b>15</b>	high/low temperature alarm delay	0 – 240 min
73	A8	<b>15</b>	high temperature alarm delay after defrost	0 – 240 min
74	A9	<b>15</b>	high temperature alarm delay from door closure	0 – 240 min
75	A10	<b>10</b>	duration of power failure for saving alarm	0 – 240 min 0 = disabled
76	A11	<b>2.0</b>	high/low temperature alarm threshold differential (A1 and A4)	1 – 15 °C/°F
77	A12	<b>1</b>	enable power failure alarm signal	0 = no 1 = yes (label PF, if EVlinking RS-485 EVIF23TSX, EVlinking BLE EEVIF25TBX or EVlinking Wi-Fi EVIF25TWX is connected)
78	A13	<b>80</b>	high condensation signal threshold	0 – 199 °C/°F Differential = 2°C / 4°F



79	A14	<b>90</b>	high condensation alarm threshold	0 – 199 °C/°F
80	A15	<b>10</b>	high condensation alarm delay	0 – 15 min
81	A16	<b>0</b>	enable viewing of high/low temperature alarms on remote display	0 = no 1 = yes
<hr/>				
<b>Nº.</b>	<b>PAR.</b>	<b>DEF.</b>	<b>FANS</b>	<b>MIN. – MAX.</b>
82	F0	<b>1</b>	evaporator fan mode in normal operation	0 = off    1 = on 2 = on if compressor on 3 = thermostat controlled (with cabinet or product temperature + F1) 4 = thermostat controlled (with cabinet or product temperature + F1) if compressor on 5 = function of F6 6 = thermostat controlled (with evaporator temperature + F1) 7 = thermostat controlled (with evaporator temperature + F1) if compressor on
83	F0b	<b>1</b>	evaporator fan mode in normal “b” mode operation	like F0
84	F1	<b>-4.0</b>	evaporator fans regulation threshold	-99 – 99 °C/°F
85	F2	<b>0</b>	evaporator fan mode in defrost and drip mode	0 = off    1 = on 2 = function of F0
86	F2b	<b>0</b>	evaporator fan mode in “b” mode defrost and drip	like F2
87	F3	<b>2</b>	maximum time evaporator fans off	0 – 15 min
88	F3b	<b>2</b>	maximum time evaporator fans off in “b” mode	0 – 15 min
89	F4	<b>30</b>	time evaporator fans off in energy saving	0 – 240 s x 10 if F0 ≠ 5
90	F5	<b>30</b>	time evaporator fans on in energy saving	0 – 240 s x 10 if F0 ≠ 5
91	F6	<b>0</b>	low or high humidity function	0 = for low humidity (with F17 and F18 if compressor off, on if compressor on) 1 = for high humidity (fans on)
92	F7	<b>5.0</b>	evaporator fans on threshold from dripping (relative to setpoint)	-99 – 99 °C/°F Setpoint + F7
93	F8	<b>2.0</b>	evaporator fans regulation threshold differential (F1)	1 – 15 °C/°F
94	F9	<b>10</b>	evaporator fans off delay from compressor off	0 – 240 s if F0 = 2 o 5











95	F10	1	condenser fan mode in normal operation	0 = thermostat controlled (with condenser temperature + F11) 1 = thermostat controlled (with condenser temperature + F11) if compressor off, on if compressor on 2 = thermostat controlled (with condenser temperature + F11) if compressor off, on if compressor on, off in defrost, pre-drip and dripping
96	F11	15.0	condenser fans on threshold	0 – 99 °C/°F Differential = 2°C / 4°F
97	F12	30	condenser fans off delay from compressor off	0 – 240 s if PP1 – PP3 ≠ 3
98	F13	2	condenser fans on threshold differential (F11)	1 – 25 °C/°F
99	F14	10	100 % start-up time for 0-10 V condenser fans	0 – 240 s
100	F15	100	maximum percentage 0-10 V condenser fans in energy saving	0 – 100 %
101	F17	60	time evaporator fans off in low humidity	0 – 240 s
102	F18	10	time evaporator fans on in low humidity	0 – 240 s
103	F19	0	reversible condenser fans on interval	0 – 240 h
104	F20	0	reversible condenser fans on time	0 – 240 min
Nº.	PAR.	DEF.	DIGITAL INPUTS	MIN. – MAX.
105	i0	5	door switch input function	0 = disabled 1 = compressor + evaporator fans off 2 = evaporator fans off 3 = cabinet light on 4 = compressor + evaporator fans off, cabinet light on 5 = evaporator fans off, cabinet light on
106	i1	0	door switch input activation	0 = with contact closed 1 = with contact open
107	i2	30	door open alarm delay	-1 – 120 min -1 = disabled
108	i3	15	maximum compressor and evaporator fan off time with door open	-1 – 120 min -1 = until closed
109	i4	0	enable door open alarm saving	0 = no      1 = yes if i2 ≠ -1 and after i2



110	i10	0	door closed consecutive time for energy saving	0 – 999 min after cabinet or product temperature < SP 0 = disabled
111	i13	180	number of door openings for defrost	0 – 240 0 = disabled
112	i14	32	door open consecutive time for defrost	0 – 240 min 0 = disabled
Nº.	PAR.	DEF.	DIGITAL OUTPUTS	MIN. – MAX.
113	u1c	0	K1 relay configuration	0 = compressor 1 = compressor 2 2 = evaporator fans 3 = condenser fans 4 = defrost 5 = cabinet light 6 = demisting 7 = door heaters 8 = heaters for neutral zone 9 = dripping heaters 10= auxiliary load 1 11= auxiliary load 2 12= alarm 13= on/stand-by 14= evaporator fans 2 15= defrost 2 16= speed 2 evaporator fans 17= reversible condenser fans 18= speed 2 condenser fans
114	u2c	12	K2 relay configuration	like u1c
115	u3c	4	K3 relay configuration <b>not available in EVY232LN3EFXXX1</b>	like u1c
116	u4c	5	12... 24 Vdc output configuration	like u1c
117	u5c	2	12... 24 Vdc output configuration	like u1c
118	u2	0	enable cabinet light and auxiliary load 1 and 2 in stand-by	0 = no      1 = yes in manual mode
119	u3	0	alarm output activation	0 = with alarm not active 1 = with alarm active
120	u4	1	enable deactivation alarm output with silencing buzzer	0 = no 1 = yes
121	u5	-1.0	door heaters on threshold	-99 – 99 °C/°F
122	u5d	2.0	door heaters on threshold differential (u5)	1– 25 °C/°F
123	u6	5	duration demisting on	1 – 120 min 1 = manual switch on/off



	124	u7	<b>-5.0</b>	neutral zone for heating threshold (relative to setpoint)	-99 – 99 °C/°F Differential = 2°C / 4°F Setpoint + u7
	125	u9	<b>1</b>	enable alarm buzzer	0 = no 1 = yes
	Nº.	PAR.	DEF.	CLOCK	MIN. – MAX.
	126	Hr0	<b>0</b>	enable clock	0 = no 1 = yes
	Nº.	PAR.	DEF.	ENERGY SAVING (if r5 = 0)	MIN. – MAX.
	127	HE2	<b>0</b>	maximum duration energy saving	1 – 999 min 0 = until door opened
	Nº.	PAR.	DEF.	ENERGY SAVING IN REAL TIME (if r5 = 0)	MIN. – MAX.
	128	H01	<b>0</b>	energy saving time	0 – 23 h
	129	H02	<b>0</b>	maximum duration energy saving	0 – 24 h
	Nº.	PAR.	DEF.	SWITCH ON/OFF IN REAL TIME	MIN. – MAX.
	130	Hon	<b>h-</b>	time device switch-on	0 h h = disabled
	131	HoF	<b>h-</b>	time device switch-off	0 h h = disabled
	132	Hc1	<b>h-</b>	1st time reversible condenser fans on	0... h h = disabled for F20
	133	Hc2	<b>h-</b>	2nd time reversible condenser fans on	like Hc1
	Nº.	PAR.	DEF.	REAL-TIME DEFROST	MIN. – MAX.
	134	Hd1	<b>h-</b>	1st daily defrost time	0 h h = disabled
	135	Hd2	<b>h-</b>	2nd daily defrost time	like Hd1
	136	Hd3	<b>h-</b>	3rd daily defrost time	like Hd1
	137	Hd4	<b>h-</b>	4th daily defrost time	like Hd1
	138	Hd5	<b>h-</b>	5th daily defrost time	like Hd1
	139	Hd6	<b>h-</b>	6th daily defrost time	like Hd1
	Nº.	PAR.	DEF.	SECURITY	MIN. – MAX.
	140	POF	<b>1</b>	enable ON/STAND-BY key	0 = no 1 = yes
	141	Loc	<b>1</b>	enable keypad lock	0 = no 1 = yes (after 30 s)
	142	Sen	<b>80</b>	keypad sensitivity	40 – 120 40 = very sensitive
	143	PAS	<b>-19</b>	password to access settings from keypad	-99 – 999
	144	PA1	<b>426</b>	level 1 password to access settings from EVconnect and EPoCA	99 – 999



	145	PA2	<b>824</b>	level 2 password to access settings from EVconnect and EPoCA	99 – 999
	<b>Nº.</b>	<b>PAR.</b>	<b>DEF.</b>	<b>DATA-LOGGING</b>	<b>MIN. – MAX.</b>
	146	rE0	<b>15</b>	EVlinking data logger sampling interval	0 – 240 min
	147	rE1	<b>1</b>	select temperature for EVlinking data logger	0 = none      1 = cabinet 2 = evaporator 3 = condenser 4 = critical 5 = outgoing air 6 = evaporator 2 7 = product 8 = cabinet + evaporator + condenser 5 = all
	148	rEt	<b>0</b>	select temperature for data logger device in last 72 hours	0 = cabinet or product (not during defrost, predripping, dripping and fan stop) 1 = cabinet or product (also during defrost, predripping, dripping and fan stop) 2 = critical (not during defrost, pre-dripping, dripping and fan stop) 3 = critical (also during defrost, pre-dripping, dripping and fan stop) 4 = cabinet or product (only during defrost, predripping, dripping and fan stop)
	<b>Nº.</b>	<b>PAR.</b>	<b>DEF.</b>	<b>MODBUS</b>	<b>MIN. – MAX.</b>
	149	LA	<b>247</b>	MODBUS address	1 - 257
	150	Lb	<b>3</b>	MODBUS baud rate	0 = 2,400 baud 1 = 4,800 baud 2 = 9,600 baud 3 = 19,200 baud
	151	LP	<b>2</b>	MODBUS parity	0 = none      1 = odd 2 = even
	<b>Nº.</b>	<b>PAR.</b>	<b>DEF.</b>	<b>MODBUS USE</b>	<b>MIN. – MAX.</b>
	152	bLE	<b>1</b>	type of use of TTL MODBUS port	0 = for EVIF23TSX or third-party MODBUS TCP system (via EVIF24TSX) 1 = for EVconnect (via EVIF25TBX) or EpoCA (via EVIF25TWX) 2... 99 = for EPoCA (via EVIF24TSX and IoT EV3 Web gateway or EVD Web)

## 9. ALARMS

CODE	DESCRIPTION	RESET	TO CORRECT
Pr1	probe 1 alarm	Automatic	- check P0
Pr2	probe 2 alarm	Automatic	- check the integrity of the probe
Pr3	probe 3 alarm	Automatic	- check electrical connection
rtc	clock alarm	Manual	set date, time and day of the week
AL	low temperature alarm	Automatic	check A0, A1 and A2
AH	high temperature alarm	Automatic	check A0, A4 and A5
id	door open alarm	Automatic	check i0 and i1
PF	power failure alarm	Manual	- touch a key - check electrical connection
COH	high condensation signal	Automatic	check A13
CSd	high condensation alarm	Manual	- switch the device off and on - check A14
dFd	defrost timeout alarm	Manual	- touch a key - check d2, d2b, d3, d3b and d11

## 10. TECHNICAL SPECIFICATIONS

Purpose of the control device:	function controller
Construction of the controller device:	build-in electronic device
Case:	black, self-extinguishing
Category of heat and fire resistance:	D
Measurements:	193.0 x 59.0 x 73.0 mm (7 5/8 x 2 5/16 x 2 7/8 in)
Mounting methods for the control device:	front installation on a plastic or metal panel (with elastic holding flaps)
Degree of protection provided by the casing:	IP65 (front), provided that the device is installed on a metal panel 0.8 mm (1/32 in) thick
Connection method:	plug-in screw terminal blocks for wires up to 1.5 mm <sup>2</sup> (analogue inputs, digital inputs and analogue outputs) and wires up to 2.5 mm <sup>2</sup> (power supply, digital outputs and 12... 24 Vdc outputs)
Pico-Blade connector	
Maximum permitted length for connection cables:	
power supply: 10 m	analogue inputs: 10 m (32.8 ft)
digital inputs: 10 m (32.8 ft)	analogue outputs: 3 m (9.84 ft)
digital outputs: 10 m (32.8 ft)	12... 24 Vdc outputs: 10 m (9.84 ft)
Operating temperature:	from -5 to 60 °C (from 23 to 140 °F)
Storage temperature:	from -25 to 70 °C (from -13 to 158 °F)
Operating humidity:	relative humidity without condensate from 10 to 90 %
Pollution status of the control device:	2
Compliance:	
RoHS 2011/65/EC	WEEE 2012/19/EU

REACH (EC) Regulation nº 1907/2006		LVD 2014/35/EU
Power supply:		12... 24 Vdc (+10 % -15 %), max. 3 W
Earthing methods for the control device:		none
Rated impulse withstand voltage:		4 kV
Overvoltage category:		III
Software class and structure:		A
Analogue inputs:		3 for configurable PTC, NTC or Pt 1000 probes
PTC probes:	Type of sensor:	KTY 81-121 (990 $\Omega$ @ 25 °C, 77 °F)
	Measurement field:	from -50 to 150 °C (from -58 to 302 °F)
	Resolution:	0,1 °C (1 °F)
NTC probes:	Type of sensor:	B3435 (10 k $\Omega$ @ 25 °C, 77 °F)
	Measurement field:	from -40 to 105 °C (from -40 to 221 °F)
	Resolution:	0,1 °C (1 °F)
Pt 1000 probes:	Type of sensor:	1 k $\Omega$ @ 0 °C, 32 °F
	Measurement field:	from -99 to 199 °C (from -146 to 390 °F)
	Resolution:	0,1 °C (1 °F)
Digital inputs:		1 voltage-free (door switch)
Voltage-free:	Type of contact:	3,3 Vdc, 1 mA
	Power supply:	none
	Protection:	none
Digital outputs:		according to the model, 2 or 3 with sealed electro-mechanical relays in compliance with the EN 60079-15 standard
K1 relay:		SPST, 30 res. A @ 250 Vac
K2 relay:		SPDT, 8 res. A @ 250 Vac
K3 relay:		SPDT, 16 res. A @ 250 Vac (not available in EVY232LN3EFXXX1)
The device guarantees reinforced insulation between the digital outputs (electro-mechanical relays) and the SELV (Safety Extra Low Voltage) circuits, as well as between the digital output groups		
12... 24 Vdc outputs:		two, 2.5 A max each
If the device is powered at 12 Vdc, the outputs will supply 12 Vdc 2.5 A max each; if the device is powered at 24 Vdc, the outputs will supply 24 Vdc 2.5 A max each		
Type 1 or Type 2 actions:		Type 1
Additional features of Type 1 or Type 2 actions:		C
Displays:		custom display with 3 digits and function icons
Alarm buzzer:		built-in
Communication ports:		1 x TTL MODBUS slave port for the EVconnect app or EPoCA remote monitoring system

**N. B.:**

The device must be disposed of according to local regulations governing the collection of electrical and electronic equipment.

EVY232LN3EFXXX1/EVY233LN3EFXXX1



This document and the solutions contained therein are the intellectual property of EVCO and thus protected by the Italian Intellectual Property Rights Code (CPI). EVCO forbids the reproduction and distribution, even in part, of the contents, unless express authorisation is obtained directly from EVCO. The customer (manufacturer, installer or end user) assumes all responsibility for the configuration of the device. EVCO accepts no liability for any possible errors in this document and reserves the right to make any changes at any time without prejudice to the essential functional and safety features of the equipment.