

# ICE CREAM

DISPLAY CASES

CORAL · ARIES · IBIZA SERIES



 Infrico





# Corral

## DISPLAY CASES

### FEATURES

- Constructed with a white compac quartz worktop, straight heated front glass, tilting front glass.
- It has a display surface to hold 5L trays [360x165x150] in a distribution of 14 to 20 trays.
- Greater precision in the temperature and humidity control system. Easier adjustment of the desired temperature range.
- Incorporation of LED lighting, reducing energy consumption by 80% to 90%.
- Ventilated condensation system.
- Final defrost temperature control.
- Hot gas defrosting.

# CORAL DISPLAY CASE FOR ICE CREAM STRAIGHT GLASS

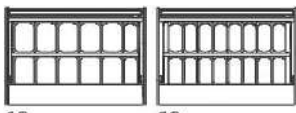
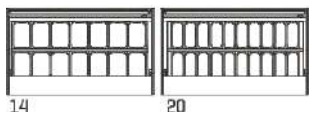
MODEL	VCB 12 UH	VCB 15 UH	VCB 18 UH
PRICE			
MEASUREMENTS WITHOUT SIDES	1250 x 1052 x 1200 mm	1562 x 1052 x 1200 mm	1875 x 1052 x 1200 mm
TEMPERATURE	-15°C/-18°C		
CLIMATIC CLASS	7 / 35°C		
VOLTAGE FREQUENCY	230V/1ph/50Hz		
CONTROLLER	Digital		
MATERIAL	Plasticized steel · Exposure plane: Inox Aisi 304		
ISOLATION	40kg/m <sup>3</sup> / Free CFC's / Zero ODP-GWP		
CAPACITY	182	228	274
SURFACE EXHIBITION	0,96	1,20	1,49
COMPRESSOR	1 1/4	1 1/4 + 1	1 1/4 + 1
TRAYS	8 / 14	10 / 16	14 / 20
SIDES [2]	20+20		
COOLING SYSTEM	Ventilated		
DEFROST	Hot gas		
EVAPORATION	Ventilated		
POWER	1250	1570	1640
CONSUMPTION	19,7	28,9	30,8
REFRIGERANT	<b>R290</b>		
	230v/1ph/60 Hz		
OPTIONAL	<p>TRAYS COMBINATION [501X36] x 8uds. [501X32] x 14uds.</p>  <p>8      14</p> <p>REAR SLIDING DOORS PUEVCB12CT</p>	<p>TRAYS COMBINATION [501X36] x 10uds. [501X32] x 16uds.</p>  <p>10      16</p> <p>REAR SLIDING DOORS PUEVCB15CT</p>	<p>TRAYS COMBINATION [501X36] x 14uds. [501X32] x 20uds.</p>  <p>14      20</p> <p>REAR SLIDING DOORS PUEVCB18CT</p>

VCB15UH

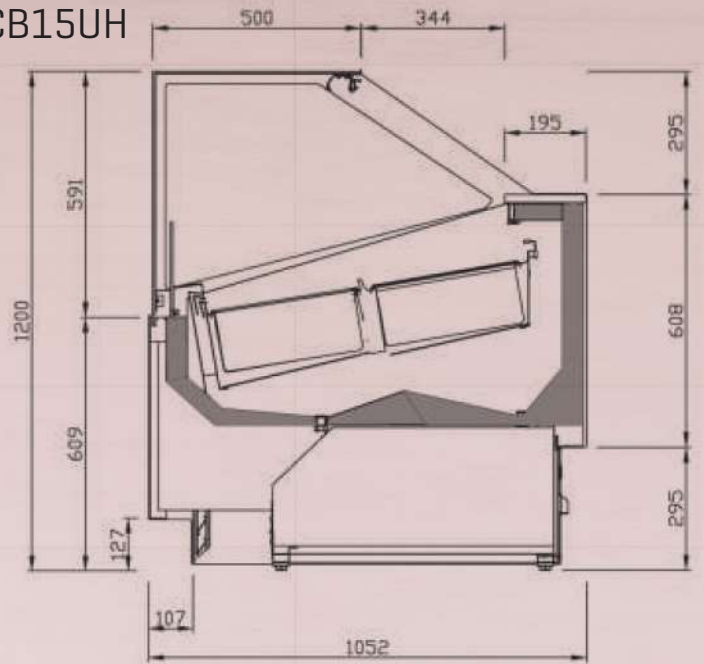

# VCB18UH

STRAIGHT GLASS

Optional trays combination



# Avi



With lift-up glass

## FEATURES

- Constructed with a worktop in white compac quartz, curved, heated, hinged front glass.
- It has a display surface to hold 5L trays (360x165x150) in a distribution of 14 to 20 trays.
- Greater precision in the temperature and humidity control system. Easier adjustment of the temperature range we wish to achieve.
- Incorporation of LED lighting, reducing energy consumption by between 80% and 90%.
- Ventilated condensation system.
- Final defrost temperature control.
- Hot gas defrosting.





# DISPLAY CASES

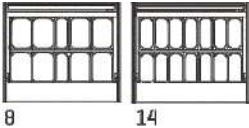
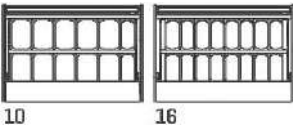
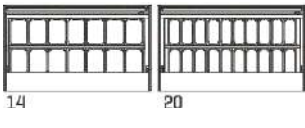

# ARIES DISPLAY CASE FOR ICE CREAM CURVED GLASS

MODEL	VAR 12 H	VAR 15 H	VAR 18 H
PRICE			
MEASUREMENTS WITHOUT SIDES	1250 x 1145 x 1320 mm	1562 x 1145 x 1320 mm	1875 x 1145 x 1320 mm
TEMPERATURE	-15°C/-18°C		
CLIMATIC CLASS	7 / 35°C		
VOLTAGE FREQUENCY	230V/1ph/50Hz		
CONTROLLER	Digital		
MATERIAL	Plasticized steel · Exposure plane: Inox Aisi 304		
ISOLATION	40kg/m <sup>3</sup> / Free CFC's / Zero ODP-GWP		
CAPACITY	182	228	274
SURFACE EXHIBITION	0,96	1,26	1,44
COMPRESSOR	1 1/4	1 1/4 + 1	1 1/4 + 1
TRAYS	8 / 14	10 / 16	14 / 20
SIDES [2]	40+40		
COOLING SYSTEM	Ventilated		
DEFROST	Hot gas		
EVAPORATION	Ventilated		
POWER	1020	1536	1640
CONSUMPTION	19,7	28,9	30,8
REFRIGERANT	<b>R290</b>		
	230v/1ph/60 Hz		
OPTIONAL	<p>TRAYS COMBINATION [501X36] x 8uds. [501X32] x 14uds.</p>  <p>8      14</p>	<p>TRAYS COMBINATION [501X36] x 10uds. [501X32] x 16uds.</p>  <p>10      16</p>	<p>TRAYS COMBINATION [501X36] x 14uds. [501X32] x 20uds.</p>  <p>14      20</p>

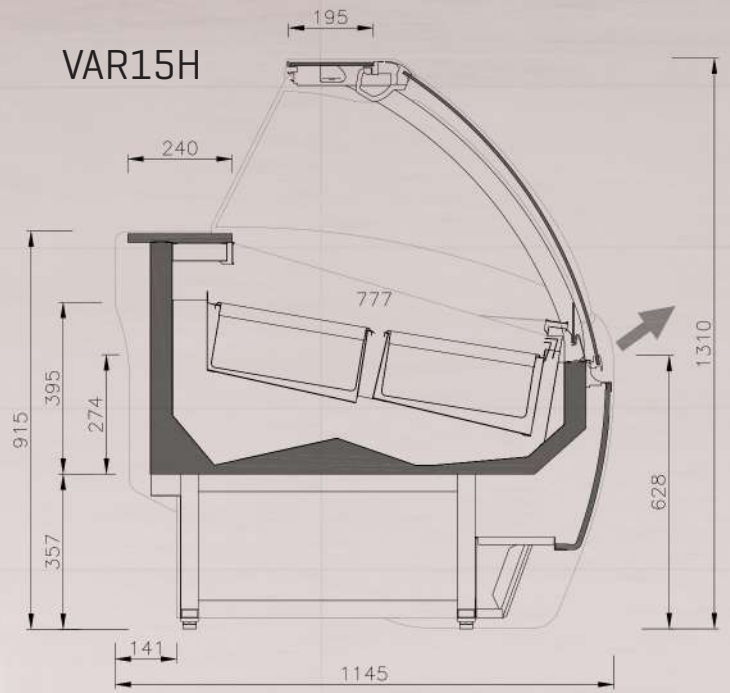

# VAR15H

CURVED GLASS





# Iceiza

## DISPLAY CASES

### FEATURES

- Constructed with a worktop in white compac quartz, flat tempered heated front glass, hinged.
- It has a display top to accommodate a distribution of 7 to 13 trays on two levels.
- Greater precision in the temperature and humidity control system. Easier adjustment of the temperature range we wish to achieve.
- Incorporation of LED Visera lighting, reducing energy consumption by between 80% and 90%.
- Ventilated condensation system.
- 8°C final defrost temperature control.



 Infrico

# IBIZA DISPLAY CASE FOR ICE CREAM STATIC

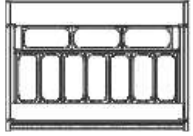
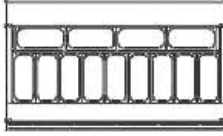
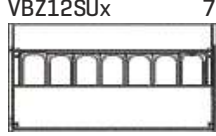
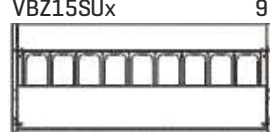
MODEL	VBZ 12U	VBZ 15U	VBZ 12 SU	VBZ 15 SU
PRICE				
MEASUREMENTS WITHOUT SIDES	1310 x 920 x 1350 mm	1622 x 920 x 1350 mm	1310 x 670 x 1350 mm	1622 x 670 x 1350 mm
TEMPERATURE	-15°C/-18°C			
CLIMATIC CLASS	7 / 35°C			
VOLTAGE FREQUENCY	230V/1ph/50Hz			
CONTROLLER	Digital			
MATERIAL	Plasticized steel · Exposure plane: Inox Aisi 304			
ISOLATION	40kg/m 3/ Free CFC's / Zero ODP-GWP			
CAPACITY	289	361	210	263
SURFACE EXHIBITION	0,94	1,41	0,50	0,63
COMPRESSOR	1		3/4	
TRAYS	10+10	13+13	7+7	9+9
SIDES [2]	30 +30			
COOLING SYSTEM	Static			
DEFROST	Hot gas			
EVAPORATION	Ventilated			
POWER	480	484	432	436
CONSUMPTION	11,5	13,6	9,9	11,5
REFRIGERANT	<b>R290</b>			
OPTIONAL	Standard castors			
	<p>TRAYS COMBINATION</p> <p><b>VBZ12</b> [501X32] x 10 uds.</p> <p><b>VBZ15</b> [501X32] x 13 uds.</p> <div style="display: flex; justify-content: space-around; align-items: flex-end;"> <div style="text-align: center;"> <p>VBZ12U x10</p>  </div> <div style="text-align: center;"> <p>VBZ15U x13</p>  </div> </div>		<p>TRAYS COMBINATION</p> <p><b>VBZ12S</b> [501X32] x 7 uds.</p> <p><b>VBZ15S</b> [501X32] x 9 uds.</p> <div style="display: flex; justify-content: space-around; align-items: flex-end;"> <div style="text-align: center;"> <p>VBZ12SUx 7</p>  </div> <div style="text-align: center;"> <p>VBZ15SUx 9</p>  </div> </div>	

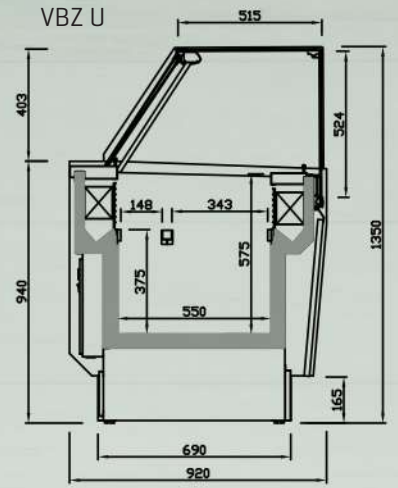
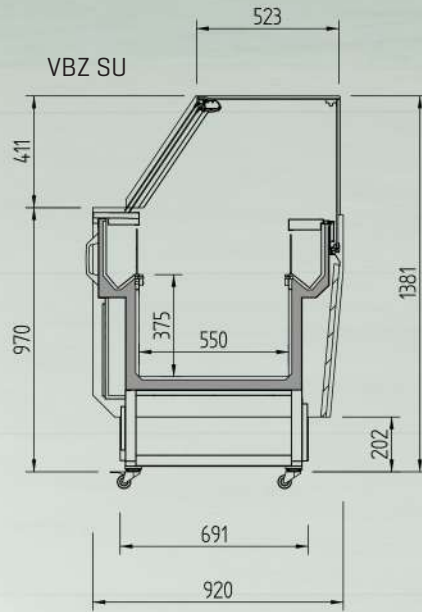

# VBZ 15SU



**STANDARD EXTERIOR COLOURS** Please ask for colours outside the colour chart



Ral 9016



Ral 1001



Ral 3003



Ral 3020



Ral 5015



Design 1107060



Ral 8017



Ral 9016

COLOURS APPLY TO CORAL, ARIES, IBIZA SERIES



Ral 1018



Ral 2003



Ral 4007



Design 3504035



Ral 6002



Design 2108025



Ral 7016



Ral 9017

# ICE CREAM DISPLAY CASES

## FOR ALL TASTES AND FLAVOURS

Infrico's ice cream display cases are designed to offer a stylish and attractive presentation of your products. With a modern design and excellent visibility, they combine innovation and functionality in a sophisticated design to ensure that ice cream is kept at the perfect temperature to retain its texture and flavour.

These display cases offer optimal visibility and LED lighting that enhances the colours and presentation of the ice cream. Thanks to their efficient refrigeration system and robust construction, Infrico's ice cream display cases ensure reliable and long-lasting performance, ideal for any establishment looking to excel in ice cream sales.

Available in various sizes and configurations, these display cases are the perfect choice for displaying your ice cream in the coolest and most attractive way.

GRUPO   
**Infrico**®

Ctra. de Aguilar a A-318 por Moriles, km 15,5 - A-3132

CP 14900 LUCENA, Córdoba - España

Tel: 0034 957 51 30 68

[info@infrico.com](mailto:info@infrico.com)



[www.infrico.com](http://www.infrico.com)

