



## VIVID CONTOUR: SILICONE - 12V

Indoor & Outdoor Rated Linear Flex Profile - Static Whites & Colors



### PROFILE CAPABILITIES

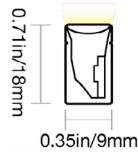

LIGHT SURFACE

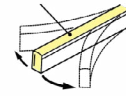

SIDE BENDING

MIN BENDING DIAMETER



3.54IN (90MM)

### CERTIFICATIONS & FEATURES\*



### TEMPERATURES

**AMBIENT OPERATING TEMPERATURE:**  
-40°F to 149°F (-40°C to 65°C)

**AMBIENT INSTALLATION TEMPERATURE:**  
-40°F to 140°F (-40°C to 60°C)

**FIXTURE STORAGE TEMPERATURE:**  
-40°F to 140°F (-40°C to 60°C)

**MAX MOUNTING SURFACE TEMPERATURE:**  
185°F (85°C)

**HUMIDITY (NON-CONDENSING):**  
0-95%

**THERMAL MANAGEMENT:**  
Free Air Convection

### FIXTURE ORDER CODE

E		A				B		
INPUT CONNECTORS	SERIES	MATERIAL	PROFILE	BENDING	JACKET/BASE + LENS COLOR	LED FUNCTION	LED COLOR	CHIP + CRI
See Page 5 to to select input connector	V = Vivid	1 = Silicone	B = Contour	1 = Side	W = White + Diffused	1 = Static	A = Amber B = Blue C = Green E = Red H = 2200K J = 2700K L = 3000K M = 3500K N = 4000K Q = 5700K	1 = Epistar SMD LED Chip Colors 2 = Epistar SMD LED Chip + CRI80 Whites
C		D	E		F		G	
POWER	VOLTAGE + CIRCUIT TYPE	ORDER UNIT LENGTH	OUTPUT CONNECTOR		MOUNTING PROFILE		MOUNTING ACCESSORIES	
B = 1.37w/ft (4.5w/m)	2V = 12V DC CV	B = 1.64in (41.7mm)	See Page 5 to select output connector		See Page 12 to select mounting profiles		See Page 15 to select accessory	
POWER SUPPLIES & CONTROLS:		By Others By GLLS						

\*Maximum IP and IK ratings achievable with appropriate accessories, and cable diameter: Silicone Static = 0.26in (6.5mm).

# VIVID CONTOUR: SILICONE - 12V

Indoor & Outdoor Rated Linear Flex Profile - Static Whites & Colors



## A

### MECHANICAL

#### ASSEMBLY

Fixtures are carefully assembled using high-quality components to ensure durability and performance. Each unit is built to meet strict specifications, with attention to electrical safety, thermal management, and optical alignment.

#### OVERALL & CUTTING LENGTHS

Fixtures feature defined overall lengths and specific cutting increments for easy customization. Cutting must be done at marked points to maintain proper function and consistent light output.

#### JACKET COLOR

The white jackets with diffused lens covers provide a clean, uniform appearance while softening light output for reduced glare. It enhances visual comfort and delivers smooth, even illumination ideal for architectural and display applications.

#### BENDING RADIUS

Do not bend smaller than allowed minimum bend diameter, or may cause damage to the light & void warranty.

### TESTING

#### OPTICAL TESTING

TEST	RESULTS
Spectrum Analysis	IES LM 79 (Lumen, CCT, CRI, XY, SDCM, Wavelength)
Photometric Distribution	IES LM 79
Lumen Maintenance & Lifetime	IES LM 84 & IES TM28

#### ENVIRONMENTAL TESTING

TEST	RESULTS
Salt Water Immersion	IEC60598-1, Saltinity 4%
Salt Spray Test	IEC60068-2-11
Outdoor Exposure	Manufacturer-defined
Flame Resistance	UL94
UV Exposure	ASTMG 154, ISO 4892-3, UVA @ 340nm & 55
IPX8	EN 60598-1: 2015+A1:2018 Clause 9.2.2 & 9.2.8
Temperature Shock(Silicone)	Manufacturer-defined, -40°C - 60°C (typical temperature range)
Constant Temperature	Manufacturer-defined
12mm Needle Flame Test (Silicone)	IEC60695-11-5
650 Glow-wire Test (Silicone)	IEC60695-2-10

### OPERATION

#### LIGHT ENGINE

Static Pulse Width Modulation (PWM) light engines deliver stable, flicker-free light at a fixed brightness. They offer consistent color and reliable performance for long-term applications.

#### ELECTRICAL

Designed to meet UL, CE, and RoHS standards, they feature overload, overvoltage, and short-circuit protection, along with low EMI and efficient thermal management for safe, reliable operation.

#### DIMMING

Dimming of 24V PWM fixtures is achieved via the driver or decoder used in the system. Depending on the selected driver/decoder, control options can include 0-10V, DMX, or DALI, enabling smooth, flicker-free dimming while maintaining consistent color and performance. Note: DMX and DALI are supported at the system level, not natively by the fixture.

### GENERAL

#### WARRANTY

Limited 5-Year Warranty against defects in materials and manufacturing. Coverage applies to properly installed and maintained products. Damage from misuse or improper installation is not covered. G.L.L.S. may repair, replace, or issue credit for eligible claims.

#### LUMEN MAINTENANCE

G.L.L.S. static lighting fixtures are tested to IES LM-84 and projected with IES TM-28 to ensure consistent lumen maintenance. Fixtures are designed to retain at least 70% of their initial brightness (L70) over a 10-year lifespan when properly installed and operated.

#### CERTIFICATION

Tested to UL2108 Class 2 by Underwriters Laboratory for use in the USA and Canada. Exceeds ANSI C78.377A, CE, and RoHS standards. Must be used under Class 2 ratings to maintain certification.

UL Certificate #: E347880

Report Reference #: E347880-20130503

#### TEMPERATURE TESTING

TEST	RESULTS
Normal Temperature Test	UL1598 & UL2388 & IEC60598-1 & IEC60598-2-21
Abnormal Operation Test	UL1598 & UL2388 & IEC60598-1 & IEC60598-2-21

#### DURABILITY TESTING

TEST	RESULTS
Bending Test	Manufacturer-defined, 500 cycles
Tensile Test	Manufacturer-defined, > The weight of light in max.
Twist Test	Manufacturer-defined, >200 cycles
Ball Impact	UL1598 & UL2388 & IEC60598-1 & IEC60598-2-21
IK	IEC62262



# VIVID CONTOUR: SILICONE - 12V

Indoor & Outdoor Rated Linear Flex Profile - Static Whites & Colors



## B

### LED COLORS

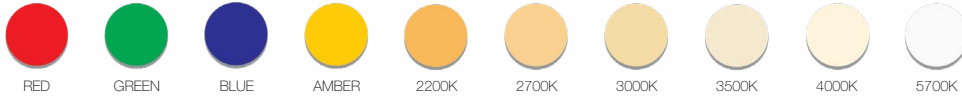

### FIXTURE SPECIFICATIONS & OPTICAL PARAMETERS

COLOR	LED COUNT	1 CONNECTOR FULL/DYNAMIC*	2 CONNECTORS FULL/DYNAMIC*	UL CLASS 2 MAX RUN**	FIXTURE COLOR TOLERANCE***	WAVELENGTH/ CCT	LED CRI	LED COLOR TOLERANCE	LUMEN COUNT	LEGACY ORDER CODE
RED	22 LEDs/ft (72 LEDs/m)	49.2ft (15m) / N/A	98.4ft (30m) / N/A	44ft (13m)	N/A	618-624nm	N/A	3nm	20lm/ft (65lm/m)	SF09A1012WERED12DV
GREEN	22 LEDs/ft (72 LEDs/m)	49.2ft (15m) / N/A	98.4ft (30m) / N/A	44ft (13m)	N/A	522-530nm	N/A	3nm	40lm/ft (130lm/m)	SF09A1012WEGRE12DV
BLUE	22 LEDs/ft (72 LEDs/m)	49.2ft (15m) / N/A	98.4ft (30m) / N/A	44ft (13m)	N/A	468-474nm	N/A	3nm	8lm/ft (25lm/m)	SF09A1012WEBLU12DV
AMBER	22 LEDs/ft (72 LEDs/m)	49.2ft (15m) / N/A	98.4ft (30m) / N/A	44ft (13m)	N/A	588-594nm	N/A	3nm	20lm/ft (65lm/m)	SF09A1012WEAMB12DV
2200K	22 LEDs/ft (72 LEDs/m)	49.2ft (15m) / N/A	98.4ft (30m) / N/A	44ft (13m)	3 SDCM	2238 ± 66K	82-87	2.3SDCM	34lm/ft (110lm/m)	SF09A1012WE22K12DV
2700K	22 LEDs/ft (72 LEDs/m)	49.2ft (15m) / N/A	98.4ft (30m) / N/A	44ft (13m)	3 SDCM	2725 ± 85K	82-87	2.3SDCM	40lm/ft (130lm/m)	SF09A1012WE27K12DV
3000K	22 LEDs/ft (72 LEDs/m)	49.2ft (15m) / N/A	98.4ft (30m) / N/A	44ft (13m)	3 SDCM	3045 ± 105K	82-87	2.3SDCM	40lm/ft (130lm/m)	SF09A1012WE30K12DV
3500K	22 LEDs/ft (72 LEDs/m)	49.2ft (15m) / N/A	98.4ft (30m) / N/A	44ft (13m)	3 SDCM	3465 ± 245K	82-87	2.3SDCM	40lm/ft (130lm/m)	SF09A1012WE35K12DV
4000K	22 LEDs/ft (72 LEDs/m)	49.2ft (15m) / N/A	98.4ft (30m) / N/A	44ft (13m)	3 SDCM	3985 ± 150K	82-87	2.3SDCM	40lm/ft (130lm/m)	SF09A1012WE40K12DV
5700K	22 LEDs/ft (72 LEDs/m)	49.2ft (15m) / N/A	98.4ft (30m) / N/A	44ft (13m)	3 SDCM	5669 ± 305K	82-87	2.3SDCM	40lm/ft (130lm/m)	SF09A1012WE57K12DV

\*Run length is based on a static full load with voltage drop calculated using a 0.3 m (0.98 ft) cable with silicone seamless connectors, excluding connector length—refer to specifications for details. For runs over 65.62ft (20m), recommended to limit each to 65.62ft (20m) for easier handling. \*\*For UL Class 2 calculations, GLLS uses a maximum output of 60 W / 60 VA for 12 V circuits, unless otherwise confirmed by the listed driver. All runs are assumed to be single-feed from one Class 2 output. Dual-feeding from separate drivers does not qualify as Class 2 unless the run is electrically split into isolated sections. \*\*\*Silicone products maintain ≤3 SDCM within a single production run and <5 SDCM between production runs.



# VIVID CONTOUR: SILICONE - 12V

Indoor & Outdoor Rated Linear Flex Profile - Static Whites & Colors



## C

### POWER & VOLTAGE

COLOR	VOLTAGE + CIRCUIT TYPE	POWER CONSUMPTION
RED	12V DC CV	1.37W/ft (4.5W/m)
GREEN		
BLUE		
AMBER		
2200K		
2700K		
3000K		
3500K		
4000K		
5700K		

## D

### CUTTING INSTRUCTIONS

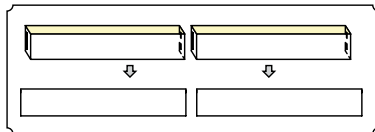
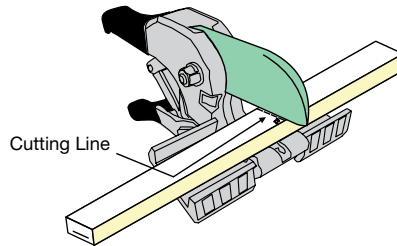
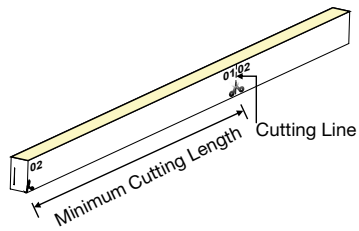

COLOR	ORDER UNIT (CUTTING UNIT)
RED	1.64in (41.7mm) (3 LEDs)
GREEN	
BLUE	
AMBER	
2200K	
2700K	
3000K	
3500K	
4000K	
5700K	



# VIVID CONTOUR: SILICONE - 12V

Indoor & Outdoor Rated Linear Flex Profile - Static Whites & Colors



E

## COMPATIBLE CONNECTORS

### INPUT - 01

PROFILE	BENDING	WIRING	INPUT CONNECTOR TYPE	INPUT ORIENTATION + TYPE	INPUT CABLE LENGTH (LEAD WIRE)
---------	---------	--------	----------------------	--------------------------	--------------------------------

### OUTPUT - 02

PROFILE	BENDING	WIRING	OUTPUT CONNECTOR TYPE	OUTPUT ORIENTATION + TYPE	OUTPUT CABLE LENGTH (LEAD WIRE)
B = Contour	1 = Side	1 = 2 Wire (Static) 0 = N/A (End Cap)	6 = Swivel	A = End Exit I = End Cap	1 = 0.98ft (0.3m) 2 = 3.28ft (1m) 8 = N/A
			7 = Snap	A = End Exit B = Bottom Exit C = Side Left Exit D = Side Right Exit E = End Jumper H = Power T-Feed I = End Cap	1 = 0.98ft (0.3m) 2 = 3.28ft (1m) 3 = 9.84ft (3m) 4 = 16ft (5m) 5 = 32.81ft (10m) 6 = 49.21ft (15m) 7 = 65.62ft (20m) 8 = N/A
			8 = Click	A = End Exit I = End Cap	1 = 0.98ft (0.3m) 2 = 3.28ft (1m) 3 = 9.84ft (3m) 4 = 16ft (5m) 8 = N/A
			2 = Silicone Seamless	A = End Exit B = Bottom Exit C = Side Left Exit D = Side Right Exit E = End Jumper H = Power T-Feed I = End Cap	1 = 0.98ft (0.3m) 2 = 3.28ft (1m) 3 = 9.84ft (3m) 4 = 16ft (5m) 5 = 32.81ft (10m) 6 = 49.21ft (15m) 7 = 65.62ft (20m) 8 = N/A

## LEGACY CONNECTOR ORDER CODE

XX	09A	1	01	XX	SE	X	XX	XXX	X
PRODUCT TYPE	profile	BENDING	light emitting	functionality	connector type	fixture end	exit type	length	
NA = DIY Accessories FA = Factory Accessories	09A = Contour	1 = Side	01 = 09A	2W = Static 0W = For End Cap	SV = Swivel CL = Click SC = Snap SE = Seamless	1 = Input Side 2 = Output Side 0 = Jumpers/T-feeds/ Seamless Bottom/ Seamless End 3 = 01 Input/02 Output	EN = End BO = Bottom SL = Side Left SR = Side Right EJ = End Jumper BJ = Bottom Jumper TF = Power Feed EC = End Cap	0M3 = 0.98ft (30cm) 01M = 3.28ft (1m) 03M = 9.84ft (3m) 05M = 16ft (5m) 10M = 32.81ft (10m) 000 = For End Cap	P = Power or For End Cap S = Signal & Power



# VIVID CONTOUR: SILICONE - 12V

Indoor & Outdoor Rated Linear Flex Profile - Static Whites & Colors



## E

### SWIVEL CONNECTOR



**NOTES:**

1. Connector Tolerance  $\pm 0.02$ in (0.5mm)
2. Cable diameter: Static Silicone = 0.26in (6.5mm)
3. Do not apply force to the feed cable
4. Ensure Max. Cable Lengths are followed according to wire gage to avoid voltage drop

IP20, Omni-directional Cable, Tool-less, Mini Size. Recommended for indoor dry environments and for onsite length adjustments. Under the simple and convenient design concept, we developed our swivel connector, which is superb for indoor concealed installation in narrow space thanks to its mini size and omni-directional cable. Navigated by user manual, tool-free and quick assembly can be realized, and Press & Seal design enables the functions of energization and dust-proof rapidly. DIY or custom factory assembly.

#### END EXIT: B116A#

#### END CAP: B106I#

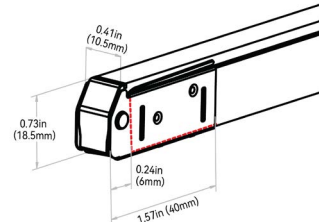
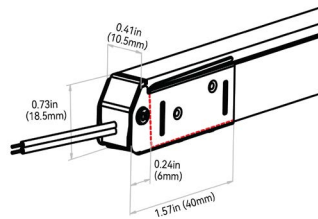

# VIVID CONTOUR: SILICONE - 12V

Indoor & Outdoor Rated Linear Flex Profile - Static Whites & Colors



## E

### SNAP CONNECTOR



**NOTES:**

1. Connector Tolerance  $\pm 0.02$ in (0.5mm)
2. Cable diameter: Static Silicone = 0.26in (6.5mm)
3. Do not apply force to the feed cable
4. Ensure Max. Cable Lengths are followed according to wire gage to avoid voltage drop

IP67, tool-less; good solution for protection from water ingress; larger connector & anti-wicking ferrule. Recommended for wet environments and on-site length adjustments. To seal the end of light and ensure the waterproof in case of any cutting or extension on site, Insulfit technology prevents the water or vapor ingress from the end of the light. DryWire technology applied on the cable eliminates the capillary phenomenon through wires, which secured the long-term reliability in any wading environments. DIY or custom factory assembly.

### END EXIT: B117A#

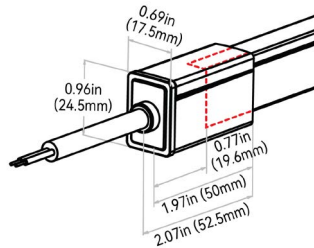

### END CAP: B107I8

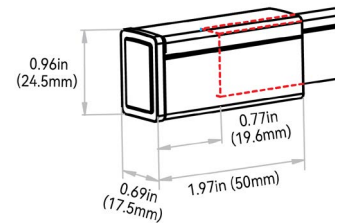

### SCREW LOCK CONNECTOR ACCESSORY - IP67

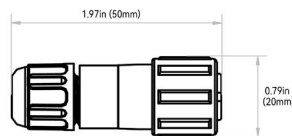

NOTE: The tolerance is  $\pm 0.08$ in (2mm).

### ANTI-WICKING FERRULE:

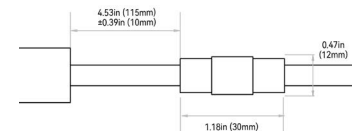

**NOTES:**

1. The anti-wicking ferrule is located at 4.53in (115mm) ( $\pm 0.39$ in [ $\pm 10$ mm] tolerance) from the connector on the cable. For protection against water ingress.
2. The removal of anti-wicking ferrule will void the warranty if any water ingress caused by it.



# VIVID CONTOUR: SILICONE - 12V

Indoor & Outdoor Rated Linear Flex Profile - Static Whites & Colors



## E

**BOTTOM EXIT: B117B#**

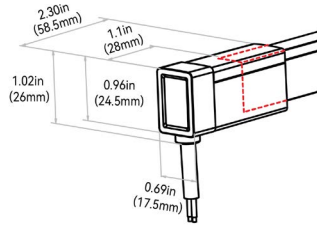

**END JUMPER: B117E1**

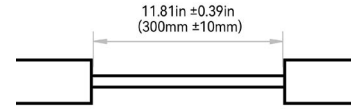

**SIDE LEFT EXIT: B117C#**

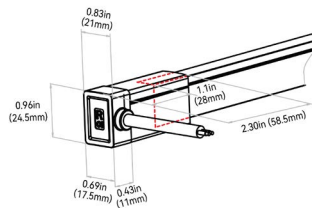

**POWER T-FEED: B117H#**

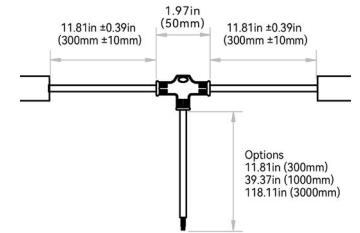

**SIDE RIGHT EXIT: B117D#**

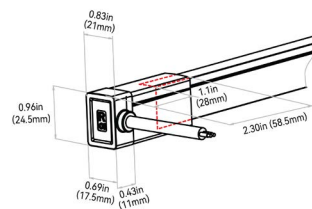

# VIVID CONTOUR: SILICONE - 12V

Indoor & Outdoor Rated Linear Flex Profile - Static Whites & Colors



## E

### CLICK CONNECTOR

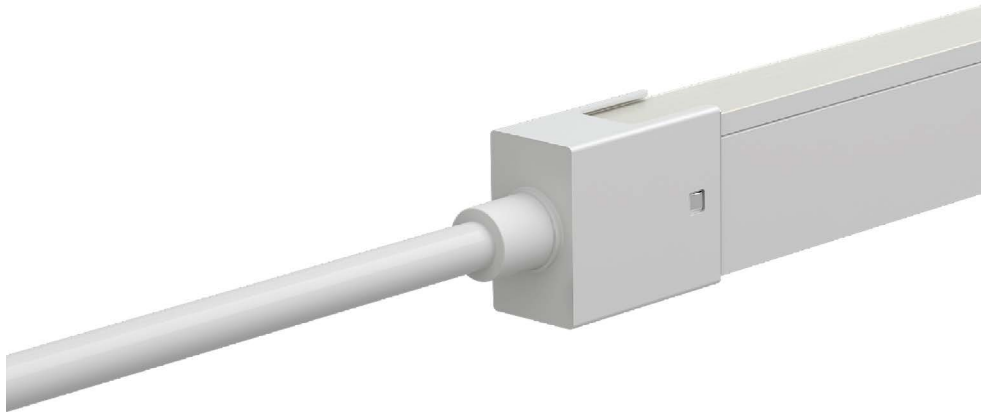

**NOTES:**

1. Connector Tolerance  $\pm 0.02$ in (0.5mm)
2. Cable diameter: Static Silicone = 0.26in (6.5mm)
3. Do not apply force to the feed cable
4. Ensure Max. Cable Lengths are followed according to wire gage to avoid voltage drop

IP67; tool-less & mini size. Recommended for outdoor environments & for onsite length adjustments. Click connector, a new type of field-assembly connector for outdoor use, brass casing, features unexceptional adaptability and excellent weather resistance. It achieves the unique balance between waterproof performance and physical dimension, highly functional yet incredibly minimal, giving you an extraordinary visual experience due to the less dark area at the jointing area. The whole assembling process is tool-less and quick, benefiting from its simple but smart structure design. The remarkable innovation lies in the invisible waterproof pretreatment on the cable, which facilitates the wiring and slotting on the site greatly as the extra anti-wicking ferrule on the cable is no longer needed. DIY or custom factory assembly.

### END EXIT: B118A#

### END CAP: B108I8

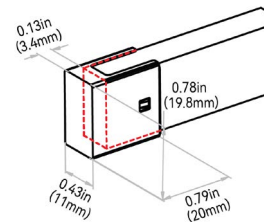
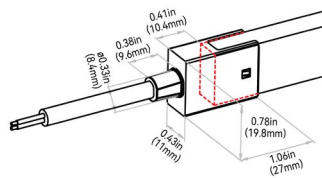

### SCREW LOCK CONNECTOR ACCESSORY - IP67

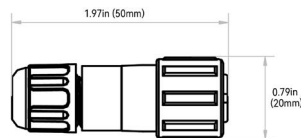

NOTE: The tolerance is  $\pm 0.08$ in (2mm).



# VIVID CONTOUR: SILICONE - 12V

Indoor & Outdoor Rated Linear Flex Profile - Static Whites & Colors



## E

### SILICONE SEAMLESS CONNECTOR



- NOTES:
1. Connector Tolerance  $\pm 0.02$ in (0.5mm)
  2. Cable diameter: Static Silicone = 0.26in (6.5mm)
  3. Do not apply force to the feed cable
  4. Ensure Max. Cable Lengths are followed according to wire gage to avoid voltage drop

IP68; seamless; precise low profile dimension; high grade quality silicone & anti-wicking ferrule. Recommended for; wet environments; custom predetermined lengths; high/ low temperatures; increased humidity; direct UV exposure; harsh working conditions & increased handling forces during installation. Precision milling and special glue Silicone liquid injection-moulded workmanship enables an almost consistent size between connectors and lightbody, and the transparent terminal of the connector allows the seamless effects spliced end by end. DryWire technology applied on the cable eliminates the capillary phenomenon through wires, which secured the long-term reliability in outdoor or any wet environments. Custom factory assembly.

#### END EXIT: B112A#

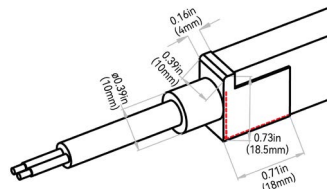

#### END CAP: B102I8

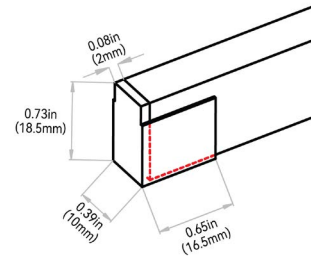

#### SCREW LOCK CONNECTOR ACCESSORY - IP67

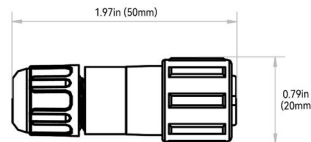

#### ANTI-WICKING FERRULE:

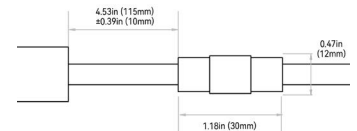

NOTE: The tolerance is  $\pm 0.08$ in (2mm).

- NOTES:
1. The anti-wicking ferrule is located at 4.53in (115mm) ( $\pm 0.39$ in [ $\pm 10$ mm] tolerance) from the connector on the cable. For protection against water ingress.
  2. The removal of anti-wicking ferrule will void the warranty if any water ingress caused by it.



# VIVID CONTOUR: SILICONE - 12V

Indoor & Outdoor Rated Linear Flex Profile - Static Whites & Colors



## E

**BOTTOM EXIT: B112B#**

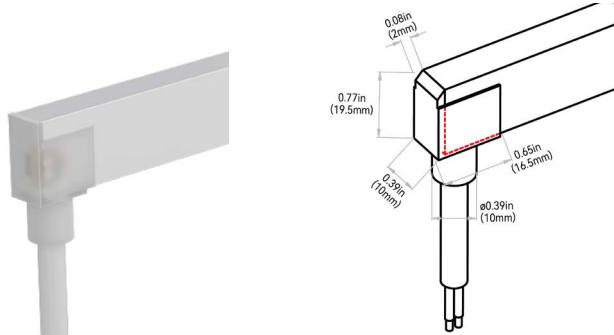

**END JUMPER: B112E1**

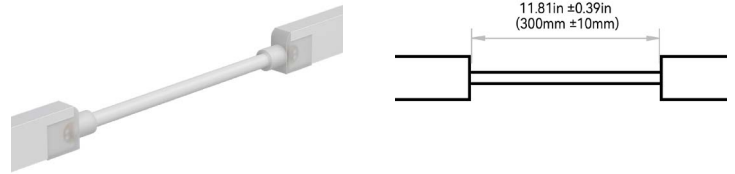

**SIDE LEFT EXIT: B112C#**

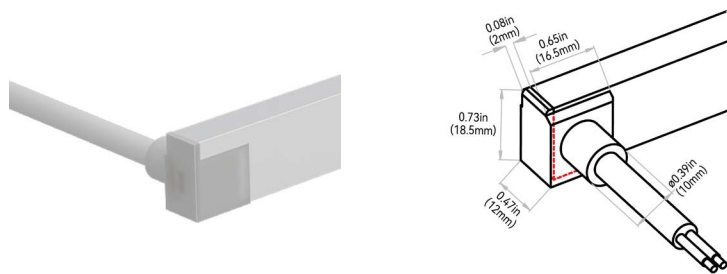

**POWER T-FEED: B112H#**

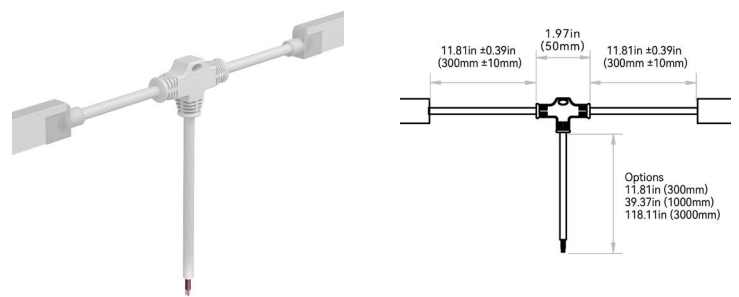

**SIDE RIGHT EXIT: B112D#**

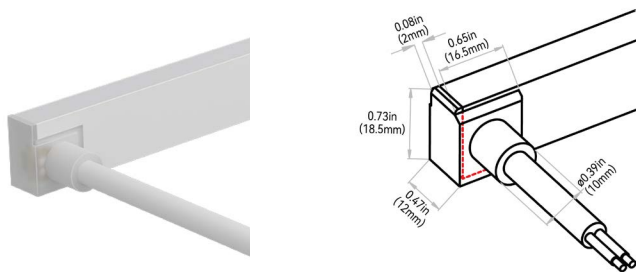

# VIVID CONTOUR: SILICONE - 12V

Indoor & Outdoor Rated Linear Flex Profile - Static Whites & Colors



## F

### MOUNTING PROFILES

MOUNTING PROFILE TYPE	STANDARD LENGTH	PROFILE	COLOR	BEND
A1 = Aluminum Basic	2 = 1.38in (35mm) 3 = 19.68in (500mm) 5 = 39.37in (1000mm) 6 = 78.74in (2000mm)	B = Contour	1 = Standard	1 = Side
A2 = Aluminum Recessed	2 = 1.38in (35mm) 3 = 19.68in (500mm) 5 = 39.37in (1000mm) 6 = 78.74in (2000mm)			
A3 = Aluminum Recessed Silicone Grip	1 = 0.79in (20mm) 3 = 19.68in (500mm) 5 = 39.37in (1000mm) 6 = 78.74in (2000mm)			
A4 = Aluminum Silicone Grip	1 = 0.79in (20mm) 3 = 19.68in (500mm) 5 = 39.37in (1000mm) 6 = 78.74in (2000mm)			
A5 = Aluminum Flexible	3 = 19.68in (500mm) 5 = 39.37in (1000mm)			

### ALUMINUM PROFILE - BASIC

High-quality 6063 aluminum with thin-wall, light-weight design to fit the fixture tightly. It is deformation and rust resistant, and cost-effective. Please refer to install manual for proper installation practices..

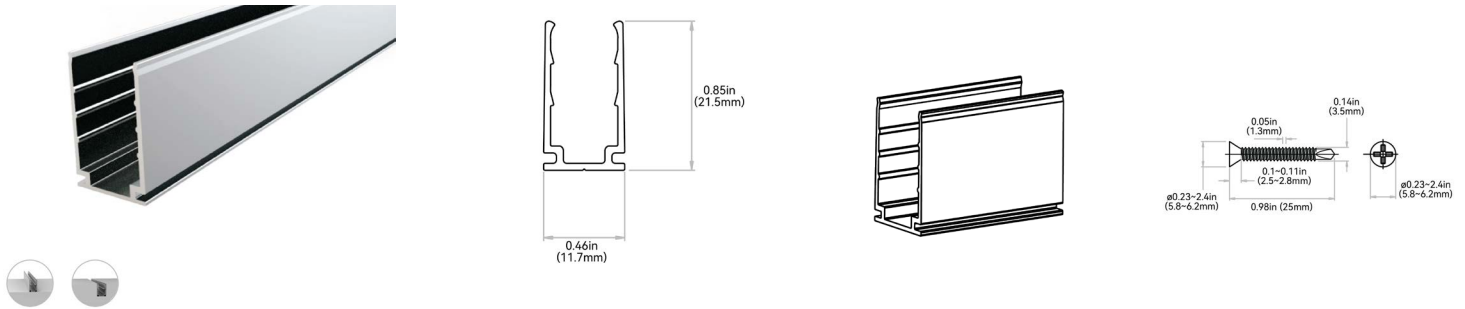

Tolerance: ± 0.01in (0.3mm)

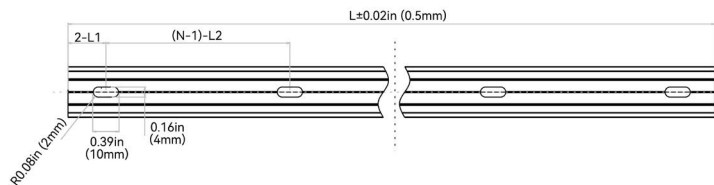

NOTES: 1. 2-L1 refers to two of symmetric L1 in each piece of profile.  
2. (N-1)-L2 refers to (N minus one) of symmetric L2 in each piece of profile. "N" hereby stands for its corresponding "Hole Number" in the below table

ORDER CODE	LEGACY CODE	STANDARD LENGTH	L1	L2	SLOTTED HOLE	HOLE #
A12B11	CL09RAL3C5SD	1.38in (35mm)	0.69in (17.5mm)	N/A	0.16*0.39in (4*10mm)	1
A13B11	CH09RAL0M5SD	19.68in (500mm)	1.97in (50mm)	7.87in (200mm)	0.16*0.39in (4*10mm)	3
A15B11	CH09RAL01MSD	39.37in (1000mm)	3.93in (100mm)	7.87in (200mm)	0.16*0.39in (4*10mm)	5
A16B11	CH09RAL02MSD	78.74in (2000mm)	3.93in (100mm)	7.87in (200mm)	0.16*0.39in (4*10mm)	10



# VIVID CONTOUR: SILICONE - 12V

Indoor & Outdoor Rated Linear Flex Profile - Static Whites & Colors



## F

### ALUMINUM PROFILE - RECESSED

High-quality 6063 aluminum with thin-wall, light-weight design to fit the fixture tightly. Recommended on projects with lighting mounted recessed in a cavity so only the lens is shown. It is deformation and rust resistant, and cost-effective. Please refer to install manual for proper installation practices.

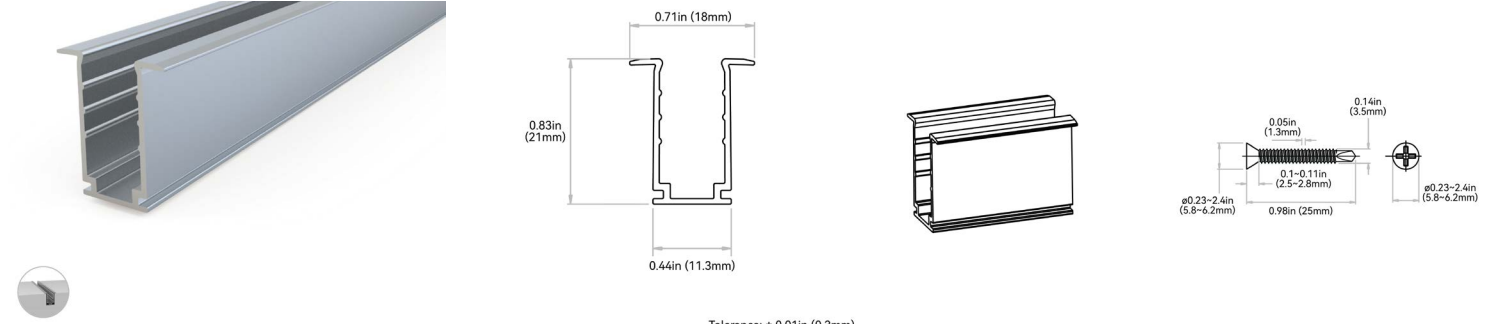

NOTES: 1. 2-L1 refers to two of symmetric L1 in each piece of profile.  
2. (N-1)-L2 refers to (N minus one) of symmetric L2 in each piece of profile.  
"N" hereby stands for its corresponding "Hole Number" in the below table

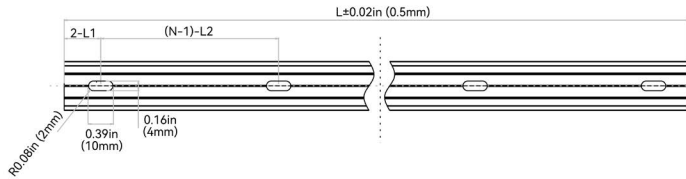

ORDER CODE	LEGACY ORDER CODE	STANDARD LENGTH	L1	L2	SLOTTED HOLE	HOLE #
A22B11	CL09RRA3C5SD	1.38in (35mm)	0.69in (17.5mm)	N/A	0.16*0.39in (4*10mm)	1
A23B11	CH09RRA0M5SD	19.68in (500mm)	1.97in (50mm)	7.87in (200mm)	0.16*0.39in (4*10mm)	3
A25B11	CH09RRA01MSD	39.37in (1000mm)	3.93in (100mm)	7.87in (200mm)	0.16*0.39in (4*10mm)	5
A26B11	CH09RRA02MSD	78.74in (2000mm)	3.93in (100mm)	7.87in (200mm)	0.16*0.39in (4*10mm)	10

### ALUMINUM PROFILE - SILICONE GRIP

High-quality 6063 aluminum with thin-wall, light-weight design. Includes a serrated silicone grip insert designed to hold fixture with additional force. Recommended on projects mounted upside down. It is deformation and rust resistant, and cost-effective. Please refer to install manual for proper installation practices.

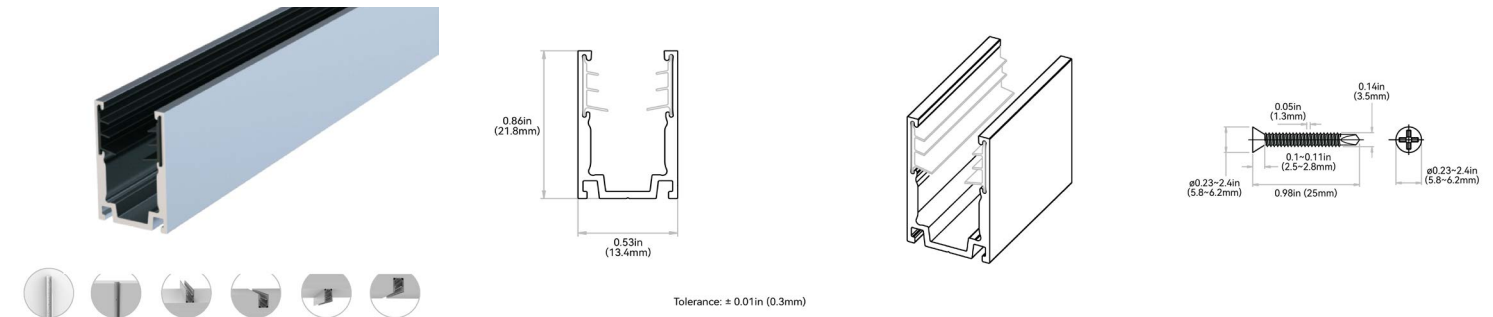

NOTES: 1. 2-L1 refers to two of symmetric L1 in each piece of profile.  
2. (N-1)-L2 refers to (N minus one) of symmetric L2 in each piece of profile.  
"N" hereby stands for its corresponding "Hole Number" in the below table

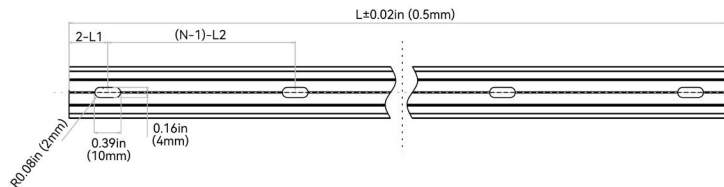

ORDER CODE	LEGACY ORDER CODE	STANDARD LENGTH	L1	L2	SLOTTED HOLE	HOLE #
A41B11	CL09RAL02CSE	0.79in (20mm)	0.39in (10mm)	N/A	0.16*0.39in (4*10mm)	1
A43B11	CH09RAL0M5SE	19.68in (500mm)	1.97in (50mm)	7.87in (200mm)	0.16*0.39in (4*10mm)	3
A45B11	CH09RAL01MSE	39.37in (1000mm)	3.93in (100mm)	7.87in (200mm)	0.16*0.39in (4*10mm)	5
A46B11	CH09RAL02MSE	78.74in (2000mm)	3.93in (100mm)	7.87in (200mm)	0.16*0.39in (4*10mm)	10



# VIVID CONTOUR: SILICONE - 12V

Indoor & Outdoor Rated Linear Flex Profile - Static Whites & Colors



F

## ALUMINUM PROFILE - RECESSED - SILICONE GRIP

High-quality 6063 aluminum with thin-wall, light-weight design to fit the fixture tightly. Includes a serrated silicone grip insert designed to hold fixture with additional force. Recommended on projects mounted upside down with lighting mounted recessed in a cavity so only the lens is shown. It is deformation and rust resistant, and cost-effective. Please refer to install manual for proper installation practices.

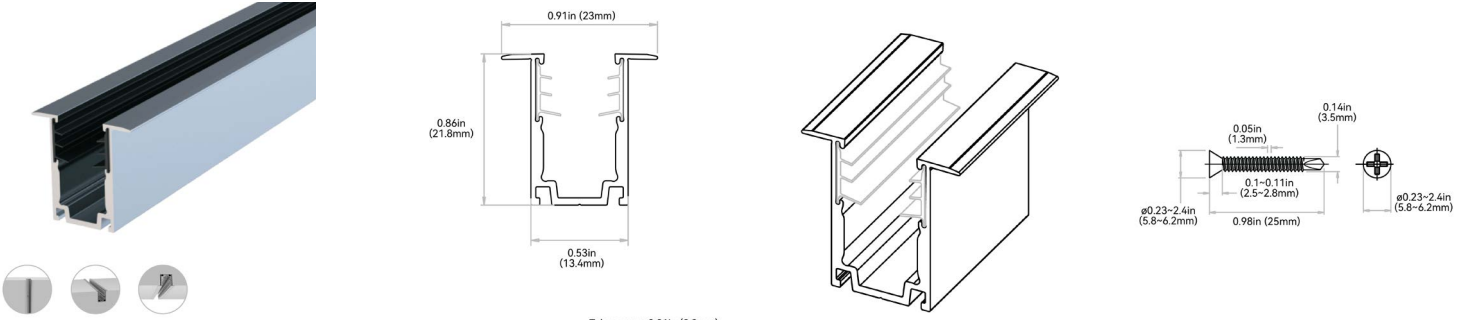

NOTES: 1. 2-L1 refers to two of symmetric L1 in each piece of profile.  
2. (N-1)-L2 refers to (N minus one) of symmetric L2 in each piece of profile. "N" hereby stands for its corresponding "Hole Number" in the below table

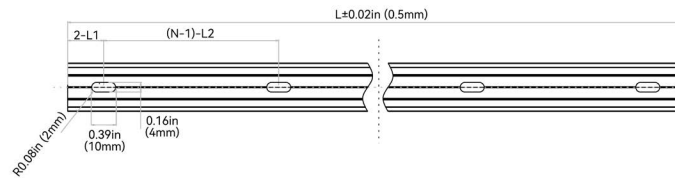

ORDER CODE	LEGACY ORDER CODE	STANDARD LENGTH	L1	L2	SLOTTED HOLE	HOLE #
A31B11	CL09RRA02CSE	0.79in (20mm)	0.39in (10mm)	N/A	0.16*0.39in (4*10mm)	1
A33B11	CH09RRA0M5SE	19.68in (500mm)	1.97in (50mm)	7.87in (200mm)	0.16*0.39in (4*10mm)	3
A35B11	CH09RRA01MSE	39.37in (1000mm)	3.93in (100mm)	7.87in (200mm)	0.16*0.39in (4*10mm)	5
A36B11	CH09RRA02MSE	78.74in (2000mm)	3.93in (100mm)	7.87in (200mm)	0.16*0.39in (4*10mm)	10

## ALUMINUM PROFILE - FLEXIBLE

It is an expanded design of the flexible aluminum profile, and caters for the continuously streamlined aesthetics of curve shape. The secondary precision cutting process, not only maintains the advantage of clamping force, but also enables the two-way side bending directions with super shape memory. Please refer to install manual for proper installation practices.

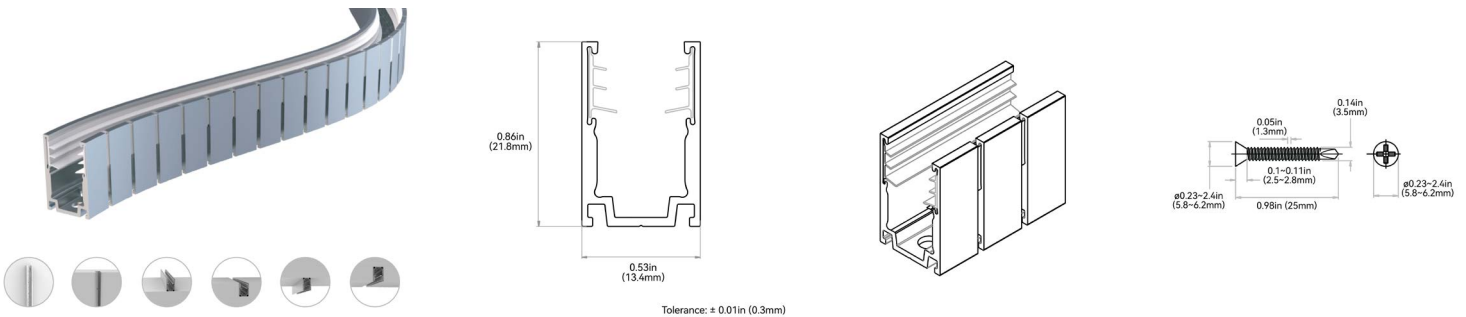

NOTES: 1. 2-L1 refers to two of symmetric L1 in each piece of profile.  
2. (N-1)-L2 refers to (N minus one) of symmetric L2 in each piece of profile. "N" hereby stands for its corresponding "Hole Number" in the below table

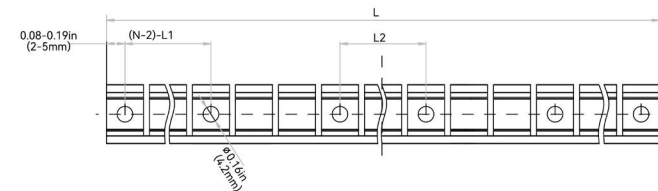

ORDER CODE	LEGACY ORDER CODE	STANDARD LENGTH	L1	L2	SLOTTED HOLE	HOLE #
A53B11	CH09FAL0M5SE	19.68in (500mm)	4.34in (110.3mm)	1.92in (48.9mm)	Ø 0.17in (4.2mm)	6
A55B11	CH09FAL01MSE	39.37in (1000mm)	4.59in (116.5mm)	3.89in (98.8mm)	Ø 0.17in (4.2mm)	10



**G**

**MOUNTING ACCESSORIES**

MOUNTING ACCESSORY TYPE	PROFILE
MA1 = Pivot Bracket	O = All Profiles
MA2 = Rotary Bracket	
MA3 = Side Bracket	
MA4 = Ceiling Clip	B = Contour
MA5 - Suspended Rod + Clip	
MA6 = Suspended Wire Kit	
MA7 = Alignment Bracket - Aluminum Basic	
MA8 = Alignment Bracket - Aluminum Silicone Grip	

**PIVOT BRACKET: MA10 | MA00PMB0000**

Applicable to all mounting profiles.

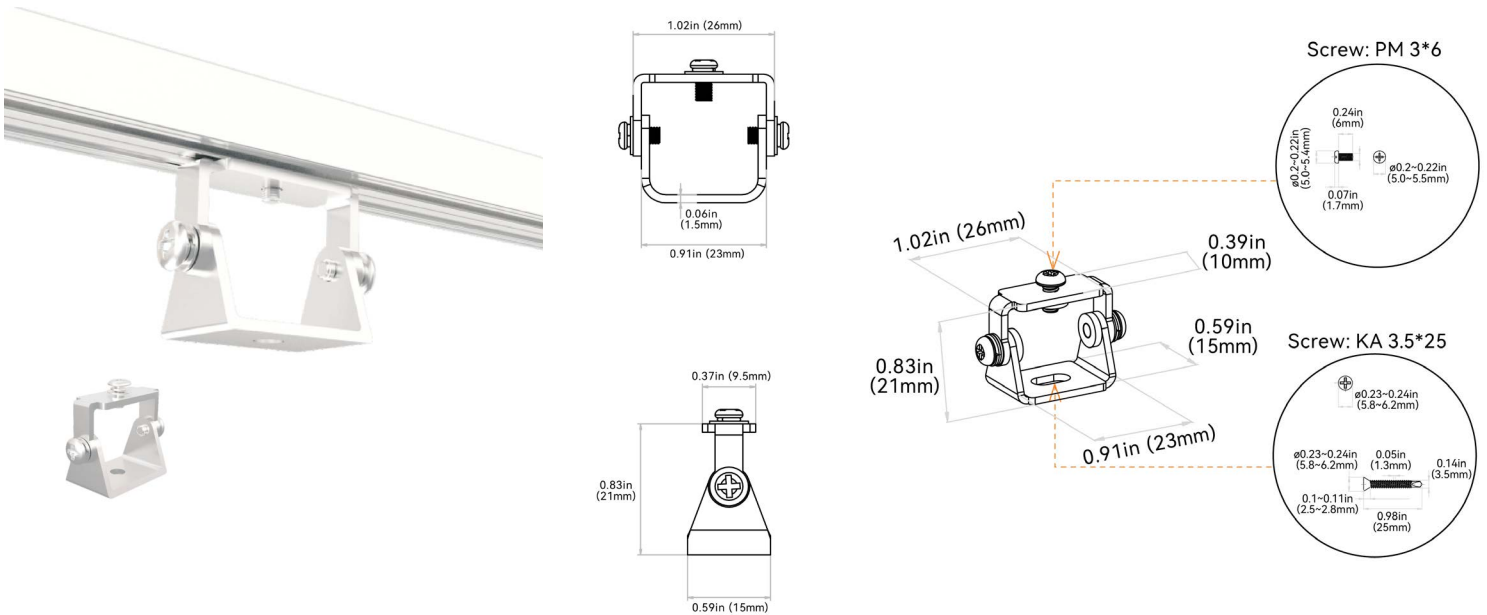

# VIVID CONTOUR: SILICONE - 12V

Indoor & Outdoor Rated Linear Flex Profile - Static Whites & Colors



## G

### ROTARY BRACKET: MA20 | MA00BRL00000

Applicable to all mounting profiles.

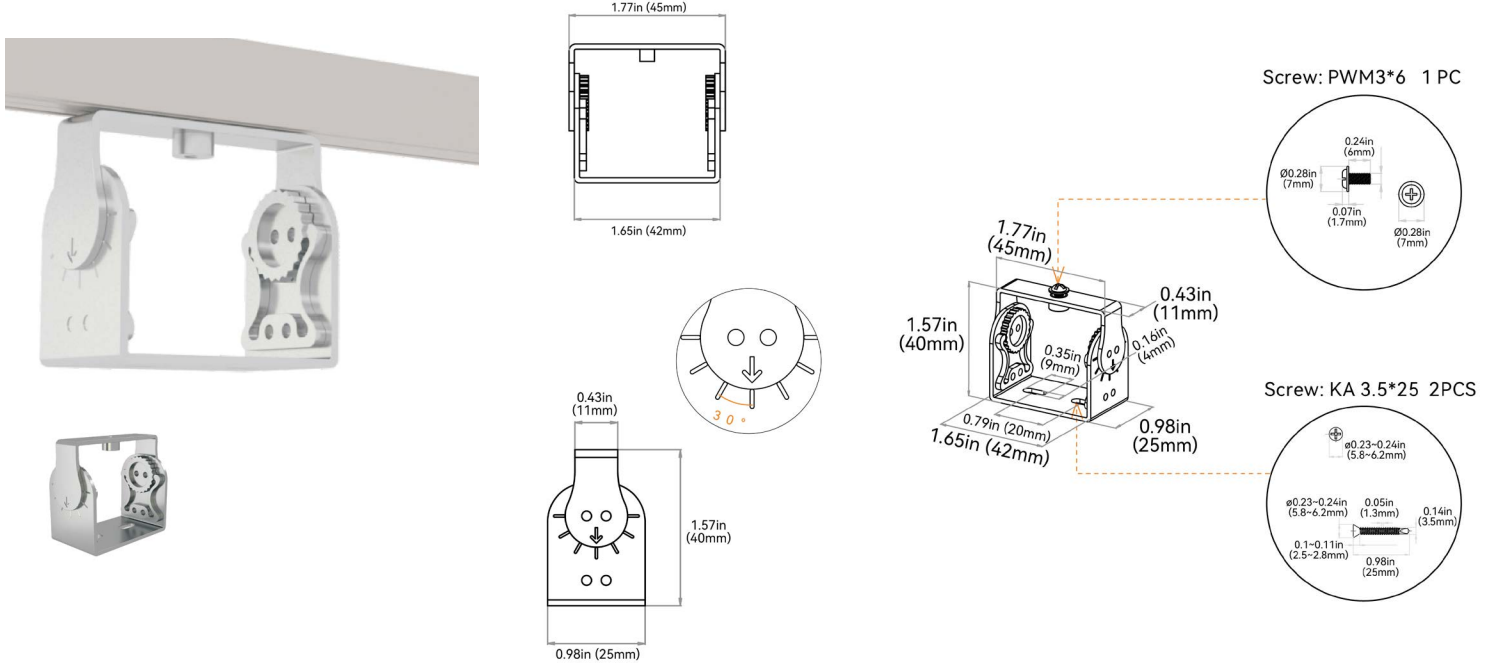

### SIDE MOUNTING BRACKET: MA30 | MA00SMB00000

Applicable to all mounting profiles.

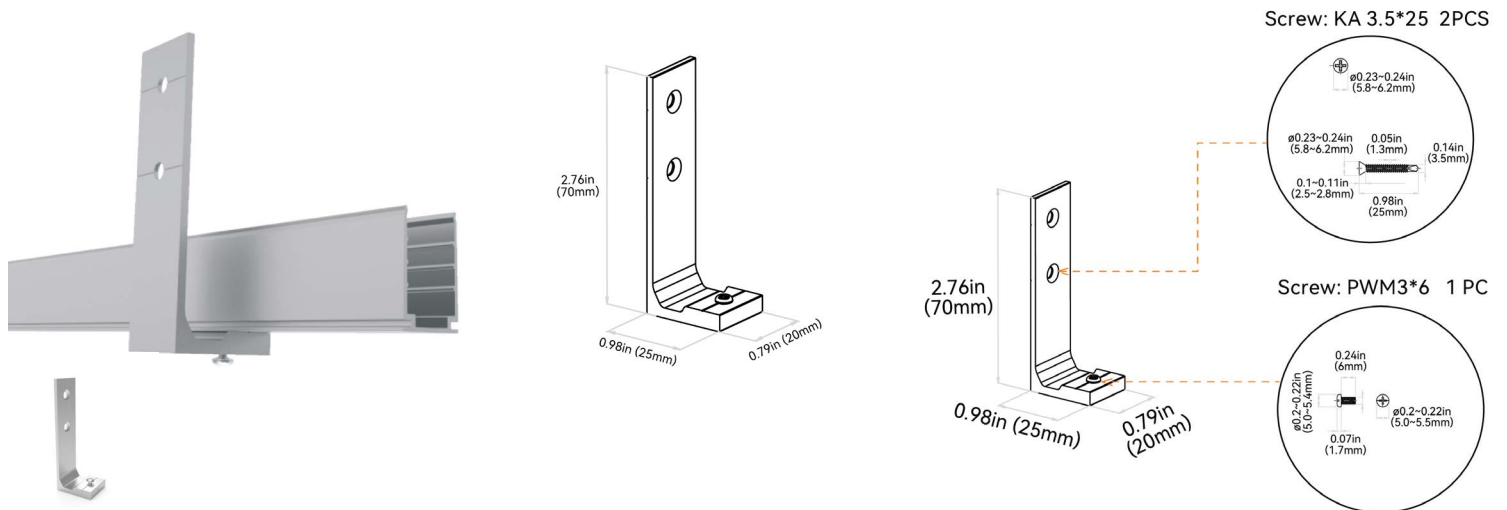

# VIVID CONTOUR: SILICONE - 12V

Indoor & Outdoor Rated Linear Flex Profile - Static Whites & Colors



G

## CEILING CLIP BRACKET: MA4B | MA00CMC00000

Applicable to aluminum profile - recessed - silicone grip

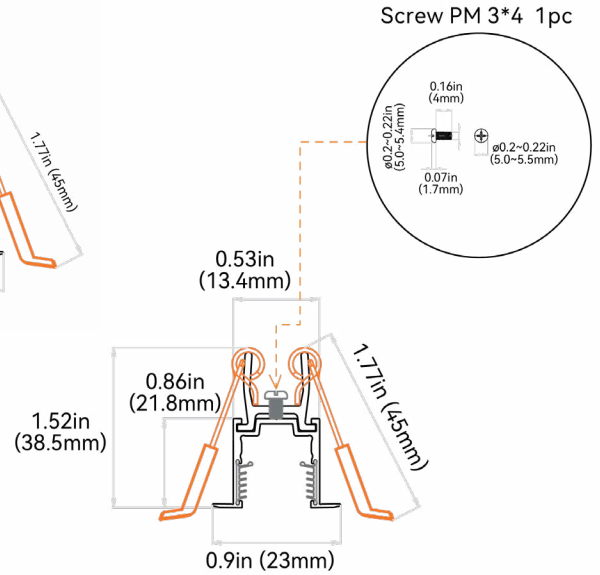
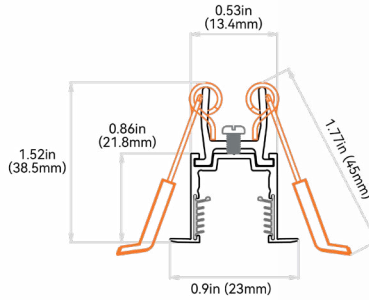

## SUSPENDED WIRE: MA6B | MA09SMC000SW

Applicable to Aluminum Profile - Silicone Grip. 2 kits of stainless steel wires for 39.37in (1000mm) of profile & 3 kits of stainless steel wires for 78.74in (2000mm) of profile.

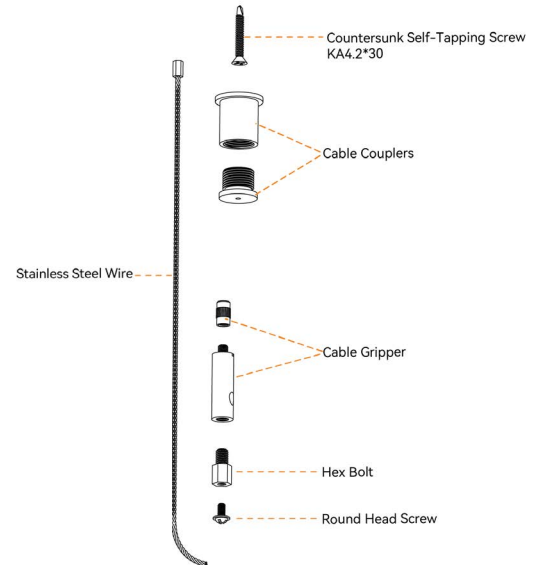
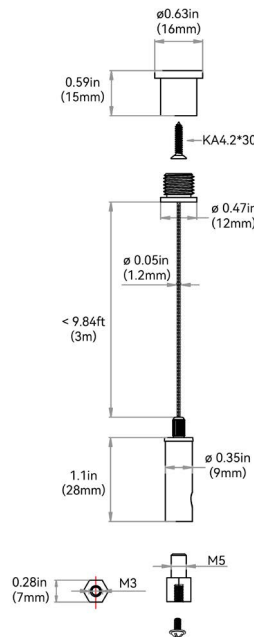

# VIVID CONTOUR: SILICONE - 12V

Indoor & Outdoor Rated Linear Flex Profile - Static Whites & Colors



## G

### SUSPENDED MOUNTING CLIP + ROD: MA5B | MA09SMC0M5SR

Applicable to all mounting profiles.

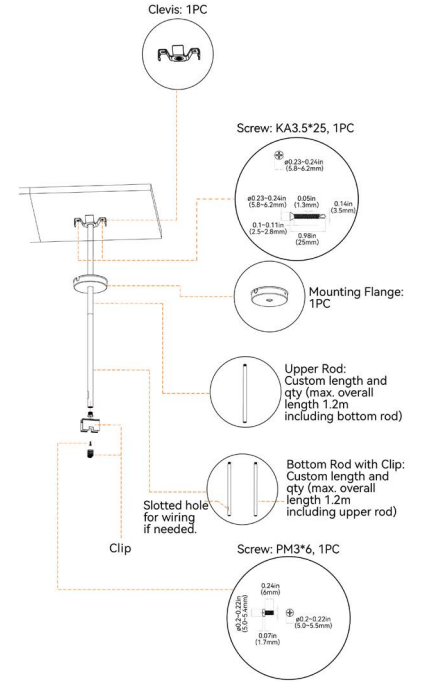
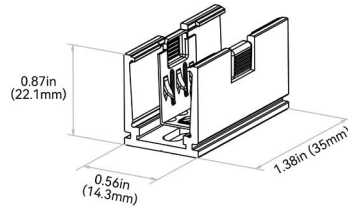

### ALIGNMENT BRACKET - ALUMINUM BASIC: MA7B | CH09AL0M45JB

Applicable to aluminum basic

### ALIGNMENT BRACKET - ALUMINUM SILICONE GRIP: MA8B | CH09RAL0M45JB

Applicable to aluminum silicone grip

