

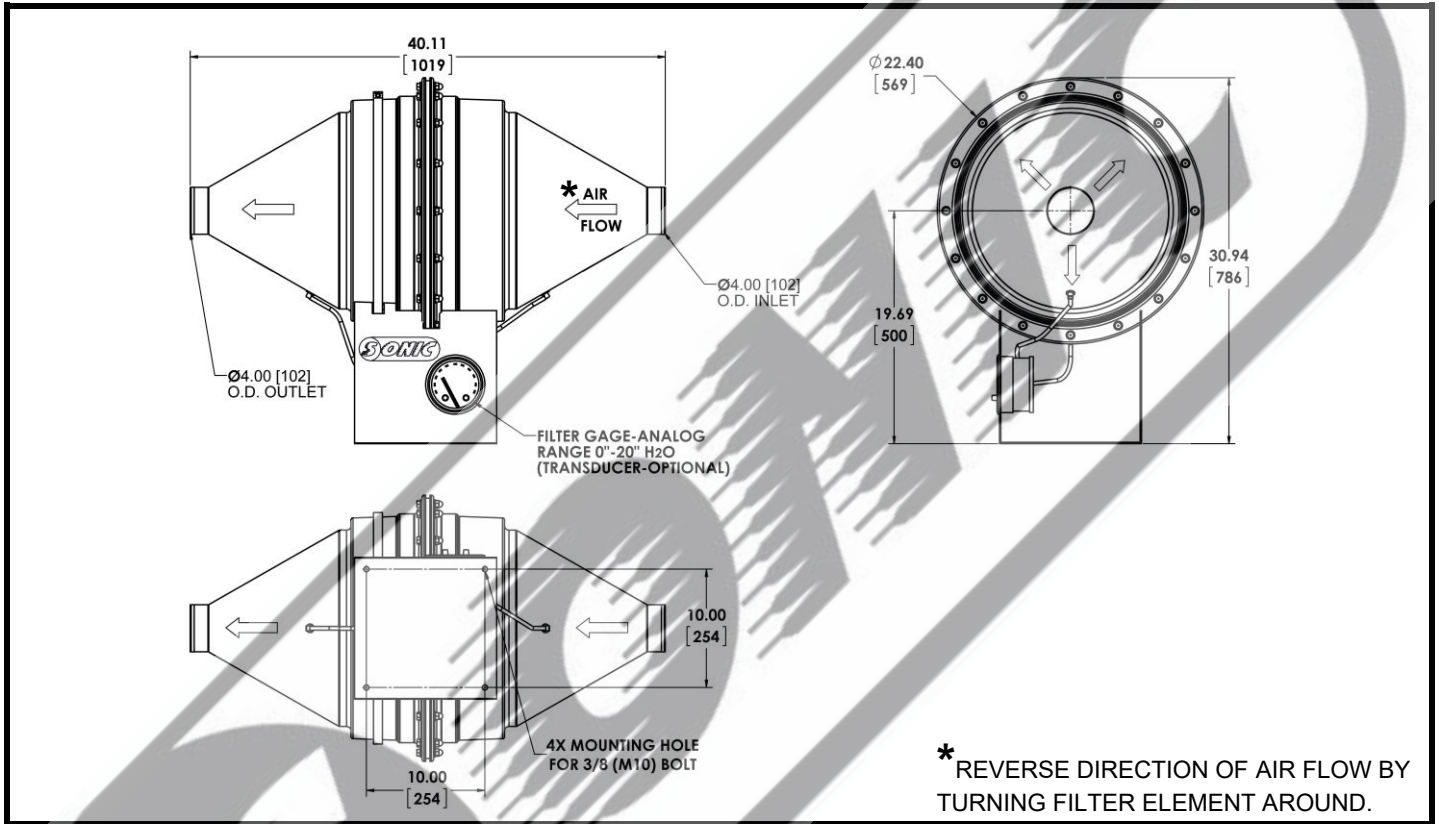

Product Specification Sheet  
**HEPA AIR FILTER**  
**IN-LINE AFTER BLOWER**  
**99.97% @ 0.3 MICRON MERV 17**



Description	Air Filter- HEPA 150° F Max. Temp.	Air Filter- VT Blower HEPA 180° F Max. Temp.
Filter Properties	½" x 18" Dia. Pre-Filter Pad 0.3 micron Element / Merv 17	
Replacement Element Kit P/N	12148	15714
Maximum Flow Rate + (P1/P2)	1,000 CFM (28 CMM) @3" H2O Differential	700 CFM (20 CMM) @3" H2O Differential
Maximum Differential Pressure (FILTER LOADING)	(P1/P2) = 2.0 psig (1407 mm H2O)	
Maximum Air Temperature	150° F (65° C)	180° F (82° C)
Max. Air Blower Pressure	4.2 PSIG (28.9 Kpa)	
Material-Housing + Base	Housing: Hard Anodized 6061 Aluminum Base: Powder Coated Steel	
Finish – Options (As in Photo)	Housing: Electroless Nickel Plated Base: Electropolished Stainless Steel Inlet/Outlet Connection: 4" & 6" Dia Hose or Ferrule	
Weight (Approx.)	46 lbs (21 Kg)	50 lbs (23 Kg)
Sonic Part Number	Call Sonic Air Systems	Call Sonic Air Systems