

 **DMEA**

CONSTRUCTION HANDBOOK

**NEW CONSTRUCTION SERVICES
AND ENGINEERING**

1-877-687-3632 • www.dmea.com

TABLE OF CONTENTS

General Information

Application for Service	2
Design and Construction Cost	2
Scheduling and Site Readiness	3
Before New Service Can Be Energized	3
Extra Trip Fee for Construction Delay	3
CALL BEFORE YOU DIG – COLORADO 811	3
Right-of-Way Easements and Access	4
Plant Investment Fee	4
Special Considerations for Motor Loads	4
Load Balance	4
Short Circuit Current, Fault Current and Arc Flash	5

Electrical Safety Code Clearances 5

Vegetation Management 7

Specifications for Meter Installations

General	8
Electric Meter Locations	8
Self-Contained Metering Installations	9
Instrument Transformer (CT) Metering Installations	10
Single Member or Multiple Members – CT Metering	10

Colorado State Electrical Inspections 11

Working Clearances from Electric Meter 12

Underground Service Installations

Meter Base on House or Building	13
Meter Pedestal, Permanent and Temporary	14
Trenching Specifications - Primary and Secondary	15
Joint Use Trench	16

Overhead Service Installations

Overhead Temporary Service	16
Permanent Service - Mast on Building	17

Developer Policy 18

DMEA is “Your Rural Electric CO-OP” 19

Notes 20

Customer Construction Check-off List 21

Commercial Load Data Form 22

GENERAL INFORMATION

Application for Service

All applications for service from Delta-Montrose Electric Association (DMEA) shall be in accordance with its Extension Policy and Electric Service Regulations. In all circumstances the applicant shall be the fee owner of the property to be serviced by the extension.

By DMEA policy, all electric facilities beyond the meter (Point of Delivery) are constructed by, owned by and the responsibility of the member. Installation of all facilities on the DMEA side of the meter, including the transformer, are designed and installed by DMEA and becomes the property of DMEA unless otherwise noted. It is the responsibility of DMEA to operate and maintain all assets on its side of the meter.

The first step in starting new construction is to go online at www.dmea.com/new-construction-information and fill out a ‘**Request for DMEA System Design Services**’. Once you fill out and email the Request to csrs@dmea.com, someone will be giving you a call to complete the application process and to obtain a construction advance. The advance will go towards expenses such as those incurred as part of the design process, and will be applied towards the final cost of the job. Once all the paperwork is complete, a billing account has been set up and the advance received, the job will be held until someone from System Design can start working on your project.

Design and Construction Cost

DMEA will handle requests for new construction services in the order the requests are received, but will also consider applicant’s/member’s circumstances and needs when establishing its design and construction schedules. Once the job progresses to the top of the schedule, a System Designer will contact the applicant/member for an onsite appointment. During this appointment the System Designer will go over a check-off list, proposed line routes, equipment locations, permits, right-of-way easements and estimated costs.

Typical DMEA specification drawing details and Colorado State Electrical Inspection information are available on pages 9-18. When complete project information is obtained and required documents are completed, the System Designer will design the job and determine the final cost estimate. All costs shall be determined by DMEA’s current construction costs, and will include all costs necessary for the extension of facilities including design expenses, right-of-way investigation, and any necessary licenses and permits. Any changes to the design or additional trips to the site may result in additional expense to the applicant/member.

Once payment is received, the cost of construction will be good for 12 months. DMEA reserves the right to update the cost of construction if the work has not been completed within 12 months, and/or cancel the job and refund the unused portion.

Scheduling and Site Readiness

Once the job has been designed and paid for, the job will be forwarded to the Line Crew Foreman or Serviceman. At that time the Foreman or Serviceman will be in charge of scheduling the job. **DMEA assumes no liability for unforeseen factors that delay the project completion date.**

DMEA will design, construct, own, operate, and maintain all facilities, including meters on DMEA's side of the point of attachment for all classes of service.

Temporary meters are allowed during the period of construction or 90 days, with the intent to install a permanent meter within 12 months. If a permanent service has not been established in the first 12 month period, DMEA will automatically bill the customer's account for the cost of the temporary meter and amp fee. DMEA may also notify the State Electrical Inspector that the meter is still temporary.

Before New Service Can Be Energized

The **Colorado State Electrical Inspector** must inspect and approve the member's meter base before it can be connected for service by DMEA (refer to Colorado State Electrical Inspections on page 12):

The member-furnished trench must be provided in accordance with DMEA's trench specifications (see Underground Service Installations section). In no circumstance will DMEA be responsible for costs associated with trenches including dirt or rock work.

Extra Trip Fee for Construction Delay

*DMEA reserves the right to assess a flat charge to any member causing a construction delay for DMEA construction crews. A construction delay is any trip to the job site made by a construction crew where the scheduled work could not be completed by the construction crew because conditions at the site were different than what was represented by the member when the appointment was scheduled by the member. **A minimum charge of \$100 per occurrence may be assessed.***

CALL BEFORE YOU DIG – COLORADO 811

For all underground utility line locates contact the Utility Notification Center of Colorado (UNCC) by dialing **811** at least three business days prior to starting excavation.

DMEA or DMEA sub-contractors will not be responsible for damage to underground facilities that are member-owned and have not been accurately located; including, but not limited to septic tank(s), sewer line(s), irrigation pipe(s), sprinkler(s), leach field(s) or any other facilities.

Right-of-Way Easements and Access

If an easement is required for the construction of new power lines, it will need to be obtained prior to installation of the requested service. In the event DMEA has to cross property other than that of the member requesting the service, the requesting member is responsible for obtaining all private easements needed. A platted and dedicated front lot easement will be provided for utilities in all subdivisions. If the power line is along a county road, DMEA will have an easement of 15 feet. All other easements will be 25 feet (12.5 feet from the center of the installed utility line).

Plant Investment Fee

A Plant Investment Fee of \$1.50 per amp will be added to the cost of any new or upgraded residential or commercial service to fund general improvements to DMEA's electric system.

- Residential facilities requiring a 200 amp service will have a fee of \$300, while a 400 amp service will have a fee of \$600.
- Commercial facilities requiring a 600 amp three-phase service will pay a fee of \$2,700 (((600 amps x 3 phases) = 1,800 amps) x \$1.50 per amp = \$2,700).

Special Considerations for Motor Loads

- Motor loads with variable frequency drives may require: upgrading transformer size (pole class may have to increase), decreasing transformer impedance, increasing service wire size, decreasing service wire length and/or harmonic filters to reduce Total Harmonic Current Distortion at the member's meter (per IEEE Standard 519). These changes will be at the member's expense.
- DMEA strongly recommends electrical protection on three-phase motors. This protection should include: loss-of-phase, reverse phasing and low-voltage protection (including low-voltage protection for single-phase motors). DMEA will not assume responsibility for damages related to a member's lack of protection.
- Motor loads should be compensated for their reactive power usage by installation of shunt capacitors.
- New installed motors or any other load shall cause less than 3% voltage flicker (per IEEE Standard 141) at the member's meter.
- Installation and/or operation of **single-phase motors greater than 10 HP** are not allowed without written approval by DMEA.
- Installation and/or operation of **three-phase motors greater than 30 HP** are not allowed without installation of an appropriate technique of limiting the motor starting current to be approved in writing by DMEA.

Load Balance

- New **single-phase loads in excess of 100 kVA** will only be allowed with written approval by DMEA; lower limits may apply in certain areas.
- Member's load shall be arranged:
 - Balanced, between the 120-volt legs, with one leg not exceeding 60% of the connected load.

- Between the three phases on a three-phase service to not exceed 10% unbalance (Percent Unbalance = maximum phase current deviation from the average current times 100 divided by the average of the three phase currents).
- Members accepting three-phase service from an open-wye, open-delta transformer bank shall sign a liability waiver form indicating the member's acceptance of potential hazards due to voltage unbalance.

Short Circuit Current, Fault Current and Arc Flash

- For purposes in this Construction Handbook, short circuit current and fault current are synonymous. DMEA will provide **infinite-bus** short circuit current based on the service transformer nameplate data upon request. However, the member is responsible to size and maintain member-owned equipment able to accommodate the actual short circuit current at its location. This means a larger capacity or a lower impedance transformer capable of higher short circuit current may be installed in the future requiring member installation of a current-limiting fuse(s), or member replacement of member-owned equipment with higher short circuit current ratings.
- Due to the possibility of electric shock and/or arc flash, DMEA strongly recommends when members are performing maintenance work on or near exposed electrical equipment that their electric system be de-energized, or be worked on by a qualified licensed electrician using appropriate personal protective equipment.

ELECTRICAL SAFETY CODE CLEARANCES

The National Electrical Safety Code (NESC) is the standard used in the design, construction, maintenance, and operation of electric transmission and distribution systems. DMEA reserves the right to terminate service without prior notice when a hazardous condition exists.

A specified clearance will be maintained over state highways, all streets, county roads, driveways and residential properties. The National Electric Safety Code and the Colorado Department of Transportation or the authority having jurisdiction regulates the clearance heights over roads, streets and other areas.

To comply with NESC requirements, easement and right-of-way (ROW) finished grades cannot be changed more than six inches by excavation or filling without prior approval of all utility companies located within the ROW. Buildings or other permanent structures shall not be constructed within utility easements without written consent from DMEA. **If the member does build within a utility easement, the line will be moved at the member's expense.** Landscaping within an easement is permissible, but shall not violate DMEA's Vegetation Management Policy.

Clearances of Secondary Wires, Conductors and Cables

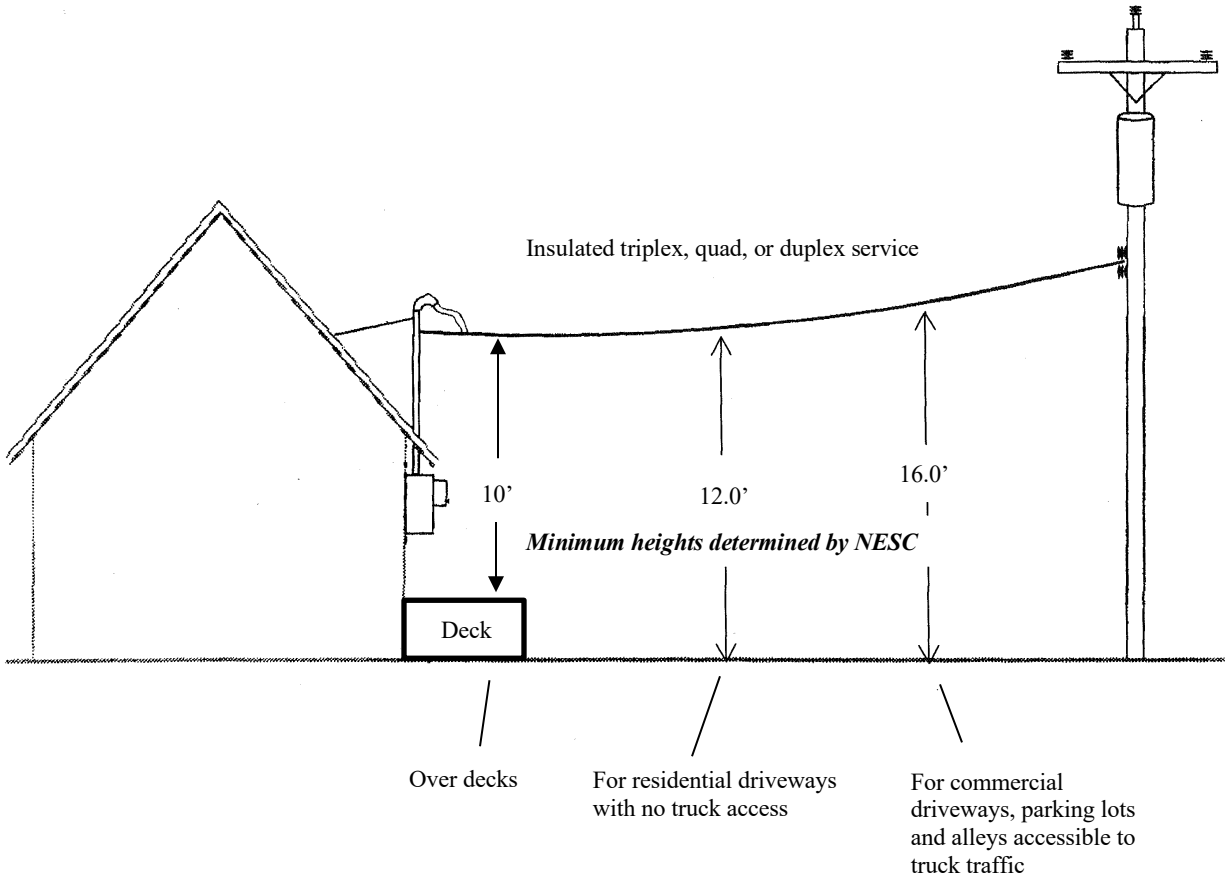

VEGETATION MANAGEMENT

Trees are a major contributor to electric service interruptions nationwide. Trees cause outages in two ways: mechanical and electrical. Mechanical damage refers to entire trees or portions of trees falling and physically damaging facilities (knocking down wires, poles, etc.). Because trees can be conductive, electrical outages can also occur. These interruptions are caused when a portion of a tree becomes a short circuit path for electricity to flow, causing a protective device to operate and stop the flow of electricity. Vegetation must therefore be maintained an adequate distance from the conductors in an attempt to prevent interruptions of electric service.

Factors to consider in determining the extent of vegetation management required include, but are not limited to: line voltage class, species growth rates and failure characteristics, right-of-way limitations, the vegetation's location in relation to the conductors, the potential combined movement of vegetation and conductors during routine winds, sagging of conductors due to elevated temperatures or icing, and the probability to reach energized lines within a five-year growth cycle.

Vegetation management is a data-driven, progressive system of information gathering utilized to best plan and complete work. It involves the use of various types of vegetation management treatments including removing, pruning and mowing of vegetation. **Emphasis shall be placed on removing trees, in or out of the right-of-way, whenever possible.**

DMEA Vegetation Management Guidelines to consider prior to construction and landscaping:

- Trees, shrubs or bushes shall not be planted directly above underground utility lines. Before digging to plant anything, it is the member's responsibility to call 811 to locate the underground utility lines.
- All trees, shrubs or bushes must remain at least five feet on either side of locates and flags designating underground utility lines.
- The member assumes responsibility for all trees, shrubs or bushes that are planted in the utility easement. In the event that DMEA has to excavate any utilities in the easement or maintain any equipment, DMEA will not replace or be responsible for any trees, shrubs or bushes that need to be removed.
- Trees, shrubs or bushes that can grow taller than 15 feet, at maturity, shall not be planted under or near overhead utility lines.
- *No tree, part of a tree, or shrub should ever get within 15 feet of a utility line, therefore careful consideration, of the size of the tree at maturity, is important during planting.*
- Trees growing near DMEA distribution and transmission lines will be removed or trimmed to maintain a minimum of a five year growth cycle.
- A DMEA field representative will ensure that all tree removals and/or trimming is complete prior to constructing a job. No lines will be energized until clearances are met.
- The member always has the option of underground construction (at the member's expense) if the necessary overhead right-of-way clearances cannot be made.

Please contact **DMEA's Operations Manager at (970) 249-4572** if you have any vegetation management questions.

SPECIFICATIONS FOR METER INSTALLATIONS

General

DMEA will make permanent connections between the member's electric service wiring and DMEA's system. Unauthorized connections are not permitted. DMEA will furnish, maintain and retain ownership of all meters and instrument transformers. Terminations will only be allowed on the exterior of the facility being metered. No DMEA termination will be inside or enter the member's facility. DMEA is not responsible for member owned facilities, such as, but not limited to meter bases, loops, and/ or panels.

Removal, relocation or performing of any work on an electric meter without DMEA's permission is prohibited. Tampering with DMEA's metering equipment, making an unmetered connection, or making an unauthorized reconnection to DMEA's system is prohibited and the offending member will be subject to disconnection and/or fines.

Re-energizing any disconnected meter located on a DMEA pole will require the member to relocate the meter/panel to a pedestal or structure located at least 4' away from the pole. DMEA will, at no cost to the member, provide the pole u-guard and up to 50' of service wire to assist in moving the meter/panel. The member will be responsible for all other costs including any necessary trenching and additional wire.

Electric Meter Locations

- Customer to supply all meter panels and meter bases, 200 amp minimum.
- Customer to provide slip joints and conduit as required (2" for 200 Amp, 3" for 400 Amp).
- Meter panels will be located either: 1) at the lot-line, 2) on the front of the house, 3) within the front third of the front corner of the house, or 4) the street side and Always Accessible and Safe.
- If a member-owned meter base/loop (contingent upon DMEA approval) is located on a DMEA secondary pole, it will be at the member's expense to relocate their facilities to a meter pedestal in the event the pole is damaged or needs to be replaced.
- Meters will not be located in any area considered hazardous, flammable or where reading, testing or servicing of the meter may become impractical, (i.e. behind fences, enclosures, or shrubs, under decks, around dangerous animals, or inside structures or enclosures). ***If meters are not accessible, they may be moved by DMEA at the member's expense.***
- Meters will be located no less than 3'6" and no more than 5'6" above final grade.
- No steps or stairways will be permitted as access to meters.
- In no circumstance will a new meter be installed on a DMEA power pole.
- **GAS Regulators will be located at least 4' away from Electric meters.**
- Meters are owned, installed and maintained by DMEA.
- Multiple meter sockets must each be clearly marked with **permanent metal scribed tags** (at the member's expense) to identify correct addresses. Correct meter labels and appropriate addresses shall be verified by member's electrician before permanent meters will be installed.
- DMEA will not attach its supply wires to more than one meter on a single structure, unless the meters are grouped together in such a manner that all are energized through the same transformer (Electric Service Regulations III.O).

Self-Contained Metering Installations

As of 5-17-17, re-energizing rewired, altered, repaired or disconnected single-phase or three-phase self-contained 480 V services require State Electrical Inspector approved installation of a UL-approved single-phase or three-phase (as appropriate) non-fuseable loadbreak disconnect switch lockable and operable by DMEA load-side of the meter (at the member's expense).

Self-contained metering for either single-phase or three-phase is available for 240 V and below.

All new single-phase 320 Amp installations and all new three-phase 200 Amp, self-contained meter installations shall have a UL-approved non-fuseable loadbreak disconnect switch lockable and operable by DMEA installed load-side of the meter (at the member's expense).

For single-phase self-contained metering installations, the member provides and maintains the meter socket, and DMEA provides (at the member's expense) and maintains the meter.

For single-phase services requiring power at 120/240 having a service rating of 200 amps or less, a properly sized self-contained UL approved 4 jaw meter socket will be installed. A 120/208 single-phase self-contained network meter must be provided with a 5 terminal socket with the 5th terminal in the 6 o'clock position and a UL-listed (Landis + Gyr or Square D) **manual lever bypass switch**.

The member provides and maintains all 3-phase self-contained meter sockets including multiple meter stacks. Three-phase self-contained meter sockets with a **manual lever bypass switch** will be UL-listed (Landis + Gyr or Square D). All other sockets must receive prior approval before the metering equipment is ordered. A sample of the meter socket will be sent, including job name and number, to DMEA, attention: Equipment Tech Foreman.

Any **commercial** account that requires a self-contained meter, including network meters, must have a **manual lever bypass switch**. Self-contained meter sockets with a manual lever bypass switch will be UL-Listed (Landis + Gyr or Square D). All other sockets must receive prior approval before the metering equipment is ordered. A sample of the meter socket will be sent, including job name and number, to DMEA, attention: Equipment Tech Foreman.

For single-phase services with a capacity greater than 200 amps and including, but not exceeding 400 amps, a 400 amp (320 amp continuous rating) meter socket will be installed with a minimum service wire size of 350 MCM, a **manual lever bypass switch**, locking jaws and a disconnect or disconnects that will de-energize the entire panel. Disconnects must be accessible to DMEA personnel. The continuous load for these services shall not exceed 320 amps. Meter bases with a continuous rating of 400 amps or sockets for bolt-in meters are not acceptable.

In the event of a failure, the member or a licensed electrician will replace the meter socket and wire within the service mast. Inspection will be required by the State Electrical Inspector if wire within service mast has to be replaced. DMEA will not be responsible for any code violations found outside the scope of DMEA work.

Instrument Transformer (CT) Metering Installations

- Three-phase services greater than 200 A or greater than 240 V phase-to-phase shall be CT-metered.
- Single-phase 120/240 V services greater than 400 A shall be CT-metered.
- DMEA provides and maintains (at the member's expense,) all single-phase and three-phase CT-metered meters and meter sockets except for multiple meter stacks.
- CT's will be located in a CT cabinet furnished by the member, unless otherwise approved by the DMEA Engineering Department. For CT cabinets 1200 amps or less, the customer will provide a UL-Listed bar-mounted CT cabinet. For CT cabinets more than 1200 amps (which require a switchgear cabinet) the metering will be approved by the DMEA Engineering Department.
- The point of demarcation will be the member furnished bar-mounted CT cabinet or weatherhead. The cabinet must meet minimum NEC size requirements.
- For terminations in the bar-mounted CT cabinet, the member will provide the approved connectors and terminate all wires within the box.
- DMEA will provide conduit and wire and will pull wire to the CT cabinet.
- Members will not have access to DMEA's transformer, only DMEA will have this access. DMEA will make all connections in the transformer.
- Terminations will only be allowed on the exterior of the facility being metered. No DMEA termination will enter the member's facility.
- CT meter sockets will not be mounted on switchgear doors or cabinets.
- UL-approved single-phase or three-phase (as appropriate) non-fuseable loadbreak disconnect switch lockable and operable by DMEA installed load-side of the metering.
- Metering equipment must be located outside the member's facility and accessible at all times by DMEA personnel.

Single Member or Multiple Members – CT Metering

For single member or multiple member services, metering CT's must be installed in a bar-mounted CT cabinet mounted on the member's facility and furnished by the member. For CT cabinets 1200 amps or less, the member will provide a UL-listed bar-mounted CT cabinet. For CT cabinets more than 1200 amps, the CT cabinet specification must be preapproved by the DMEA Engineering Department. The meter will be mounted next to the CT cabinet at the member's facility. The point of demarcation will be the member furnished bar-mounted CT cabinet or weatherhead. DMEA will supply and install all wire and conduit (at the member's expense) to the member furnished connectors in the CT cabinet. DMEA's System Designer will determine the number and size of wire and conduit to be installed. The service entrance knockouts in the CT cabinet is the responsibility of the member and location of the knockouts will be specified by DMEA. DMEA will terminate source-side wires to the top-side of the CT cabinet, and the member will terminate to the lower CT cabinet terminals.

A DMEA Operations or Engineering Manager must approve any exceptions to the above in writing.

COLORADO STATE ELECTRICAL INSPECTIONS

A service entrance (meter socket on building or meter pedestal) is required to be inspected by the **State of Colorado Electrical Inspector** before final connection can be made. State law (Title 12 Article 23-116 C.R.S. 1973) states that no utility shall provide service to any person required to have electrical inspection without proof of final approval. State Inspections are required only on the member side of the meter.

The member or member's Electrical Contractor must obtain an electrical permit from the State of Colorado Department of Regulatory Affairs (DORA), prior to starting work. Apply for an electrical permit at:

<https://dpo.colorado.gov/ElectricalPlumbing/Permits>

It is the responsibility of the member to contact the inspector when the work is ready for inspection.

The phone numbers for the **State Electrical Inspectors** are:

Montrose County: 303-894-2073 Carolyn Felix

Delta County: 303-894-2429 Patrick Proctor

State Electrical Inspector Supervisor: 303-869-3455

When the work is approved, the inspector will tag the meter base with a green-, yellow- or red-lettered sticker. If the work is not satisfactory, a red sticker will be placed on the meter panel and must remain there until corrections are made and it is re-inspected. Once the State Electrical Inspector has given final approval of the electrical work, it is the member's responsibility to contact the DMEA System Design Customer Service Representative with the permit number to schedule the work at: 970-240-1256.

Electricians needing Short Circuit Currents for Commercial Installations (per NEC 110-24) to pass State Electric Inspections, should allow at least three business days to obtain this information from a System Designer at DMEA.

Inactive Service Inspection: After 6 months of a service being disconnected or de-energized, the property owner must obtain an electrical inspection by the Colorado State Electrical Inspector to verify a safe system still exists. Upon DMEA-approved evidence of inspection, DMEA will connect and energize the system.

WORKING CLEARANCES FROM ELECTRIC METER

(Refer to the State of Colorado Electrical Inspector or an electrician for more details)

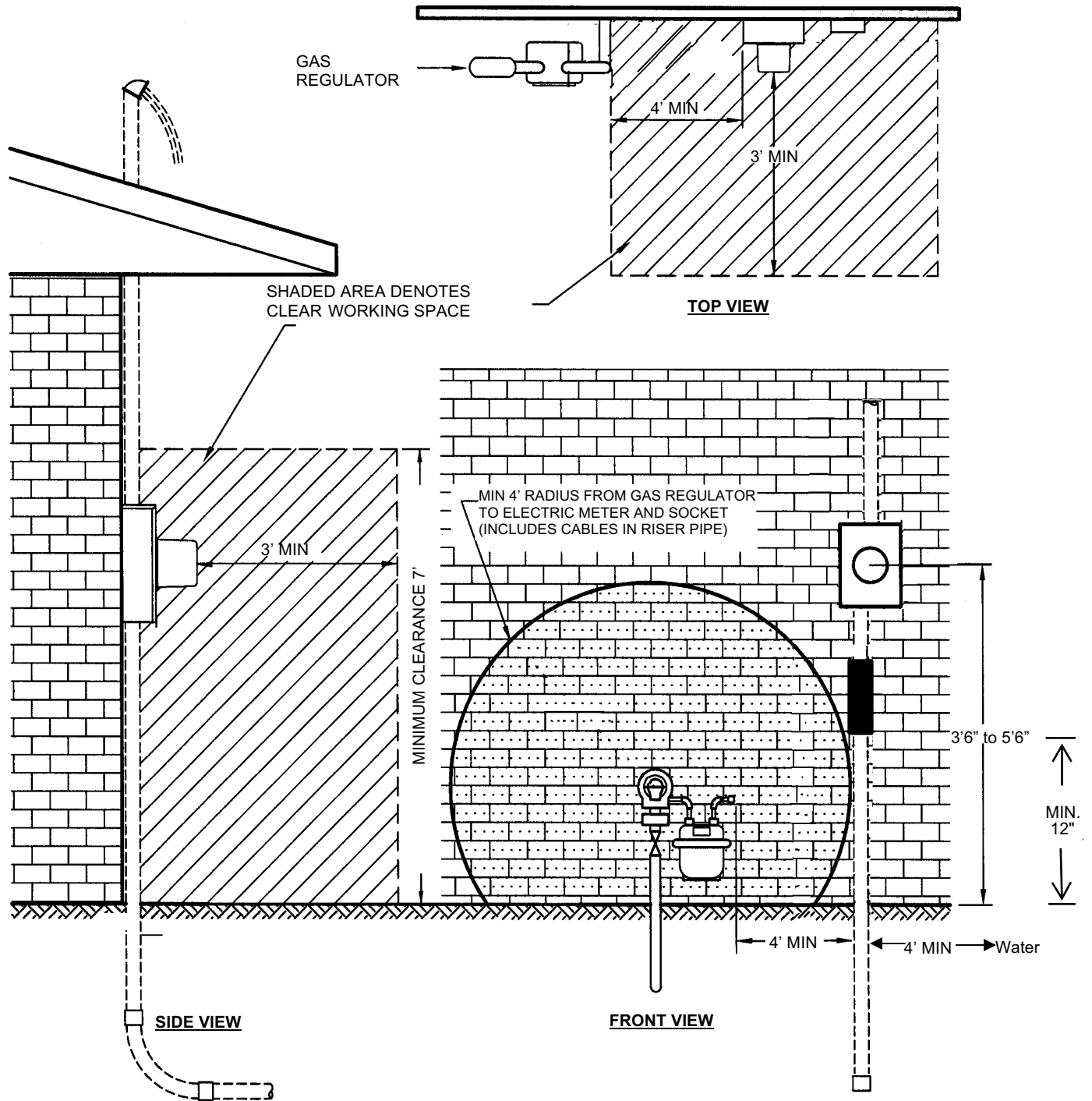

UNDERGROUND SERVICE INSTALLATIONS

METER BASE ON HOUSE OR BUILDING

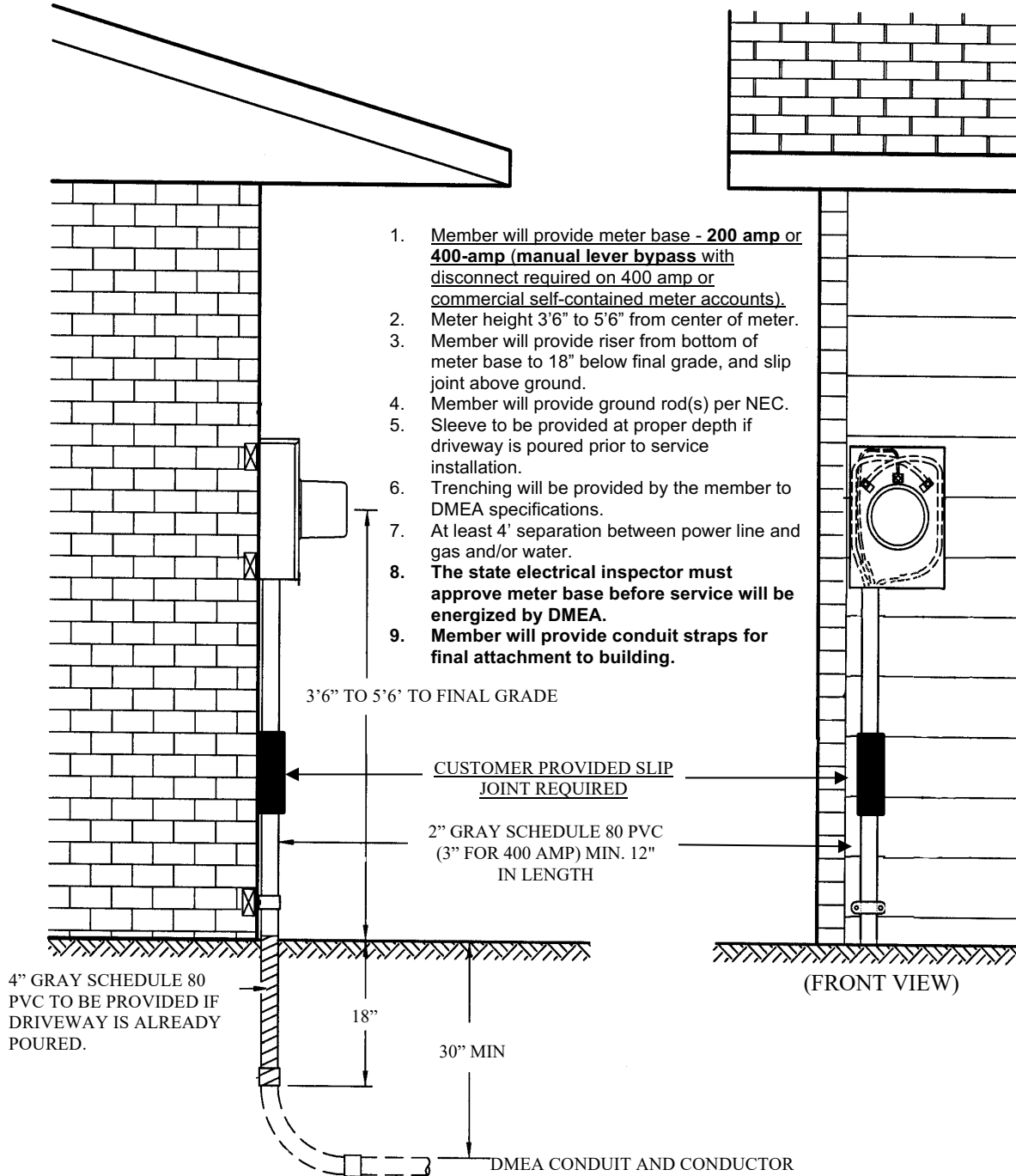

UNDERGROUND SERVICE INSTALLATIONS

PERMANENT METER PEDESTAL

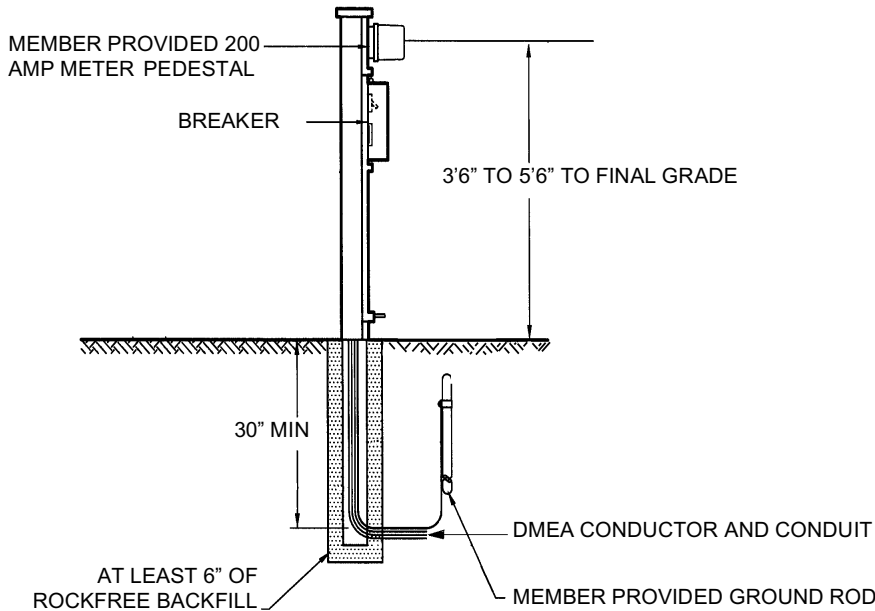

NOTES:

1. Member will provide meter base/pedestal. 200 amp (400-amp breaker) is required at meter pedestal on all installations. Manual lever bypass with disconnect is required on 400 amp or commercial self-contained meter accounts.
2. Meter height 3'6" to 5'6" from center of meter.
3. Member will provide riser from bottom of meter Base to 18" below final grade, and slip joint above ground.
4. Member will provide ground rod(s) per NEC.
5. Sleeve to be provided at proper depth if driveway is poured prior to service installation.
6. Trenching will be provided by the member to DMEA specifications.
7. At least 4' separation between power line and gas and/or water.
8. **The state electrical inspector must approve meter base before service will be energized by DMEA.**

TEMPORARY METER PEDESTAL

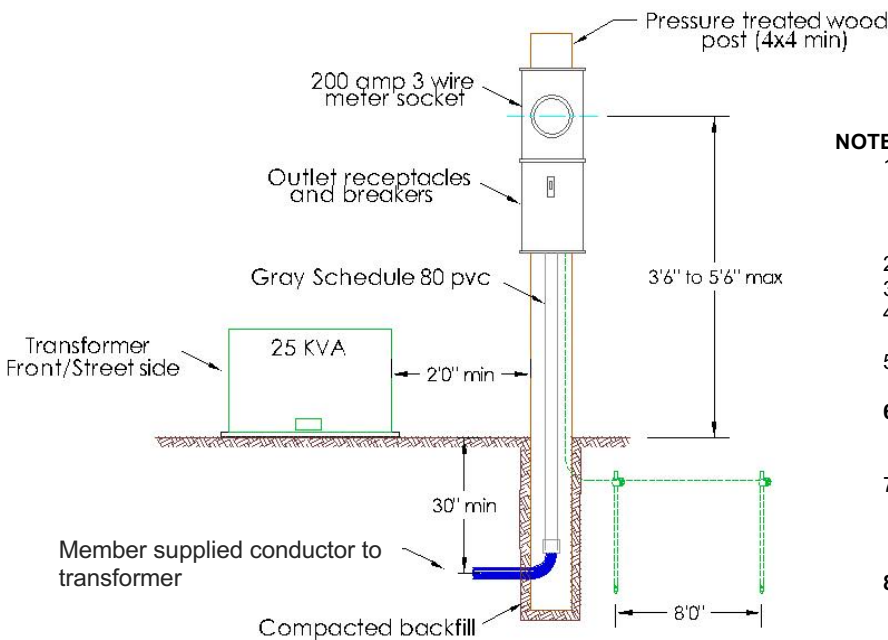

NOTES:

1. Member will provide the whole temporary meter pedestal (post, meter socket, breakers, conduit, outlets, and enough wire to reach from temporary to the inside of the transformer).
2. Meter height 3'6" to 5'6" from center of meter.
3. Member will provide ground rod(s) per NEC
4. Trenching will be provided by the member to DMEA specifications.
5. At least 4' separation between power line and gas and/or water.
6. **The state electrical inspector must approve temporary meter pedestal before service will be energized by DMEA.**
7. Temporary meter pedestal will be set no less than 2' from transformer and no more than 10' unless pre-approved by a DMEA System Designer, Line Crew Foreman, or Serviceman.
8. **200 Amp (or 400 amp) breaker is required at meter pedestal on all installations.**

UNDERGROUND SERVICE INSTALLATIONS

Trenching Specifications (Primary and Secondary)

- Do not dig trench prior to being contacted by DMEA operations for scheduling.
- Conduit or secondary underground service conductor will not be installed to member's facility until an inspected and approved meter base is in place. All conduit and conductor will be installed by DMEA.
- Member must provide a clean, rock-free flat-bottom trench with a 6" bedding of rock-free dirt or sand. Excessive bends and curves (totaling 360 degrees total) in the trench are not allowed.
- Primary trenches will be 48" deep with a 6" bedding of rock-free dirt or sand. **The conductor must be at least 42" below final grade after installation.**
- Secondary trenches will be 36" deep with a 6" bedding of rock-free dirt or sand. **The top of the conduit must be at least 30" below final grade after installation.**
- Secondary trenches should be opened to the front of the existing transformer, and also to the fiber vault/pedestal when applicable
- Depths specified are to finished grade.
- It is the responsibility of the member to make sure the trenches are in the allotted easements on their property.
- DMEA employees will not enter trenches that do not meet OSHA's excavation standards, 29 CFR 1910.269. (Spoils must be a minimum of 2 feet back from the trench).
- Gas, sewer and water lines will not be included in an electrical trench. There shall be at least four feet of horizontal separation from DMEA conductor where other trenches are in the same proximity.
- When gas or water lines cross in the trench with electric lines, there must be at least one foot of vertical separation.
- Conductor will not be energized until backfill is properly completed.
- DMEA will supply ELECTRIC CAUTION TAPE and asks the member to install it 12" above conductor when backfilling the trench.
- **Electric service must be installed in a separate trench from water and/or gas. No joint use of trenches will be allowed with water and/or gas.**

Primary Trench

Secondary Trench

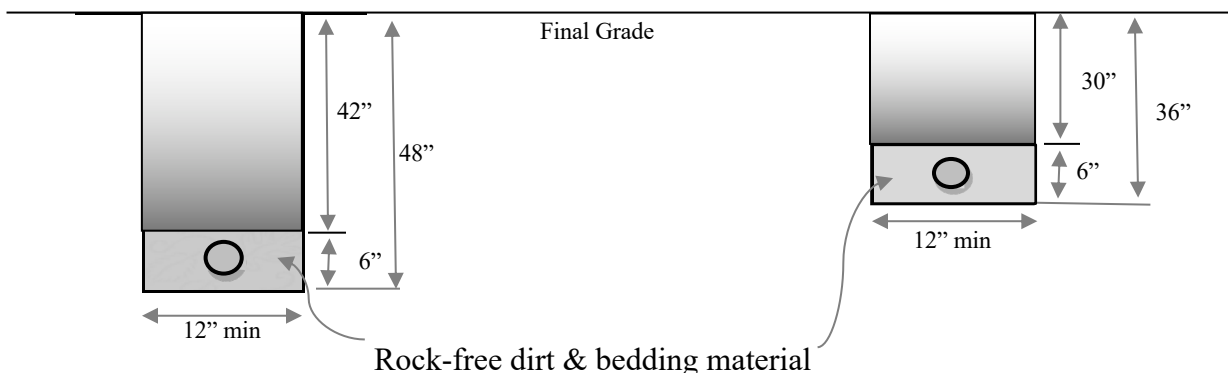

Joint Use Trench

Members and developers requiring a joint use trench where telephone and television cable are within the electric trench are solely responsible for all coordination between the included utilities. All utilities requesting joint-use trenches must be designed and ready to be installed at the time the DMEA facilities are scheduled for construction. A minimum 1-foot separation is required between electrical and all other services that share the trench.

Although non-conductive utilities such as phone and television cables are allowed in DMEA trenches, for the safety of personnel, DMEA does not allow customer-owned installations such as control cables, wiring or 120/240 V secondary service wires. Any customer whose trench does not meet the above specifications and causes the Line Crew or Serviceman an extra trip will be subject to an additional fee.

OVERHEAD SERVICE INSTALLATIONS

OVERHEAD TEMPORARY SERVICE

NOTES:

1. Member will provide the whole temporary meter pedestal (post, meter socket, breakers, conduit, outlets, and enough wire to reach from temporary to the inside of the transformer)
2. Meter height 3'6" to 5'6" from center of meter.
3. Member will provide ground rod(s).
4. At least 4' separation between power line and gas and/or water.
5. **The state electrical inspector must inspect temporary meter pedestal before service will be energized by DMEA.**
6. Post will be set a minimum of 10' and a maximum of 15' from transformer pole unless otherwise approved by a DMEA System Designer, Line Crew Foreman, or Serviceman.
7. **NO METERS ALLOWED ON DMEA POLES**

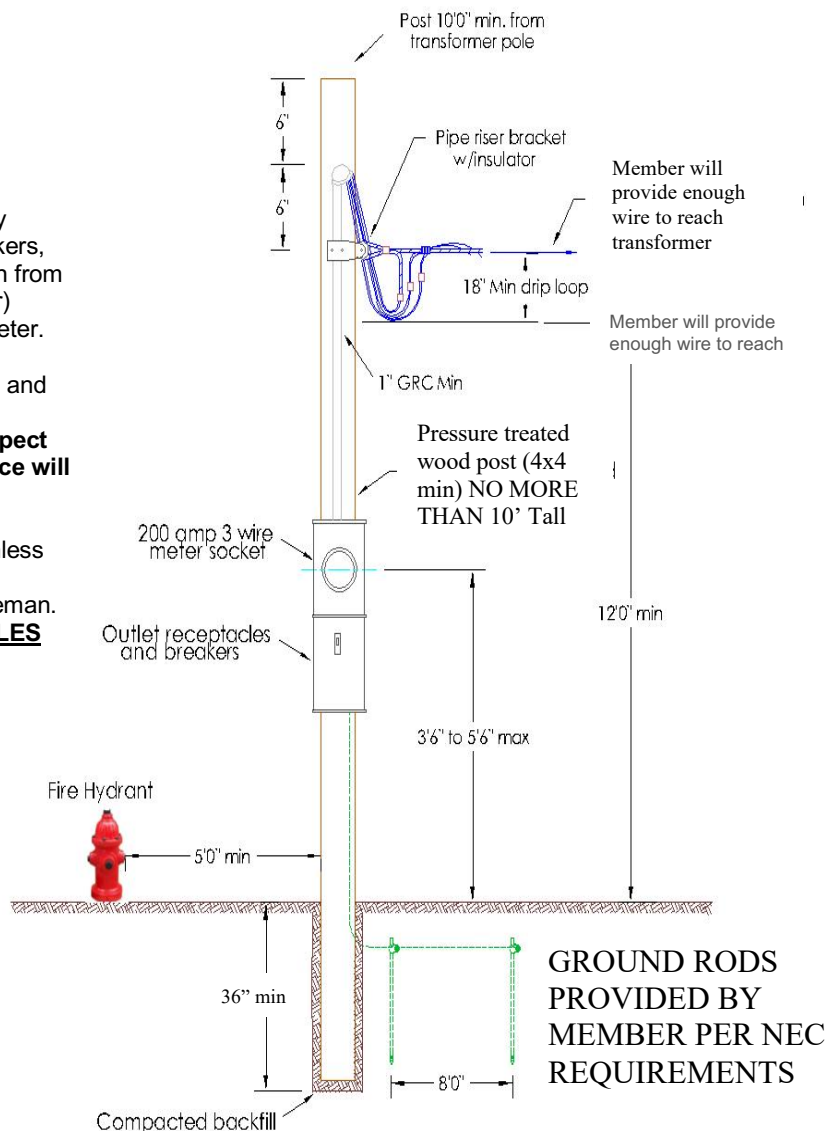

OVERHEAD SERVICE INSTALLATIONS

(Refer to the State of Colorado Electrical Inspector or an electrician for more details)

PERMANENT SERVICE - MAST ON BUILDING

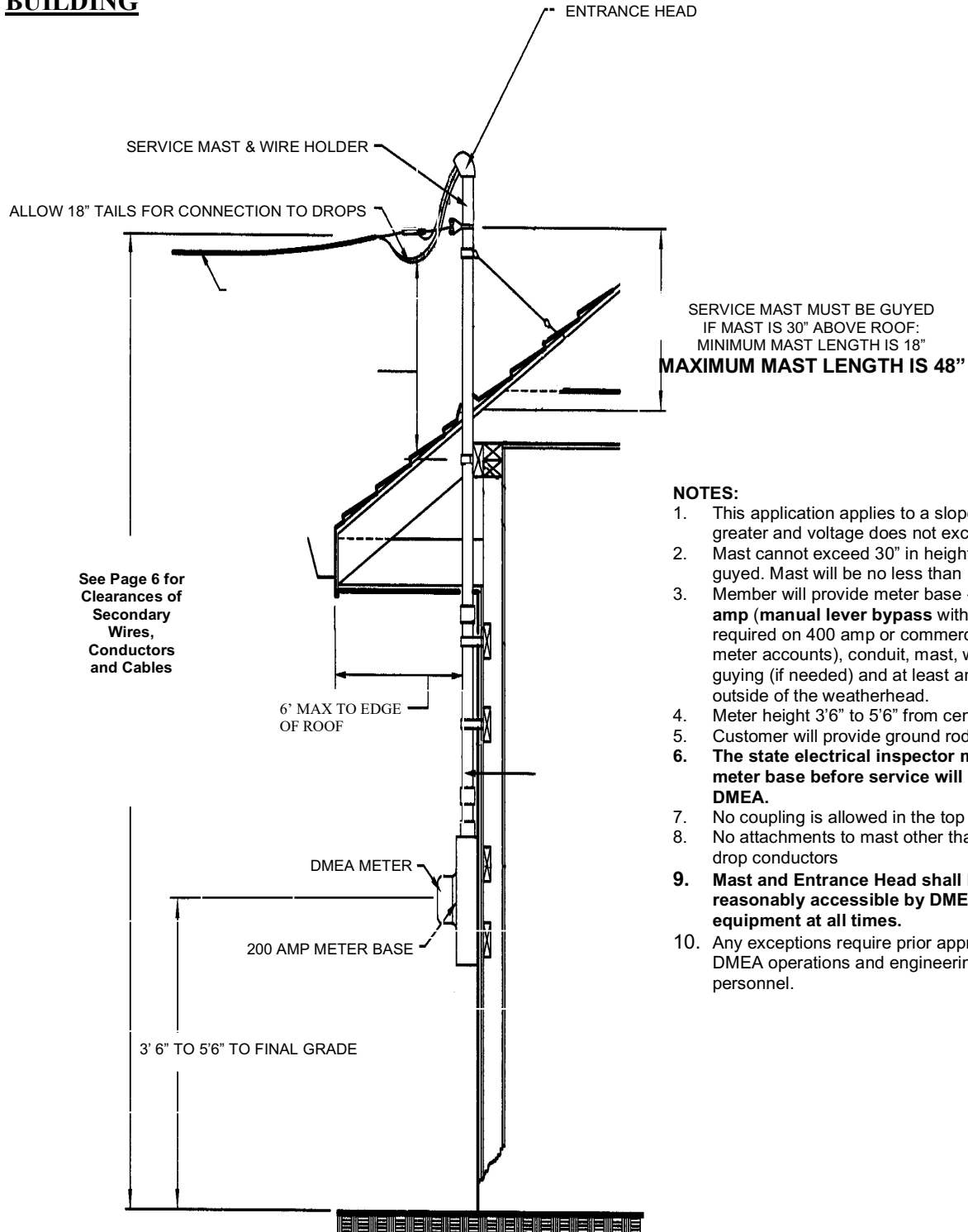

NOTES:

1. This application applies to a slope of 4" in 12" or greater and voltage does not exceed 300 volts.
2. Mast cannot exceed 30" in height without being guyed. Mast will be no less than 18".
3. Member will provide meter base - **200 amp** or **400-amp (manual lever bypass** with disconnect required on 400 amp or commercial self-contained meter accounts), conduit, mast, weatherhead, guying (if needed) and at least an 18" tale of wire outside of the weatherhead.
4. Meter height 3'6" to 5'6" from center of meter.
5. Customer will provide ground rod(s) per NEC.
6. **The state electrical inspector must approve meter base before service will be energized by DMEA.**
7. No coupling is allowed in the top 10' of the mast.
8. No attachments to mast other than power service drop conductors
9. **Mast and Entrance Head shall be safely and reasonably accessible by DMEA personnel and equipment at all times.**
10. Any exceptions require prior approval in writing by DMEA operations and engineering supervisory personnel.

DEVELOPER POLICY

Definition of a Developer

A person or an entity who develops a piece of property into more than two lots, duly approved by the governing body of the city, county, or state; with the intent being the sale of said lots for profit.

Responsibilities of the Developer

The developer shall, in advance, provide to DMEA an accurate plat of the subdivision tract duly approved by and filed with the county, city or any other entity having jurisdiction, showing the location of lots, streets, alleys, existing buildings, existing utilities, and any other underground installations or obstructions. The Developer will provide and identify permanent right-of-way easements that are compatible with DMEA's policies for design, installation, operation, and maintenance of the system including the necessary access to and from the development. **DMEA requires front lot line easements for underground electric facilities.** The Developer will provide DMEA with all pertinent load data to be used in design. **It is also the responsibility of the developer to make sure the trenches for the primary wire are in the easements. The Developer will provide permanent final grade and property corner pins prior to the installation of underground facilities and equipment.**

In order to maintain acceptable voltages and reliability, developments larger than, or with future additions will be larger than five lots will be designed with an appropriate number of phase conductors to be installed within the new development to enable balancing the feeder load. Also, the primary electrical system will be designed with the ability to feed each lot with an alternate phase or feeder connection to DMEA's primary system. Exceptions to these design standards will require written approval by DMEA's Engineering and Operations Managers.

Process for Submitting Electronic Plats for Developments and Subdivisions

DMEA requires all developers to submit to DMEA the latest and most updated (Approved Preliminary Plat) electronic version of their development **before a DMEA System Designer can meet with persons involved in planning the backbone for that development.** This information will be used to post the development to DMEA's mapping system and for use in laying out the electric backbone for that development.

There are several ways a developer can get the requested electronic plat to DMEA. All versions of the plat should be in an AutoCAD (.dwg) format. The developer can also upload the .dwg document on a USB memory stick (jump or thumb drive) and bring it to DMEA to download the information. The developer can also send an e-mail with the attached .dwg to: gisteam@dmea.com

Please inform DMEA in the manner listed above if anything in the development changes. If there is a re-plat of a subdivision, be aware that you may incur additional fees from DMEA to re-design the job, and any other costs associated with the new design.

DMEA is “Your Rural Electric CO-OP”

Board of Directors

DMEA is a private, non-profit rural electric cooperative owned and controlled by the members it serves. Individuals become members when they apply for and receive electric service. Cooperative members have an ownership interest in the cooperative through their dollar investment. At present there are seven districts and two at-large regions identified within DMEA’s service territory, each with a board member representative. *These nine directors set the policies and direction for DMEA.* For more information about the Board of Directors, contact DMEA at 1-877-OUR-DMEA, (1-877-687-3632) or visit www.dmea.com.

[Intentionally Left Blank]



Commercial Load Data Form
(Anything other than Residential)

Date: _____

Applicant Name: _____ Phone Number: _____

Service Address: _____

Electrician/Engineer: _____ Phone Number: _____

REQUESTED ELECTRICAL SERVICE BUSINESS TYPE: _____

PRIMARY

Overhead Underground

SECONDARY

Overhead Underground

SECONDARY VOLTAGE

- 120/240 1Ø3 Wire 277/480 3 Ø4 Wire Wye
120/208 3Ø4 Wire Wye

MAIN DISCONNECT (AMPERES) New Existing (if any)

SECONDARY SERVICE ENTRANCE CONDUIT

Size in. Quantity

SECONDARY SERVICE ENTRANCE CONDUCTORS

Size Quantity per phase

BUILDING SIZE

sq. ft.

HEAT and AIR CONDITIONING

Electric Heat (total) (kW)
A/C (total nameplate) (amps) (volts)
Geothermal (motor size) Quantity (volts)
(FLA - Full Load Amps)
(LRA- Locked Rotor Amps)

MOTORS (Other than Air Conditioning)

(10) hp & larger motors may require 3Ø and reduce starting current device. Please contact DMEA Engineering Department for further information.

1Ø Motor(s) 3Ø Motor(s)
hp Quantity hp Quantity
hp Quantity hp Quantity
hp Quantity hp Quantity

TOTAL LIGHTING LOAD

(kW)

ELECTRIC VEHICLE CHARGER

(kW) (volts)

COMMENTS/MISCELLANEOUS: _____

AUTHORIZED SIGNATURE DATE:
PRINT NAME

For office use only

Work Order# Account#

Staking Tech Trf kVA Number of Meters Served



Plant Trees SAFELY



It's spring and time to put the landscape plans you dreamed up this winter into action. Whether it is new trees, shrubs, a fence, or a deck, remember these safety tips before digging into your projects:

PLAN YOUR PLANTING

Before selecting and planting a tree, remember to look up to determine where the tree will be located in relation to overhead utility lines.

- ▶ Avoid planting within 20 feet of power lines. If planting is unavoidable, only plant shrubs and small trees that reach a mature height of 15 feet or less.
- ▶ Plant medium trees (under 40 feet when mature) at least 25 feet away from power lines.

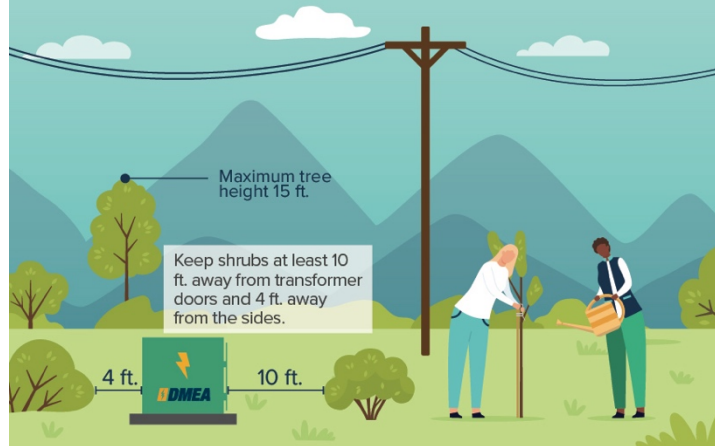

**Know what's below.
Call before you dig.**

CALL 811 BEFORE YOU DIG

If any of your projects require digging – such as holes for plants, or setting posts – remember to dial 811 first to locate underground utilities.

They will mark lines so you can safely dig and avoid turning your spring project into a disaster.

