

Connection Cabinets

FFCC-S2 Series

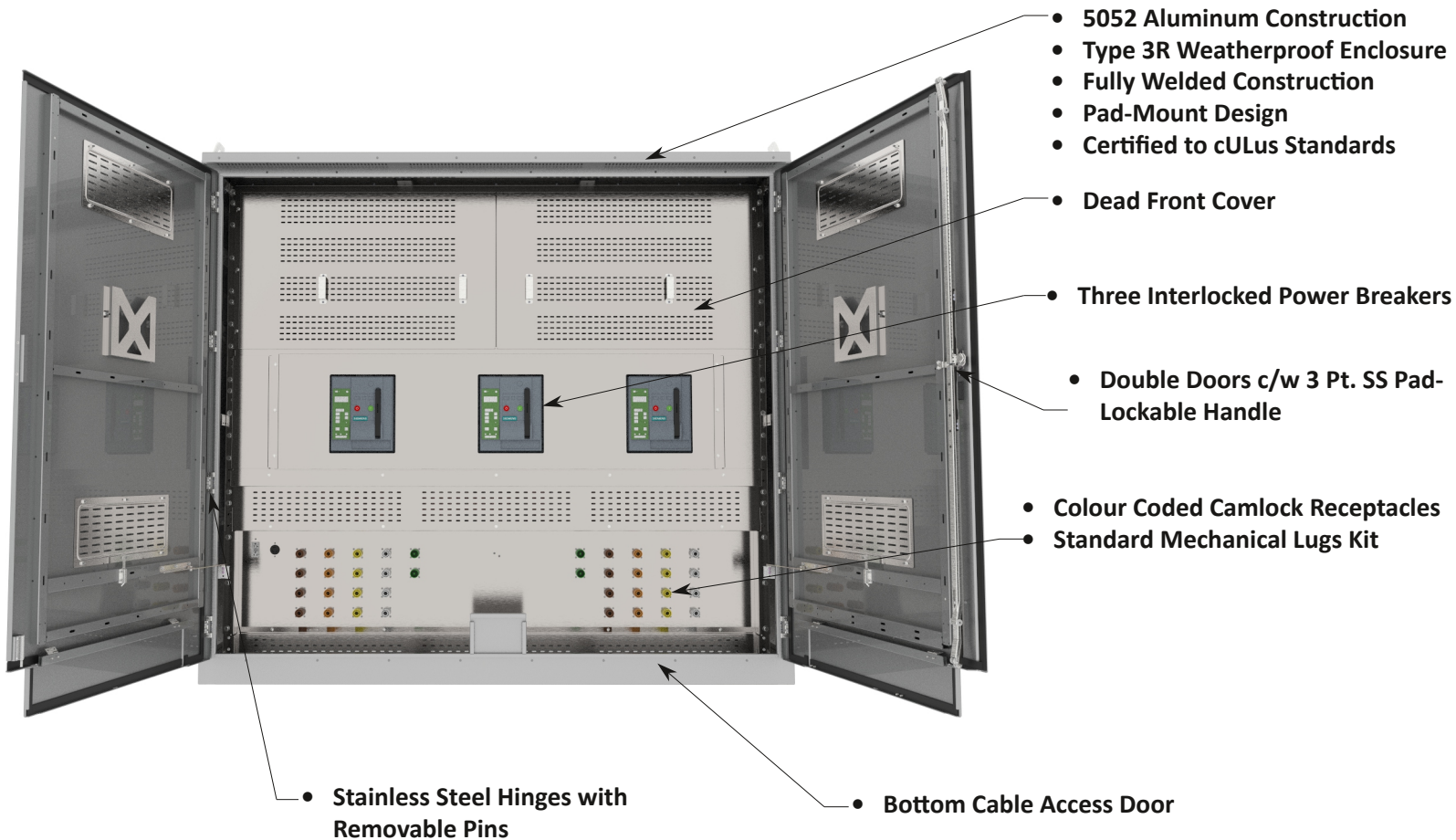

The FFCC-S2 Series 3-Way Manual Transfer Switch Connection Cabinet allows for maximum redundancy when considering load bank testing and portable generation. This unit allows for isolated load bank testing which gives the facility the ability to have a portable generator tied in at the same time. These units are equipped with colour coded camlock receptacles allowing for quick and easy load bank and portable generator connection. Units can also be assembled for service entrance applications. Assemblies are available with up to 4000A mains, certified to cULus standards and NEC 700.3F compliant.



Rev 3.0

One-Line Diagram

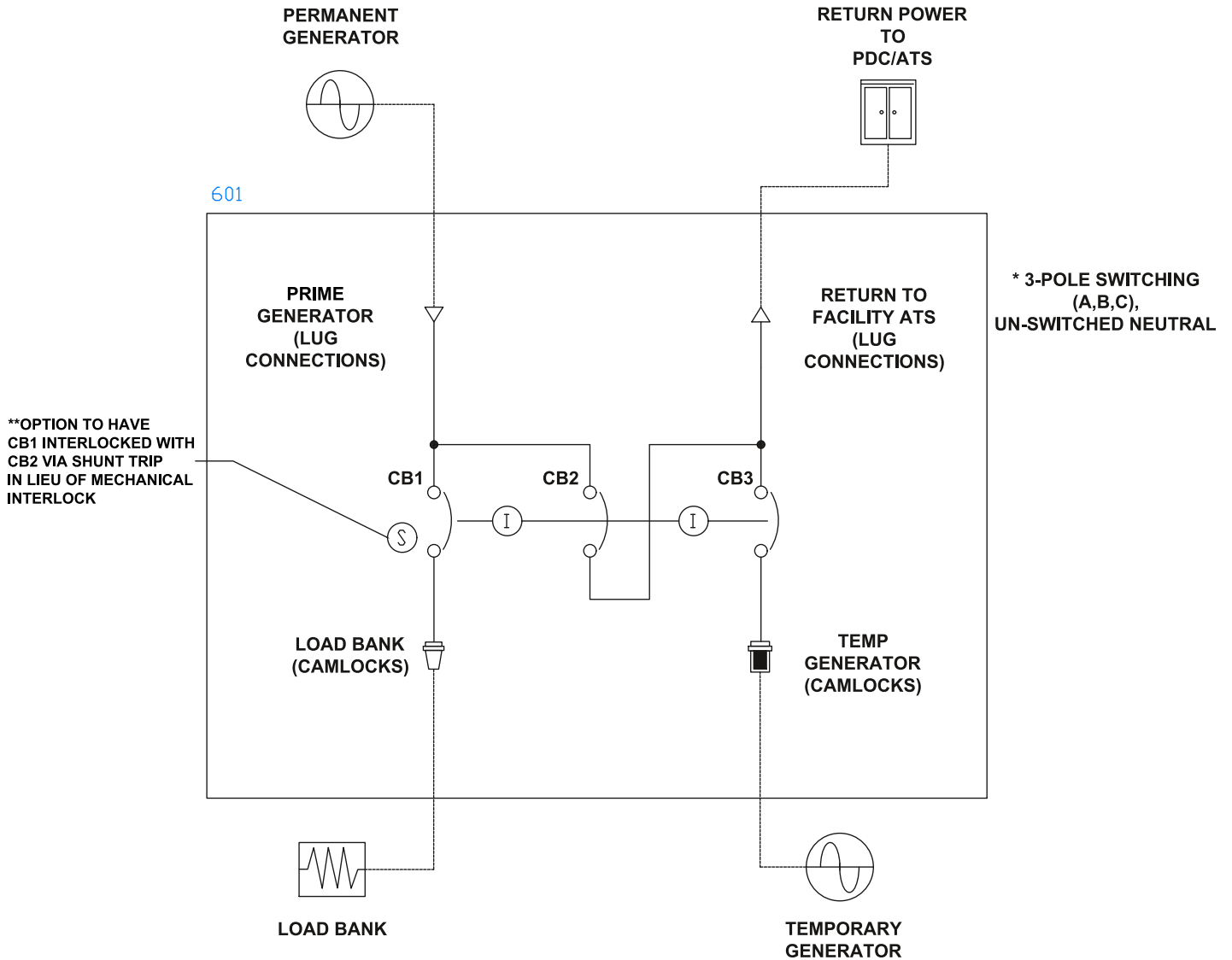

**THREE-WAY MANUAL TRANSFER SWITCH -
 EMERGENCY BACK-UP POWER NEEDS
 FULFILLED VIA ALL-IN-ONE TEMPORARY GENERATOR
 DISTRIBUTION SYSTEM.**

Connection Cabinets

FFCC-S2 Series



Product Selector

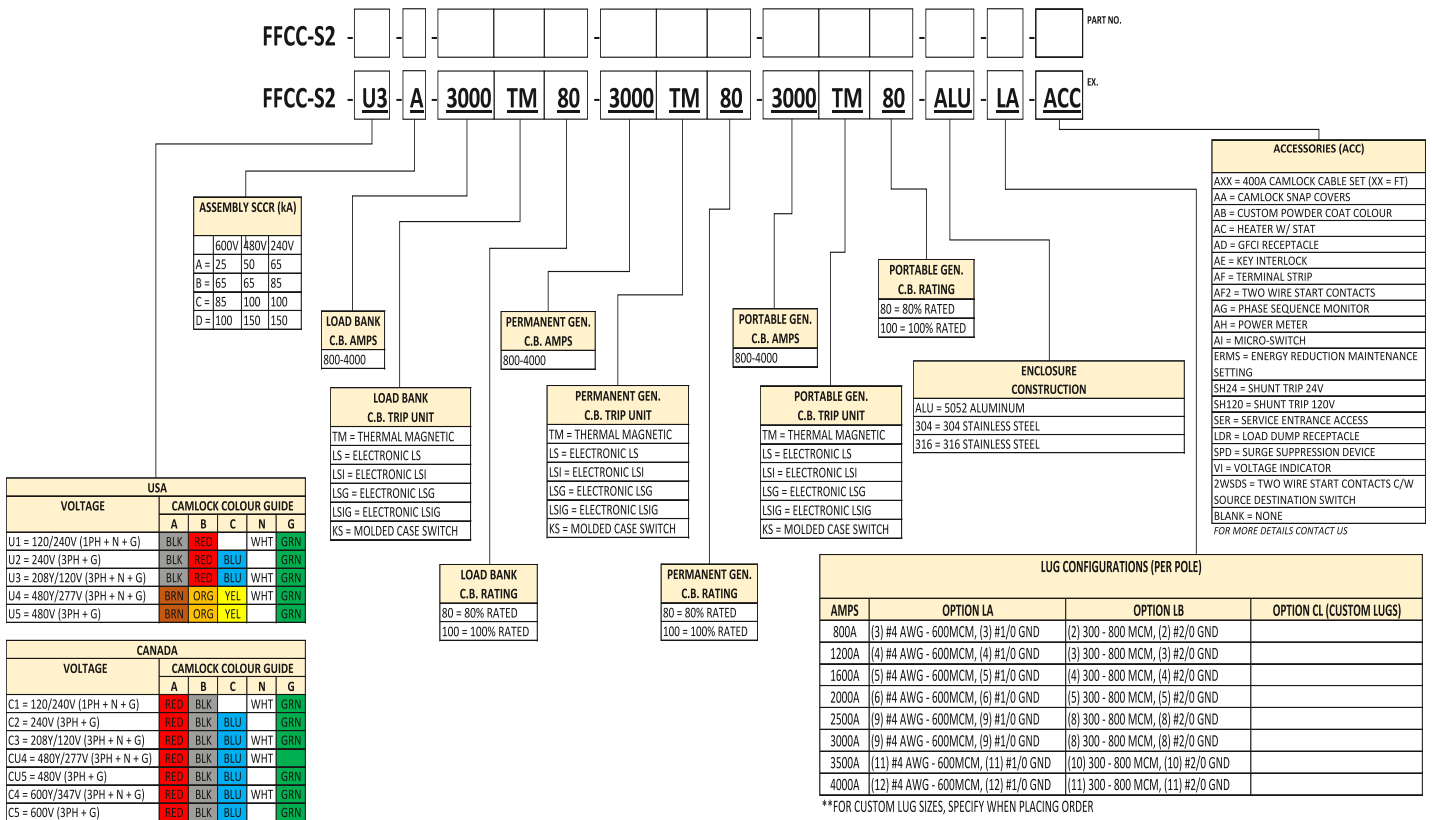

Max Ratings

- 4000A
- 600VAC

Dimensions & Est. Weights

- 90"H x 75"W x 30"D (1200A) **1520LB**
 - 90"H x 100"W x 36"D (1600A - 2500A) **2300LB**
 - 90"H x 140"W x 36"D (3000A - 4000A) **4000LB**
- 4P units, consult with factory