

Connection Cabinets

FFCC-ATS Series

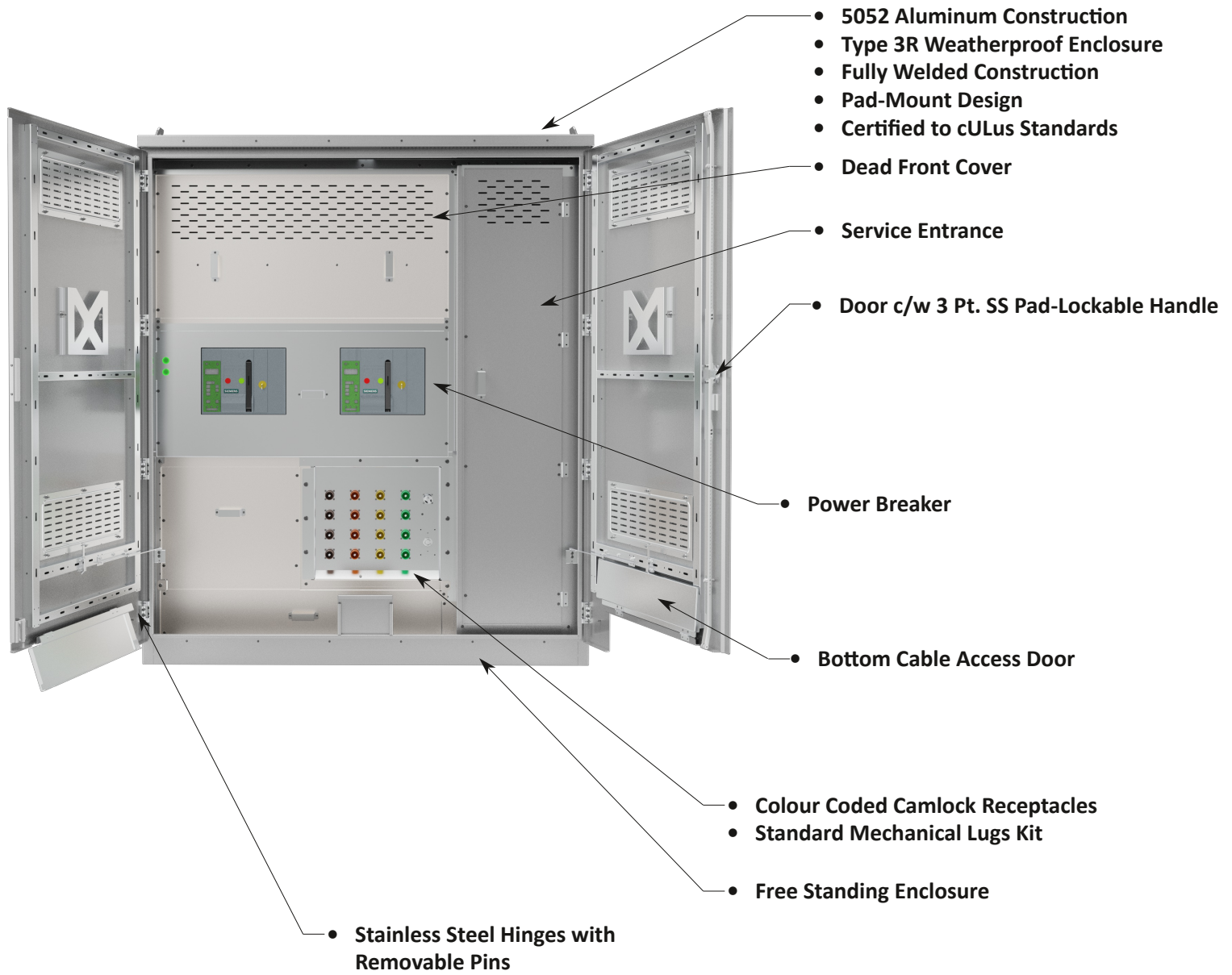

The FFCC-ATS Series Connection Cabinets offer all-in-one quick connection, which include an automatic transfer switch and a mobile generator inlet and/or load bank outlet. They can be penetrated from the top, bottom or sides to allow for facility wiring. These units are equipped with color coded camlock receptacles for easy connection and can also be assembled for service entrance applications. Assemblies are available with up to 4000A mains and are certified to cULus standards.



Rev 3.0

Connection Cabinets

FFCC-ATS Series



One-Line Diagram

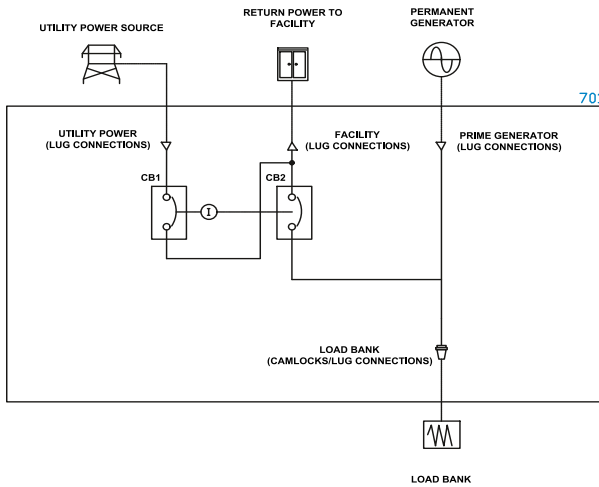

DUAL BREAKER ATS DOCKING STATION - SERVICE ENTRANCE RATED ATS WITH LOAD BANK TESTING.

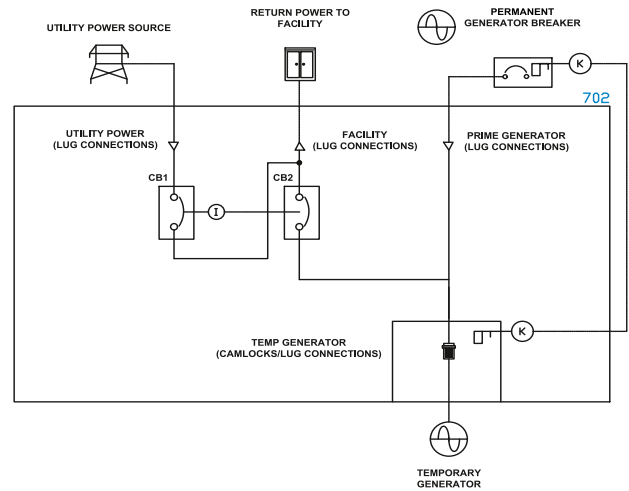

DUAL BREAKER ATS DOCKING STATION - SERVICE ENTRANCE RATED ATS WITH TEMPORARY GENERATOR CONNECTION. TEMPORARY GENERATOR CAMPLATE KIRK KEY INTERLOCKED UPSTREAM CLIENT PERMANENT GENERATOR BREAKER.

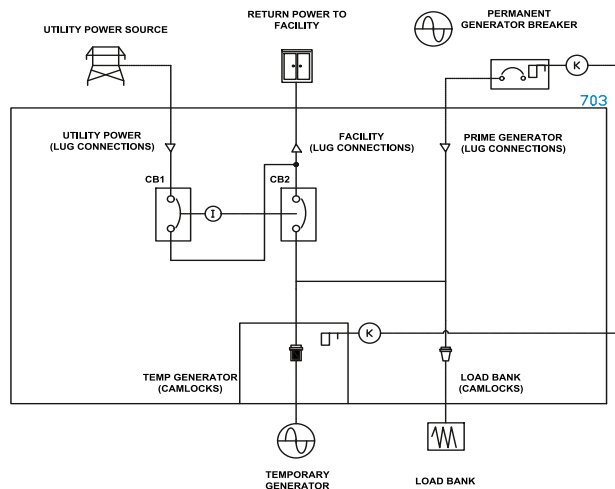

DUAL BREAKER ATS DOCKING STATION - SERVICE ENTRANCE RATED ATS WITH TEMPORARY GENERATOR CONNECTION AND LOAD BANK TESTING. TEMPORARY GENERATOR CAMPLATE KIRK KEY INTERLOCKED UPSTREAM CLIENT PERMANENT GENERATOR BREAKER.

Connection Cabinets

FFCC-ATS Series



Product Selector

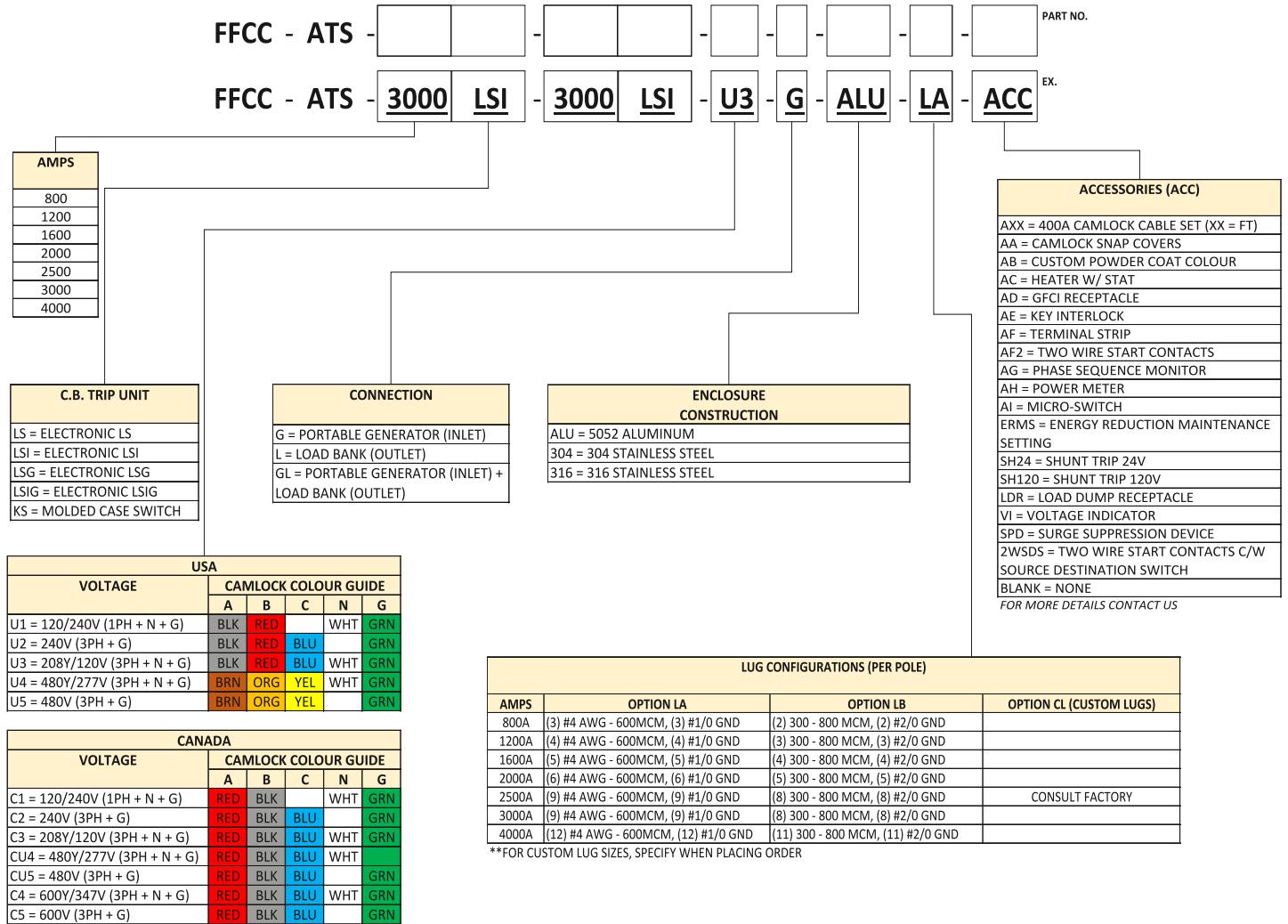

Max Ratings

- 4000A
- 600VAC

Dimensions & Est. Weights

- 90"H x 75"W x 30"D (800A - 2000A) 1610LB
- 90"H x 140"W x 36"D (2500A - 4000A) 4500LB