

Connection Cabinets

FFCS-C3 Series

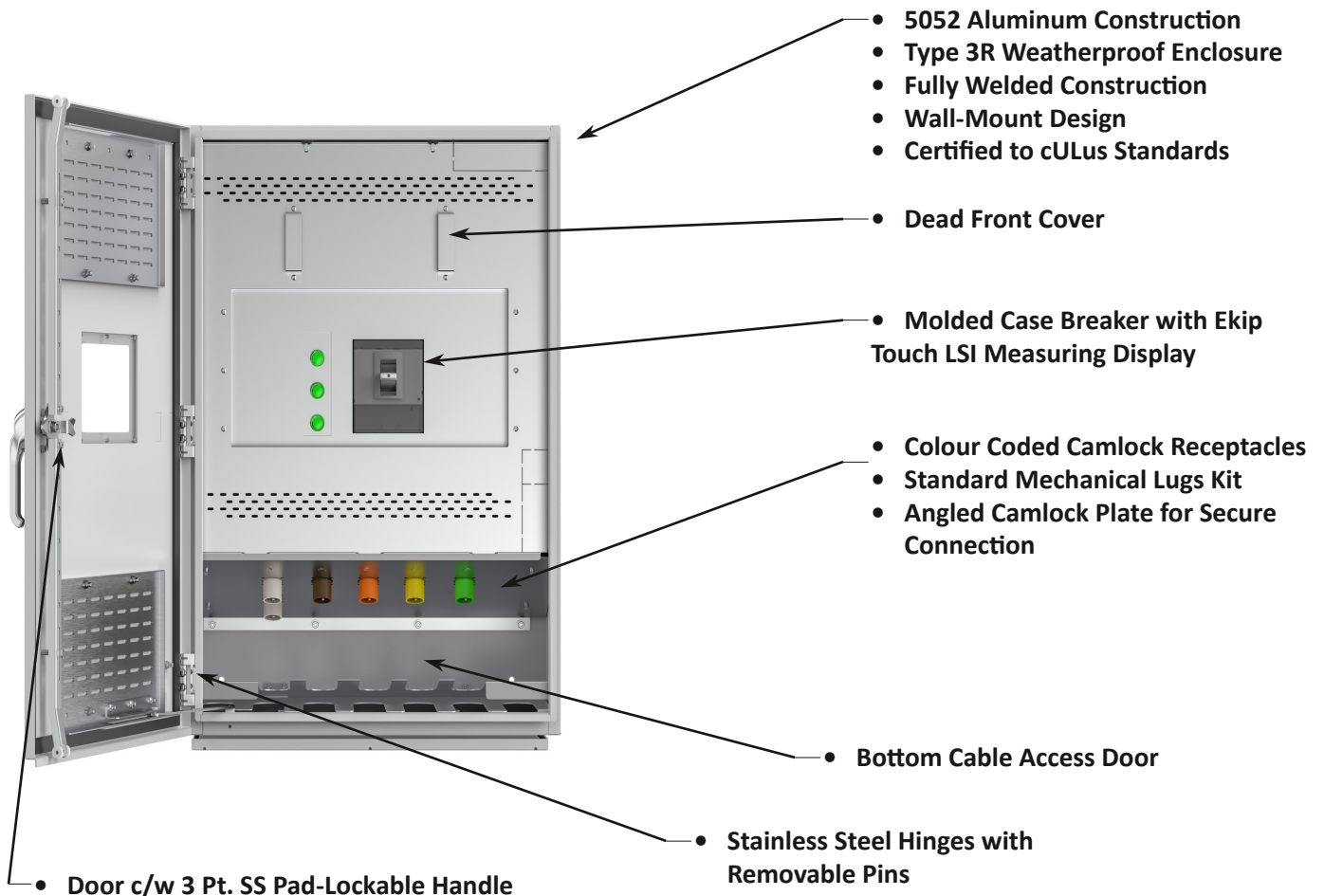

The FFCS-C3 Series Company Switch Connection Cabinets provide a quick and safe power connection point for portable event power, trailers, amusement park setups, food trucks, performance theatre, arena/stadium, and movie set trailers. These units are equipped with a molded case breaker, allowing temporary loads to receive power quickly, safely, and providing overcurrent protection simultaneously. They also come complete with colour-coded camlock receptacles, configurable to suit site requirements allowing for plug-and-play connection, an in-phase measurement display, operation indicator lights, and an operator handle. Dual neutrals are optional for redundancy. Assemblies are available with up to 400A mains and are certified to cULus Standards. Full custom options available, consult factory.



Rev 3.0

Connection Cabinets

FFCS-C3 Series



One-Line Diagram

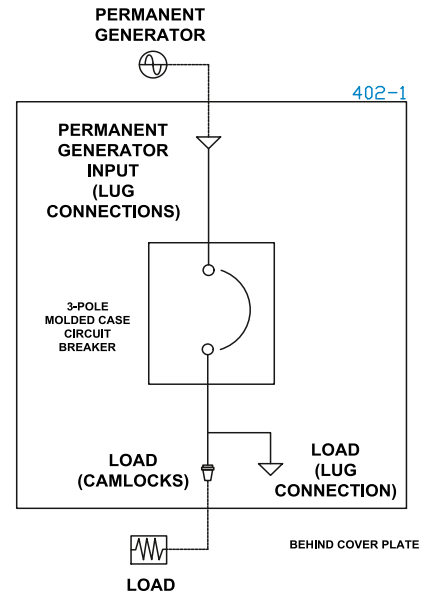
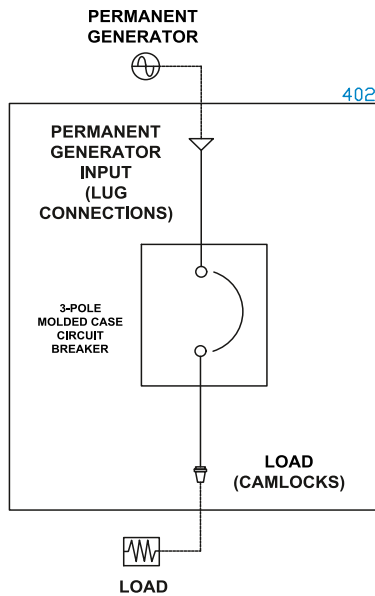

SINGLE BREAKER DOCKING STATION

**SINGLE BREAKER DOCKING STATION
INCLUDES OPTIONAL MECHANICAL LUGS**

Connection Cabinets

FFCS-C3 Series



Product Selector

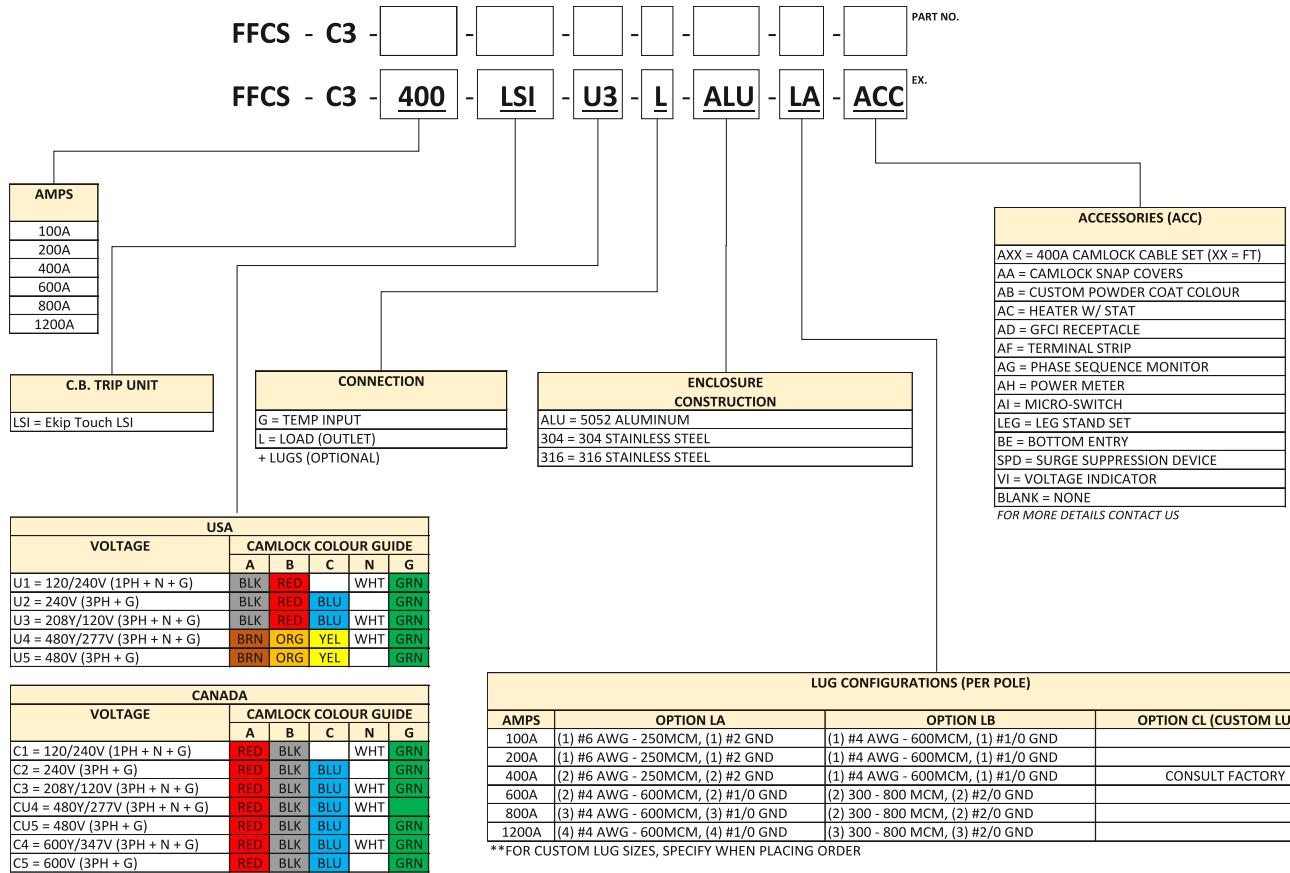

Max Ratings

- 400A
- 600VAC

Dimensions

- 42"H x 30"W x 16"D (100A - 400A) **180LB**
- 60"H x 36"W x 24"D (600A - 1200A) **380LB**