

# CBC 1121 ex CTC 10101 ex E2MS 101 Cargo Piping Diagram

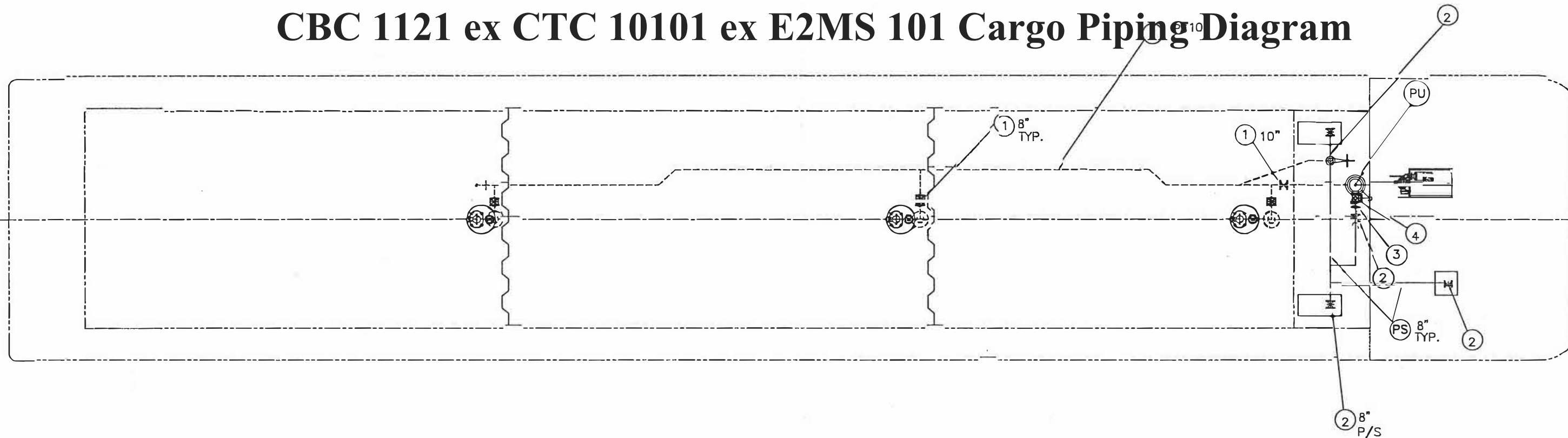

- GENERAL NOTES**
- ALL PIPING TO MEET USCG I REGULATIONS.
  - BACKING RINGS SHALL BE USED AT BUTT WELD JOINTS 2" AND LARGER
  - PIPES PASSING THROUGH WATER/OIL TIGHT BOUNDARIES TO BE WELDED BOTH SIDES.
  - CARGO SYSTEM:  

PRESSURE, WORKING	125 PSI
DESIGN	150 PSI
TEST	225 PSI
RELIEF VALVE	125 PSI
PUMP WELL TEST	15 PSI
  - MATERIAL TO BE AS SPECIFIED OR EQUAL
  - LABELS TO BE INSTALLED ON ALL VALVES WHERE REQUIRED TO IDENTIFY SERVICE.
  - ENGINE SHUT DOWN SHALL BE INSTALLED INCLUDING SIGN (45 CFR 32.50-35)
  - VALVES WHICH ARE LOCATED BELOW DECK WILL BE EQUIPPED WITH SOLID STN STEEL REACH RODS.
  - BARGE IS DESIGNED FOR 6.0f SERVICE.

## CARGO PIPING LIST OF MATERIALS

PC. NO.	PART	DESCRIPTION	MFG	NOMINAL SIZE	MATERIAL	RATING	ASTM NO.	ANSI NO.
PU	CARGO PUMP	11X114GH 3 STAGE PUMP W/RIGHT ANGLE GEAR	BYRON JACKSON					
ENG	ENGINE	MEDO NEF 67 MODEL	LABORDE (OFM)					
1	GATE VALVE	FIG. 15021C, FLG'D NRS	SPACE	ALL	CAST STL./CR13 TRM	150f	A-216 WCB	B16.34
2	GATE VALVE	FIG. 15011C, FLG'D OS&Y	SPACE	ALL	CAST STL./CR13 TRM	150f	A-216 WCB	B16.34
3	RELIEF VALVE	FIG. 260PA10L120, SET @ 125 PSI	TELEDYNE/TARRIS	4XPK6	CAST IRON	150f	A-126 CL. B	B16.34
4	CHECK VALVE	WAFFER STYLE, 150f	DUD CHECK II	8"	CS.	150f	A-216 WCB	B16.34
PS	PIPE	STD. WT., SEAMLESS		2" & ABOVE	STL.		A-53	B36.10
	PIPE FLANGE	WN, SO, BLIND & SW		ALL	STL.	150f	A-105	B16.5
	JOINTS	UNION, COUPLING		2" & BLW	F.S.	3000f	A-105	B16.11
	PIPE FITTINGS	BUTT WELD		ABV 2"	STL.	STD.WT.	A-234	B16.9
	PIPE FITTINGS	SCRD, SW		2" & BLW	F.S.	3000f	A-105	B16.11
	GASKETS	NON-ASBESTOS		ALL	GARLOCK			

*JK*

REV	ITEM	DESCRIPTION	DATE	BY
REVISIONS				

**TRINITY MARINE PRODUCTS, INC.**  
The drawings and the information shown thereon are copyrighted by Trinity Marine Products (2016) and the sole property of Trinity Marine Products. Neither the drawings nor such information is to be used for any purpose other than that for which it was specifically furnished from Trinity Marine Products, LLC, nor in any reproduction without written permission.

**TRINITY MARINE PRODUCTS, INC.**  
 P.O. BOX 700 - Indianola, IA 52647

**E SQUARED MARINE**  
 200'-0" X 35'-0" X 12'-6" DOUBLE SKIN TANK BARGE  
 CARGO PIPING DIAGRAM

SCALE: NTS	DATE: 12/15/16	DWG NO.
DRAWN BY: BP	CK'D BY:	CP-02
YARD:	TAG NO. 96273	SHT 1 OF 1
HULL NO. E2MS 101	SHOP ORDER:	REV. 0

PLOT: 04

# CBC 1121 ex: CTC 10101 ex: E2MS 101 Vapor Piping Diagram

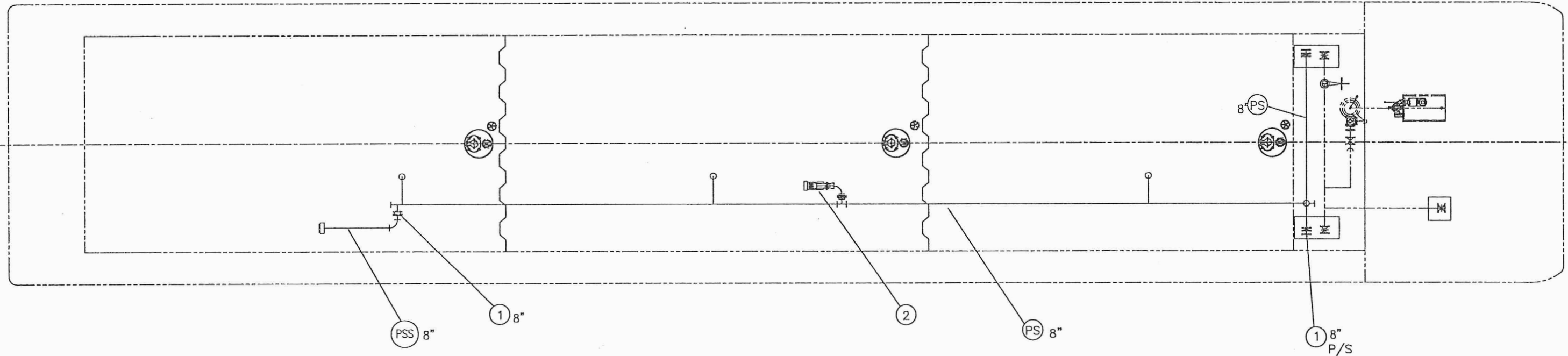

### GENERAL NOTES

1. ALL PIPING TO MEET USCG II REGULATIONS.
2. BACKING RINGS SHALL BE USED AT BUTT WELD JOINTS 2" AND LARGER
3. PIPES PASSING THROUGH WATER/OIL TIGHT BOUNDARIES TO BE WELDED BOTH SIDES.
4. MATERIAL TO BE AS SPECIFIED OR EQUAL.
5. VAPOR HEADER EQUIPPED WITH DRAIN AT LOW POINT.
6. BARGE IS DESIGNED FOR 6.0# SERVICE.

### LIST OF MATERIALS

PC. NO.	PART	DESCRIPTION	MFG	NOMINAL SIZE	MATERIAL	RATING	ASTM NO.	ANSI NO.	COMMENT
1	GATE VALVE	FIG. 15011C, FL'D OS&Y	SPACE	ALL	CAST STL/SS TRM	150#	A-216 WCB	B16.34	
2	PRESSURE-VAC. VALVE	SUPER-AC MODEL II	ERL	6"	STN. STL.				
PS	PIPE	STD. WT., ERW		8"	STEEL		A-53	B36.10	
PSS	PIPE	SCHEDULE 10, SMLS		8"	STAINLESS		A-53	B36.10	
	PIPE FLANGE	W.N., S.O., BLIND		ALL	STEEL	150#	A-181	B16.5	
	PIPE FLANGE	LAP JOINT FLANGE (SWIVEL FLANGE)		8"	STEEL	150#	A-105	B16.5	
	JOINT STUB	LAP JOINT STUB END, SCHEDULE 10, 8" LONG		8"	STAINLESS STEEL	150#	A-304	B36.10	
	JOINT STUB	LAP JOINT STUB END, STD. WT. 4" LONG		8"	STEEL	150#	A-53	B36.10	
	JOINTS	UNION, CPLG, S.W.		ALL	STEEL	3000#	A-105	B16.11	
	PIPE FITTINGS	BUTT WELD,		ALL	STEEL	STD. WT.	A-234	B16.9	
	PIPE FITTINGS	BUTT WELD,		ALL	STAINLESS STEEL	SCH. 10	A-182-F304L	B16.9	
	GASKET	RING TYPE, X 1/8" THICK FOR 150# FLG.	GARLOCK	ALL		150#			
	PRESS GAUGE	4 1/2 DIAL, GLYCERIN FL'D 1/2" NPT LOWER CONN.	ASHCROFT MOD 1279		316 STN. STL.	0-200 PSI			# 45-1279-SSSL 04L-XXX-0/200 PSI

OK

REV	ITEM	DESCRIPTION	DATE	BY
REVISIONS				
<b>TRINITY MARINE PRODUCTS, INC.</b> <small>The drawings and the information shown thereon are copyrighted by Trinity Marine Products (2000) and the sole property of Trinity Marine Products. Neither the drawings nor such information is to be used for any purpose other than that for which it was specifically furnished from Trinity Marine Products, LLC, nor is any reproduction authorized without written permission.</small>				
<b>TRINITY MARINE PRODUCTS, INC.</b> <small>P.O. BOX 700 - Madisonville, LA 70447</small>				
<b>E SQUARED MARINE</b> <b>200'-0" X 35'-0" X 12'-6" DOUBLE SKIN TANK BARGE</b>				
<b>VAPOR PIPING DIAGRAM</b>				
SCALE:	NTS	DATE:	12/15/16	DWG NO.
DRAWN BY:	BP	CK'D BY:		CP-06
YARD:		TAG NO.	96273	SHT 1 OF 1
HULL NO.	5271	SHOP ORDER:		REV. 0