

**REVISIONS**

REV	ZONE	DESCRIPTION	DATE	APPROVED

**VAPOR SYSTEM GENERAL NOTES:**

- VAPOR PIPING IS CLASS II. MAWP IS 125PSI AND TEMP LESS THAN 150°F. CARGO MAWP IS 100 PSI. CARGO PUMP RELIEF VALVE SET AT 125 PSI.
- MAXIMUM DESIGN WORKING PRESSURE OF THE CARGO TANKS IS 3 PSI.
- P/V VALVE IS A 6", ERL "SUPERAC" ALL STAINLESS STEEL. VACUUM RELIEF SET AT 0.5 PSIG VACUUM. PRESSURE SIDED SET AT 1.5 PSIG PRESS. U.S.C.G. APPROVAL NO. 162.017/144/3.
- ALL PIPING TO BE SCH 40 BLK ERW PIPE UNLESS NOTED OTHERWISE. FIT-UP, WELDING & TESTING SHALL BE TO THE SATISFACTION OF THE OCM.
- ALL WELDING TO BE CONTINUOUS OR DOUBLE CONTINUOUS TYPICAL. WELD JOINTS OF PIPING SHALL CONFORM TO 46 CFR 56.30-5 AND 56.30-10 AS APPLICABLE. WELD FITTINGS SHALL BE IAW 46 CFR 56.70 AND PART 57 AS APPLICABLE.

**VAPOR SYSTEM BILL OF MATERIALS**

MK	QTY	SIZE	DESCRIPTION	MATERIAL	ASTM SPEC	ANSI SPEC
P1	AR	8"	PIPE, SCH 40 BLK ERW	STEEL	A53	B36.10
VS	1	8"	PIPE, .1875" WALL VAPOR STACK W/S.S. FLAME SCREEN, RAIN HOOD & SWIVEL FLANGE	304L ST STL	A312	B36.19M-85
PV	1	6"	HIGH VELOCITY PRESS/VAC VALVE, FLGD, TANKTECH MODEL KLPH-6, PRESS SET @ 1.50PSI, VAC SET @ 0.50PSI	304L ST STL	A312	
V1	3	8"	VALVE, GATE, 150# FLGD, OS&Y, R.S., C.S. BODY, CR13 TRIM, SPACE MODEL #15011C	CARBON STL	A216 GR WCB	B16.5
F1	AR	8"	FLANGE, 150# R.F.S.O.	304L ST STL	A312	B16.5
F2	AR	8"	FLANGE, BLIND, 150# R.F.	FORGED STL	A105	B16.5
F3	AR	8"	FLANGE, 150# R.F.S.O.	FORGED STL	A105	B16.5
F4	1	3"	FLANGE, 150# R.F.S.O.	FORGED STL	A105	B16.5
F5	1	3"	FLANGE, BLIND, 150# R.F.	FORGED STL	A105	B16.5

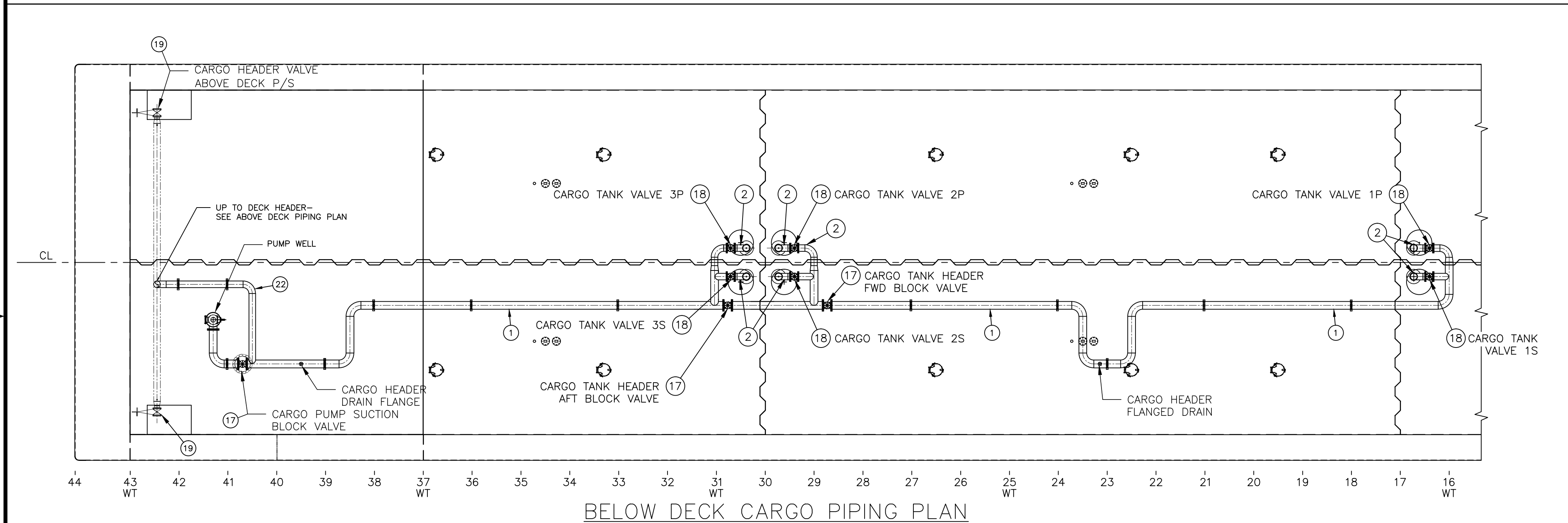

**LEVEL LOADING OF A SINGLE PRODUCT**

DRAFT (FT ABL)	TOTAL P/S CARGO (ST)	TANK		
		3 P or S (ST)	2 P or S (ST)	1 P or S (ST)
2.5	293.94	62.30	42.34	42.34
3.0	529.68	99.07	82.88	82.88
3.5	766.38	135.56	123.82	123.82
4.0	1,003.93	171.63	165.17	165.17
4.5	1,242.31	207.48	206.84	206.84
5.0	1,481.48	242.99	248.87	248.87
5.5	1,721.47	278.20	291.27	291.27
6.0	1,962.26	313.13	334.00	334.00
6.5	2,203.85	347.67	377.13	377.13
7.0	2,446.25	381.97	420.58	420.58
7.5	2,689.45	415.91	464.41	464.41
8.0	2,933.45	449.48	508.62	508.62
8.5	3,178.25	482.84	553.14	553.14
9.0	3,423.85	515.68	598.12	598.12
9.5	3,670.22	548.32	643.40	643.40
10.0	3,917.39	580.74	688.98	688.98
10.5	4,165.34	613.32	734.67	734.67
11.0	4,414.07	646.40	780.32	780.32
11.5	4,663.59	682.86	824.47	824.47

**NOTES:**

- TANK LOAD VALUES FOR LEVEL TRIM.
- FUEL TANK @ 98% FULL, SLOP TANK EMPTY.
- CARGO LIQUID SG = 1.05.
- VESSEL FLOATING IN FRESH WATER.

**CARGO SYSTEM GENERAL NOTES:**

- ALL PIPING SHALL MEET CURRENT USCG REQUIREMENTS FOR CLASS II PIPING SYSTEMS.
- PIPES PASSING THROUGH WATER/OIL TIGHT BOUNDARIES SHALL BE WELDED DOUBLE CONTINUOUS.
- CARGO SYSTEM:
  - PRESSURE: WORKING 100 PSI
  - DESIGN 150 PSI
  - TEST 225 PSI
  - RELIEF VALVE 125 PSI
- ALL HATCHES, MANHOLES, STUFFING GLANDS, ETC. ON THE RAISED TRUNK WITH OPENINGS INTO THE CARGO TANKS SHALL BE FITTED WITH TEFLO GASKETS. ALL HATCHES, MANHOLES, ETC. THAT OPEN INTO VOIDS OUTSIDE OF THE CARGO AREA SHALL BE FITTED WITH NEOPRENE GASKETS.
- CARGO PUMP ENGINE IS A CUMMINS MODEL 6CTAB.3D(M) RATED 270HP @ 1800RPM, IMO, US EPA TIER II COMPLIANT, CLASS I, DIVISION I COMPLIANT.
- CARGO PUMP IS A RUHRPUMPEN MODEL 12LS16GH, 3 STAGE, RATED FOR 4285 BBL/S/HR @ 105 PSI, COMPLETE WITH AN AMARILLO S250 RIGHT ANGLE DRIVE W/1:1 RATIO AND DANA SL1710 x 48" LG. DRIVE SHAFT WITH REMOVABLE GUARD.

**CARGO & STRIPPING SYSTEM BILL OF MATERIALS**

MK	QTY	SIZE	DESCRIPTION	MATERIAL	ASTM SPEC	ANSI SPEC
1	AR	12"	PIPE, SCH 40 BLK ERW	STEEL	A53 GR B	B36.10
2	AR	10"	PIPE, SCH 40 BLK ERW	STEEL	A53 GR B	B36.10
3	AR	6"	PIPE, SCH 40 BLK ERW	STEEL	A53 GR B	B36.10
4	AR	AR	FLANGE, 150# R.F.S.O.	FORGED STEEL	A105	B16.5
5	AR	AR	RING GASKET, 150#, 1/16" THK, NON-ASBESTOS			
6	2	8"	FLANGE, BLIND, 150# R.F.	304 ST STL	A105	B16.5
7	AR	AR	ELBOW, 45° L.R.B.W., SCH 40 BLK	STEEL	A234	B16.9
8	AR	AR	TEE, SCH 40 BLK B.W.	STEEL	A234	B16.9
9	AR	AR	ELBOW, 90° L.R.B.W., SCH 40 BLK	STEEL	A234	B16.9
10	AR	AR	CONCENTRIC REDUCER, SCH 40 BLK B.W.	STEEL	A234	B16.9
11	AR	AR	HALF COUPLING, 3000# THREADED BLK	FORGED STEEL	A105	B16.11
12	1	1 1/4"	SWING CHECK VALVE, 200# SCRD, 316 S.S. TRIM		A351	B16.10
13	1	10"	CHECK VALVE, WAFER TYPE 150# 316 S.S. TRIM	CARBON STEEL	A216	B16.5
14	AR		PRESSURE GAUGE, 4" DIAL, 1/4" MNPT BOTTOM CONN.			
15	1		RELIEF VALVE SET @ 125PSI, TELEDYNE #26PA10L	CARBON STEEL	A216	B16.5
16	1	1 1/4"	GATE VALVE, 200# SCRD, NRS, 316 S.S. TRIM		A351	B16.10
17	3	12"	GATE VALVE, 150# FLGD, NRS, CR13 TRIM	CARBON STEEL	A216 GR WCB	B16.5
18	6	10"	GATE VALVE, 150# FLGD, NRS, CR13 TRIM	CARBON STEEL	A216 GR WCB	B16.5
19	4	8"	GATE VALVE, 150# FLGD, OS&Y, R.S., CR13 TRIM	CARBON STEEL	A216 GR WCB	B16.5
20	AR	2"	PIPE, SCH 40 SEAMLESS	304 ST STL	A320	B36.19
21	AR	2"	FLANGE, 150# R.F.S.O.	304 ST STL	A312	B16.5
22	8	2"	BALL VALVE, FLGD, 800#, FULL PORT, CR13 TRIM	CARBON STEEL	A216 GR WCB	B16.34
23	2	2"	QUICK-CONNECT, MxMNPT W/DUST CAP & LANYARD	BRASS	B62	B1.20.1-B3
24	1	3"	PUMP, AIR DIAPHRAGM, VERSA-MATIC MODEL V3CA3R530	CAST IRON	A126-95	
25	2	2"	GATE VALVE, 150# FLGD, OS&Y, R.S., CR13 TRIM	CARBON STEEL	A216 GR WCB	B16.34
26	1	2"	SWING CHECK VALVE, 150# FLGD, CR13 TRIM	CARBON STEEL	A216 GR WCB	B16.34
27	AR	2"	FLANGE, 150# R.F. BLIND	304 ST STL	A312	B16.5

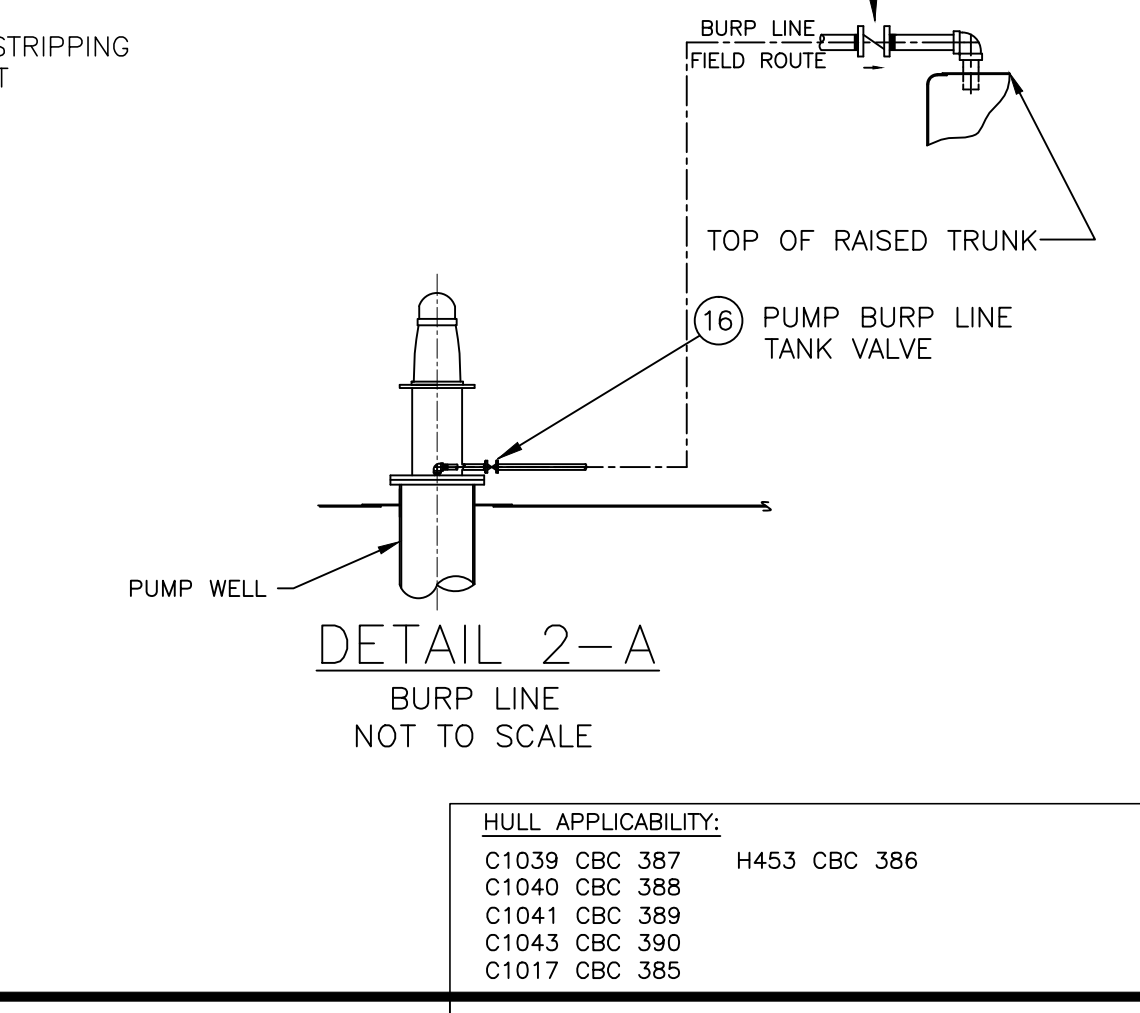
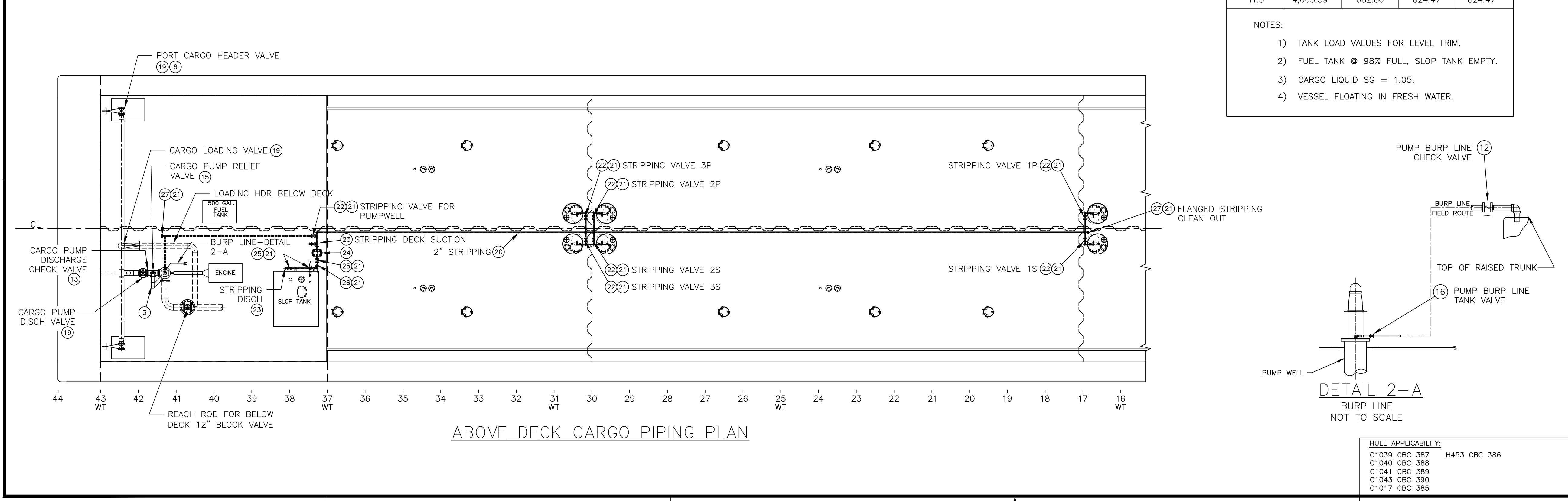

**STRIPPING SYSTEM GENERAL NOTES:**

- STRIPPING PIPING IS CLASS II. MAWP IS 100 PSI AND TEMP LESS THAN 150°F.
- ALL PIPING AND FITTINGS TO BE SCH 40 TYPE 304 STAINLESS STEEL UNLESS NOTED OTHERWISE. PIPING SHALL BE HYDRO-TESTED TO 150 PSI & SHALL BE TO THE SATISFACTION OF THE OCM.
- ALL WELDING TO BE CONTINUOUS OR DOUBLE CONTINUOUS TYPICAL. WELD JOINTS OF PIPING SHALL CONFORM TO 46 CFR 56.30-5 AND 56.30-10 AS APPLICABLE. WELD FITTINGS SHALL BE IAW 46 CFR 56.70 AND PART 57 AS APPLICABLE.

THIS DOCUMENT AND ALL INFORMATION CONTAINED THEREIN ARE THE PROPERTY OF CONRAD SHIPYARD, L.L.C. A CONRAD INDUSTRIES, INC. COMPANY. AND NEITHER RECEIPT NOR POSSESSION THEREOF CONVEYS OR TRANSFERS ANY RIGHTS TO REPRODUCE, DISCLOSE, OR USE IN ANY MANNER THIS DOCUMENT IN WHOLE OR IN PART, OR ANY INFORMATION CONTAINED THEREIN, EXCEPT BY WRITTEN PERMISSION.

**CONRAD Shipyards, L.L.C.**

297'-6" x 54' x 12'-0" DOUBLE SKIN TANK BARGE

**CARGO & VAPOR SYSTEM PIPING DIAGRAM**

DRAWN BY: RLS	SCALE: 3/32"=1'-0"	REVISION: 0	SHEET: 1 OF 1
CHECKED BY: RRN	DATE: 7-15-13	PROJECT: M-100	
ASB APPROVAL: SEE APPLIC			
USCG APPROVAL: SEE APPLIC			

HULL APPLICABILITY:  
C1039 CBC 387 H453 CBC 386  
C1040 CBC 388  
C1041 CBC 389  
C1043 CBC 390  
C1017 CBC 385