



777 Aviation Dr
Camarillo, Ca 93010
USA

March 5th, 2026
Revision C

Maintenance Support Document

ETM1000 - 407- ICA

Instructions for Continued Airworthiness;

Installation of an AKV, Inc Exceedence and Trend
Monitoring System P/N ETM1000 for the Bell 407 limited
to S/N 53000 - 54299

STC Number: SR02413LA

S/N _____





PROPRIETARY. ALL RIGHTS RESERVED. NO PORTION OF THIS DOCUMENT MAY BE REPRODUCED OR TRANSMITTED IN ANY
FORM OR BY ANY MEANS, ELECTRONIC OR MECHANICAL, INCLUDING BY PHOTOCOPYING, RECORDING OR USE OF ANY
INFORMATION STORAGE AND RETRIEVAL SYSTEM WITHOUT EXPRESS WRITTEN PERMISSION OF AKV, Inc.

©2012 AKV, Inc

REVISIONS INTRODUCTION

The latest revision of this document is indicated by the highest revision letter as listed below in the Revision History and List of Effective Pages. Changes to the current revision will be indicated within the document by change bars. (Reference Section 1.) The entire document will be reprinted to reflect the current revision level.

REVISION HISTORY

Instructions for Continued Airworthiness; AKV Inc Exceedence and Trend Monitoring System ETM1000			ETM1000-ICA
Rev.	Date	Revision Description	Approval
NC	December 6 th , 2016	Initial Release	PREPARED J. Gunn
			CHECKED J. Gunn
			APPROVED 
A	September 22 nd , 2018	<ul style="list-style-type: none"> - Updated App. A data. Changed to refer to the User Manual - Adjusted Appendix list due to App. A change - Updated App. D Drawings to include change for remote display and Flightcell DZMx interface - Various changes throughout 	PREPARED J. Gunn
			CHECKED J. Gunn
			APPROVED 
B	November 5 th , 2020	- Added new AA battery holder in place of coin cell and updated Appendix D drawings	PREPARED J. Gunn
			CHECKED J. Gunn
			APPROVED 
C	March 5 th , 2026	- Updated Appendix D drawings to MDL Rev R	PREPARED J. Gunn
			CHECKED J. Gunn
			APPROVED 

LIST OF EFFECTIVE PAGES

All pages are revised when any page is changed so that all pages maintain the same revision level.

PAGE	REVISION	DATE
All	NC	December 6th, 2016
All	A	September 22nd , 2018
All	B	November 5th, 2020
19 - 49	C	March 5th, 2026

TABLE OF CONTENTS

1. INTRODUCTION	1
1.1 Service Difficulties.....	1
1.2 Warnings, Cautions, and Notes.....	1
1.3 Language	1
1.4 References.....	1
1.5 Revision to ICA	1
1.6 Abbreviations and Definitions	2
2. AIRWORTHINESS LIMITATIONS.....	2
3. DESCRIPTION	2
3.1 ETM1000 Configurations	2
3.2 ETM1000 Basic Operation.....	4
4. MAINTENANCE INSTRUCTIONS.....	5
4.1 Routine Cleaning & Maintenance	5
4.2 Tools	5
4.3 Overhaul.....	5
4.4 Component Retirement/Retirement Life	5
5. REQUIRED INSPECTIONS	8
5.1 Scheduled Inspection Program.....	8
5.2 Special Inspection.....	8
6. REMOVING AND REPLACING PARTS	12
6.1 To Remove the ETM1000.....	12
6.2 To Replace the Airspeed Switch.....	12
6.3 To Replace the Pushbutton Switches.....	12
7. TROUBLESHOOTING	13
8. WEIGHT AND BALANCE CHANGES	13

APPENDIX A (Configuring the ETM1000)	14
APPENDIX B (Airspeed Switch Installation Instructions)	14
APPENDIX C (Pushbutton Indicator Removal/Installation Instructions)	16
APPENDIX D (Wiring Diagram)	19

1. INTRODUCTION

This AKV, Inc maintenance support document provides instructions for the continued airworthiness of the AKV Exceedence and Trend Monitoring System ETM1000. The basis for this document is 14 CFR 27.1529 and Appendix A to Part 27.

1.1 Service Difficulties

Technical Assistance can be provided by:

AKV, Inc.
777 Aviation Dr.
Camarillo, CA 93010
Tel 805-437-1739
Fax 805 437-1783
Email: sales@akvinc.com
Web: www.akvinc.com

1.2 Warnings, Cautions, and Notes

WARNING

**FAILURE TO FOLLOW INSTRUCTIONS GIVEN IN A WARNING MAY
RESULT IN PERSONAL INJURY OR DEATH.**

CAUTION

*FAILURE TO FOLLOW INSTRUCTIONS GIVEN IN A CAUTION MAY
RESULT IN DAMAGE TO THE HELICOPTER*

Note

A note includes supplemental data about the procedure, practice, condition, etc., for the maintenance task you are about to perform.

1.3 Language

This manual is written to the Simplified English (SE) specification. This International Aerospace Maintenance Language Specification is important to maintenance personnel whose first language is not English.

1.4 References

The use of parentheses throughout this document is for denoting or depicting a reference to other sections, items, details, etc., the intent of which is to further identify or clarify existing information.

1.5 Revision to ICA

Revisions to this document and the documents listed within it are distributed to the operators who have this modification installed on the subject aircraft, either in electronic or paper format. **Contact AKV for available revision changes.**

1.6 Abbreviations and Definitions

A&P	Airframe & Powerplant Mechanic
CFR	Code of Federal Regulations
RFM	Rotorcraft Flight Manual
RFMS	Rotorcraft Flight Manual Supplement
FAR	Federal Aviation Regulations

2. AIRWORTHINESS LIMITATIONS

This section is FAA approved and specifies the inspections, and other maintenance, which are required under 14 CFR 43.16 and 91.403, unless an alternative program has been FAA approved. There are “No airworthiness limitations associated with this type design change”.

3. DESCRIPTION

3.1 ETM1000 Configuration

The ETM1000 is available in two configurations. One is with the pushbutton / indicators (annunciators) on the instrument panel and audio side-tone as a -1 wire harness configuration, or one without as a -2 wire harness configuration. The ETM1000 enclosure is mounted on the pilot side below the instrument panel. It is electrically connected to the existing signal generators for Tq, MGT, N1, N2 and Nr behind the instrument panel and at the rear of each indicator. The system also receives airspeed indication in the form of a calibrated 40kt airspeed switch connected via a “tee” fitting in the pitot line and mounted in the forward section of the instrument panel area. It provides a signal to the ETM1000 that the A/C is operating 100Kt or greater and is utilized for Tq exceedence criteria. An OAT probe is mounted on the belly and the ETM1000 LRU has a pressure altitude (PA) sensor built-in. The OAT and PA sensor are used for the Delta Ng and power check recording.

As a -1 configuration, two (2) instrument panel mounted pushbutton / indicators (annunciators) and audio side-tone are provided for overall status indication pilot interface. A flip guard is installed on the P-PWR/CHK (left side switch) to prevent inadvertent operation. The “P” in the P-PWR/CHK and P-MUTE white nomenclature indicates the pushbutton feature.

As a -2 configuration, there are no pushbutton / indicators or audio side-tone supplied for pilot interaction.

The system date and time is backed up with an externally mounted battery for easy access which is **replaced annually**. A Single power source via a 2 amp circuit breaker supplies power to the ETM1000.

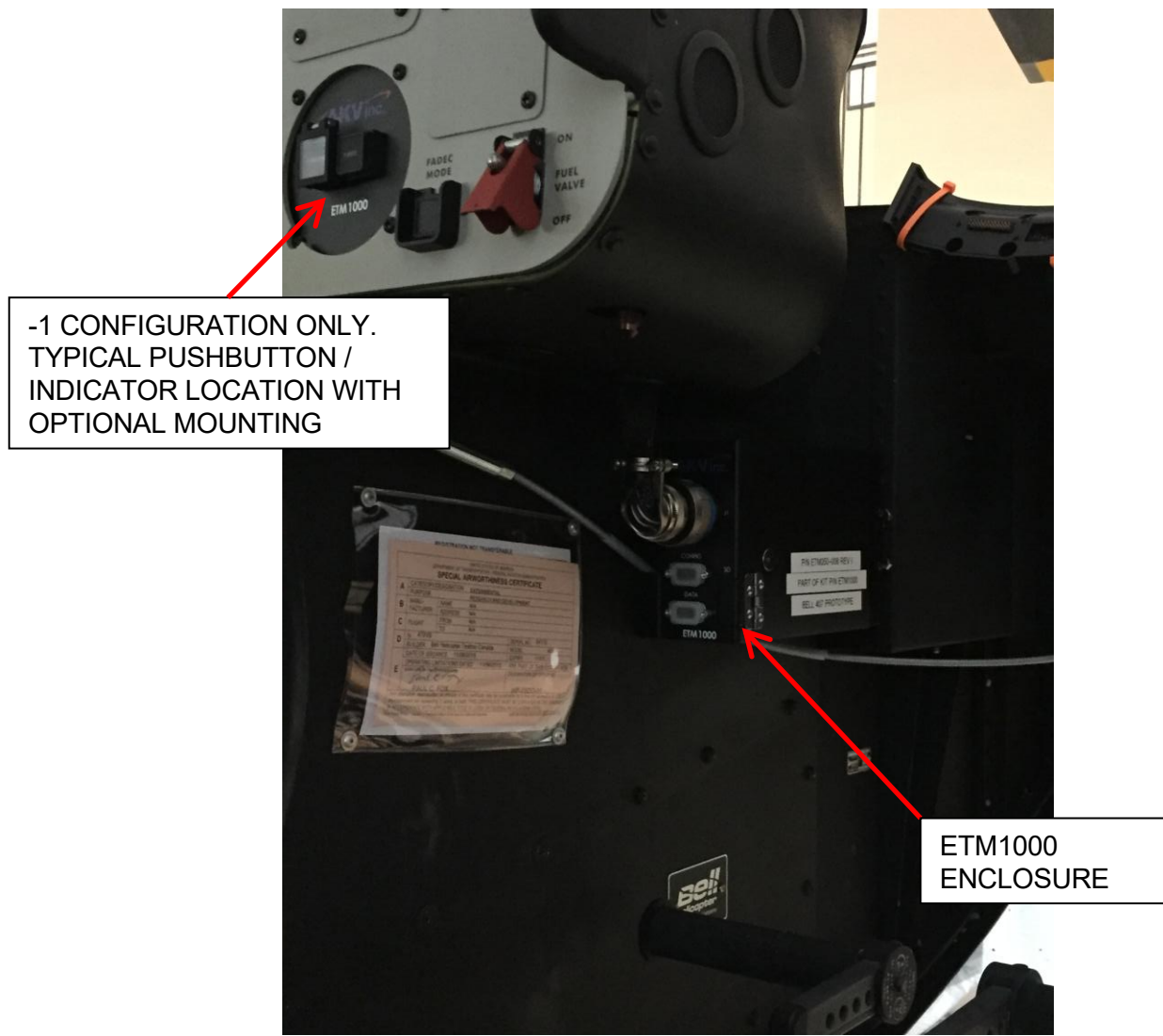

-1 CONFIGURATION ONLY.
TYPICAL PUSHBUTTON /
INDICATOR LOCATION WITH
OPTIONAL MOUNTING

ETM1000
ENCLOSURE

Figure 1 - Installed Views of the ETM1000

3.2 ETM1000 Basic Operation

The ETM1000 is designed to continuously monitor and record all engine and drive train parameters at 1Hz (1/sec). For values in excess of the airframe and engine operating limitations during an exceedance, it is recorded at 5hz (5/sec). The 1Hz data referred to as a Run Log (RL) is used during post flight for graphing normal flight operations. Exceedence data is also graphed.

As a -1 configuration system health and exceedence status indication via white caution and blue warning indicators is provided to the pilot via two (2) pushbutton / annunciators mounted on the instrument panel. An audible side tone for the pilot's headset is also provided for caution and warning indication. Audible muting and a power check recording feature is provided as part of the pushbuttons.

As a -2 configuration there is no pilot interface and the ETM1000 system is essentially a black box recorder.

All data is written to a removable 2GB SD Card. Exceedances are backed up in the ETM1000 flash memory in case the SD card is missing.

NOTE: For additional information, refer to the **ETM1000 User Manual**.

4. MAINTENANCE INSTRUCTIONS

4.1 Routine Cleaning & Maintenance

Routine Cleaning & Maintenance of the ETM1000 Routine maintenance may be required as the result of an inspection. Re-tighten loose fasteners to the standard torque values shown in Table 1 and Table 2. Perform routine cleaning to remove contaminants from the ETM1000. Remove grease, fungus, and ground-in dirt from equipment and mounting brackets using a clean, soft cloth dampened with mild soap and warm water; avoid damaging the coating.

4.2 Tools

The following tools will be necessary to maintain the AKV ETM1000 Installation:

- A Laptop PC utilizing Windows XP or later operating system
- RS-232 cable as supplied with the ETM1000 kit
- USB adaptor as supplied with the ETM1000 kit
- Pitot test set (user supplied)

4.3 Overhaul

There are no component overhaul requirements for this type design change. Under normal operating conditions, the ETM1000 will not require component overhaul. All parts and assemblies are designed to be replaced "On Condition". Any maintenance needed to the ETM1000 or its installation beyond that described in this document requires that the components be removed and returned to AKV, Inc. The decision to return damaged components may be a subjective one and should be made by a qualified A & P Mechanic.

4.4 Component Retirement/Retirement Life

The ETM1000 has been designed with components that have a virtually unlimited life span. However, it is anticipated that some components may require replacement at some time during the service life of the helicopter. The decision to replace these parts is a subjective one and should be made by the operator or an A & P Mechanic.

Bolts -- Steel Tension		Bolts -- Steel Tension		Bolts -- Aluminum								
AN 3 – AN 20		MS 20004 – MS 20024		AN 3DD – AN 20DD								
AN 42 – AN 49		NAS 144 – NAS 158		AN 173DD – AN 186DD								
AN 73 – AN 81		NAS 583 – NAS 590		AN 509DD								
AN 173 – AN 186		NAS 144 – NAS 158		AN 525D								
MS 20033 – MS 20046		NAS 144624 – NAS 644		MS 27039D								
MS 20073		NAS 1303 – NAS 1320		MS 24694DD								
MS 20074		NAS 172		-----								
AN 509 NK9		NAS 174		-----								
MS 24694		NAS 517		-----								
AN 525 NK525		-----		-----								
MS 27030		-----		-----								
		Steel Shear Bolt										
		NAS 464										
Nuts		Nuts		Nuts								
Steel Tension	Steel Shear	Steel Tension	Steel Shear	Aluminum Tension	Aluminum Shear							
AN 310	AN 320	AN 310	AN 320	AN 365D	AN320D							
AN 315	AN 364	AN 315	AN 364	AN 310D	AN 364D							
AN 363	NAS 1022	AN 363	NAS 1022	NAS 1021D	NAS 1022D							
AN 365	MS 17826	AN 365	MS 17826	-----	-----							
NAS 1021	MA 20364	MS 17825	MS 20364	-----	-----							
MS 17825	-----	MS 20365	-----	-----	-----							
MS 21045	-----	MS 21045	-----	-----	-----							
MS 20365	-----	NAS 1021	-----	-----	-----							
MS 20500	-----	NAS 679	-----	-----	-----							
NAS 679	-----	NAS 1291	-----	-----	-----							
FINE THREAD SERIES ¹												
Nut-Bolt Size	Torque Limits In-lbs.		Torque Limits In-lbs.		Torque Limits In-lbs.		Torque Limits In-lbs.		Torque Limits In-lbs.		Torque Limits In-lbs.	
	Min.	Max	Min.	Max	Min.	Max	Min.	Max	Min.	Max	Min.	Max
8 - 36	12	15	7	9	-----	-----	-----	-----	5	10	3	6
10 - 32	20	25	12	15	25	30	15	20	10	15	5	10
1/4 - 28	50	70	30	40	80	100	50	60	30	45	15	30
5/16 - 24	100	140	60	85	120	145	70	90	40	65	25	40
3/8 - 24	160	190	95	110	200	250	120	150	75	110	45	70
7/16 - 20	450	550	270	300	520	630	300	400	180	280	110	170
1/2 - 20	480	690	290	410	770	950	450	550	280	410	160	260
9/16 - 18	800	1000	480	600	1100	1300	650	800	380	580	230	360
5/8 - 18	1100	1300	660	780	1250	1550	750	950	550	670	270	420
3/4 - 16	2300	2500	1300	1500	2650	3200	1600	1900	950	1250	5560	880
7/8 - 14	2500	3000	1500	1800	3550	4350	2100	2600	1250	1900	750	1200
1 - 14	3700	4500	2200	3300	4500	5500	2700	3300	1600	2400	950	1500
1 1/8 - 12	5000	7000	3000	4200	6000	7300	3600	4400	2100	3200	1250	2000
1 1/4 - 12	9000	11000	5400	6600	11000	13400	6600	8000	3900	5600	2300	3650

Table 1: Recommended torque values for nut-bolt combinations: Fine Thread Series

¹ Torque values without lubrication

Bolts -- Steel Tension		Bolts -- Steel Tension		Bolts -- Aluminum								
AN 3 – AN 20		MS 20004 – MS 20024		AN 3DD – AN 20DD								
AN 42 – AN 49		NAS 144 – NAS 158		AN 173DD – AN 186DD								
AN 73 – AN 81		NAS 583 – NAS 590		AN 509DD								
AN 173 – AN 186		NAS 144 – NAS 158		AN 525D								
MS 20033 – MS 20046		NAS 144624 – NAS 644		MS 27039D								
MS 20073		NAS 1303 – NAS 1320		MS 24694DD								
MS 20074		NAS 172		-----								
AN 509 NK9		NAS 174		-----								
MS 24694		NAS 517		-----								
AN 525 NK525		-----		-----								
MS 27030		-----		-----								
		Steel Shear Bolt										
		NAS 464										
Nuts		Nuts		Nuts								
Steel Tension	Steel Shear	Steel Tension	Steel Shear	Aluminum Tension	Aluminum Shear							
AN 310	AN 320	AN 310	AN 320	AN 365D	AN320D							
AN 315	AN 364	AN 315	AN 364	AN 310D	AN 364D							
AN 363	NAS 1022	AN 363	NAS 1022	NAS 1021D	NAS 1022D							
AN 365	MS 17826	AN 365	MS 17826	-----	-----							
NAS 1021	MA 20364	MS 17825	MS 20364	-----	-----							
MS 17825	-----	MS 20365	-----	-----	-----							
MS 21045	-----	MS 21045	-----	-----	-----							
MS 20365	-----	NAS 1021	-----	-----	-----							
MS 20500	-----	NAS 679	-----	-----	-----							
NAS 679	-----	NAS 1291	-----	-----	-----							
COARSE THREAD SERIES ²												
Nut-Bolt Size	Torque Limits In-lbs.		Torque Limits In-lbs.		Torque Limits In-lbs.		Torque Limits In-lbs.		Torque Limits In-lbs.		Torque Limits In-lbs.	
	Min.	Max	Min.	Max	Min.	Max	Min.	Max	Min.	Max	Min.	Max
8 - 32	12	15	7	9	-----	-----	-----	-----	-----	-----	-----	-----
10 - 24	20	25	12	15	-----	-----	-----	-----	-----	-----	-----	-----
1/4 - 20	40	50	25	30	-----	-----	-----	-----	-----	-----	-----	-----
5/16 - 18	80	90	48	55	-----	-----	-----	-----	-----	-----	-----	-----
3/8 - 16	160	185	95	110	-----	-----	-----	-----	-----	-----	-----	-----
7/16 - 14	235	255	140	155	-----	-----	-----	-----	-----	-----	-----	-----
1/2 - 13	400	480	240	290	-----	-----	-----	-----	-----	-----	-----	-----
9/16 - 12	500	700	300	420	-----	-----	-----	-----	-----	-----	-----	-----
5/8 - 11	700	900	420	540	-----	-----	-----	-----	-----	-----	-----	-----
3/4 - 10	1150	1600	700	950	-----	-----	-----	-----	-----	-----	-----	-----
7/8 - 9	2200	3000	1300	1800	-----	-----	-----	-----	-----	-----	-----	-----
1 - 8	3700	5000	2200	3000	-----	-----	-----	-----	-----	-----	-----	-----
1 1/8 - 8	5500	6500	3300	4000	-----	-----	-----	-----	-----	-----	-----	-----
1 1/4 - 8	6500	8000	4000	5000	-----	-----	-----	-----	-----	-----	-----	-----

Table 2: Recommended torque values for nut-bolt combinations: Coarse Thread Series

² Torque values without lubrication

5. REQUIRED INSPECTIONS

5.1 Scheduled Inspection Program

This section contains the time limit intervals and requirements for the scheduled and conditional inspections for the ETM1000 Installation. The inspection items are determined through experience, tests, and the judgment of mechanics and engineers. Every calendar and hourly inspection is a visual and thorough inspection to determine the airworthiness of the ETM1000. Qualified persons must perform the inspections in accordance with standard aircraft practices and the applicable maintenance manuals.

An Annual inspection using this **ETM1000-ICA** document (Instructions for Continued Airworthiness), is required unless another inspection has been approved by the Federal Aviation Administration. When using **ETM1000-ICA** to perform the required inspections, use the "Inspection Task Description" forms below to record the appropriate data.

Any reference data needed to perform this inspection, other than this document, will be listed in the "Data Reference" column of the inspection forms.

The inspection task to be completed is described in the "Inspection Task Description" column of the inspection form.

When each task is satisfactorily completed, the mechanic performing the inspection task signs the "Mechanic" column for that task.

If the inspection task fails the inspection, the reason for the failure must be determined and remedial action taken before the "Mechanic" block can be signed off. Remedial action may involve cleaning, adjusting the tightness of fasteners and hardware, sending the assembly to the manufacturer for overhaul or replacement, etc. Once the appropriate remedial action has been taken and the inspection task has been satisfactorily performed, the mechanic may sign off the "Mechanic" block.

Once all tasks are signed off in the "Mechanic" Column, the inspection form may be signed off at the top of the form and the inspection has then been completed.

5.2 Special Inspection

In the event of a hard landing, perform the "Annual Inspection" tasks prior to returning the aircraft to service.

Helicopter S/N: _____ Registration: _____
 Facility: _____ W.O.: _____
 A/F Total time: _____ Rin: _____
 Engine Total time: _____ Cycle: _____
 Date started: _____ Date completed: _____
 Signature: _____ License number: _____

Annual Inspection

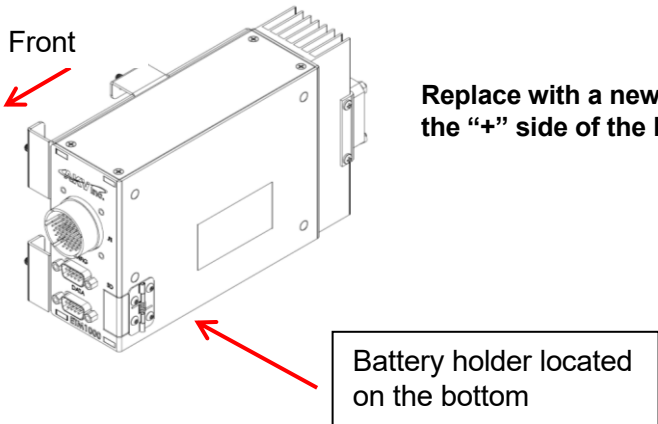
Data Reference	Inspection Task Description	Mechanic
ETM1000 User Manual v7.0 or later	<p>Replacement of the Lithium Backup AA battery for Rev Q and later LRU's</p> <p>The new 3.6V AA Lithium “button top” style battery should be replaced bi-annually in order to provide continued retention of the date / time clock. The 3.6V AA Lithium battery is a standard industry lithium battery that can be purchased from AKV, Inc.</p> <p>Caution: Do not use a standard AA battery which has insufficient voltage of 1.5V</p> <p>With the A/C battery switch “OFF”, remove the battery holder cap by twisting counter clockwise. After the new battery has been installed, make sure the cap is installed and is fully tightened.</p> <p>You will now need to reset the date and time. Locate and connect the supplied RS232 cable to the “config” port just below the J1 connector. Connect the cable to a PC running Microsoft XP, 2000, Vista or Windows 7 or 10 using the 9 pin serial port. If a 9 pin serial port is not available then use the supplied USB / Serial adapter.</p>  <p>Replace with a new battery making sure the “+” side of the battery is down.</p>	

Data Reference	Inspection Task Description	Mechanic
ETM1000 User Manual v7.0 or later	<p>Operational Check</p> <p>The PC you will use must have been set up for communication via “HyperTerminal” prior to using the following procedure.</p> <p>Perform the following steps to verify proper operation of the ETM1000.</p> <ol style="list-style-type: none"> Use a PC running Windows XP or greater O/S and connect to the “Config” port using the AKV supplied RS232 9-pin serial cable. Use the AKV supplied USB/Serial adaptor if your PC does not have a 9 pin serial port available. <p><u>If you have a -2 configuration without the pushbutton / indicators and audio side-tone, goto step 7</u></p> <ol style="list-style-type: none"> If the indicators are known to be activated from within the configuration settings of Hyperterminal, turn the A/C battery switch “ON” and observe that the annunciator lights are illuminated as follows during system BIT self-check: <div style="text-align: center; margin: 10px 0;">  </div> NOTE: If the WARNING light stays illuminated then there has been a prior exceedence that has not been acknowledge and cleared by maintenance. Remove the SD card to confirm what has been exceeded, verify corrective action then reset the light. If the SD light stays illuminated then check the SD card is inserte d. If it is flashing then the SD card nearly full and data must be removed. If the SD card is bad then replace it. If the ERR light stays illuminated then there is a faulty connection with one of the signals to the ETM1000. Use HyperTerminal to determine which signal is faulty. * Ref. Appendix D for the Wiring Diagrams. If the audio is known to be activated from within the configuration settings of Hyperterminal and with the headset on your head, check that the audio side tone is heard by cycling the ETM circuit breaker. If it is weak or load, adjust the audio control head unit for a comforatbel level. It is not adjustable within the ETM1000. Check the cooling fan on the rear of the ETM1000 enclosure below the instrument panel for positive airflow by placing your hand next to the fan. Check the fan bearings are not noisy and the fan is clean and provides airflow by placing your hand over the rear of the ETM1000 enclosure. On your PC, locate and run the Windows native program called “HyperTerminal” 	

Data Reference	Inspection Task Description	Mechanic
ETM1000 User Manual v7.0 or later	<ol style="list-style-type: none"> 11. Check that the Collective Time, Engine Run Time and Engine Starts are correct, If not then enter "S" for settings, enter the password and change the appropriate field as required. See Appendix D for instructions on how to change the Engine Run Times. 12. Start the A/C and run at ground idle. 13. Check that the engine parameters for Tq, MGT, N1, N2 and Nr values in "HyperTerminal" correspond with the indicators on the instrument panel +/- 1% NOTE: During startup it is normal to sometimes see the ERR light flash on for 1-2 secs. This can vary between different A/C. 14. Run the A/C at flight speed and again, check the engine parameters for accuracy. +/- 1% 15. Return to ground idle and shutdown the engine. 16. Set the altimeter to 29.92 and verify the Pressure Altitude in "HyperTerminal" is within approximately 300ft. 17. Check that the OAT value in "HyperTerminal" is with 5 deg C of the A/C OAT probe. Keep in mind that the ETM1000 OAT probe is mounted on the belly of the A/C and could be receiving additional heat form the ground when compared to the A/C OAT probe mounted above the canopy. 18. Connect a pitot test set to the A/C pitot tube and while monitoring "HyperTerminal" check that the "Air speed Switch" goes from "0" (OFF) to a "1" (ON) when the test set is adjusted to 100Kt or greater. Tolerances is Activation +0 / -5 MPH and Deactivation -2 / -6 MPH * Ref. Appendix D for the Wiring Diagrams. <p>END OF PROCEDURE</p>	

6. REMOVING AND REPLACING PARTS

Remove instructions for the AKV ETM1000 are listed below.

6.1 To Remove the ETM1000 LRU

Note: The ETM1000 Enclosure is secured to the mounting plate with four (4) ball studs that allow for a quick-release.

- a) Disconnect the airframe P1 electrical connector from the J1 ETM1000 enclosure electrical connector
- b) Place your hands on the front and rear of the enclosure
- c) Pull the enclosure directly towards you and away from the mounting bracket

6.2 To Remove the Airspeed Switch

See Appendix B for the Airspeed Switch Installation Instructions.

6.3 To Remove the Pushbutton Switches

See Appendix C for the Pushbutton Indicator Removal / Installation Instructions.

7. TROUBLESHOOTING

The troubleshooting table provides the mechanic with guidance for diagnosing malfunctions and the recommended course of action to remedy the fault. Additional help can be found in the Inspection Task (operational task) on Pg 9 or by contacting AKV. See Page 1 for support contact information.

Fault	Probable Cause	Action
No power to unit when aircraft battery power applied	1. Check Circuit breaker 2. Check J1 Connector	1. Reset the Circuit breaker 2. Turn off aircraft battery power and check connector with reference to Appendix G Drawings
Minimal or no airflow from cooling fan.	Cooling fan inoperative.	Check for obstruction and with the power off, check that the fan moves freely and is clean of dust.
Loss of date and time clock indicated by flashing ERR	1. Battery hold tab loose 2. Battery is weak. Min2.9V	1. return LRU to AKV 2. Replace battery with a new one

8. WEIGHT AND BALANCE CHANGES

In the event the ETM1000 has to be removed for maintenance, use the following table to adjust the aircraft weight and balance data.

Component	Weight
ETM1000 Enclosure P/N ETM350-006	1.5 lbs 0.68 kg
Mounting Bracket P/N ETM350-007	0.25 lbs 0.12 kg

Appendix A

A. CONFIGURING HYPERTERMINAL

For Instructions on configuring the ETM1000 refer to the ETM1000 User Manual v7.0 or later

Appendix B

B. AIRSPPEED SWITCH INSTALLATION INSTRUCTIONS

Intended Use:

The intended use of the airspeed switch is to provide an airspeed signal at = > 80 Knots for torque exceedence criteria.

System Description:

This airspeed switch utilizes the existing Pitot system to provide the needed pressures for switch actuation. A ground leg is connected through the airspeed switch and will supply a ground connection for the ETM when the airspeed is = > 100 Kt.

Note: This installation will have negligible effect on aircraft weight and balance

WARNING: When performing pitot/static systems certification you must connect the vent nipple on the AS9300-603-A switch to the static source on the test box to prevent damage to the switch diaphragm. The vent nipple bleed hole must be sealed to prevent leakage during testing. Do not connect vent nipple to the ships static system except during testing. Do not remove sealant compound from around switch terminals or pressure nipple bleed hole. Removal will cause leakage when performing a pitot system check.

CHECKOUT PROCEDURES:

Required Equipment:

- Pitot test set.

Test:

- 1) Test the Pitot system in accordance with the aircraft manufacturer's instructions. If the manufacturer has not issued instructions for testing Pitot systems, utilize the procedures contained in AC 43.13-1A or later approved revision.
- 2) Apply power to the aircraft and observe that the circuit protective device (circuit breaker or fuse) does not "trip" or "blow". Repair wiring if necessary for proper circuit protective device operation.
- 3) After the Pitot system has been successfully leak tested, adjust Pitot test set to indicate zero knots.
- 4) Observe that the Airspeed is "OFF (0)" via the laptop PC running "HyperTerminal". If the Airspeed is "ON (1)," check for the proper airspeed switch electrical connections. Incorrect switch connections will cause the ETM to not function correctly when determining a torque exceedence in flight.
- 5) Adjust the airspeed to equal 100 Knots or greater and observe that the Airspeed is "ON (1)". If the Airspeed does not turn "ON", check connections on airspeed switch or repair wiring as necessary.

NOTE: Tolerances are Activation +0 / -5 MPH and Deactivation -2 / -6 MPH

- 6) Disconnect the Pitot test equipment from the aircraft.
- 7) Make the appropriate entries in the aircraft log book indicating a Pitot system test, and the airspeed switch installation have been completed.

BLANK

Appendix C

C. Pushbutton Indicator Removal/Installation Instructions

- 1) Examine the two sides of the switch cap to ensure the extraction slots are completely visible.

Note: To release the switch cap from the actuated position, simply push in the switch cap and allow the cap to return to the released position.

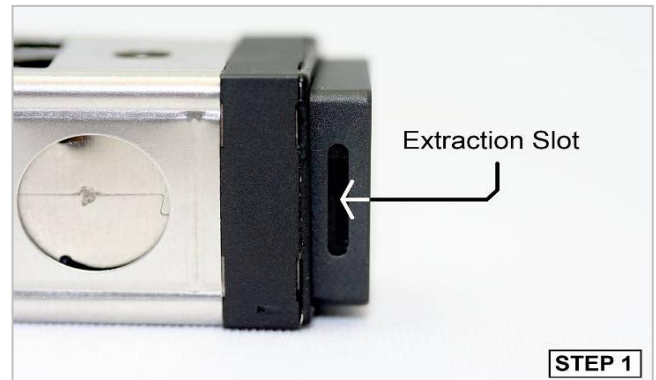

- 2) Extract the switch cap by using the Cap Extractor Tool (Part Number: 17-150) or by applying finger pressure on two sides of the switch cap then pull the switch cap from the switch body.

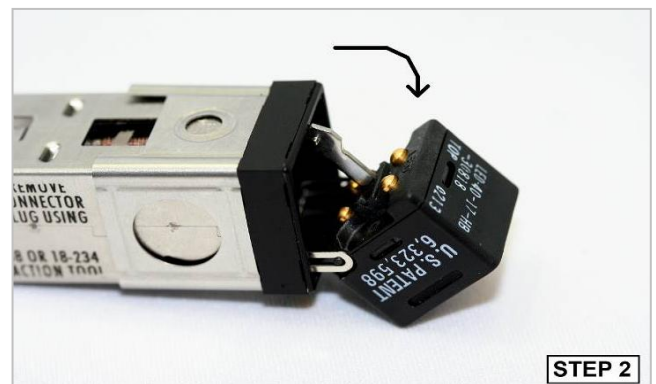

- 3) Remove switch cap from the switch body by gently removing the cap pins from the metallic retainer.

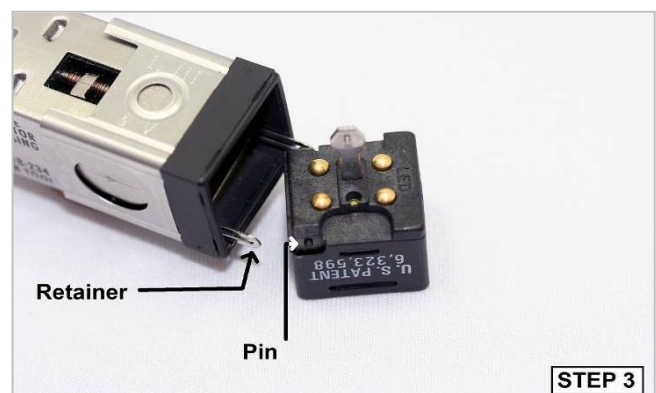

- 4) Remove the mounting sleeve by sliding the sleeve over the switch body from the back.

Note: The optional spacer can also be removed by sliding it from the back of the switch body.



- 5) Insert the back of the switch body into the panel cutout and slide it through the panel from the front. Ensure the switch body label "TOP" is up.



- 6) From behind the mounting panel, replace the mounting sleeve onto the switch body and slide it up to the back of the mounting panel.



- 7) From the front and inside of the switch body, tighten the two screws until the Integral Mounting Hardware pulls the mounting sleeve tight up against the mounting panel. Typical torque is 18 inch ounces.

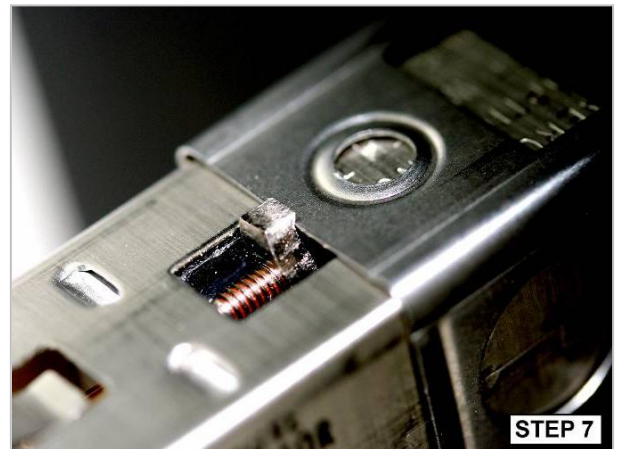
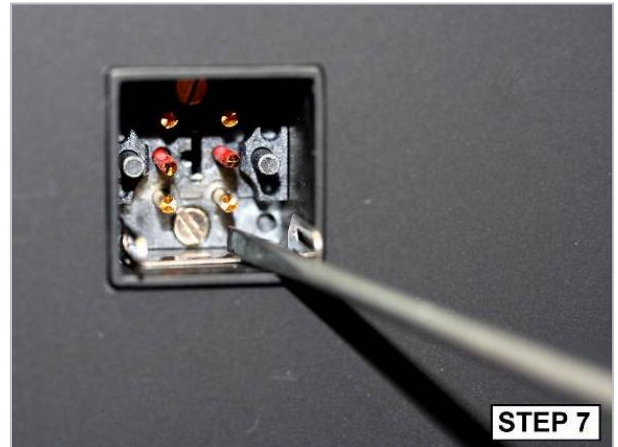

- 8) Replace the switch cap in the switch body by inserting the cap pins into the metallic retainer and push the cap into the switch body.

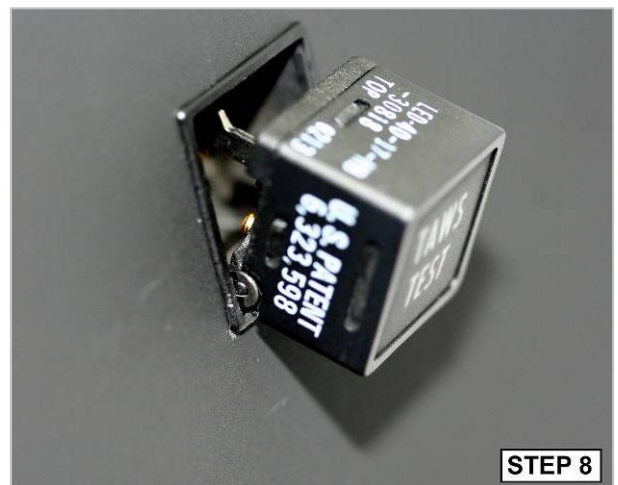

Appendix D

D. WIRING DIAGRAMS

This chart is a list of all MDL Rev R drawings in order of appearance.

DRAWING#	LEVEL	TITLE	REV	DATE
ETM407-001 Sht 1	SYSTEM COMPONENTS	TOP ASSY	A	11/5/20
ETM407-001 Sht 2	SYSTEM COMPONENTS	-1 CONFIGURATION	A	11/5/20
ETM407-001 Sht 3	SYSTEM COMPONENTS	-2 CONFIGURATION	A	11/5/20
ETM407-001 Sht 4	SYSTEM COMPONENTS	CABLE ROUTING	NC	5/13/16
ETM407-002 Sht 1	MECHANICAL INSTALL	LRU MOUNTING	NC	5/13/16
ETM407-002 Sht 2	MECHANICAL INSTALL	AIRSPEED SWITCH	NC	5/13/16
ETM407-002 Sht 3	MECHANICAL INSTALL	AIRSPEED SWITCH	NC	5/13/16
ETM407-002 Sht 4**	MECHANICAL INSTALL	AIRSPEED SWITCH	NC	5/13/16
ETM407-002 Sht 5	MECHANICAL INSTALL	PUSHBUTTON / INDICATOR	NC	5/13/16
ETM407-002 Sht 6	MECHANICAL INSTALL	OAT SENSOR	A	11/5/20
ETM407-003 Sht 1	WIRING INSTALLATION	POWER	NC	5/13/16
ETM407-003 Sht 2	WIRING INSTALLATION	THERMOUCOUPLE	A	11/5/20
ETM407-003 Sht 3	WIRING INSTALLATION	TORQUE	NC	5/13/16
ETM407-003 Sht 4	WIRING INSTALLATION	N1 GAS GENERATOR	NC	5/13/16
ETM407-003 Sht 5	WIRING INSTALLATION	N2 POWER TURBINE	NC	5/13/16
ETM407-003 Sht 6	WIRING INSTALLATION	NR ROTOR	NC	5/13/16
ETM407-003 Sht 7	WIRING INSTALLATION	AIRSPEED SWITCH	NC	5/13/16
ETM407-003 Sht 8	WIRING INSTALLATION	W.O.G SWITCH	NC	5/13/16
ETM407-003 Sht 9	WIRING INSTALLATION	AUDIO PANEL INTERFACE	NC	5/13/16
ETM407-003 Sht 10	WIRING INSTALLATION	OAT SENSOR	NC	5/13/16
ETM407-003 Sht 11	WIRING INSTALLATION	PUSHBUTTON / INDICATOR	NC	5/13/16
ETM407-003 Sht 12	WIRING INSTALLATION	LOAD CELL	NC	1/1/25
ETM407-004 Sht 1	WIRING INSTALLATION	-1 WIRE HARNESS	B	1/1/25
ETM407-004 Sht 2	WIRING INSTALLATION	-2 WIRE HARNESS	B	1/1/25
ETM407-005 Sht 1**	WIRING INSTALLATION	MAIN BOARD	B	1/1/25
ETM407-005 Sht 2**	WIRING ASSY	POWER SUPPLY BOARD	A	3/6/18
ETM407-005 Sht 3	WIRING ASSY	J1 PINOUT	B	1/1/25
ETM407-010 Sht 1	WIRING INSTALLATION	CONFIGURATION PORT	A	3/6/18
ETM407-011 Sht 1	WIRING INSTALLATION	DATA PORT	B	1/1/25

** Drawings not supplied to installer

ETM407-001 Sht 1 – TOP ASSEMBLY

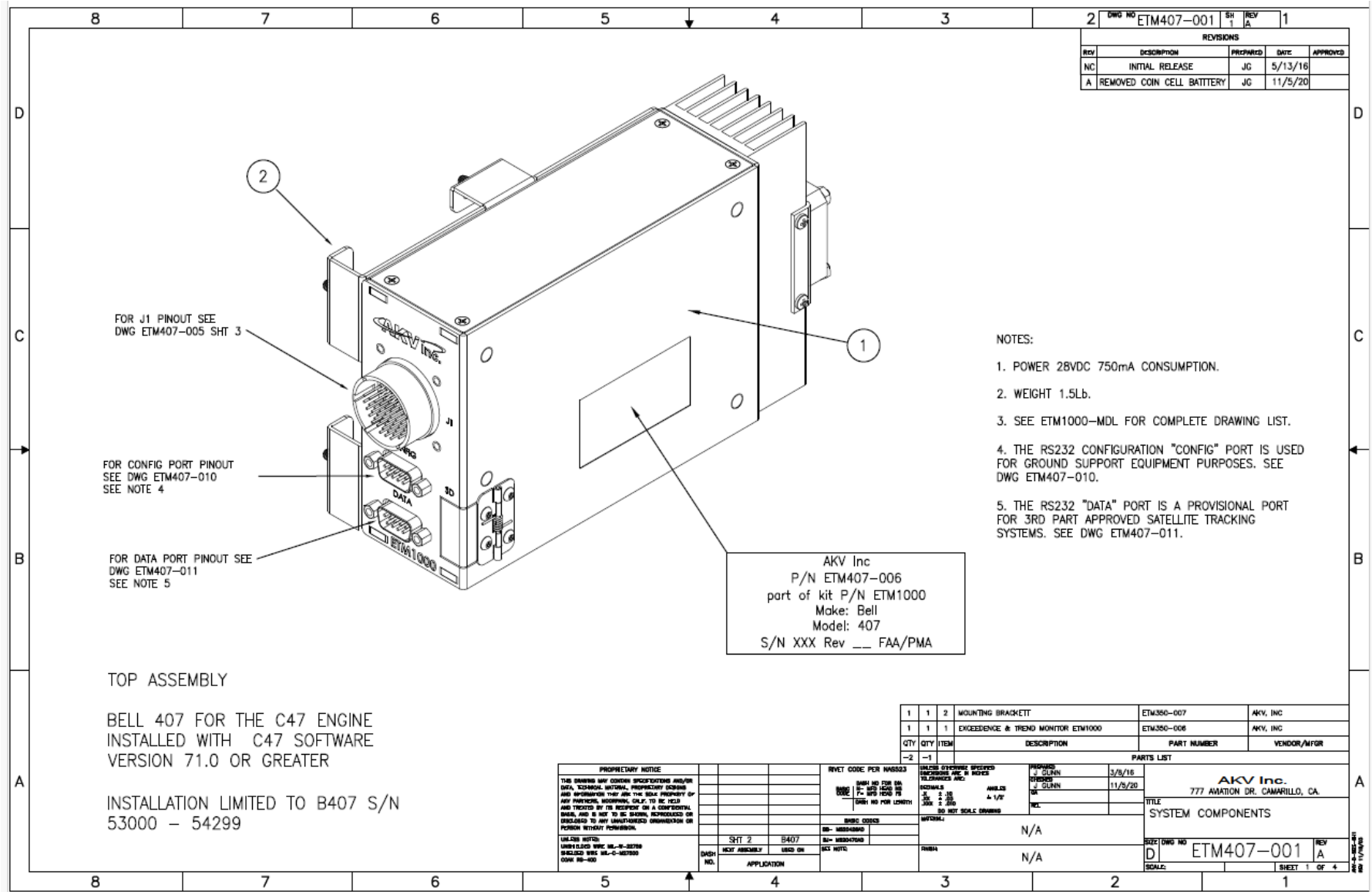

REVISIONS				
REV	DESCRIPTION	PREPARED	DATE	APPROVED
NC	INITIAL RELEASE	JG	5/13/16	
A	REMOVED COIN CELL BATTERY	JG	11/5/20	

- NOTES:
1. POWER 28VDC 750mA CONSUMPTION.
 2. WEIGHT 1.5Lb.
 3. SEE ETM1000-MDL FOR COMPLETE DRAWING LIST.
 4. THE RS232 CONFIGURATION "CONFIG" PORT IS USED FOR GROUND SUPPORT EQUIPMENT PURPOSES. SEE DWG ETM407-010.
 5. THE RS232 "DATA" PORT IS A PROVISIONAL PORT FOR 3RD PART APPROVED SATELLITE TRACKING SYSTEMS. SEE DWG ETM407-011.

AKV Inc
 P/N ETM407-006
 part of kit P/N ETM1000
 Make: Bell
 Model: 407
 S/N XXX Rev ___ FAA/PMA

TOP ASSEMBLY
 BELL 407 FOR THE C47 ENGINE
 INSTALLED WITH C47 SOFTWARE
 VERSION 71.0 OR GREATER
 INSTALLATION LIMITED TO B407 S/N
 53000 - 54299

QTY	ITEM	DESCRIPTION	PART NUMBER	VENDOR/MFR
1	1	MOUNTING BRACKET	ETM350-007	AKV, INC
1	1	EXCEEDENCE & TREND MONITOR ETM1000	ETM350-006	AKV, INC
-2	-1			

PROPRIETARY NOTICE		RYCET CODE PER PAS553		UNLESS OTHERWISE SPECIFIED		PROPOSED	
THIS DRAWING AND ANY OTHER SPECIFICATIONS AND/OR DATA, INCLUDING MATERIAL, PROPRIETARY DESIGN AND INFORMATION THEREON, ARE THE SOLE PROPERTY OF AKV, INC. AND ARE TO BE KEPT IN CONFIDENTIALITY. ANY REPRODUCTION, DISSEMINATION, OR USE OF THIS DRAWING OR INFORMATION THEREON WITHOUT THE WRITTEN PERMISSION OF AKV, INC. IS STRICTLY PROHIBITED.		SHEET NO. 2 OF 2		DATE: 3/5/16		3/5/16	
UNLESS NOTED OTHERWISE, ALL DIMENSIONS ARE IN INCHES UNLESS OTHERWISE SPECIFIED.		SHEET NO. 2 OF 2		DATE: 11/5/20		11/5/20	
DASH NO. 001		SHEET NO. 2 OF 2		DATE: 11/5/20		11/5/20	
APPLICATION		SHEET NO. 2 OF 2		DATE: 11/5/20		11/5/20	

SIZE	DWG NO	REV
D	ETM407-001	A

ETM407-001 Sht 2 – -1 CONFIGURATION

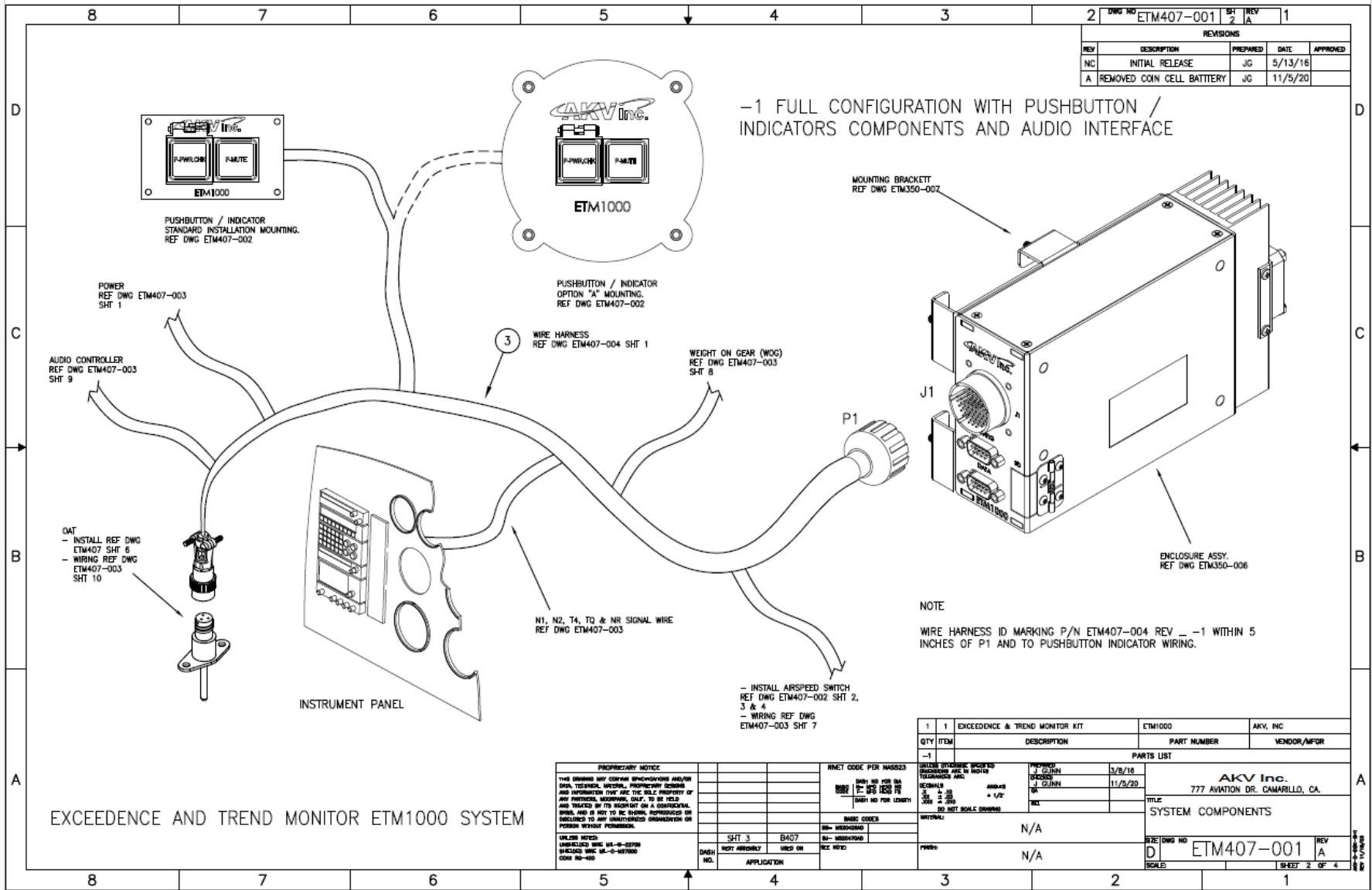

ETM407-001 Sht 3 – - 2 CONFIGURATION

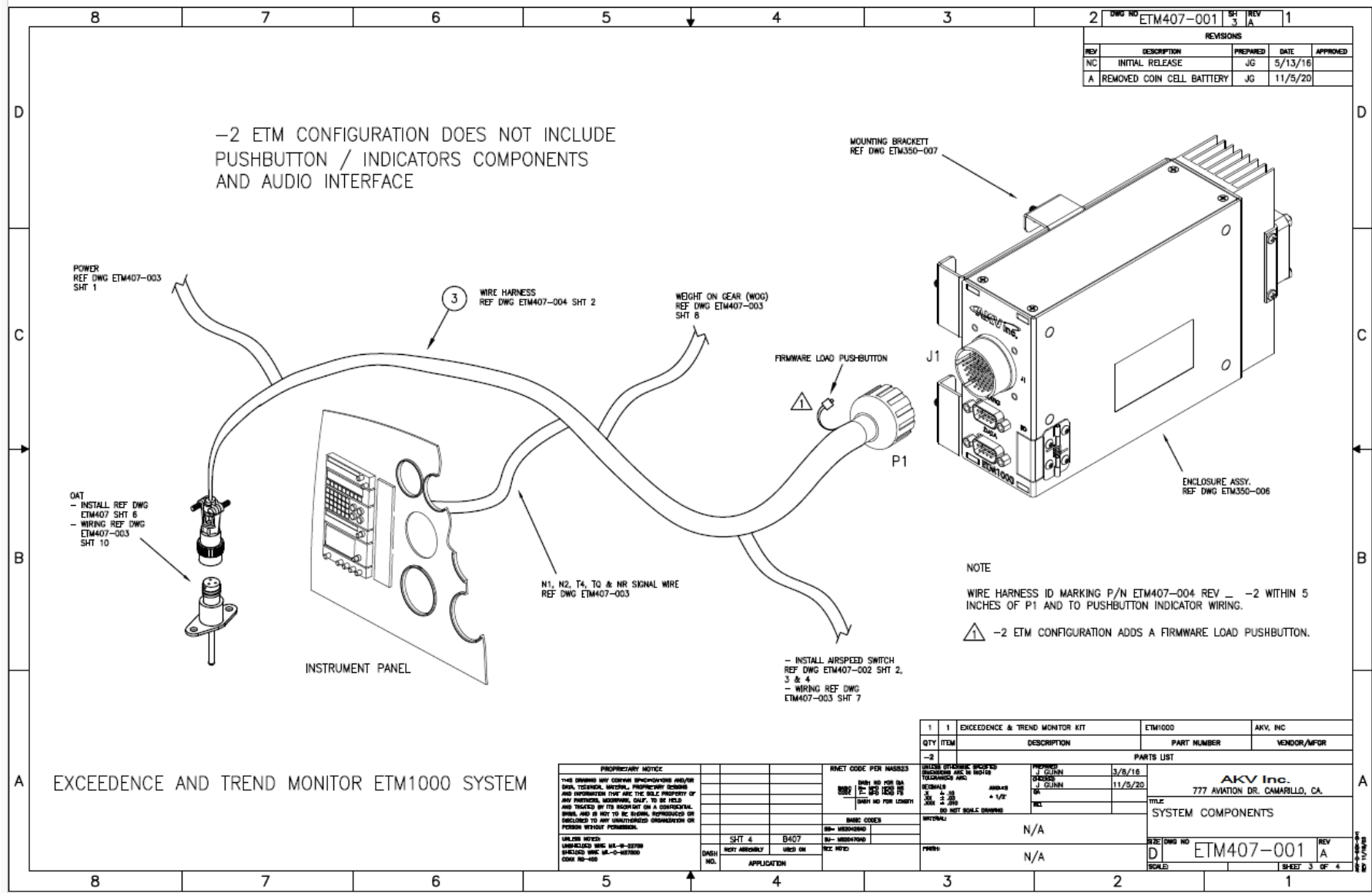

ETM407-001 Sht 4 – CABLE ROUTING

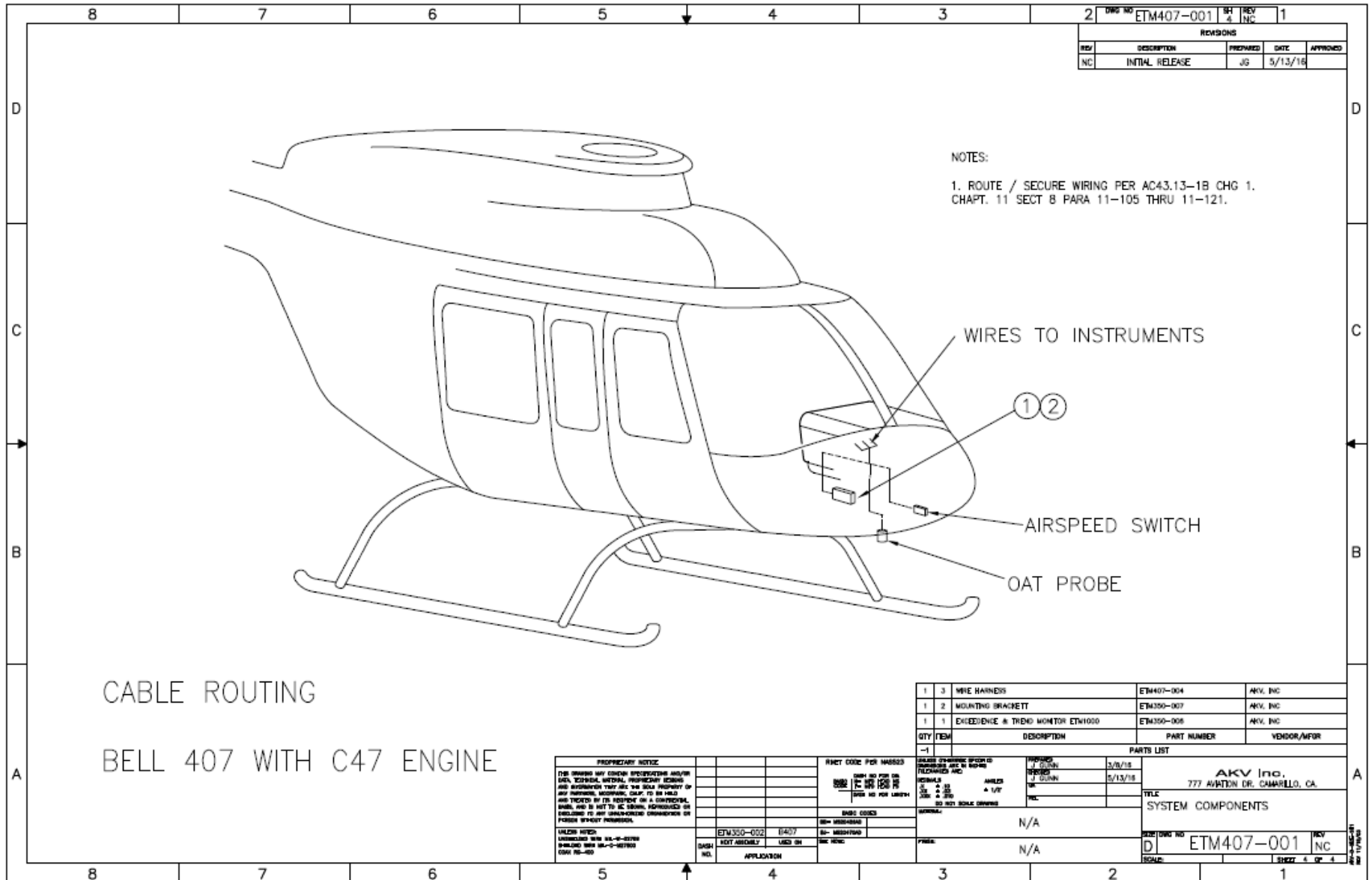

ETM407-002 Sht 1 – LRU MOUNTING

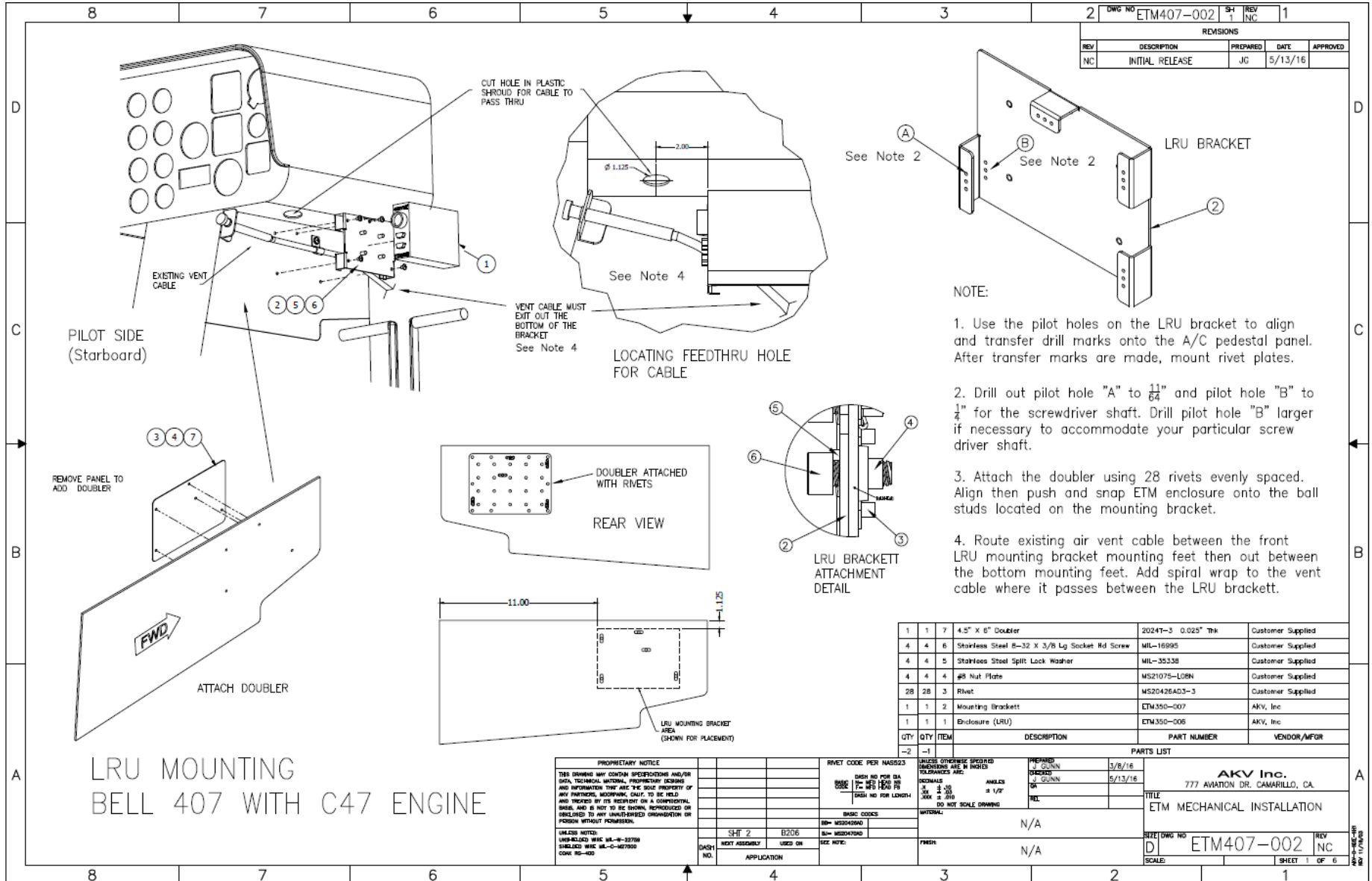

ETM407-002 Sht 2 – AIRSPEED SWITCH

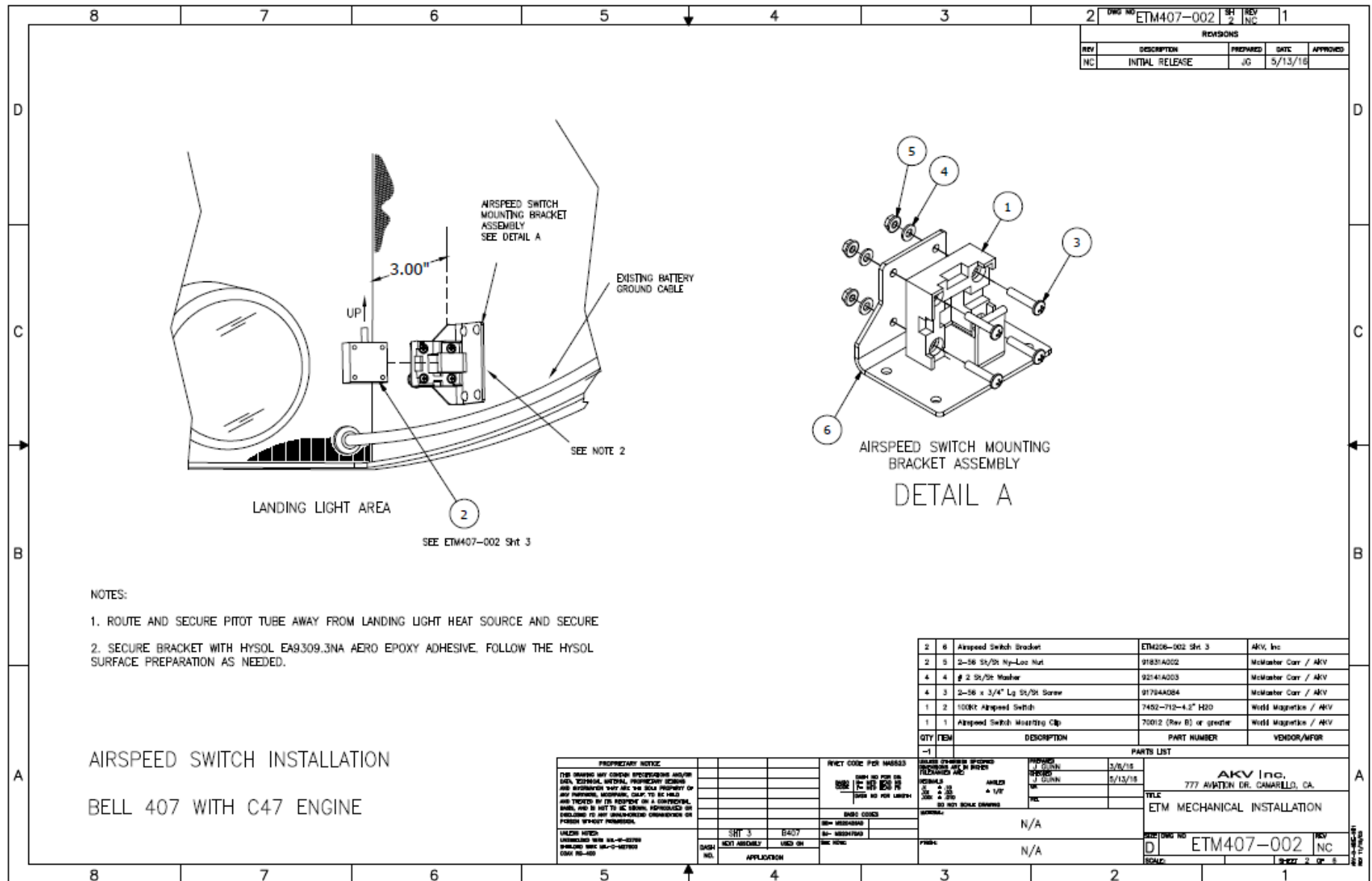

ETM407-002 Sht 3 – AIRSPEED SWITCH

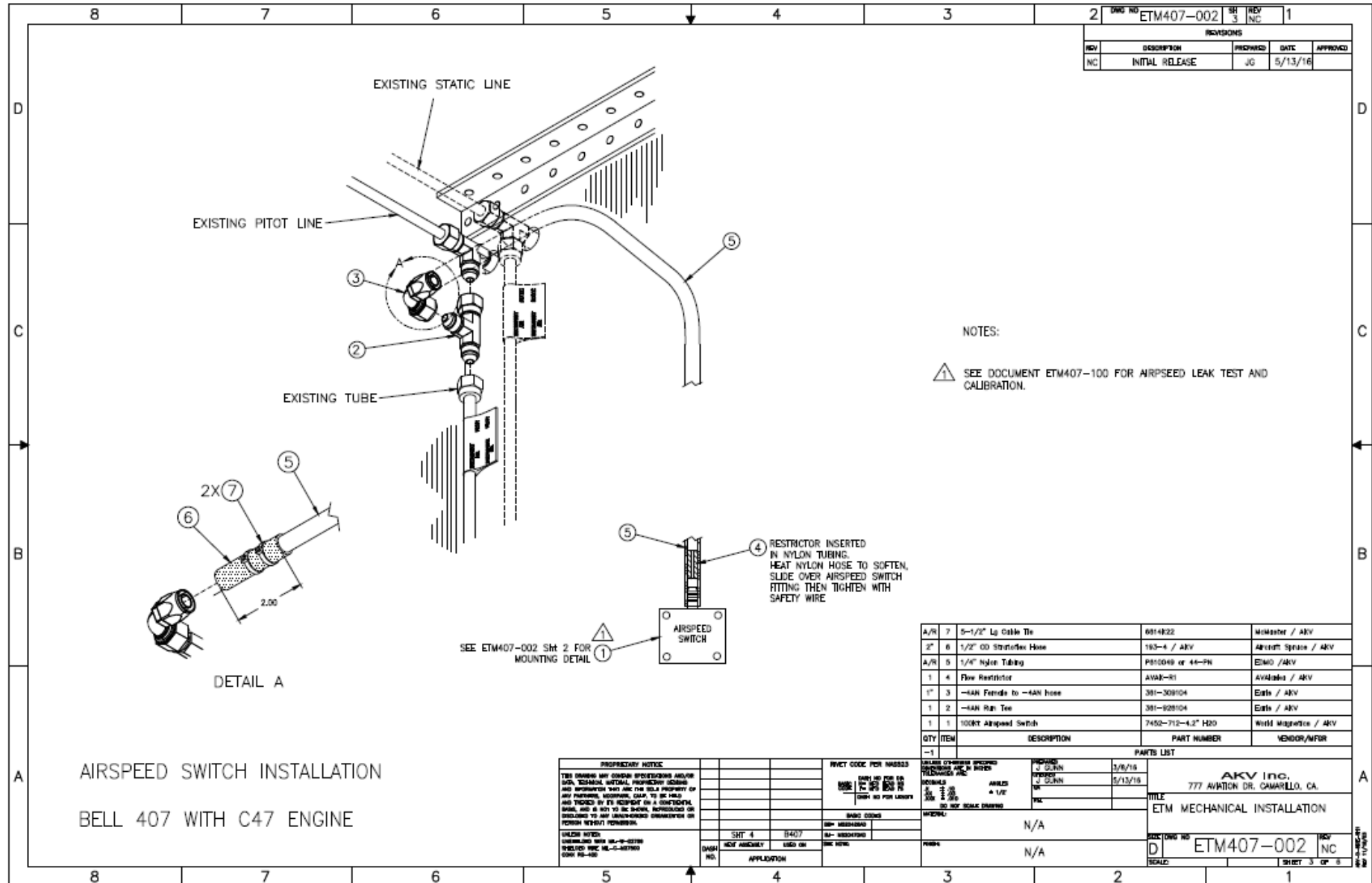

ETM407-002 Sht 4 – AIRSPEED SWITCH

**Drawing Not Supplied
To Installer**

ETM407-003 Sht 1 - POWER

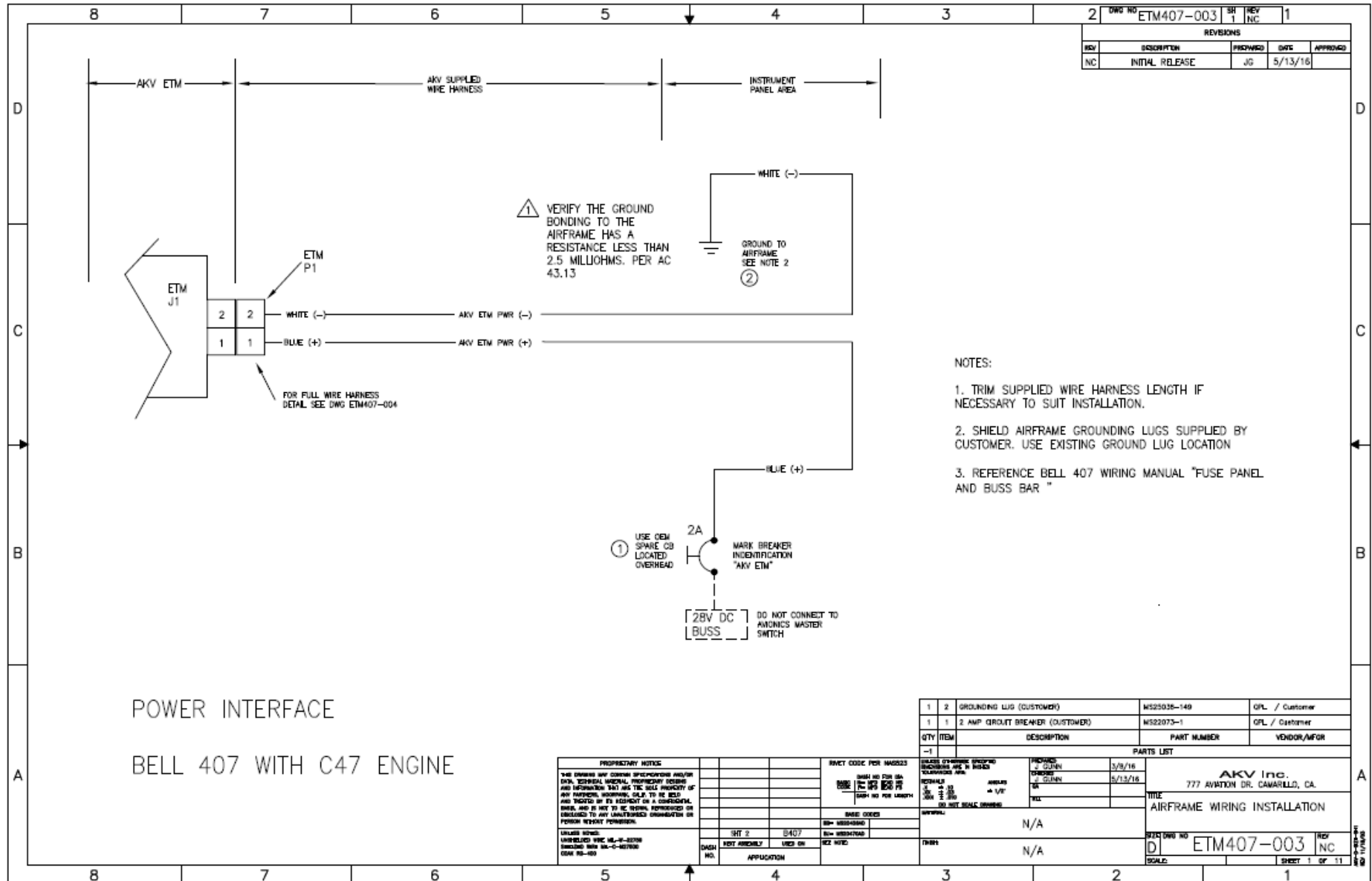

ETM407-003 Sht 2 – THERMOUCOUPLE

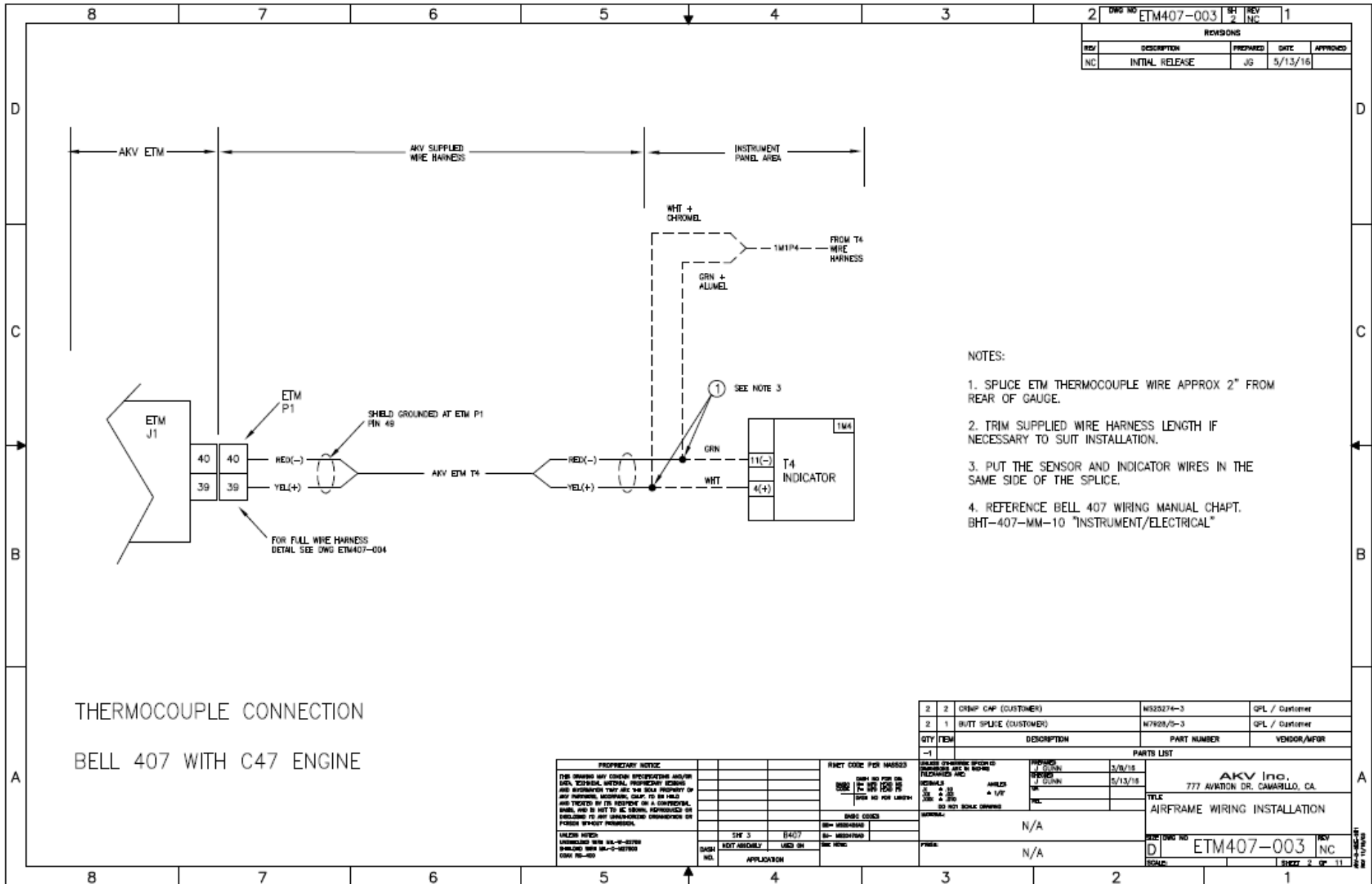

REV	DESCRIPTION	PREPARED	DATE	APPROVED
NC	INITIAL RELEASE	JG	5/13/16	

- NOTES:
1. SPLICE ETM THERMOUCOUPLE WIRE APPROX 2" FROM REAR OF GAUGE.
 2. TRIM SUPPLIED WIRE HARNESS LENGTH IF NECESSARY TO SUIT INSTALLATION.
 3. PUT THE SENSOR AND INDICATOR WIRES IN THE SAME SIDE OF THE SPLICE.
 4. REFERENCE BELL 407 WIRING MANUAL CHAPT. BHT-407-MM-10 "INSTRUMENT/ELECTRICAL"

THERMOUCOUPLE CONNECTION
 BELL 407 WITH C47 ENGINE

QTY	ITEM	DESCRIPTION	PART NUMBER	VENDOR/AFOR
2	2	ORNP CAP (CUSTOMER)	N53274-3	QPL / Customer
2	1	BUTT SPLICE (CUSTOMER)	N7928/5-3	QPL / Customer

REV	DESCRIPTION	DATE	BY	CHKD
1	INITIAL RELEASE	5/13/16	JG	

AKV Inc. 777 AVIATION DR. CAMARILLO, CA
TITLE AIRFRAME WIRING INSTALLATION
REV D
ETM407-003
REV NC
SHEET 2 OF 11

ETM407-003 Sht 4 – N1 GAS GENERATOR

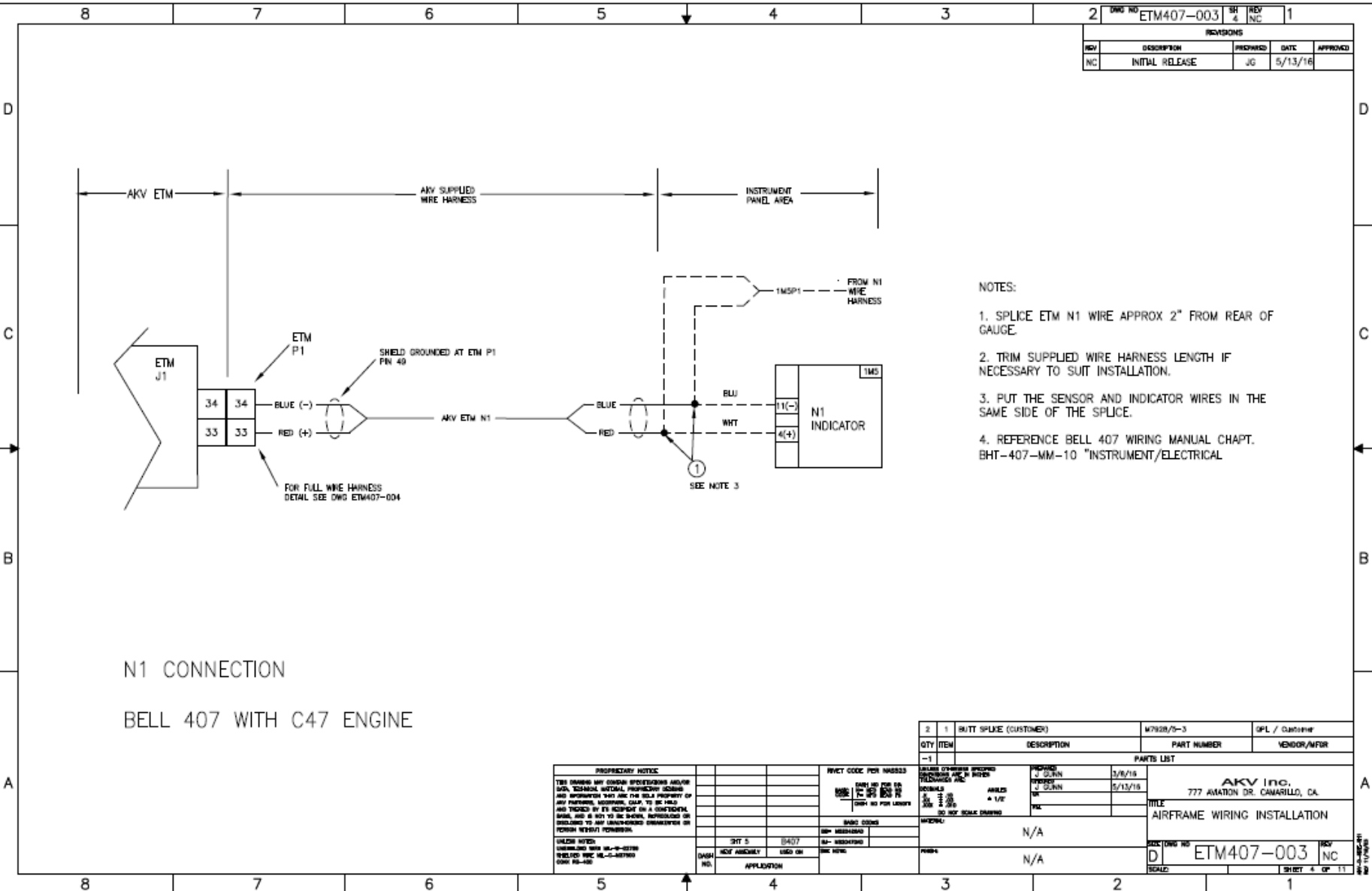

2	DWG NO	ETM407-003	REV	NC	1
REVISIONS					
REV	DESCRIPTION	PROVISED	DATE	APPROVED	
NC	INITIAL RELEASE	JG	5/13/16		

- NOTES:
1. SPLICE ETM N1 WIRE APPROX 2" FROM REAR OF GAUGE.
 2. TRIM SUPPLIED WIRE HARNESS LENGTH IF NECESSARY TO SUIT INSTALLATION.
 3. PUT THE SENSOR AND INDICATOR WIRES IN THE SAME SIDE OF THE SPLICE.
 4. REFERENCE BELL 407 WIRING MANUAL CHAPT. BHT-407-MM-10 "INSTRUMENT/ELECTRICAL"

N1 CONNECTION
 BELL 407 WITH C47 ENGINE

PROPRIETARY NOTICE
 THIS DRAWING AND OTHER SPECIFICATIONS HEREOF ARE THE SOLE PROPERTY OF AKV, INC. AND ARE NOT TO BE REPRODUCED OR TRANSMITTED IN ANY FORM OR BY ANY MEANS, ELECTRONIC OR MECHANICAL, INCLUDING PHOTOCOPYING, RECORDING, OR BY ANY INFORMATION STORAGE AND RETRIEVAL SYSTEM, WITHOUT THE WRITTEN PERMISSION OF AKV, INC.
 UNLESS NOTED OTHERWISE, THIS DRAWING IS UNCLASSIFIED AND IS NOT TO BE CONTROLLED BY ITAR.
 UNLESS NOTED OTHERWISE, THIS DRAWING IS UNCLASSIFIED AND IS NOT TO BE CONTROLLED BY ITAR.

REV	DATE	DESCRIPTION
001	0407	ISSUE FOR PRODUCTION
002	0513	REVISED PER REV C

2	1	BUTT SPLICE (CUSTOMER)	M7928/2-3	QPL / Customer
QTY	ITEM	DESCRIPTION	PART NUMBER	VENDOR/MFR
-1				
PARTS LIST				
REVISED BY		J. GUNN	DATE	3/6/16
APPROVED BY		J. GUNN	DATE	5/13/16
SCALE		AS SHOWN		
TOLERANCES UNLESS OTHERWISE SPECIFIED		FRACTIONS: 1/16, 1/8, 1/4, 1/2, 3/4, 1, 2, 3, 4, 5, 6, 8, 10, 12, 16, 20, 24, 30, 36, 48, 60, 72, 96, 120, 144, 180, 240, 300, 360, 480, 600, 720, 960, 1200		
DIMENSIONS UNLESS OTHERWISE SPECIFIED		INCHES: .0005, .001, .002, .005, .010, .015, .020, .030, .040, .050, .060, .070, .080, .090, .100, .125, .150, .175, .200, .250, .300, .375, .500, .625, .750, .875, 1.000, 1.250, 1.500, 1.750, 2.000, 2.500, 3.000, 3.500, 4.000, 4.500, 5.000, 5.500, 6.000, 6.500, 7.000, 7.500, 8.000, 8.500, 9.000, 9.500, 10.000		
MATERIALS UNLESS OTHERWISE SPECIFIED		N/A		
FINISH UNLESS OTHERWISE SPECIFIED		N/A		
DRAWN BY		N/A		
CHECKED BY		N/A		
DATE		N/A		
SCALE		N/A		
SHEET		4 OF 11		

AKV Inc.
 777 AVIATION DR. CAMARILLO, CA.

TITLE: AIRFRAME WIRING INSTALLATION

SIZE (DWG NO): D (ETM407-003) REV: NC

ETM407-003 Sht 5 – N2 POWER TURBINE

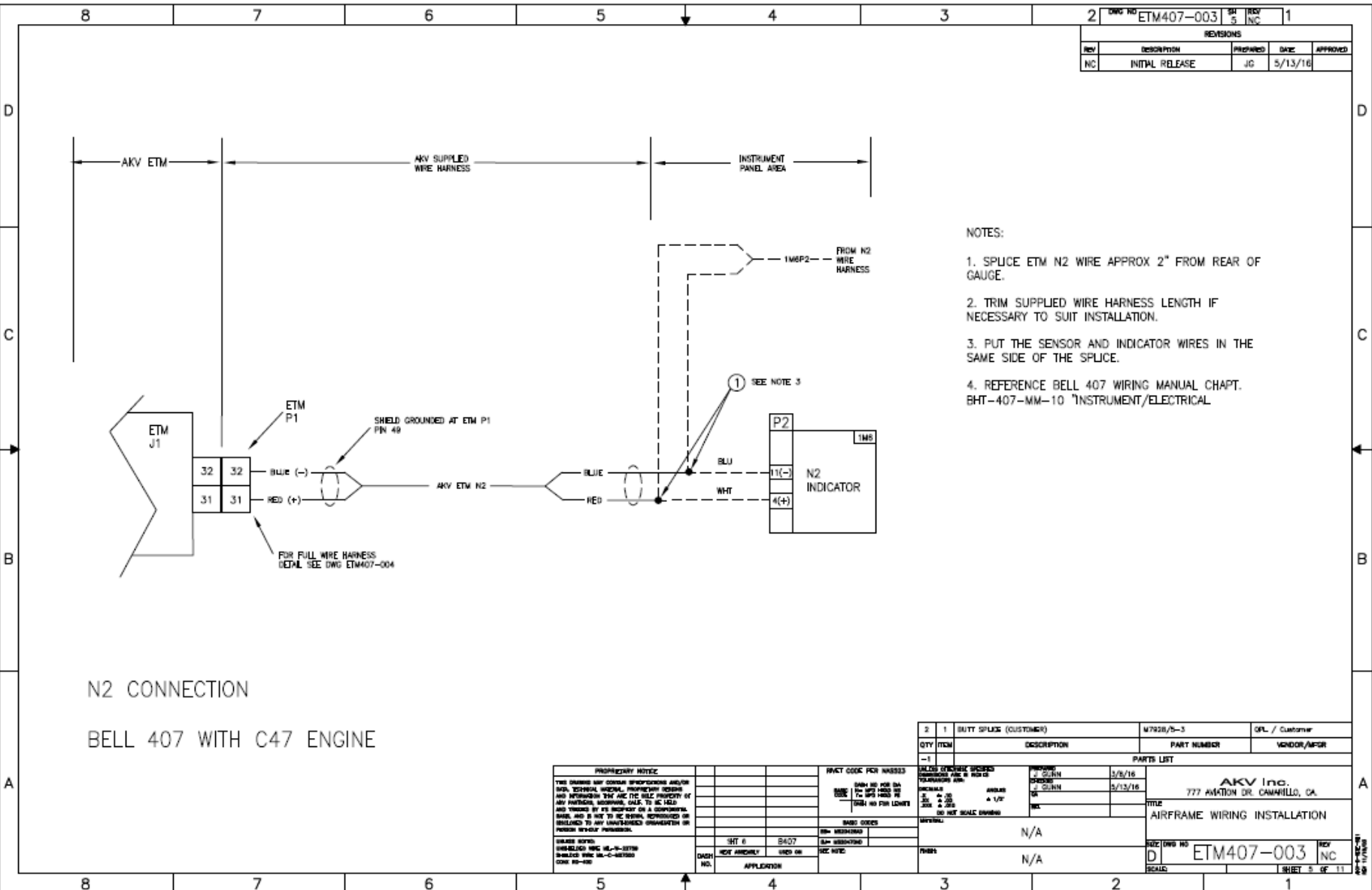

REVISIONS				
REV	DESCRIPTION	PREPARED	DATE	APPROVED
NC	INITIAL RELEASE	JG	5/13/16	

- NOTES:
1. SPLICE ETM N2 WIRE APPROX 2" FROM REAR OF GAUGE.
 2. TRIM SUPPLIED WIRE HARNESS LENGTH IF NECESSARY TO SUIT INSTALLATION.
 3. PUT THE SENSOR AND INDICATOR WIRES IN THE SAME SIDE OF THE SPLICE.
 4. REFERENCE BELL 407 WIRING MANUAL CHAPT. BHT-407-MM-10 INSTRUMENT/ELECTRICAL

N2 CONNECTION
 BELL 407 WITH C47 ENGINE

PROPRIETARY NOTICE		PRINT CODE FOR AIRBSS		BLAS EXCLUDED SYSTEMS		PARTS LIST	
THIS DRAWING MAY CONTAIN INFORMATION AND/OR DATA, TECHNICAL, PROPRIETARY, DESIGN AND INFORMATION THAT ARE THE SOLE PROPERTY OF AKV INCORPORATED. THIS DRAWING IS TO BE USED ONLY FOR THE PURPOSES AND TERMS OF ITS ISSUANCE OR A CONTRACT. THIS DRAWING IS NOT TO BE REPRODUCED OR TRANSMITTED IN ANY FORM OR BY ANY MEANS, ELECTRONIC OR MECHANICAL, INCLUDING PHOTOCOPYING, RECORDING, OR BY ANY INFORMATION STORAGE AND RETRIEVAL SYSTEM, WITHOUT THE WRITTEN PERMISSION OF AKV INCORPORATED.		DRAWING AND/OR DATA TO BE USED FOR: []		REVISIONS: []		DATE: 3/5/16	
DATE: 3/5/16		REV: 5		REV: NC		REV: NC	
DRAWN BY: []		CHKD BY: []		APP'D BY: []		DATE: 3/5/16	
SHEET NO. 5		SHEET TOTAL 11		REV: NC		REV: NC	

2	1	BUTT SPLICE (CUSTOMER)	M7928/B-3	QPL / Customer
QTY	ITEM	DESCRIPTION	PART NUMBER	VENDOR/AOR
-1				
AKV Inc. 777 AVIATION DR. CARMILLO, CA.				
AIRFRAME WIRING INSTALLATION				
REV: D				
ETM407-003				
REV: NC				
SHEET 5 OF 11				

ETM407-003 Sht 6 – NR ROTOR

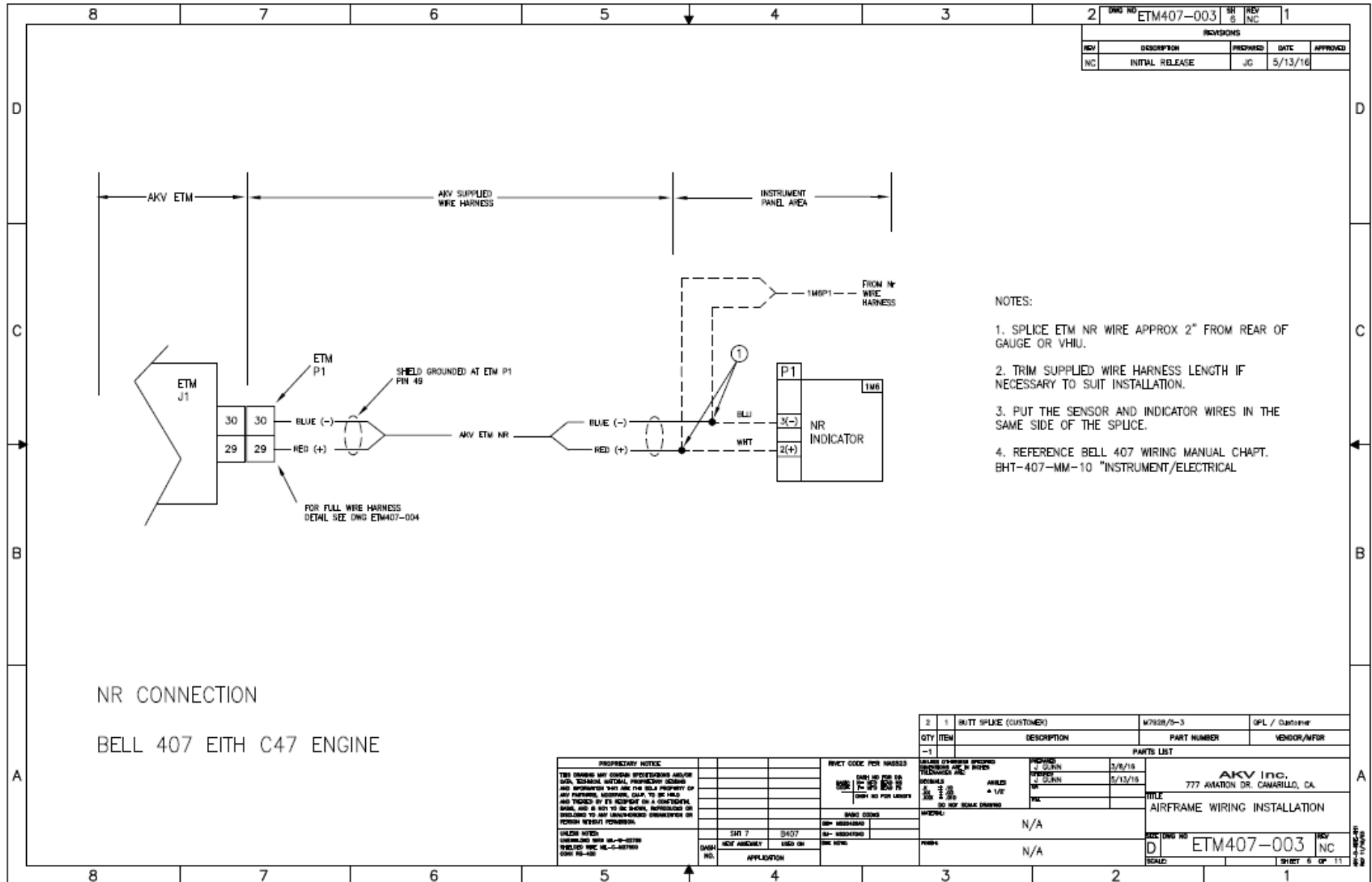

REVISIONS				
REV	DESCRIPTION	PROWID	DATE	APPROVED
NC	INITIAL RELEASE	JG	5/13/16	

NOTES:

1. SPLICE ETM NR WIRE APPROX 2" FROM REAR OF GAUGE OR VHIU.
2. TRIM SUPPLIED WIRE HARNESS LENGTH IF NECESSARY TO SUIT INSTALLATION.
3. PUT THE SENSOR AND INDICATOR WIRES IN THE SAME SIDE OF THE SPLICE.
4. REFERENCE BELL 407 WIRING MANUAL CHAPT. BHT-407-MM-10 "INSTRUMENT/ELECTRICAL"

QTY	ITEM	DESCRIPTION	PART NUMBER	VENDOR/MFR
-1		BUTT SPLICE (CUSTOMER)	W7928/5-3	GPL / Customer

PROPRIETARY NOTICE		REVCT CODE PER NAS823		REVISED BY		DATE	
THIS DRAWING AND ALL INFORMATION CONTAINED HEREIN ARE THE PROPERTY OF AKV, INC. AND ARE NOT TO BE DISCLOSED OR REPRODUCED IN ANY MANNER WITHOUT THE WRITTEN PERMISSION OF AKV, INC.		DATE FOR SALES: 5/13/16		REVISED BY: JG		DATE: 5/13/16	
UNLESS NOTED OTHERWISE THIS DRAWING IS UNCLASSIFIED AND IS NOT TO BE DISCLOSED OR REPRODUCED IN ANY MANNER WITHOUT THE WRITTEN PERMISSION OF AKV, INC.		DATE FOR LEGAL: 5/13/16		REVISED BY: JG		DATE: 5/13/16	
UNLESS NOTED OTHERWISE THIS DRAWING IS UNCLASSIFIED AND IS NOT TO BE DISCLOSED OR REPRODUCED IN ANY MANNER WITHOUT THE WRITTEN PERMISSION OF AKV, INC.		DATE FOR LEGAL: 5/13/16		REVISED BY: JG		DATE: 5/13/16	

DASH NO.	REV	ASSEMBLY	USED ON	REV	DATE
	SHT 7	3407			

PARTS LIST		TITLE		SCALE	
N/A		AIRFRAME WIRING INSTALLATION		1:1	
N/A		AKV Inc. 777 AMATION DR. CAMARILLO, CA		D	
N/A		ETM407-003		REV NC	
N/A		SHEET 6 OF 11			

ETM407-003 Sht 8 – W.O.G SWITCH

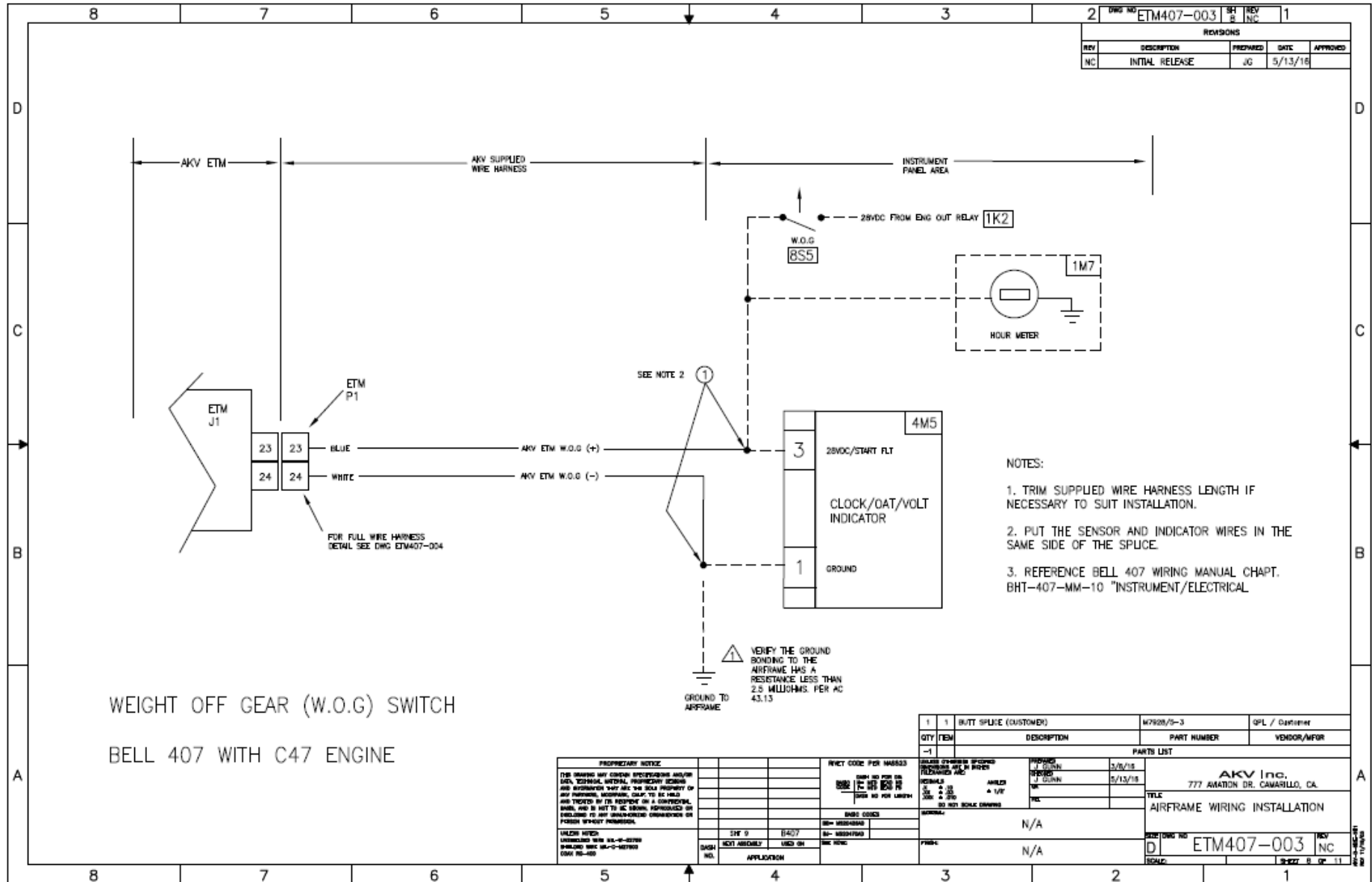

ETM407-003 Sht 10 - OAT SENSOR

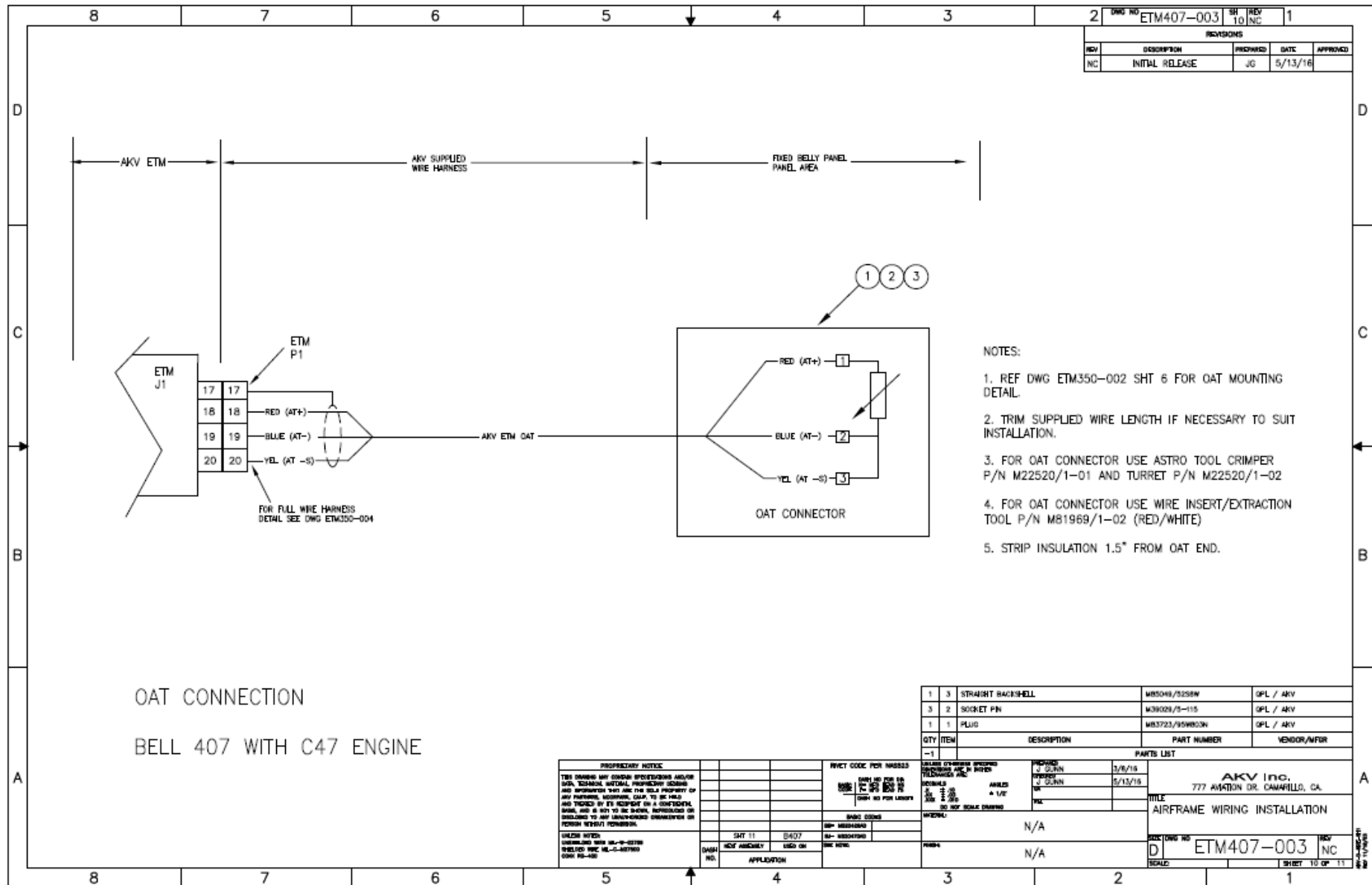

ETM407-003 Sht 11 – PUSHBUTTON / INDICATOR

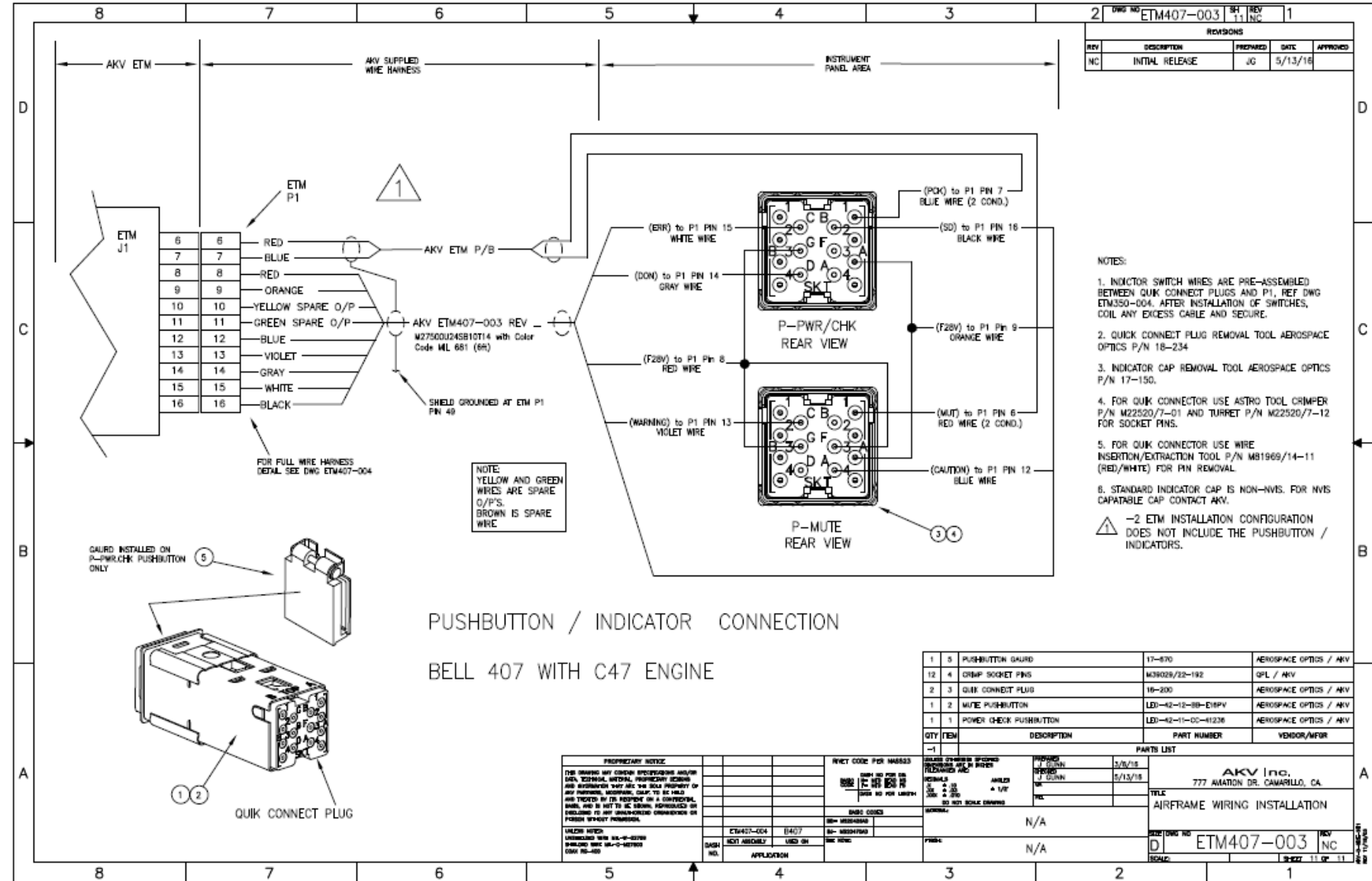

ETM407-003 Sht 12 – LOAD CELL

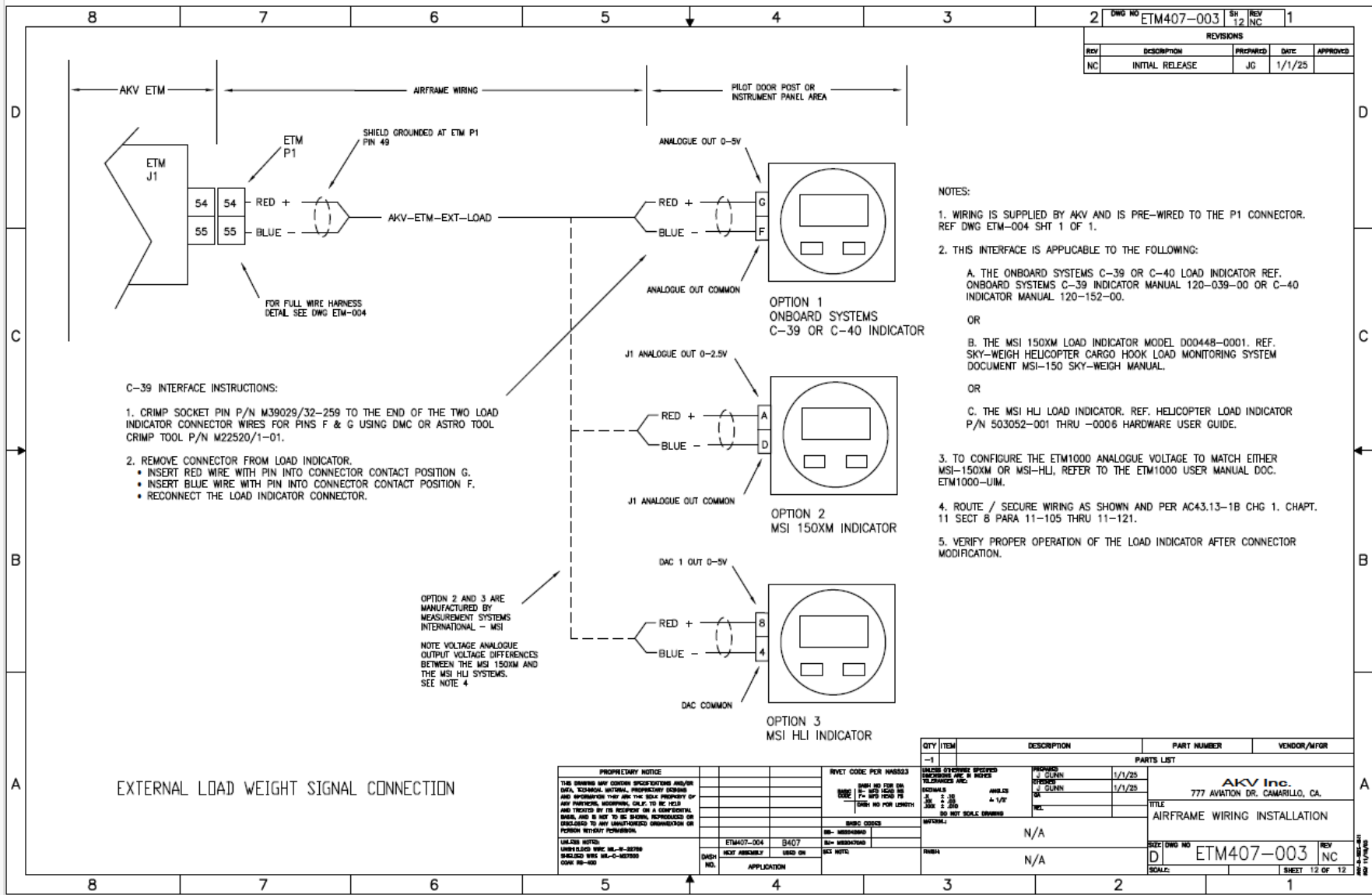

ETM407-004 Sht 1 - -1 WIRE HARNESS

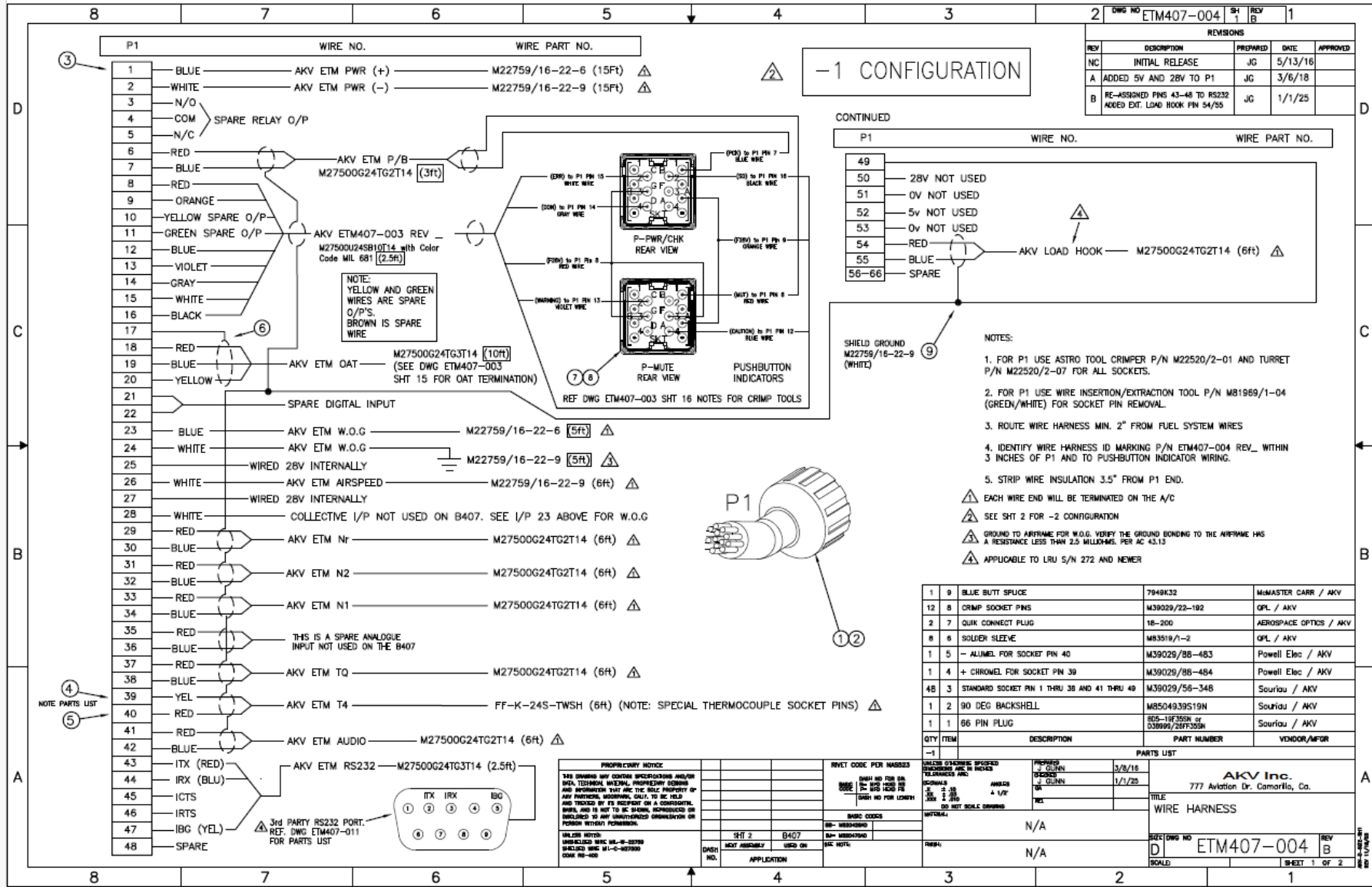

ETM407-004 Sht 2 - -2 WIRE HARNESS

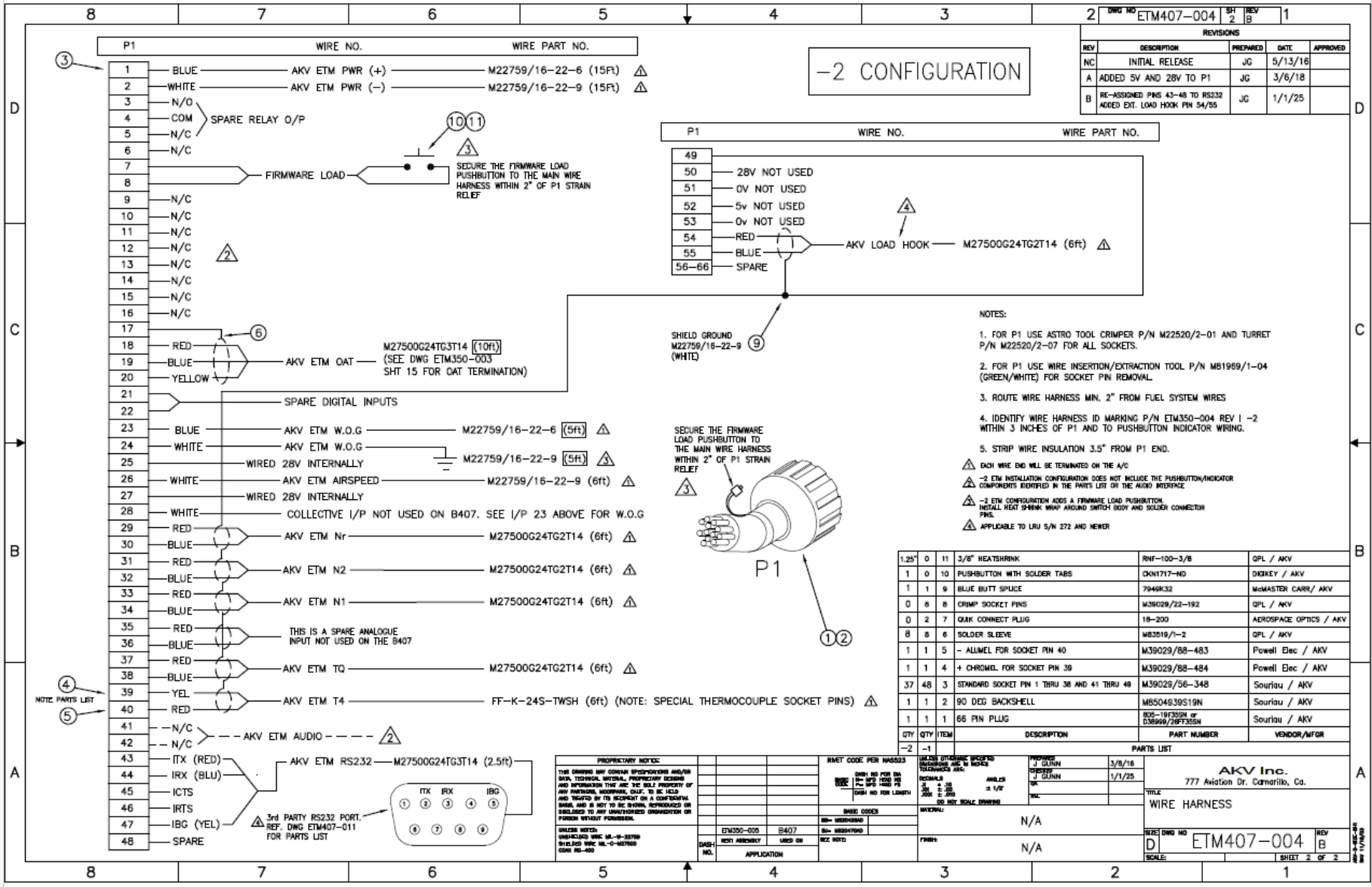

ETM407-005 Sht 1 – MAIN BOARD

**Drawing Not Supplied
To Installer**

ETM407-005 Sht 2 – POWER SUPPLY BOARD

**Drawing Not Supplied
To Installer**

ETM407-010 Sht 1 – CONFIGURATION PORT

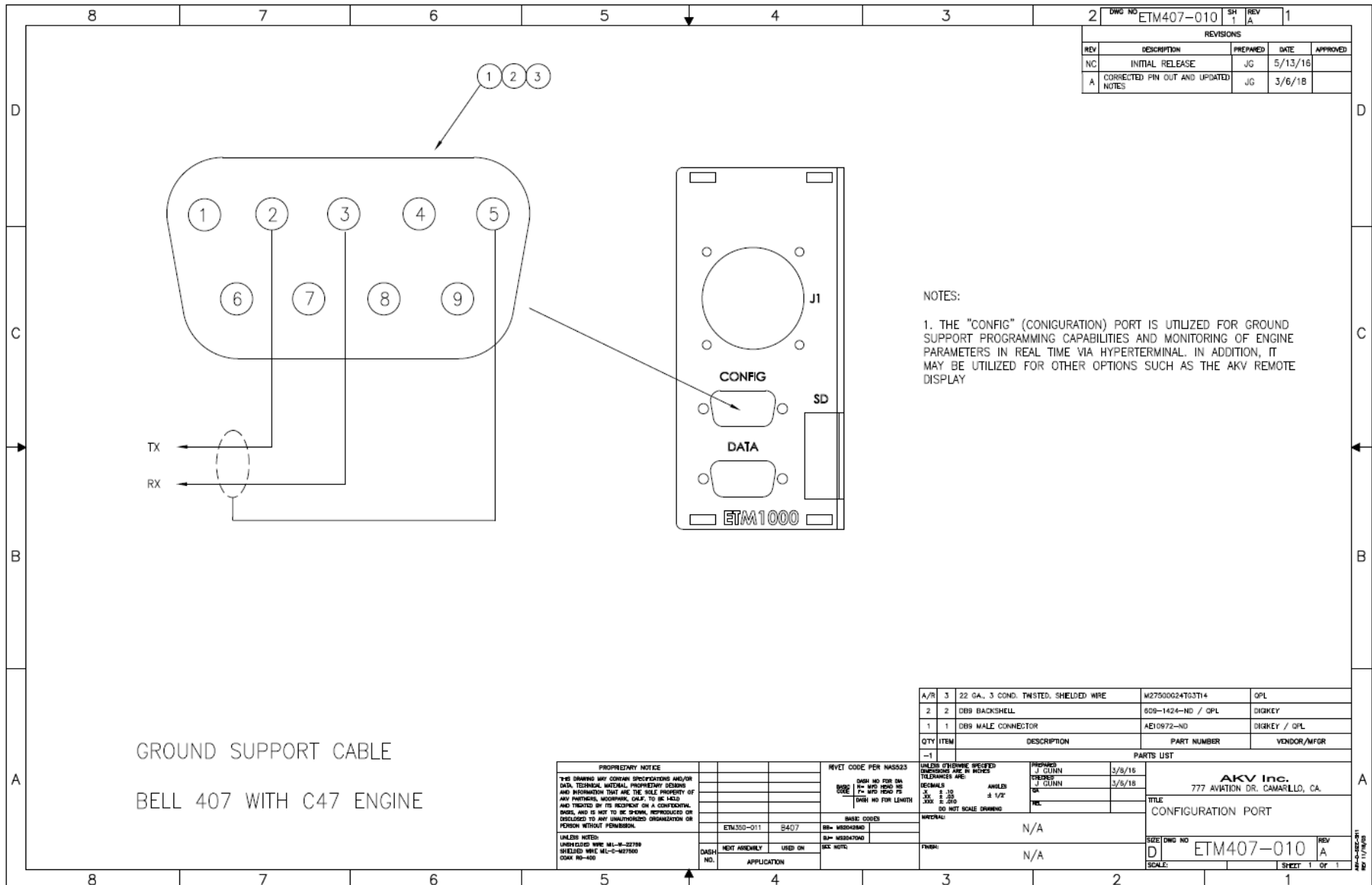

ETM407-011 Sht 1 – DATA PORT

