

THE INFORMATION CONTAINED IN THIS DRAWING IS THE SOLE PROPERTY OF SAGE PRODUCT DEVELOPMENT, INC. ANY REPRODUCTION IN PART OR IN WHOLE WITHOUT THE WRITTEN PERMISSION OF SAGE PRODUCT DEVELOPMENT, INC. IS PROHIBITED.

REVISIONS	
REV.	DCO #
A	952
B	1002

ITEM NO.	PART NUMBER	DESCRIPTION	QTY.
1	230-09161-SPD	ETCHED PTFE 0.091" ID LINER	1
2	230-08771-09-SPD	SYMMETRY SY-034850 HYPOTUBE FR 9	1
3	230-09159-SPD	PEBAX 0.112" ID EXTRUSION	1

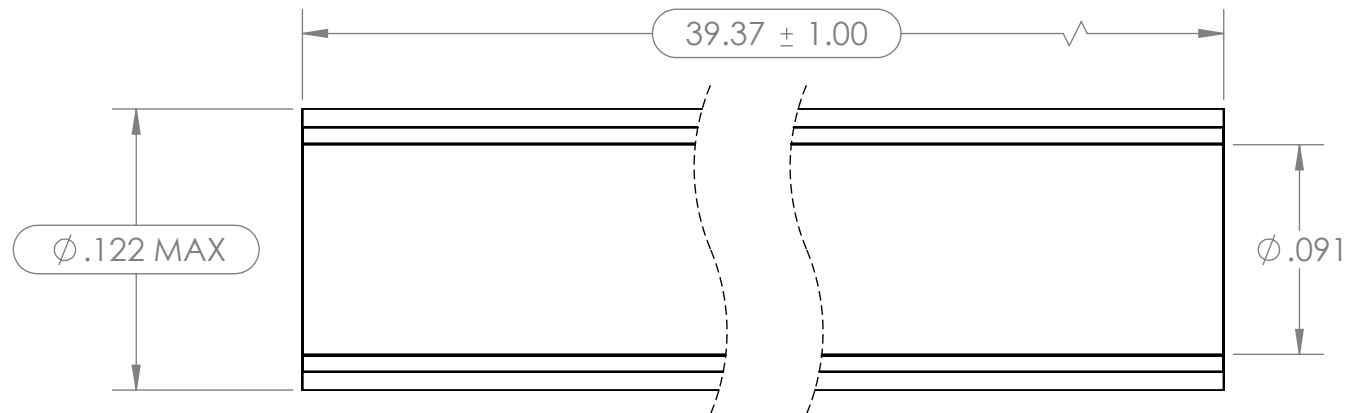
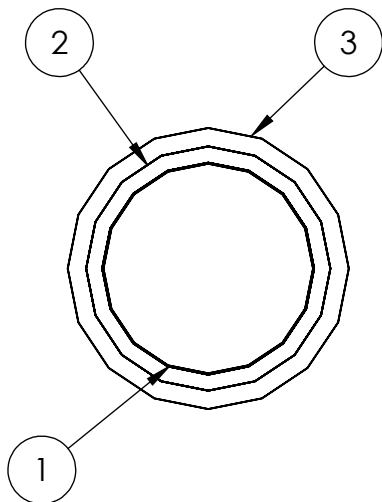

NOTES:

- LAMINATED CATHETER WITH A PTFE LINER, LASER CUT HYPOTUBE, AND PEBAX JACKET
- OVERHANG PAST 39.370" LENGTH NOT TO EXCEED 0.25" ON EITHER SIDE
- INSPECTION DIMENSIONS INDICATED BY (X.X)
- HAIRS OR FIBERS (TAPPI CHART):
  - 5 OR MORE EMBEDDED PARTICLES 0.8 MM<sup>2</sup> OR SMALLER
  - A PARTICLE 0.8 MM<sup>2</sup> OR LARGER

UNLESS OTHERWISE SPECIFIED  
DIMENSIONS ARE IN INCHES  
TOLERANCES ARE:  
INCHES [MM]  
.X ±0.02 .X ±0.5  
.XX ±0.01 .XX ±0.25  
.XXX ±0.005 .XXX ±0.127  
ANGLES: ±0.5°  
ANSI/ASME Y14.5M

MATERIAL:  
SEE NOTES

FINISH:  
SEE NOTES

DO NOT SCALE DRAWING



LAMINATED CATHETER 9FR

SIZE DWG. NO. **A** 260-09139-09-SPD

REV **B**

SCALE: 12:1

SHEET 1 OF 1