

AHD-WAOP / AHD-WAOP K
Watch Alarm Panel / Deadman System (BNWAS)



Operating Manual

Read the operating instructions before starting any work!



Doc ID: PaB-1098 V10

© Böning
Automation Technology GmbH & Co. KG
Am Steenöver 4
D-27777 Ganderkesee

Tel.: +49 (0) 4221 9475-0
Fax +49 (0) 4221 9475-21 /-22

Email: info@boening.com
Website: www.boening.com

1	General	7
1.1	Information about the operating instructions	7
1.2	Explanation of symbols.....	7
1.3	Limitation of Liability	8
1.4	Copyright protection	9
1.5	Spare parts.....	9
1.6	Warranty terms	9
1.7	Customer Care	9
2	Safety.....	10
2.1	Responsibility of the operator	10
2.2	Personnel requirements	11
2.2.1	Qualifications.....	11
2.2.2	Unauthorized persons.....	12
2.3	Intended use	12
3	Design and function	14
3.1	General function	14
3.2	AHD-WAOP (watch alarm panel).....	15
3.2.1	AHD-WAOP warning levels	16
3.2.2	External start-stop function - AHD-WAOP	18
3.3	AHD-WAOP K (deadman alarm system).....	19
3.3.1	AHD-WAOP K Warning levels.....	20
3.3.2	External start function - AHD-WAOP K.....	21
3.4	emergency power supply.....	22
3.5	Additional alarm and acknowledgment panels	22
3.6	Connection of a voyage data recorder	22
3.6.1	Protocol.....	23
3.8	AHD-WAOP SB.....	24
3.9	AHD-WAOP SA	24
3.10	AHD-WAOP SK.....	25
3.11	AHD-WAOP MD / AHD-WAOP MDA.....	26
4	Technical information	27
4.1	Technical data AHD-WAOP	27
4.1.1	Device dimensions AHD-WAOP.....	27
4.2	Technical data AHD-WAOP K	28
4.2.1	Device dimensions AHD-WAOP K.....	28
4.3	Technical data AHD-WAOP SB.....	29
4.3.1	Device dimensions AHD-WAOP SB	29
4.4	Technical data AHD-WAOP SA	30
4.4.1	Device dimensions AHD-WAOP SA.....	30

4.4.2	Device dimensions AHD-WAOP SA AP	31
4.5	Technical data AHD-WAOP SK	31
4.5.1	Device dimensions AHD-WAOP SK	32
4.5.2	Device dimensions AHD-WAOP SK AP	32
4.6	Technical data AHD-WAOP MD / AHD-WAOP MDA	33
4.6.1	Device dimensions AHD-WAOP MD / AHD-WAOP MDA	34
4.7	Connection terminals AHD-WAOP / AHD-WAOP K	35
4.8	Connection terminals AHD-WAOP MD / AHD-WAOP MDA	38
5	Application examples	39
6	Transport, packaging, and storage	43
6.1	Safety instructions for transport	43
6.2	Transport inspection	43
6.3	Packaging	43
7	Installation and initial commissioning	45
7.1	Safety	45
7.2	Installation	45
7.2.1	installation requirements	45
7.2.2	Installation of the devices	47
7.3	Initial startup of the	48
8	Operation	50
8.1	Switching on	50
8.2	Starting and stopping AHD-WAOP	51
8.3	Starting and stopping AHD-WAOP K	51
8.4	Acknowledging standby mode and alarms	51
8.5	Triggering an emergency call	52
8.6	Ending an emergency call	52
8.7	AHD-WAOP settings menu	52
8.8	Setting menu AHD-WAOP K	55
8.9	Automatic dimming	57
8.10	Switching off	57
9	Maintenance	57
10	Malfunctions	58
10.1	Safety	58
10.2	Fault LED	59
10.3	Troubleshooting	59

11	Disassembly.....	60
11.1	Safety.....	60
11.2	Disposal	61
12	List of figures.....	62

General

Change history for operating instructions AHD-WAOP system

Date	Version	Reason for change	Page	Author
12/14/2011	AHD-WAOP_Dok_De_V1_20111214	Creation of operation manual	n.a.	Pasuki, Bahram (PaB)
05/15/2012	AHD-WAOP_Dok_En_V2_20120515	Added installation reference according to MSC/Cir.982 Complete revision and adjustment to new functions	30 Entire document	Pasuki, Bahram (PaB)
12/02/2013	AHD-WAOP_Dok_De_V3_20130212	Automatic operation AHD-WOP K added	24, 25, 35	Pasuki, Bahram (PaB)
04/12/2013	AHD-WAOP_Dok_De_V4_20130412	Renewal of preservative deleted	30	Patzke, Jens (PaJ)
		Earthing added	34, 35, 37	
		Minor changes	n.a.	
09/11/2014	AHD-WAOP_Dok_EN_V5_20140911	Pictures for AHD-WAOP K changed. Emergency Call function removed Additional devices added Complete rework in all sections	n.a.	Pasuki, Bahram (PaB)
06/10/2015	AHD-WAOP_Dok_EN_V6_20150610	Update of additional devices Update of example schems	21, 22, 32, 33, 41, 42	Pasuki, Bahram (PaB)
02/08/2017	AHD-WAOP_Dok_EN_V8_20170208	Times corrected Data for Terminals 1, corrected, connection diagram next to table	39	Patzke, Jens (PaJ)
06/22/2023	AHD-WAOP_Doc_EN_V9_20230622	Various corrections	n.a	Hof, André (HoA)
06/02/2026	AHD-WAOP_Doc_EN_V10_20260602	Additions / Revisions	n.a	Hof, André (HoA)

1 General

1.1 Information about the operating instructions

Read the operating instructions carefully before starting any work! They are part of the product and must be kept in the immediate vicinity of the product so that they are accessible to personnel at all times.

If the product is passed on to third parties, the operating instructions must also be provided.

These operating instructions provide important information on handling the AHD-WAOP product series, which includes the AHD-WAOP watch alarm panel, the AHD-WAOP K deadman alarm system, and associated components.

Compliance with all specified safety instructions and operating instructions for the product and all connected components is a prerequisite for safe operation.

In addition, the local accident prevention regulations and general safety regulations applicable to the area of application of the device must be observed.

The function and operation of the devices described here depend on the project-specific system configuration. Therefore, the project-specific documentation must always be consulted.

The illustrations in this manual are not always to scale in order to better illustrate the facts and may differ from the actual design of the product.

This operating manual is to be understood exclusively as a single unit. The use of excerpts from this operating manual as stand-alone documentation without reference to the entire document is not permitted.

1.2 Explanation of symbols

Warnings

Warnings are indicated by symbols in this operating manual. The warnings are preceded by signal words that express the extent of the danger.

It is essential to observe the warnings and act with caution in order to avoid accidents, personal injury, and damage to property!



DANGER!

... indicates an immediately dangerous situation that could result in death or serious injury if not avoided.

General



WARNING

... indicates a potentially hazardous situation that could result in death or serious injury if not avoided.



CAUTION!

... indicates a potentially hazardous situation that could result in minor or moderate injury if not avoided.



CAUTION!

... indicates a potentially hazardous situation which, if not avoided, could result in property damage.

Tips and recommendations



NOTE!

... highlights useful tips and recommendations as well as information for efficient and trouble-free operation.

1.3 Limitation of Liability

All information and instructions in this manual have been compiled in accordance with applicable standards and regulations, the state of the art, and our many years of knowledge and experience.

The manufacturer accepts no liability for damage resulting from:

- Failure to observe the manual
- Improper use
- Use by untrained personnel
- Unauthorized modifications
- Technical modifications
- Use of unauthorized spare parts

The actual scope of delivery may differ from the explanations and descriptions provided here in the case of special designs, the use of additional order options, or due to the latest technical changes.

In all other respects, the obligations agreed in the delivery contract, the general terms and conditions, the manufacturer's terms of delivery, and the legal regulations valid at the time of conclusion of the contract shall apply.

We reserve the right to make technical changes in the context of improving properties and further development.

1.4 Copyright protection

The operating instructions must be treated as confidential. They are intended exclusively for persons working with the product. The operating instructions may not be made available to third parties without the written consent of the manufacturer.



NOTE!

The content, texts, drawings, images, and other representations are protected by copyright and are subject to industrial property rights. Any misuse is punishable by law.

Reproduction in any form or manner, including excerpts, as well as the use and/or communication of the content, is not permitted without the written consent of the manufacturer. Violations will result in liability for damages. Further claims remain reserved.

1.5 Spare parts



WARNING!

Risk of injury due to incorrect spare parts!

Incorrect or defective spare parts can lead to damage, malfunctions, or total failure, and can compromise safety.

Therefore:

- Only use original spare parts from the manufacturer.

Spare parts must be obtained from authorized dealers or directly from the manufacturer (see page 2 for contact details).

1.6 Warranty terms

The warranty terms and conditions can be found in the sales documents and the manufacturer's general terms and conditions (GTC).

1.7 Customer Care

Our customer service department is available to provide technical information.

Information about the relevant contact person is available at any time by telephone, fax, e-mail, or via the Internet; see the manufacturer's address on page 2.

In addition, our employees are always interested in new information and experiences resulting from the application of our products that may be valuable for improving them.

Safety

2 Safety

This section provides an overview of all important safety aspects for optimum protection of personnel and for safe and trouble-free operation.

Failure to observe the instructions and safety information contained in this manual may result in considerable danger.

2.1 Responsibility of the operator

The product is used in a commercial environment. The operation of the product is therefore subject to the legal obligations for occupational safety.

In addition to the occupational safety instructions in this operating manual, the safety, accident prevention, and environmental protection regulations applicable to the area of application of the product must be observed. In particular, the following applies:

- The operator must inform themselves about the applicable occupational safety regulations and, in addition, identify any hazards arising from the specific working conditions at the product's place of use in a risk assessment. They must implement this in the form of operating instructions for the operation of the product.
- Throughout the entire period of use of the product, the operator must check whether the operating instructions they have created comply with the current regulations and adapt them if necessary.
- The operator must clearly regulate and define the responsibilities for installation, operation, maintenance, and cleaning.
- The operator must ensure that all employees who handle the product have read and understood the operating instructions. In addition, they must train staff at regular intervals and inform them of any hazards.

Furthermore, the operator is responsible for ensuring that the product is always in technically perfect condition.

2.2 Personnel requirements

2.2.1 Qualifications



WARNING!

Risk of injury if qualifications are insufficient!

Improper handling can result in serious personal injury and property damage.

Therefore:

- All work must be carried out by qualified personnel only.

The operating instructions specify the following qualifications for various areas of activity.

■ **Trained person**

has been trained by the operator and instructed in the tasks assigned and is aware of the potential hazards associated with improper execution.

■ **Specialist**

is able to perform the assigned tasks and independently recognize and avoid potential hazards due to their professional training, knowledge, and experience, as well as their knowledge of the relevant standards and regulations.

■ **Electrical specialist**

is qualified to perform work on electrical systems and independently identify and avoid potential hazards based on their professional training, knowledge, experience, and familiarity with relevant standards and regulations.

The qualified electrician is trained for the specific location in which they work and is familiar with the relevant standards and regulations.

Only persons who can be expected to perform their work reliably are permitted to work as personnel. Persons whose responsiveness is impaired, e.g., by drugs, alcohol, or medication, are not permitted to work.

- When selecting personnel, the age and occupation-specific regulations applicable at the place of work must be observed.

Safety

2.2.2 Unauthorized persons



WARNING! Danger to unauthorized persons!

Unauthorized persons who do not meet the requirements described here are not aware of the hazards in the work area.

Therefore:

- Keep unauthorized persons away from the work area.
- If in doubt, approach individuals and ask them to leave the work area.
- Interrupt work as long as unauthorized persons are in the work area.

2.3 Intended use

The AHD-WAOP system with its main components WAOP and AHD-WAOP K are designed and constructed exclusively for the purpose described here.

The AHD-WAOP watch alarm panel monitors the watch readiness of the bridge crew.

The AHD-WAOP K watch alarm panel is used to monitor the watch readiness of a watchman, for example, to be able to locate them quickly in the event of an accident.

The accessories mentioned, such as buttons, signal transmitters, and motion detectors, are used to acknowledge watch readiness or a watch duty.

Application

- For ships ≥ 150 GT and passenger ships, regardless of their size, built on or after July 1, 2011
- For passenger ships, regardless of size, built before July 1, 2011, but no later than the first class survey after July 1, 2011
- For ships ≥ 3000 GT, built before July 1, 2011, but no later than the first class survey after July 1, 2012
- For ships ≥ 500 GT, but less than 3000 GT, built before July 1, 2011, at the latest after the first class survey after July 1, 2013
- For ships ≥ 150 GT, but less than 500 GT, built before July 1, 2011, at the latest after the first class survey after July 1, 2014



WARNING!

Danger due to improper use!

Any use of the product that goes beyond its intended use and/or is different from its intended use can lead to dangerous situations.

Therefore:

- Only use the product as intended.
- Strictly adhere to all information in this operating manual.
- In particular, refrain from the following uses of the product, which are considered improper:
 - Use of a supply voltage other than that specified

Claims of any kind for damage resulting from improper use are excluded.

The operator is solely liable for all damage resulting from improper use.



WARNING!

Danger due to improper operation of the product!

Failure or malfunction of the product can lead to personal injury or property damage in the overall system.

Therefore:

- Even if the product itself does not pose any particular hazards, the effects of failure or malfunction on the overall system must be considered.
- Always discontinue use if the products emit smoke or abnormal heat.

Design and function

3 Design and function

The AHD-WAOP system components developed by Böning are used to set up a Bridge Navigation Watch Alarm System (BNWAS) in accordance with the requirements of IEC 62616-1.

The following components are available for setting up a Bridge Navigation Watch Alarm System (BNWAS) and can be combined as needed:

Description	Item no.	Function
AHD-WAOP	13146	Watch alarm operation panel (BNWAS), central operating unit for the bridge
AHD-WAOP K	13224	Watchkeeper alarm panel (dead man system) with key switch
AHD-WAOP MD AHD-WAOP MDA	13224	Set with motion detector and adapter module
AHD-WAOP SA	16110	display module (flush mounting)
AHD-WAOP SA AP	15052	display module (on-wall mounting)
AHD-WAOP SK	16111	reset module with emergency call (flush mounting)
AHD-WAOP SK AP	14716	reset module with emergency call (on-wall mounting)
AHD-WAOP SB	14712	display module with emergency call (with mushroom button for bridge)

3.1 General function

With the central components AHD-WAOP and AHD-WAOP K for monitoring standby duty and guard patrols, Böning offers compact and effective devices for use as watch alarm panels or deadman alarm systems:

- **AHD-WAOP**
The AHD-WAOP watch alarm panel serves as the central control unit for the bridge and ensures that the bridge crew is constantly on watch. If the alarm is not acknowledged within the specified watch period, a multi-stage alarm is triggered. This begins with a pre-alarm and escalates to a general alarm if the alarm is still not acknowledged.
- **AHD-WAOP K**
The watch alarm panel (dead man system) is designed as an emergency alarm for use in engine rooms. The device secures the watchkeeper on board the ship and helps to ensure that the person can be found quickly in the event of an accident.

AHD-WAOP and AHD-WAOP K can be easily integrated into a Böning ship alarm system or AMCS.

With the help of the integrated display and the control buttons, the prescribed reporting times can be set directly on the panels (see items 8.7 and 8.8).

To prevent unauthorized changes to parameters, the settings menu is additionally protected with a password. The stored values are protected against power failure, so that the last stored operating status is automatically restored after the power is turned back on.

3.2 AHD-WAOP (watch alarm panel)

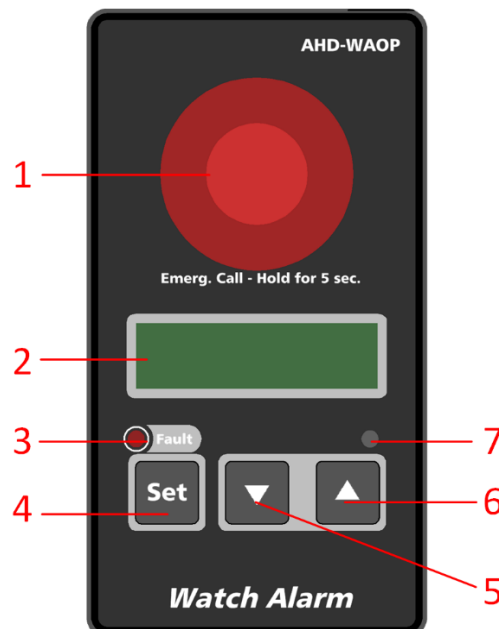

Figure 1: AHD-WAOP Front view

The individual elements of the AHD-WAOP:

- (1) Mushroom button
- (2) Display
- (3) Fault LED
- (4) Set button for system settings
- (5) Down arrow key
- (6) Up arrow button
- (7) Photo LED for automatic adjustment of panel lighting

Design and function

In standard operating mode (Mode="ON"), monitoring starts approx. 20 seconds after the supply voltage is applied. The integrated time counter then starts with the configured elapsed time (3..12 min) and counts down.

After the end of the elapsed time (counters reach zero), the device switches to warning level 1 (Step 1) and the integrated mushroom button starts flashing. The same applies to external signals and buttons connected to the device via terminal strip ST1.

To avoid an acoustic signal, acknowledgment should be given at this point at the latest by pressing one of the flashing buttons (internal or external). This resets the counter to the specified elapsed time.

Manual emergency call

In an emergency, a general emergency call can be triggered manually at any time. To do this, press and hold the mushroom button on the AHD-WAOP or via an externally connected device (via ST1) for at least 5 seconds.

The device immediately activates warning levels 1 to 3 (including alarm output). The general alarm (warning level 4) is only triggered after a further 90 seconds, unless acknowledged beforehand.

The manual alarm can be acknowledged and terminated at any time by briefly pressing the acknowledgment button (internal mushroom button or external).

Extensions

To extend the functionality, four external signal and acknowledgment devices (buttons, approved ECDIS system, or motion detector) can be connected directly to the panel (for connection, see also item 4.7). Furthermore, an external start-stop function can be activated, which can be used to remotely activate or deactivate the monitoring function (see item 0).

Acknowledgment devices for signaling and acknowledgment can be installed at any positions on the bridge or in the engine room. If more than 4 devices are required, the number can be easily increased by connecting them in parallel.

3.2.1 AHD-WAOP warning levels

After the specified acknowledgment time has elapsed, the device switches to warning level 1. If there is still no acknowledgment, the system escalates to warning levels 2, 3, and 4 at regular intervals.

The following diagram shows the sequence of warning levels:

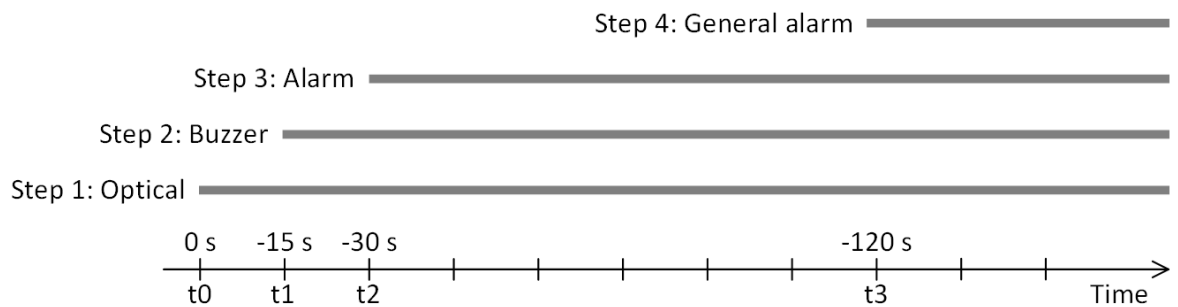

Figure 2: AHD-WAOP warning levels

- t_0 (end of the timeout period)
Warning level 1 active: Mushroom head button starts flashing.
=> **Note**
- t_1 (15 seconds after end of timeout)
Warning level 2 active: Internal buzzer is activated, alarm output ST6 (terminal 1-2) switches
=> **Advance warning**
- t_2 (30 seconds after the end of the timeout period)
Warning level 3 active: bridge alarm is activated, Alarm output ST6 (terminal 3-5) switches
=> **Alarm sounds in the bridge area**
- t_3 (120 seconds after the end of the elapsed time)
Warning level 4 active: General alarm is activated, alarm output ST6 (terminals 6-8) switches
=> **alarm sounds throughout the entire ship**

Use levels 3 and 4 in combination

Due to specific regulations, it may be necessary to trigger warning levels 3 and 4 simultaneously. In this case, the alarm output of warning level 3 is used to activate the bridge alarm and general alarm in parallel. As a rule, the elapsed time for the 3rd warning level is increased here. If the setting range is not sufficient, a special version with a longer elapsed time (max. 180 seconds) can be created on request.



NOTE!

With the AHD-WAOP, the elapsed time until the first warning level is reached can be set within a range of 3 to 12 minutes (see item 8.7).

Design and function

3.2.2 External start-stop function - AHD-WAOP

AHD-WAOP has a special function that is activated in "AUTO" mode (see setting menu item 8.7). This allows remote activation or deactivation of the standby function via external signals.

This requires a signal transmitter that issues the corresponding start and stop commands. The standby function is controlled as follows:

- ON: VCC input (terminal 6) = +24 V DC
 Start input (terminal 4) = GND (negative signal)
- OFF: VCC input (terminal 6) = +24 V DC
 Stop input (terminal 5) = GND (negative signal)

Please note the following regarding function:

1. When activated by an external signal, for example by the autopilot, the start input of the AHD-WAOP and the time counter begins to count down. Once zero is reached, acknowledgment must be given and the time counter starts again. This procedure is repeated until the external signal generator sends a stop signal.
2. As soon as the external signal generator (e.g., autopilot) is deactivated, the monitoring function of the AHD-WAOP can be terminated by a stop signal input. The countdown that is still running is interrupted or stopped.



CAUTION!

The use of GPS systems or speed log systems as signal transmitters is not permitted!

External signal transmitters include, for example:

- Autopilots
- Course control systems
- Track control systems

3.3 AHD-WAOP K (deadman alarm system)

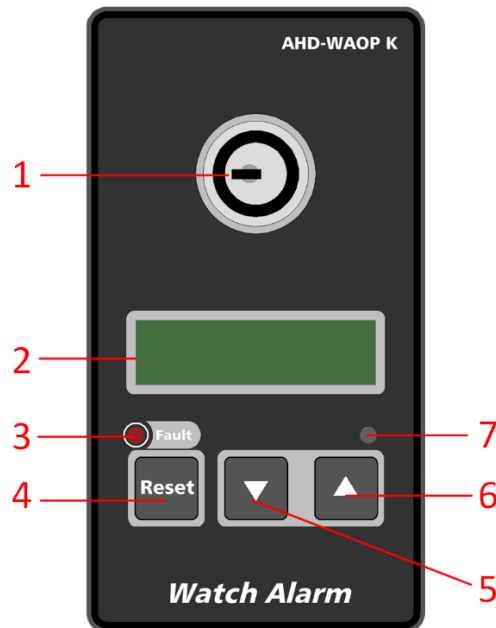

Figure 3: AHD-WAOP K front view

The individual elements of the AHD-WAOP-K:

- (1) Key switch
- (2) Display
- (3) Fault LED
- (4) QUIT button
- (5) Down arrow key
- (6) Up arrow key
- (7) Photo LED for automatic adjustment of panel lighting

The AHD-WAOP K deadman alarm panel is equipped with a key switch and has a separate quit button.

At the start of the watchman, the key is turned clockwise and removed to arm the alarm and start the alarm time. The elapsed time must always be selected so that the guard duty can be safely completed before the first warning level is reached.

After completing the guard duty, the key is reinserted into the device and turned counterclockwise to its starting position. This deactivates the alarm.

Extensions

To extend the functionality, four external signal and acknowledgment devices (buttons, approved ECDIS system, or motion detectors) can be connected directly to the panel (for connection, see also item 4.7).

Design and function

Furthermore, an external start function can be activated, which allows the monitoring function to be activated remotely (see item 3.3.2).

Acknowledgment devices for signaling and acknowledgment can be installed at any positions on the bridge or in the engine room. If more than 4 devices are required, the number can be easily increased by connecting them in parallel.

3.3.1 AHD-WAOP K Warning levels

After activating monitoring at the start of a watch, the time counter starts with the specified elapsed time (max. 30 min).

180 seconds before reaching zero, the device activates warning levels 1 and 2. The integrated mushroom head button starts flashing and the internal buzzer sounds. The same applies to external signals and buttons connected to the device via the ST1 terminal strip.

To avoid an alarm, acknowledgment should be made within the remaining 180 seconds at the latest by pressing the integrated quit button once. The counter is then reset to the specified start time. Alternatively, AHD-WAOP K can be deactivated at any time by reinserting the key.

If acknowledgment still does not occur, the system escalates to warning levels 3 and 4 at regular intervals. The following diagram shows the sequence of warning levels:

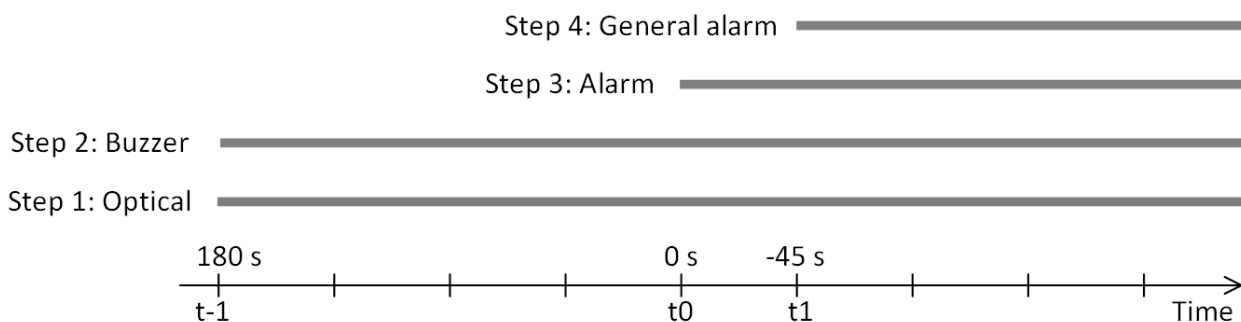

Figure 4: AHD-WAOP K warning levels

- $t-1$ (180 seconds before the end of the timeout period)
Warning level 1 active: mushroom button starts flashing,
Warning level 2 active: Internal buzzer is activated,
Alarm output ST6 (terminal 1-2) switches
=> **Note + advance warning**

- t0 (end of timeout)
Warning level 3 active: Bridge alarm is activated,
alarm output ST6 (terminals 3-5) switches
=> **alarm is triggered in the bridge area**
- t1 (45 seconds after end of timeout)
Warning level 4 active: General alarm is activated,
Alarm output ST6 (terminal 6-8) switches
=> **alarm sounds throughout the entire ship**

Use levels 3 and 4 in combination

Due to specific regulations, it may be necessary to trigger warning levels 3 and 4 simultaneously. In this case, the alarm output of warning level 3 is used to activate the bridge alarm and general alarm in parallel.



NOTE!

With AHD-WAOP K, the delay time until the start of the 3rd warning level can be set to a maximum of 30 minutes (see item 8.8).

3.3.2 External start function - AHD-WAOP K

AHD-WAOP K has a special function that enables remote activation of the standby function via an external start signal. For this purpose, the collective alarm information from the ship or engine alarm system is usually evaluated. The monitoring function is started as follows:

- ON: VCC input (terminal 6) = +24 V DC
 Start input (terminal 4) = GND (negative signal)

Please note the following for this function:

1. If the AHD-WAOP K is not acknowledged in the engine room within the preset time limit (countdown max. 30 min), an alarm is triggered on the bridge or in the officers' cabins.
2. The monitoring function is started automatically or manually:
 - when an engine alarm has been triggered (automatic control)
 - the officer in charge enters the engine room for an inspection (manual control)

Design and function

3. When leaving the engine room, the officer in charge can manually switch off the monitoring of the AHD-WAOP K, provided that the device has not been activated automatically beforehand. In this case, the AHD-WAOP K can only be switched off if all active alarms have been acknowledged (acoustically and visually).
4. The AHD-WAOP K, which triggers the "personal alarm" in the event of an alarm, may also trigger the "engineer alarm" (part of the watchkeeping alarm system).



NOTE!

The stop input on the AHD-WAOP K (terminal 5) has no function in this application.

3.4 emergency power supply

In the event of a failure of the main power supply for the AHD-WAOP or AHD-WAOP K system, device operation must be ensured via emergency power for at least another six hours. Since the panels only have a single power supply, the shipyard must provide for automatic switching to emergency power, for example by means of relay control.

3.5 Additional alarm and acknowledgment panels

Additional alarm and acknowledgment panels are available as accessories. These can be integrated into the standby system as required and perform specific functions.

All alarm and acknowledgment panels can be combined with both AHD-WAOP and AHD-WAOP K.

3.6 Connection of a voyage data recorder

AHD-WAOP or AHD-WAOP K have an integrated RS 485 interface. This can be used to output an NMEA 0183 protocol, which enables the control of a voyage data recorder (VDR).

3.6.1 Protocol

AHD-WAOP - NMEA 0183 Data Protocol

1. Interface – RS-485. Terminals ST6.12 – A / ST6.13 – B
2. Data transfer protocol – NMEA 0183
3. Interface settings – 9600 Bit/s, 8 Bit, 1 Stop Bit
4. IMO resolution A.861(20), paragraph 5.4.9
5. Data frame description:

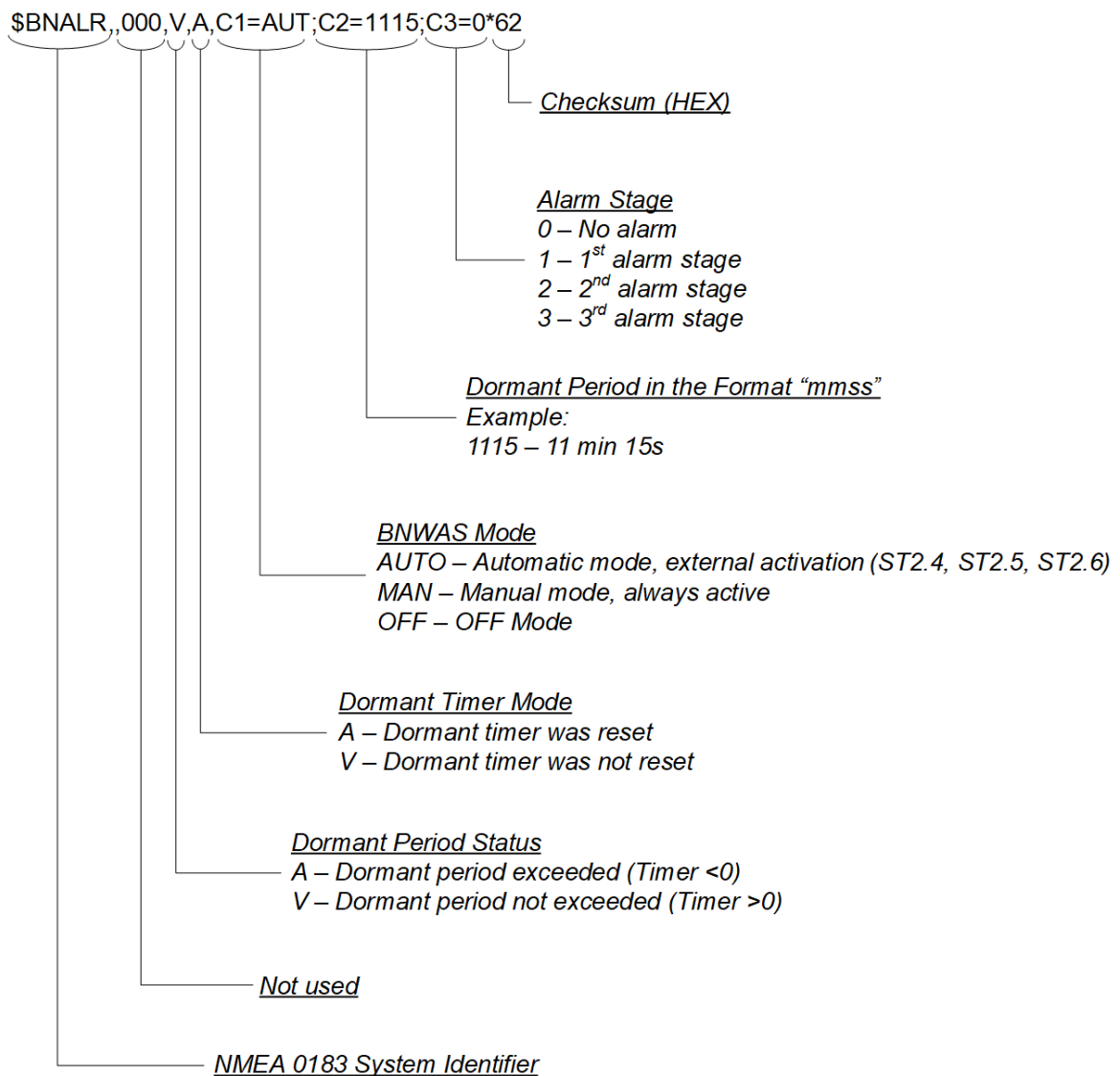

Design and function

3.8 AHD-WAOP SB

The AHD-WAOP SB is an alarm and display device for installation in consoles or control panels in the bridge area. The device indicates an active alarm in the watchkeeping system visually and acoustically.

In case of danger, a direct emergency call can be triggered by pressing the mushroom button for at least 5 seconds to summon rapid assistance.

The AHD-WAOP S can be combined with both the AHD-WAOP and the AHD-WAOP K. The device is equipped with automatic dimming for glare-free use in the bridge area. For installation, see application examples under item 5.

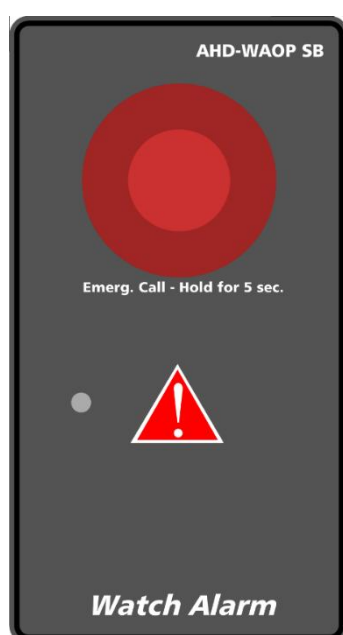

Figure 5: AHD-WAOP SB front view

3.9 AHD-WAOP SA

AHD-WAOP SA serves as an additional panel for local display of alarm states in the standby system. Alarm acknowledgment is not possible with this panel. The device is available in two versions:

- AHD-WAOP SA: Built-in device for installation in consoles, consoles, or walls with the appropriate wall depth.
- AHD-WAOP SA AP: Surface-mounted device with IP protection class IP 65 for outdoor use.

For installation, see application examples under item 5.



Figure 6: AHD-WAOP SA built-in device

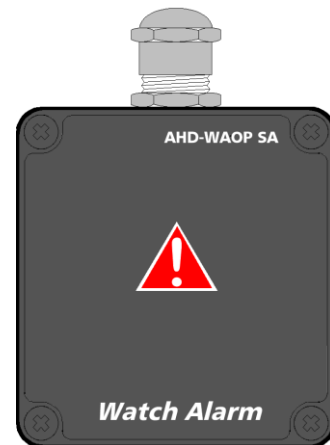

Figure 7: AHD-WAOP SA AP surface-mounted device

3.10 AHD-WAOP SK

AHD-WAOP SK serves as a reset panel for switching off or resetting standby alarms. It is designed for installation in the machine room in order to reset an active alarm from the standby system.

By pressing the RESET button for at least 5 seconds, a direct emergency call alarm can be triggered in case of danger. The device is available in two versions:

- AHD-WAOP SK: Built-in device for installation in consoles, consoles, or walls with the appropriate wall depth.
- AHD-WAOP SK AP: Surface-mounted device with IP protection class IP 65 for outdoor use.

For installation, see application examples under item 5.



Figure 8: AHD-WAOP SK built-in device



Figure 9: AHD-WAOP SK AP surface-mounted device

Design and function

3.11 AHD-WAOP MD / AHD-WAOP MDA

AHD-WAOP MD is a motion detector and offers an additional option for automatic acknowledgment of guard duty alarms.

For example, security guards can be monitored as they walk a specified route, or bridge crews can be monitored for expected movements. If no movement is detected within a set period of time, an alarm is triggered. AHD-WAOP MD is supplied as a set with a matching connection adapter AHD-WAOP MDA, which connects directly to AHD-WAOP or AHD-WAOP K.

The motion detector has a "dual detection" mode and works with both infrared and ultrasound. This increases the area covered and at the same time prevents false alarms. In addition, the motion detector is equipped with a tamper contact that prevents tampering with the device. The motion detector is connected via the AHD-WAOP MDA adapter.

The adapter is designed for installation on standard top-hat rails in control cabinets and can therefore be placed independently of the motion detector's installation location. For installation, see application examples under item 5.

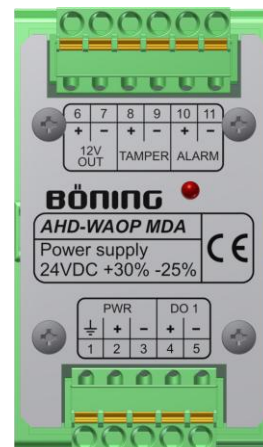

Figure 10: AHD-WAOP MD motion detector (similar to illustration) with AHD-WAOP MDA adapter

4 Technical information

4.1 Technical data AHD-WAOP

Power supply	24 V DC (+30% / -25%)
Current consumption	Max. 250 mA
Ambient temperature	-15°C to 70°C
Storage temperature	-50°C ... 85°C
Weight	Approx. 0.4 kg
Protection	IP65 (front) IP20 (rear)
External dimensions	130 mm x 70 mm x 80 mm (plus 27 mm installation height Mushroom button)
Desk cutout	107 mm x 59 mm
Interface	RS-485 (data output to VDR)
Input	4 inputs for external signal transmitters External start input External stop input
Output	External buzzer (250 V AC/0.5 A) Alarm (250 V AC/0.5 A) General alarm (250 V AC/0.5 A) Error output (250 V AC/0.5 A)
Required distance from compass	Magnetic control compass: 0.50 m Magnetic steering compass: 0.40 m
Approvals	ABS, DNV, LR, RINA
Article number	13146

4.1.1 Device dimensions AHD-WAOP

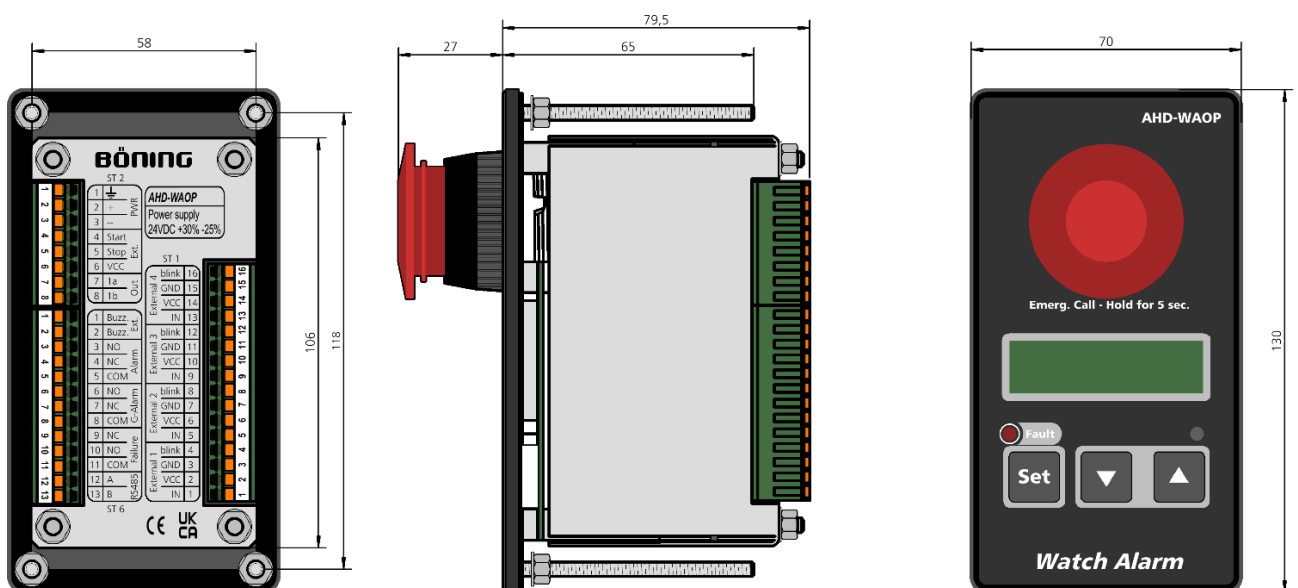

Figure 11: AHD-WAOP dimensions

Technical information

4.2 Technical data AHD-WAOP K

Power supply	24 V DC (+30% / -25%)
Current consumption	Max. 250 mA
Ambient temperature	-15°C to 70°C
Storage temperature	-50°C to 85°C
Weight	Approx. 0.4 kg
Protection	IP65 (front) IP20 (rear)
External dimensions	130 mm x 70 mm x 80 mm
Countertop cutout	107 mm x 59 mm
Interface	RS-485 (data output to VDR)
Input	4 inputs for external signal transmitters External start input External stop input
Output	External buzzer (250 V AC/0.5 A) Alarm (250 V AC/0.5 A) General alarm (250 V AC/0.5 A) Error output (250 V AC/0.5 A)
Required distance from compass	Magnetic control compass: 0.50 m Magnetic steering compass: 0.40 m
Approvals	ABS, DNV, LR, RINA
Article number	13224

4.2.1 Device dimensions AHD-WAOP K

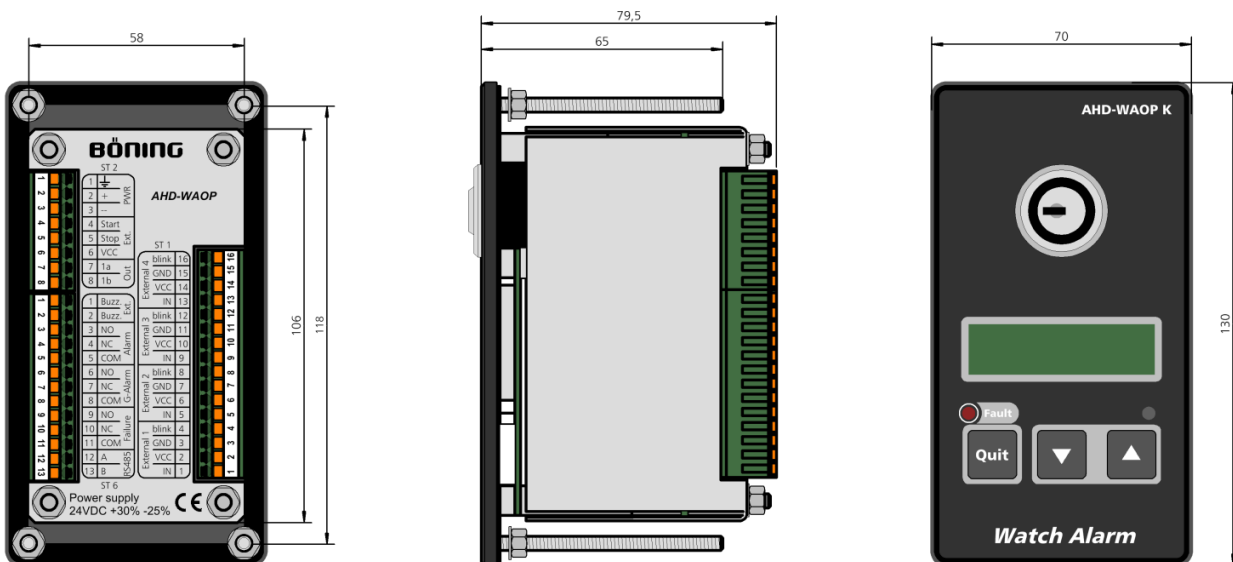

Figure 12: Dimensions AHD-WAOP K

4.3 Technical data AHD-WAOP SB

Power supply	24 V DC (+30% / -25%)
Current consumption	Max. 250 mA
Ambient temperature	-15°C to 70°C
Storage temperature	-50°C ... 85°C
Weight	Approx. 0.4 kg
Protection	IP65 (front) IP20 (rear)
External dimensions	130 mm x 70 mm x 65 mm (plus 27 mm installation height Mushroom button)
Countertop cutout	107 mm x 59 mm
Output	1x ext. buzzer (250 V AC/0.5 A) 1x ext. opt. alarm signal (250 V AC/0.5 A) 1x NO relay (250 V AC/0.5 A)
Approvals	ABS, DNV, LR, RINA
Article number	14712

4.3.1 Device dimensions AHD-WAOP SB

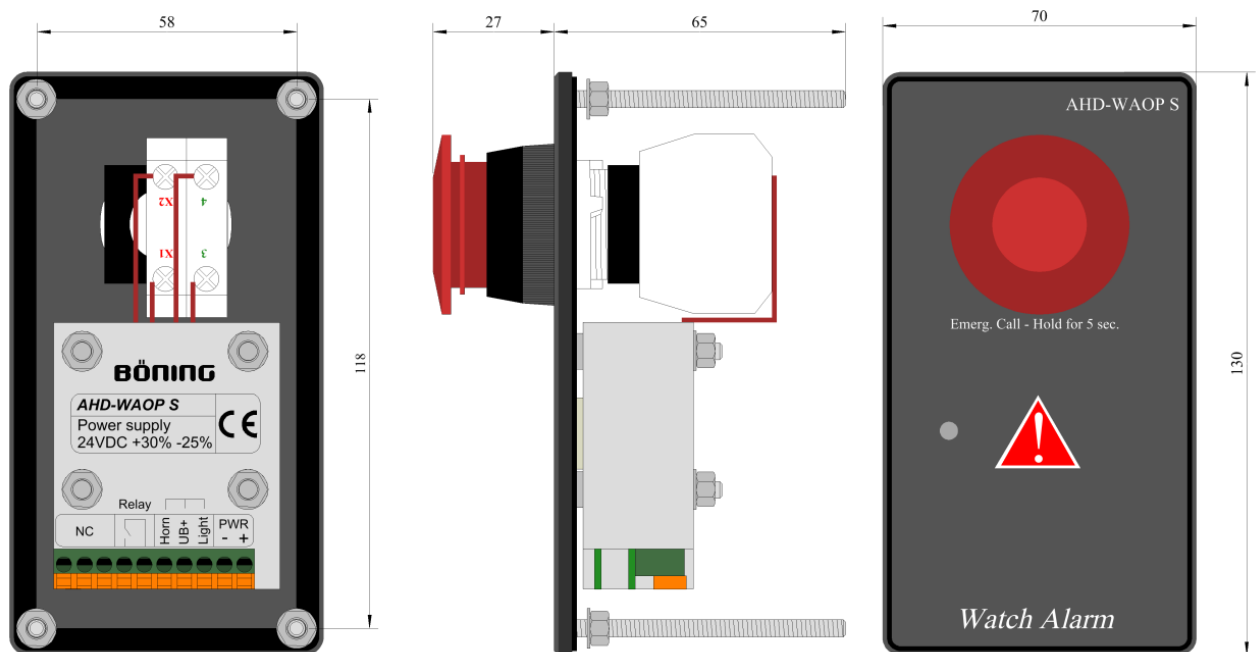

Figure 13: Dimensions AHD-WAOP SB

Technical information

4.4 Technical data AHD-WAOP SA

Power supply	24 V DC (+30% / -25%)
Current consumption	Max. 250 mA
Ambient temperature	-15°C to 70°C
Storage temperature	-50°C to 85°C
Weight	Approx. 0.4 kg
Protection	IP65 (front) IP20 (rear)
Dimensions	
Built-in version AHD-WAOP SA	75 mm x 80 mm x 41 mm (Dashboard cutout = 48 mm x 63 mm)
Surface-mounted version AHD-WAOP SA AP	75 mm x 80 mm x 45 mm
Output	2x ext. buzzer (250 V AC/0.5 A) 1x ext. opt. alarm signal (250 V A C/ 0.5 A)
Approvals	ABS, DNV, LR, RINA
Article numbers	
Built-in version AHD-WAOP SA	16110
Surface-mounted version AHD-WAOP SA AP	15052

4.4.1 Device dimensions AHD-WAOP SA

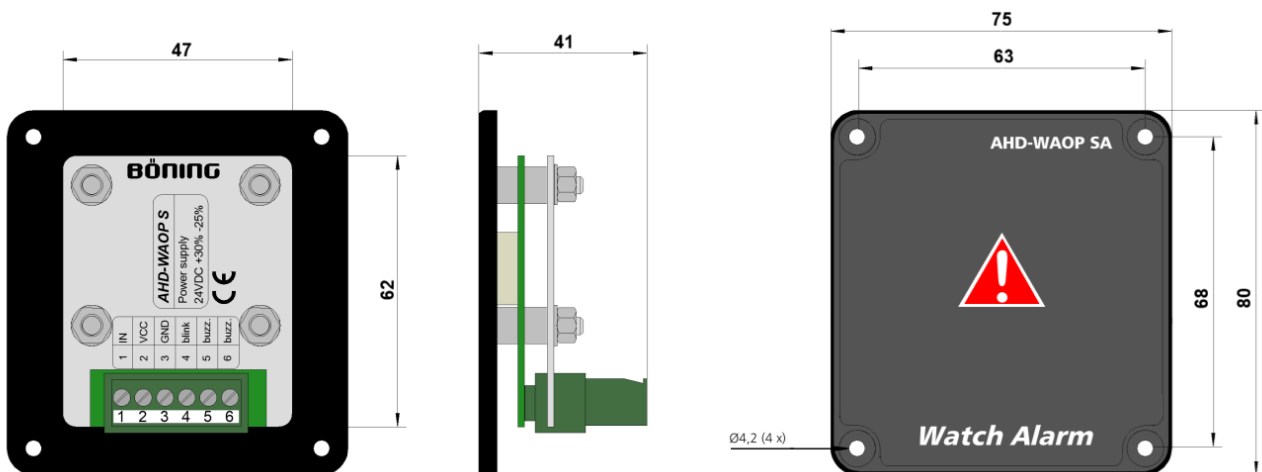

Figure 14: Dimensions AHD-WAOP SA (built-in version)

4.4.2 Device dimensions AHD-WAOP SA AP

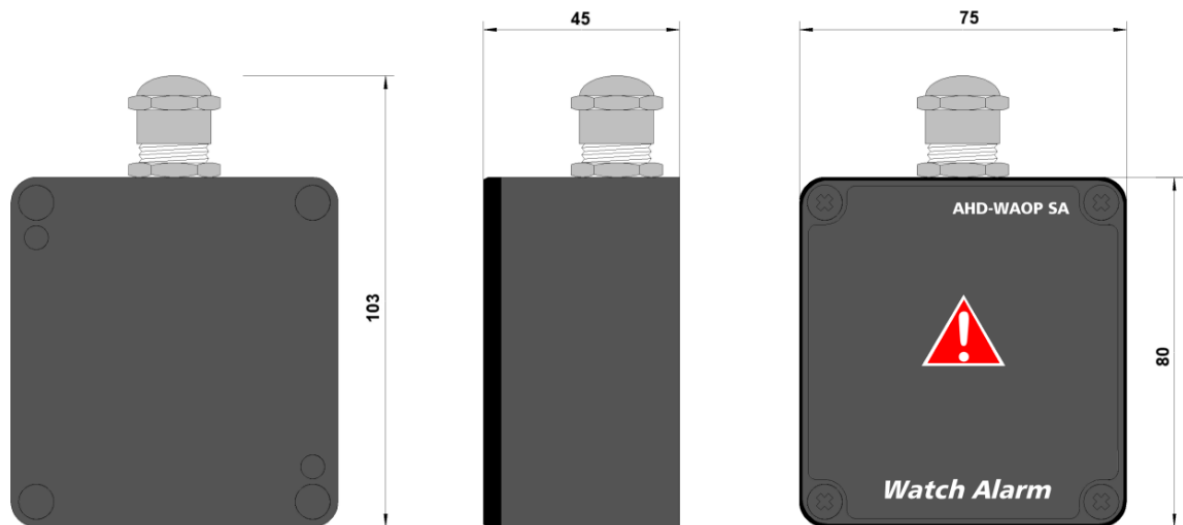

Figure 15: Dimensions AHD-WAOP SA AP (surface-mounted version)

4.5 Technical data AHD-WAOP SK

Power supply	24 V DC (+30% / -25%)
Current consumption	Max. 250 mA
Ambient temperature	-15°C ... 70°C
Storage temperature	-50°C ... 85°C
Weight	Approx. 0.4 kg
Protection	IP65 (front) IP20 (rear)
Dimensions	
Built-in version AHD-WAOP SA	75 mm x 80 mm x 41 mm (Dashboard cutout = 48 mm x 63 mm)
Surface-mounted version AHD-WAOP SA AP	75 mm x 80 mm x 45 mm
Output	2x ext. buzzer (250 V AC/0.5 A) 1x ext. opt. alarm signal (250 V AC / 0.5 A)
Approvals	ABS, DNV, LR, RINA
Article numbers	
Installation version AHD-WAOP SK	16111
Surface-mounted version AHD-WAOP SK AP	14716

Technical information

4.5.1 Device dimensions AHD-WAOP SK

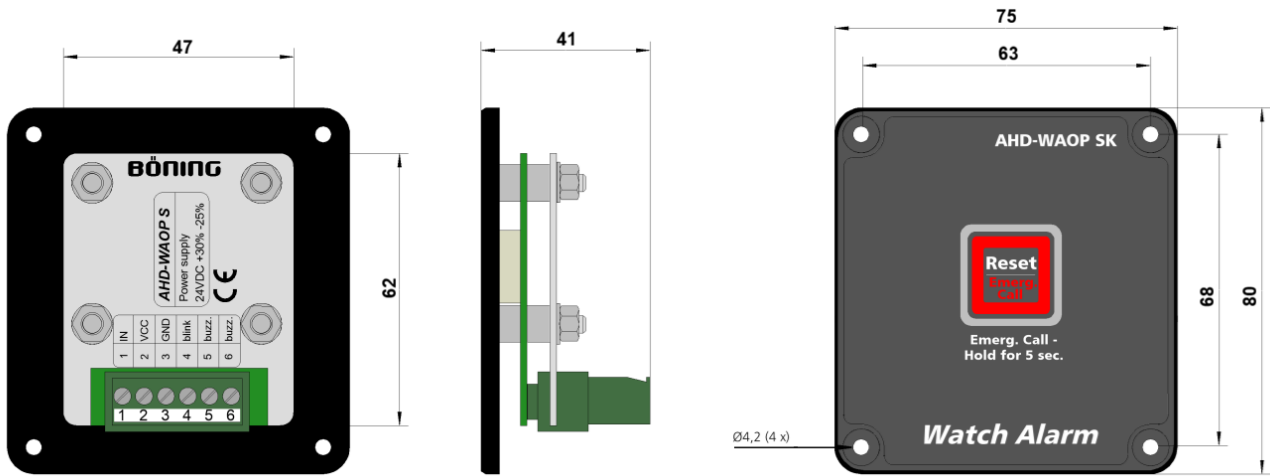

Figure 16: Dimensions AHD-WAOP SK (built-in version)

4.5.2 Device dimensions AHD-WAOP SK AP

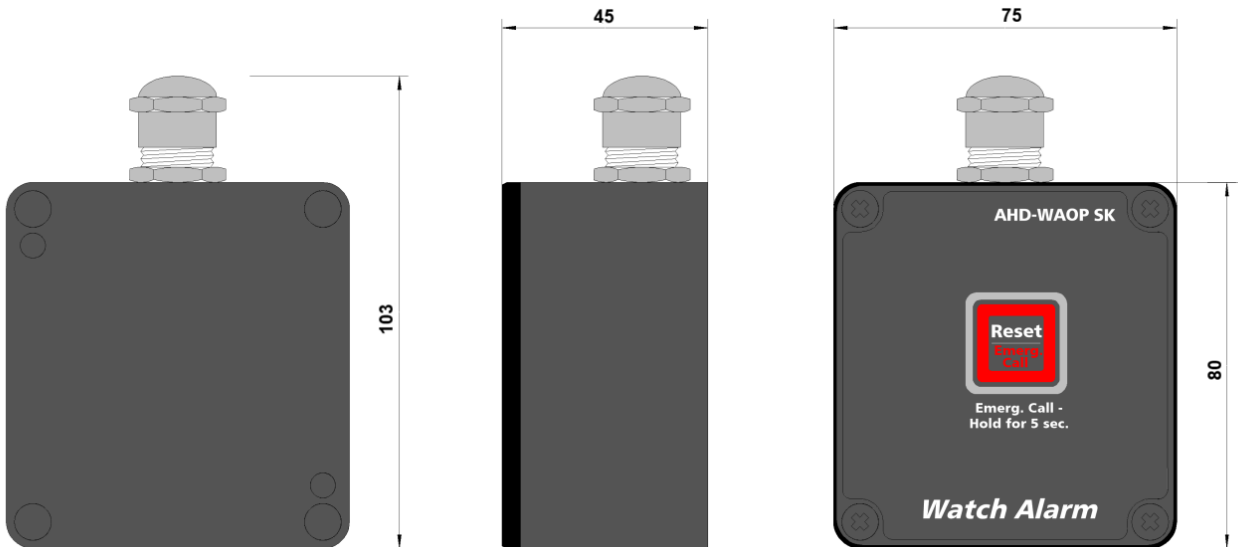

Figure 17: Dimensions AHD-WAOP SK AP (surface-mounted version)

4.6 Technical data AHD-WAOP MD / AHD-WAOP MDA

AHD-WAOP MDA

Power supply	24 V DC (+30% / -25%)
Current consumption	approx. 26 mA
Ambient	5°C...~ +40°C
Monitoring field	14 m / 90°
Weight	Approx. 65 g
Protection class	IP 20
External dimensions	60 mm x 110 mm x 46 mm
Installation	Wall bracket, screw mounting
Output	2 x NC contact, 40V 0.1A (alarm and tamper)

AHD-WAOP MDA

Power supply	24 V DC (+30% / -25%)
Current consumption	max. 250mA
Ambient	-15°C...~ +70°C
Storage temperature	-50°C...~ +85°C
Protection class	IP 20
Weight	Approx. 200 g
External dimensions	45 mm x 53.4 mm x 77 mm
Installation	Mounting rail TS32 / TS35
Output	For AHD-WAOP MD: 1 x 12VDC out 2 x input (alarm and tamper) To AHD-WAOP system: Digital output (optocoupler)
Article number	10378 (Set consisting of AHD-WAOP MD and AHD-WAOP MDA)

Technical information

4.6.1 Device dimensions AHD-WAOP MD / AHD-WAOP MDA



Figure 18: Dimensions of AHD-WAOP MD (illustration may vary)

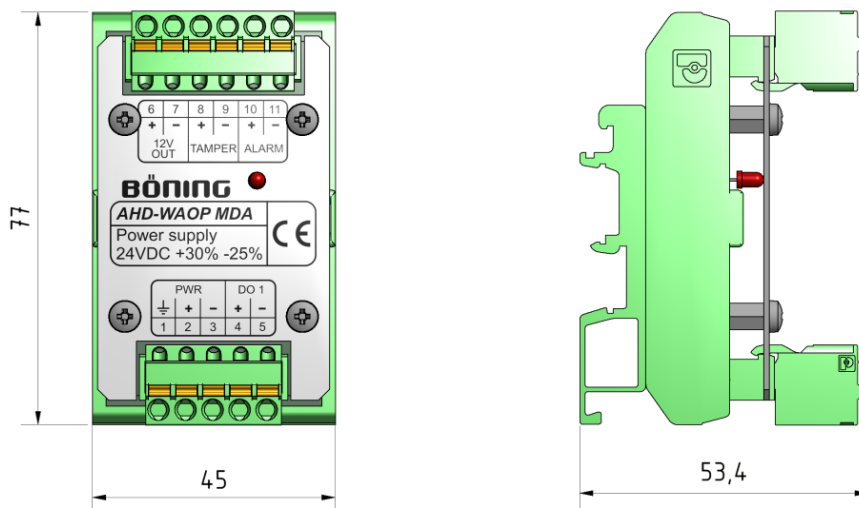

Figure 19: Dimensions of AHD-WAOP MDA (adapter)

4.7 Connection terminals AHD-WAOP / AHD-WAOP K

AHD-WAOP and AHD-WAOP K have several potential-free relay outputs that can be used to directly control the external alarm devices "Buzzer" (pre-alarm), "Alarm," and "General Alarm." An internal device error is signaled via the "Failure" output.

The RS485 interface (terminal 12/13) is used to control a Voyage Data Recorder (VDR); all active alarm states are sent via an NMEA 0183 protocol.

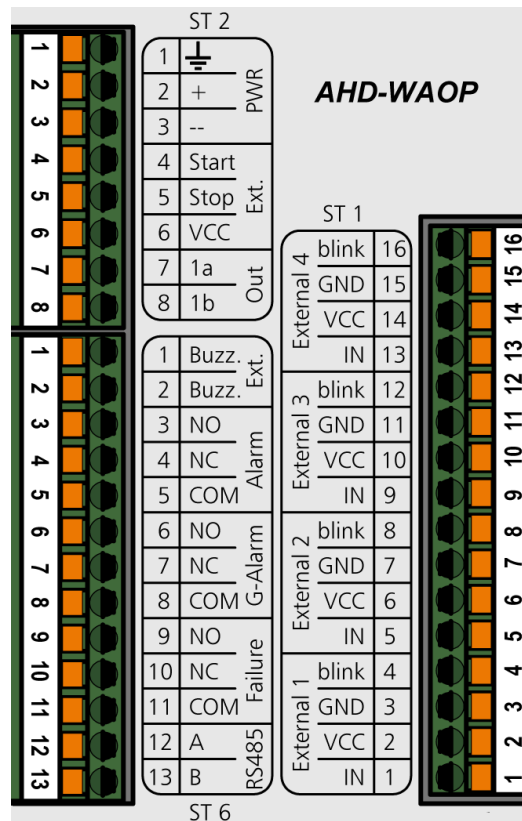
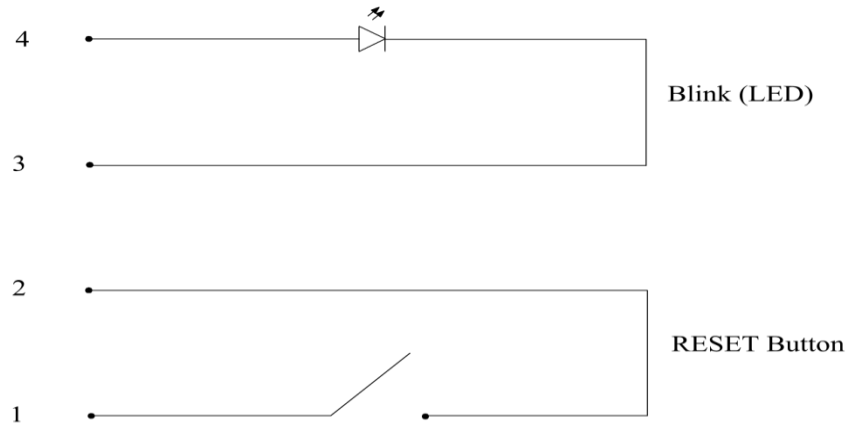



Figure 20: Connection terminals AHD-WAOP / AHD-WAOP K

Connector strip ST1			
Terminal	Designation		Description
	1	2	
1/5/9/13	IN	External 1/2/3/4	Input RESET
2/6/10/14	VCC		Output RESET
3/7/11/15	GND		GND for LED (flashing light)
4/8/12/16	flashing		Output for LED (flashing light)

Technical information

Schematic diagram External 1-4 (ST1)



Connector strip ST2			
Terminal	Designation		Description
	1	2	
1		PWR	Grounding (GND)
2	+		Power supply positive
3	--		Power supply minus
4	Start	Ext.	See schematic diagram and 4.7.2.1
5	Stop		See schematic diagram and 4.7.2.1
6	VCC		See schematic diagram and 4.7.2.1
7	1a	Out	Not used (option)
8	1b		

Schematic diagram Ext. (ST2)

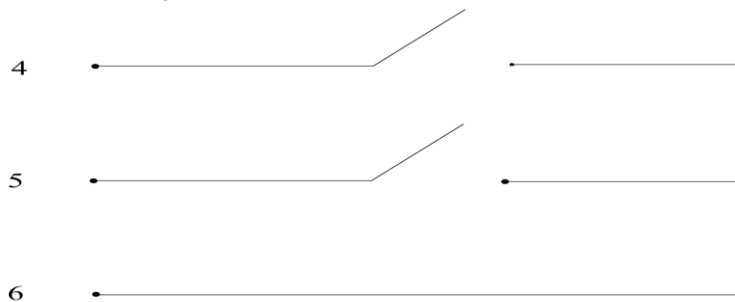

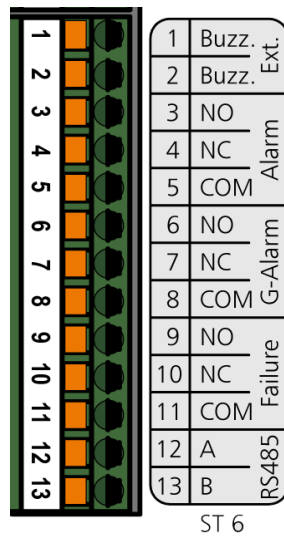
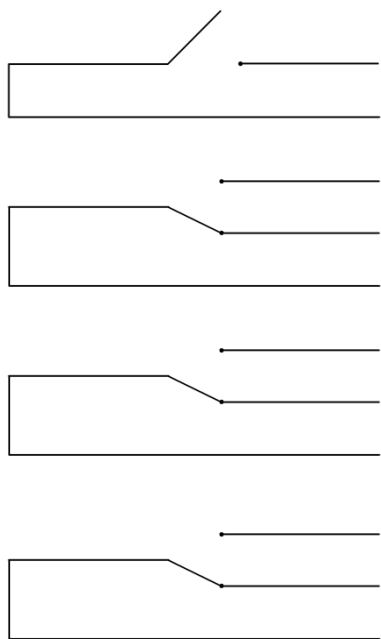

Figure 21: Connection terminal ST6 (AHD-WAOP / AHD-WAOP K)



Connector strip ST6			
Terminal	Designation		Description
	1	2	
1	NO.	Ext. Buzzer	External buzzer connection (NO)
2	COM		Connection for external buzzer (COM)
3	NO	Alarm	Alarm connection (NO)
4	NC		Alarm connection (NC)
5	COM		Alarm connection (COM)
6	NO	G alarm	G alarm connection (NO)
7	NC		G-alarm connection (NC)
8	COM		G-alarm connection (COM)
9	NO	Failure	Connection Failure (NO)
10	NC		Connection failure (NC)
11	COM		Connection Failure (COM)
12	A	RS485	Connection Data Voyage Recorder
13	B		Connection Data Voyage Recorder

Technical information

4.8 Connection terminals AHD-WAOP MD / AHD-WAOP MDA

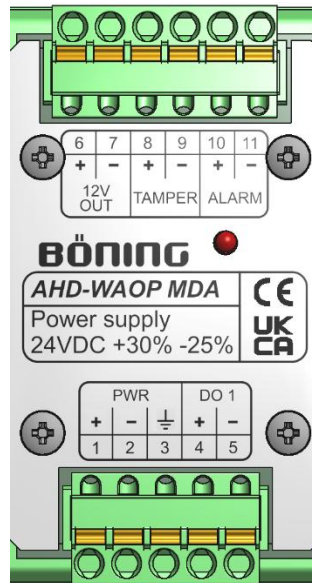

Figure 22: Connection terminals AHD-WAOP MDA

ST6 connector strip			
Terminal	Designation		Description
	1	2	
1	+	PWR	Power supply for AHD-WAOP MD and AHD-WAOP MDA
2	-		
3	EARTH		
4	+	DO 1	Digital output (optocoupler)
5	-		
6	+	12V Out	DC power supply to AHD-WAOP MD, terminals 1 and 2 (positive/negative)
7	-		
8	+	TAMPER	Tamper contact from AHD-WAOP MD, terminals 3 and 4 (TAMPER)
9	-		
10	+	ALARM	Alarm contact from AHD-WAOP MD, terminals 5 and 6 (NC)
11	-		

5 Application examples

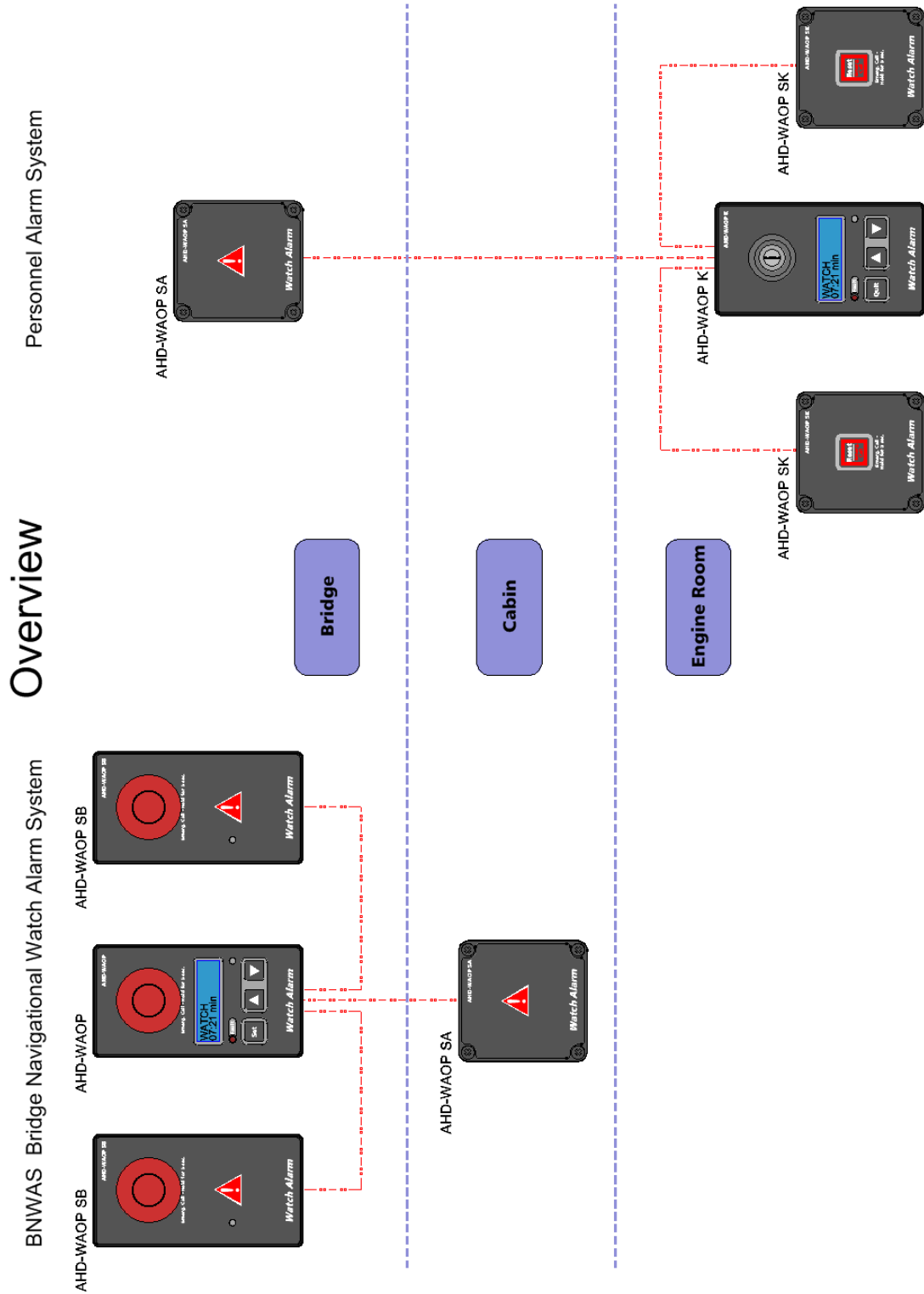

Figure 23: Example 1 - Overview

Application examples

Connection

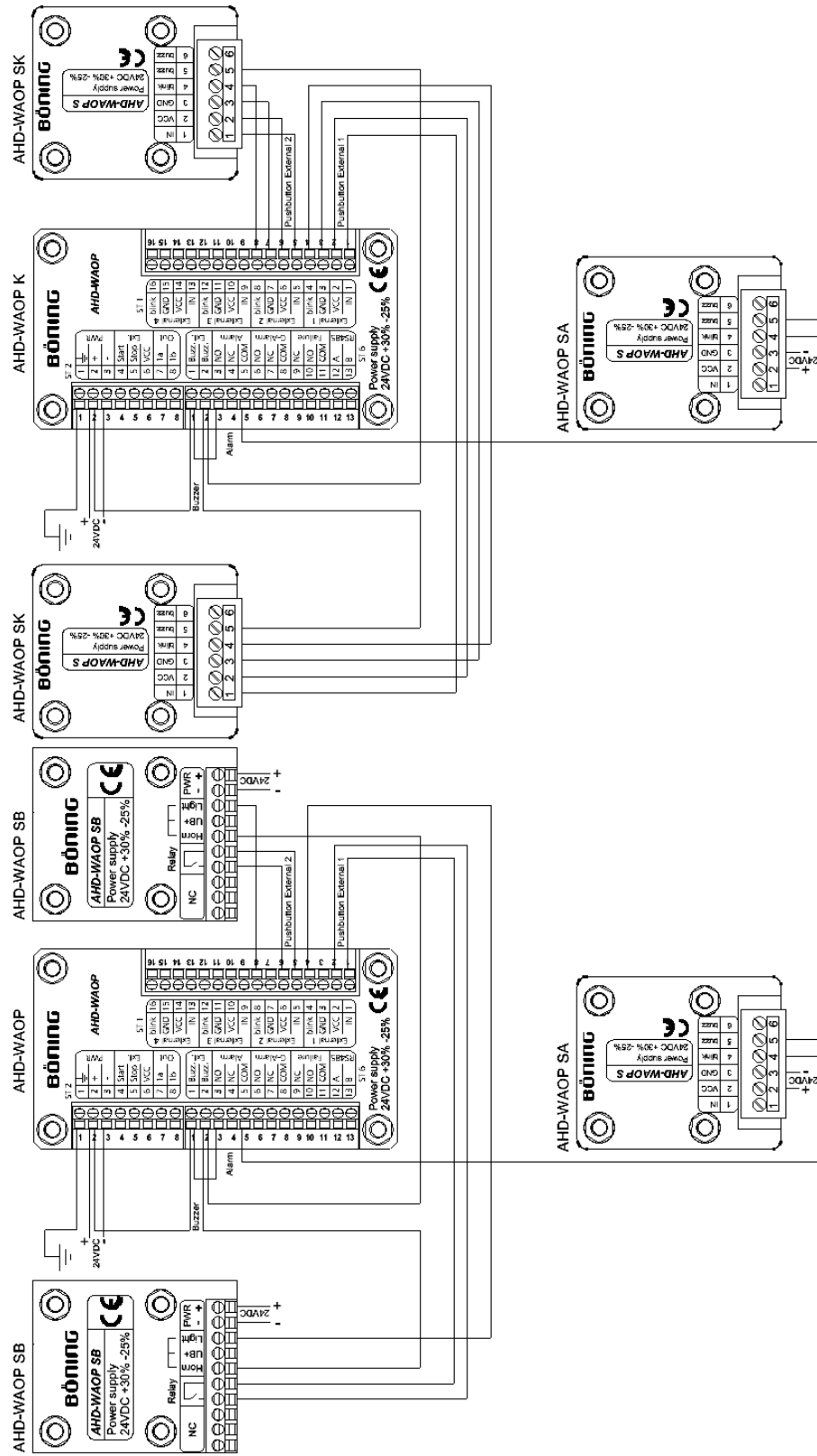

Figure 24: Example 1 - Connection diagram

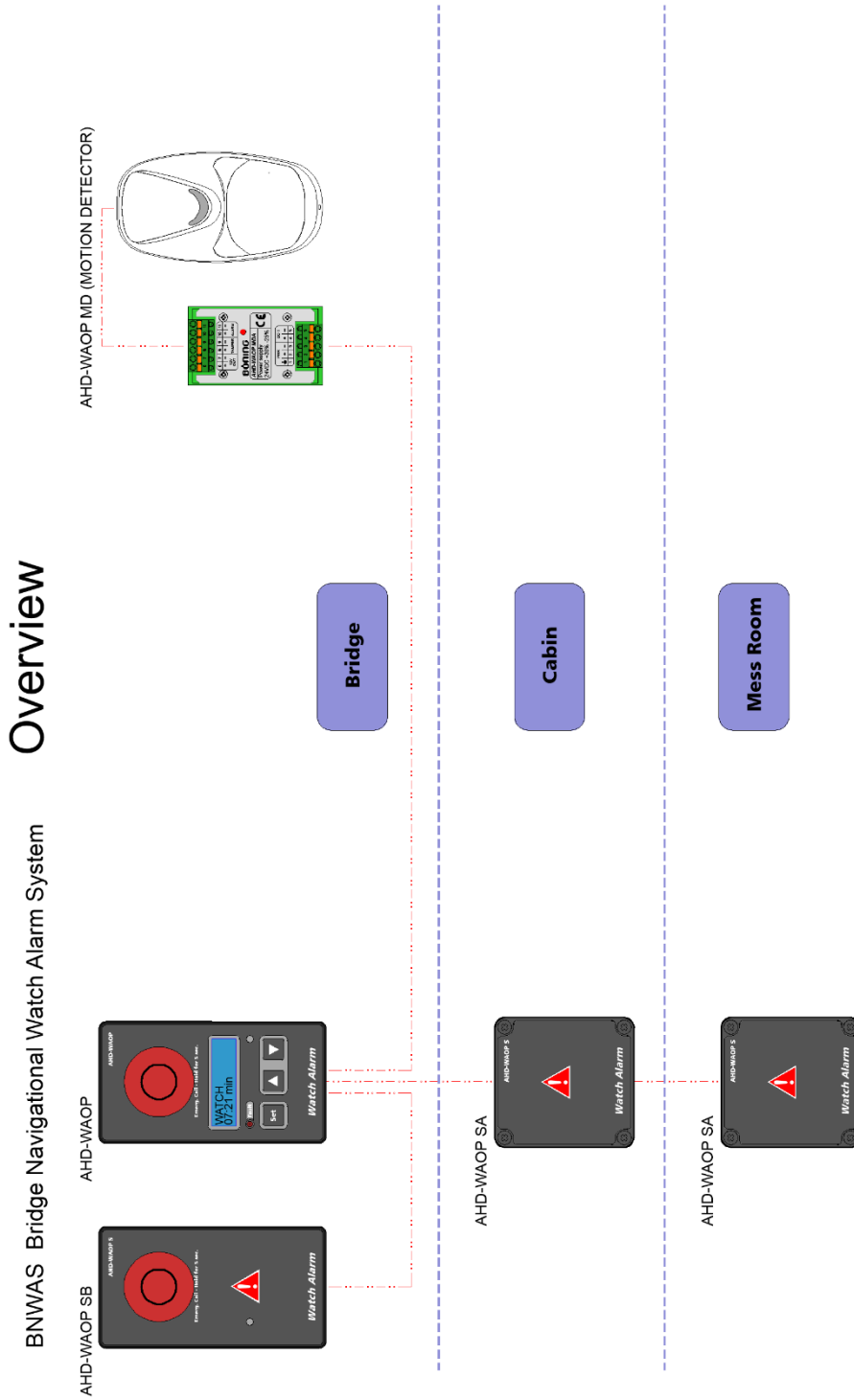

Figure 25: Example 2 – Overview

Application examples

Connection

BNWAS Bridge Navigational Watch Alarm System

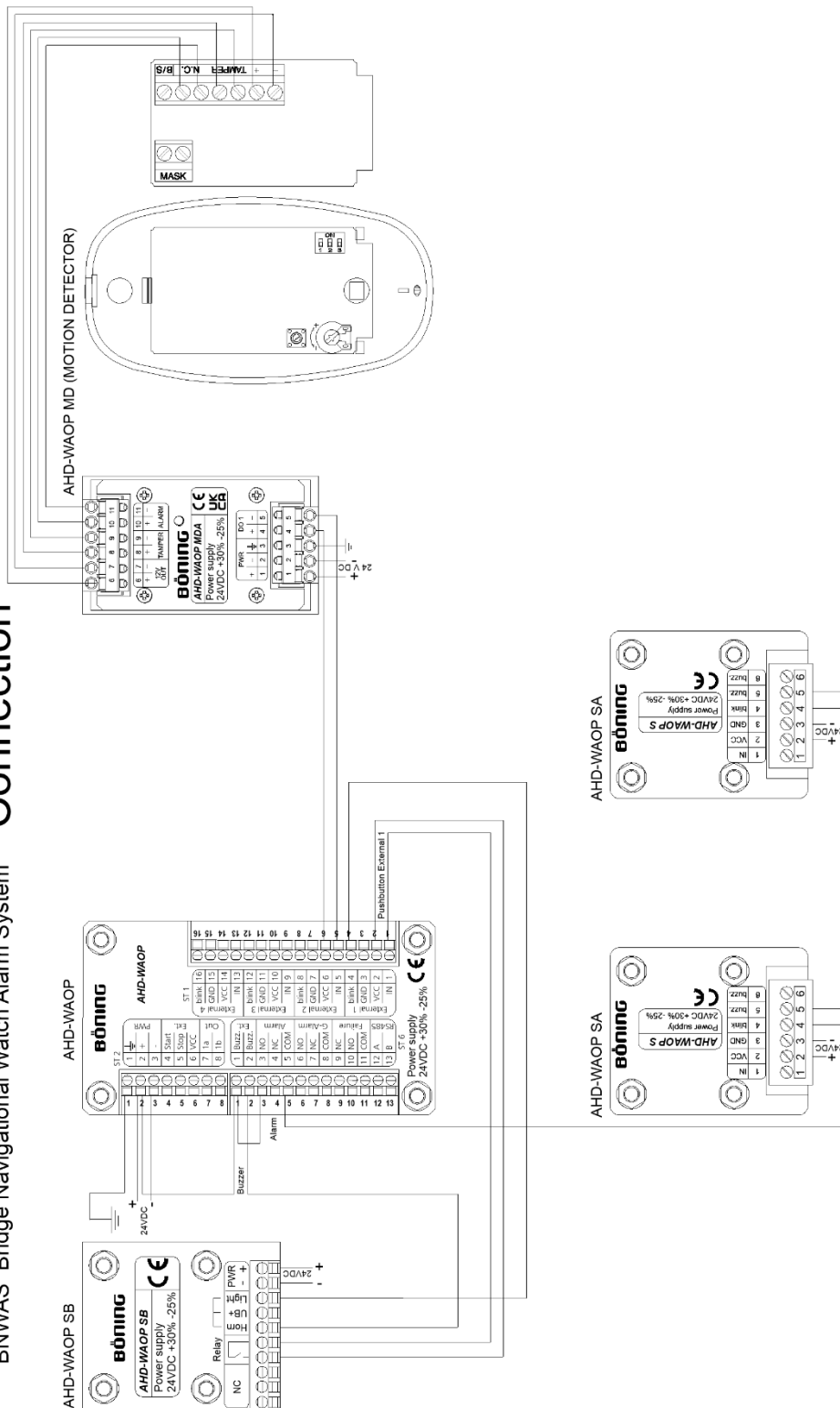

Figure 26: Example 2 – Connection diagram

6 Transport, packaging, and storage

6.1 Safety instructions for transport

Improper transport



CAUTION!

Damage due to improper transport!

Improper transport can result in considerable damage to property.

Therefore:

- Take care when unloading packages upon delivery and during internal transport, and observe the symbols and instructions on the packaging.
- Only remove packaging shortly before assembly.

6.2 Transport inspection

The delivery must be checked immediately upon receipt for completeness and transport damage.

If there is visible transport damage, proceed as follows:

- Do not accept the delivery or only accept it with reservation.
- Note the extent of the damage on the transport documents or on the carrier's delivery note.
- Initiate a complaint.



NOTE!

Report any defects as soon as they are discovered. Claims for damages can only be made within the applicable complaint periods.

6.3 Packaging

About packaging

The individual packages are packed according to the expected transport conditions. Only environmentally friendly materials were used for packaging.

The packaging is designed to protect the individual components from transport damage, corrosion, and other damage until assembly. Therefore, the packaging must not be destroyed and should only be removed shortly before assembly.

Transport, packaging, and storage

Handling packaging materials

The packaging material must be disposed of in accordance with the applicable legal provisions and local regulations.



CAUTION!

Environmental damage due to incorrect disposal!

Packaging materials are valuable raw materials and can in many cases be reused or sensibly processed and recycled.

Therefore:

- Dispose of packaging materials in an environmentally friendly manner.
- Observe the locally applicable disposal regulations. If necessary, commission a specialist company to dispose of the materials.

Storage

Store packages under the following conditions:

- Do not store outdoors.
- Store in a dry and dust-free place.
- Do not expose to aggressive media.
- Protect from sunlight.
- Observe storage temperature (see technical data).
- Avoid mechanical vibrations.
- If stored for longer than 3 months, regularly check the general condition of all parts and the packaging.



NOTE!

Under certain circumstances, the packaging may contain storage instructions that go beyond the requirements specified here. These must be observed accordingly.

7 Installation and initial commissioning

7.1 Safety

Personnel

- Installation and initial commissioning may only be carried out by specially trained personnel.
- Work on the electrical system may only be carried out by qualified electricians.

Basic



Caution!

Risk of injury due to improper installation and initial commissioning!

Improper installation and initial commissioning can result in personal injury or property damage.

Therefore:

- Ensure sufficient space for installation before starting work.
- Handle open, sharp-edged components with care.
- Keep the installation site tidy and clean!
- Install components correctly.

7.2 Installation

7.2.1 installation requirements

According to IEC62616, Annex A: A.1 to A.5, the installation of a Bridge Navigational Watch and Alarm System (BNWAS) certain requirements must be met.

Specifically, the following points must be observed:

- A1: The requirements for a BNWAS system set out in MSC Resolution 128(75), subject area: "Performance Standard for BNWAS" must be complied with.
- A2: Reset buttons may only be installed in locations from which there is a sufficient overview of ship operations and processes.
- A3: Reset options must be installed in the area of the steering position.
- A4: Visual input options for the BNWAS must be clearly visible on the bridge.
- A5: The acoustic BNWAS signaling devices must be installed in such a way that they can be clearly heard throughout the bridge.

Installation and initial commissioning

The positioning and installation of the AHD-WAOP and AHD-WAOP K products must be carried out in accordance with the specifications of MSC/Circ.982. Furthermore, certain specifications must be implemented for the installation of a BNWAS with regard to external wiring:

- The Level 1 audible alarm must have its own tone modulation or characteristic so that it attracts the attention of the OOW (Officer of the Watch).
- The level 2 audible alarm should attract the attention of the master, officers, and other qualified personnel, convey urgency, and wake sleeping qualified personnel. The contents of IMO Resolution A830(19) must also be observed.
- When using supplied reset boxes, it must be ensured that the reset boxes can only be operated by suitable personnel, for example by the OOW. In addition, the reset boxes must be uniform in form and function.
- The BNWAS should be powered by the ship's main power supply. The devices for reporting a BNWAS failure and for reporting an "emergency alarm" must also be kept permanently operational by a battery-backed power supply. This battery-backed power supply must guarantee 6 hours of operation.
- The sound pressure for the level 1 alarm shall be at least 75 dB(A) and at most 85 dB(A) at a distance of one meter from the acoustic source.
- The sound pressure for the level 2 alarm shall be at least 75 dB(A) and at most 120 dB(A) at a distance of one meter from the acoustic source.
- The volume and type of sound modulation or characteristics of the acoustic signaling devices should be variable.

Installation and initial commissioning

7.2.2 Installation of the devices

General



CAUTION!

Property damage due to improper selection of the installation location and handling!

Installing the products in locations that do not meet the requirements of the technical specifications and incorrect handling can lead to system malfunctions and damage to property.

Therefore:

- Observe the technical specifications of the products when selecting the installation location.
- Installation may only be carried out by trained personnel.
- Never install the products in areas that do not comply with the specified protection class.
- Never install the products in areas with extremely high or low temperatures.
- Never install the products on ceilings that cannot support their weight.
- Never subject the products to strong impacts or vibrations.

Installation requirements

- All necessary connection cables are routed to the intended installation location in the required design and with connectors in accordance with the technical specifications or project drawing templates, and are professionally installed and terminated. Free wires have sufficient installation length and are protected against short circuits and ground faults.
- The product is not connected to the supply voltage and is switched off.



CAUTION!

Ground first, then switch on!

Before switching on, ground the device using the grounding terminal provided (terminal 1 on ST2).

Installation

1. Install the AHD-WAOP and AHD-WAOP K products correctly at the intended installation site in accordance with the technical specifications and project drawing templates.
2. Connect all inputs and outputs of the unit in accordance with the drawing templates.

Installation and initial commissioning



CAUTION!

Property damage due to improper cable connections!

Incorrectly connected cables can lead to system malfunctions and damage to property.

Therefore:

- Always check the cable and wire labels before connecting. Check that the connecting wires are securely fastened in the terminal.
- To avoid short circuits, check that all strands are connected in the terminal.
- Do not tighten the terminals too much.
- When connecting plug-in terminal strips or connectors, make sure that they are installed in the correct socket and are securely seated.

3. Check the system for ground/earth faults.



CAUTION!

System failure or malfunction!

In the event of a ground/earth fault, incorrect data may be transmitted, leading to failure or malfunction of the entire system.

Therefore:

- Immediately rectify any earth/ground faults that are detected.

7.3 Initial startup of the

Commissioning requirements

- The AHD-WAOP / AHD-WAOP K is installed correctly and equipped with all necessary connections.
- All external devices connected to the AHD-WAOP / AHD-WAOP K in accordance with the technical specifications or project drawing templates are also installed and ready for operation.
- All necessary power supplies are available and functioning properly.
- The AHD-WAOP / AHD-WAOP K and all connected external devices are not connected to the supply voltage or are disconnected from the power supply.

Installation and initial commissioning



CAUTION!

Ground first, then switch on!

Before switching on, ground the device using the grounding terminal provided for this purpose.

1. Establish the 24 VDC (+30%/-25%) power supply in accordance with the technical specifications or project drawing templates.
2. Establish the power supplies for all external devices connected to the AHD-WAOP / AHD-WAOP K in accordance with the corresponding operating instructions.
3. Check the power supplies.



CAUTION!

Property damage due to incorrect voltage!

Connecting an incorrect supply voltage may result in damage to property.

Therefore:

- Before connecting, review all relevant project documentation and operating instructions for the devices used and check the correct supply voltage and polarity.

4. Switch on the power supply to the AHD-WAOP / AHD-WAOP K and all connected external devices via the corresponding circuit breakers in the power supply distribution system and the device-internal switch-on devices in accordance with the relevant operating instructions.
5. Check that the switch-on process is correct in accordance with the following chapter "Operation".
6. Log any errors or functional deviations that may occur and rectify them by taking appropriate measures, taking into account the faults described in the chapter "Errors."
7. If necessary, check the installed configuration and adapt it to the required operating conditions. Record the final configuration for the project documentation.

Operation

8 Operation

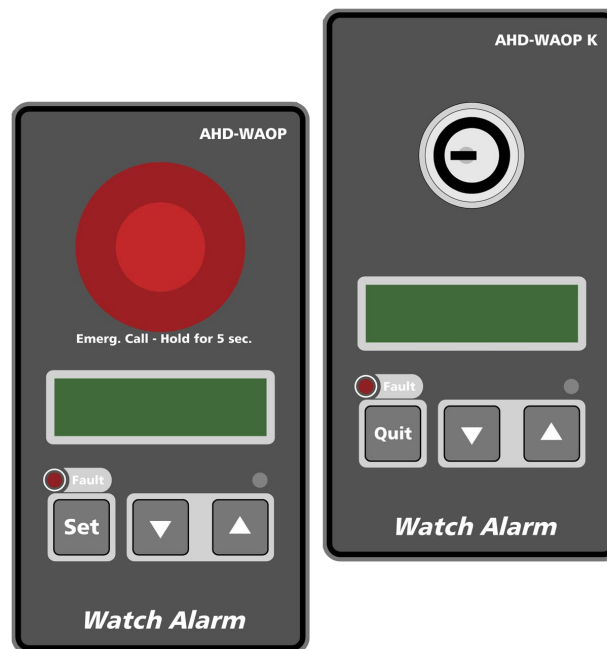

The watch alarm panel AHD-WAOP and the deadman alarm system AHD-WAOP K are considered devices that are relevant for maintaining safety on board the ship.

Various parameters must be configured for the AHD-WAOP and AHD-WAOP K devices, including operating mode and time intervals for acknowledgment and watch rounds.

To ensure that the devices continue to operate with the same settings even after a power failure, the last operating status of the panel is stored internally and restored after restarting. This prevents false alarms and ensures that set guard alarm times or patrol alarm times are not unintentionally changed or reset.

8.1 Switching on

None of the devices belonging to the guard alarm system device family have their own switch for switching on and off. They are activated by switching on their power supply.

Once the power supply has been successfully established, the device controls are illuminated. If the device has an integrated fault LED, this must be switched off.

8.2 Starting and stopping AHD-WAOP

Monitoring of standby mode starts automatically on the AHD-WAOP after the supply voltage is applied, provided that the operating mode has been set to "ON." The monitoring function can be started and stopped manually via the settings menu on the device. Remote control is activated with the "AUTO" operating mode.

The following overview shows the possible operating modes:

- Automatic start after applying the supply voltage in the standard operating mode "ON"
- Manual start by changing the operating mode to "ON" via the device's settings menu (see item 8.7)
- Manual stop by changing the operating mode to "OFF" via the device's settings menu (see item 8.7)
- Remote start and stop by changing the operating mode to "AUTO" via the device's settings menu (see item 8.7)

8.3 Starting and stopping AHD-WAOP K

Monitoring of standby mode is started and stopped on the AHD-WAOP K using the key switch on the front panel. Monitoring can also be started remotely via an external signal.

The following overview shows the possible operating modes:

- Manual start at the beginning of the guard duty by turning the key switch clockwise and then removing the key.
- Manual stopping at the end of the guard duty by inserting the key and turning the key switch counterclockwise.
- Remote start via external signal at the start input (see also item 3.3.2)

8.4 Acknowledging standby mode and alarms

Proper standby mode or a triggered alarm can only be acknowledged on the AHD-WAOP, AHD-WAOP K, or AHD-WAOP SK devices as follows:

- To acknowledge with AHD-WAOP and AHD-WAOP K, any button on the device must be pressed.
- To acknowledge with AHD-WAOP SK, briefly press the "Reset Emerg. Call" button.

Operation

8.5 Triggering an emergency call

Emergency calls can only be triggered on the AHD-WAOP, AHD-WAOP SB, or AHD-WAOP SK devices.

- To trigger an emergency call with AHD-WAOP and AHD-WAOP SB, press and hold the mushroom button on the front of the device for at least 5 seconds.
- To trigger an emergency call with AHD-WAOP SK, press and hold the "Reset Emerg. Call" button for at least 5 seconds.

8.6 Ending an emergency call

To end an emergency call via the AHD-WAOP and AHD-WAOP SB devices, briefly press the mushroom button on the device once.

To end an emergency call with AHD-WAOP SK, press the "Reset Emerg. Call" button once briefly.

8.7 AHD-WAOP settings menu



Figure 27: WAOP Setting Menu

Menu call

To call up the menu, press and hold the UP and DOWN buttons (5 and 6) must be pressed together for at least 5 seconds.



NOTE!

If no input is made within a period of more than 3 seconds, the device will exit the menu function and the display will automatically return to the start screen.

Enter password

A password prompt appears on the display. The factory default code is set to <0000>. Press the UP or DOWN button to change the selected digit. Press the Reset button (4) to move the cursor to the next digit. Once the password has been entered correctly, the menu for entering the runtime appears.

Set elapsed time

Here, the elapsed time can be set between 3:00 minutes (minimum) and 12:00 minutes (maximum) in increments of 15 seconds using the UP and DOWN buttons. Pressing the reset button confirms the current time setting and calls up the menu for selecting the operating mode.

Setting the operating mode

The operating mode is set to <OFF> by default, so that the device is deactivated after switching on. To activate the timer, press the UP button once so that <ON> appears on the display. After confirming with the Reset button and exiting the menu, the AHD WAOP is "armed."

Alternatively, the AUTO operating mode can be selected. In this mode, the monitoring function is switched on and off via an external signal transmitter (see item 0). This mode must also be confirmed by pressing the reset button.

Change password

The password can be changed in the last menu item. The default display in the query is <NO>. Pressing the reset button, this position is skipped, meaning no change is made.

To change the password, press the UP button once. The display will now show <YES>. After confirming with the reset button, you can now define a new password. To do this, change the selected position using the UP and DOWN buttons and then confirm again with the reset button.

Exiting the menu

Before exiting the settings menu, the device displays the current software version and then starts in the set operating mode.

Operation



NOTE!

Pressing the mushroom button on the AHD-WAOP for at least 5 seconds triggers an emergency call. All alarm outputs except the general alarm are activated immediately. The general alarm follows after a delay of 90 seconds if the emergency call is not acknowledged.

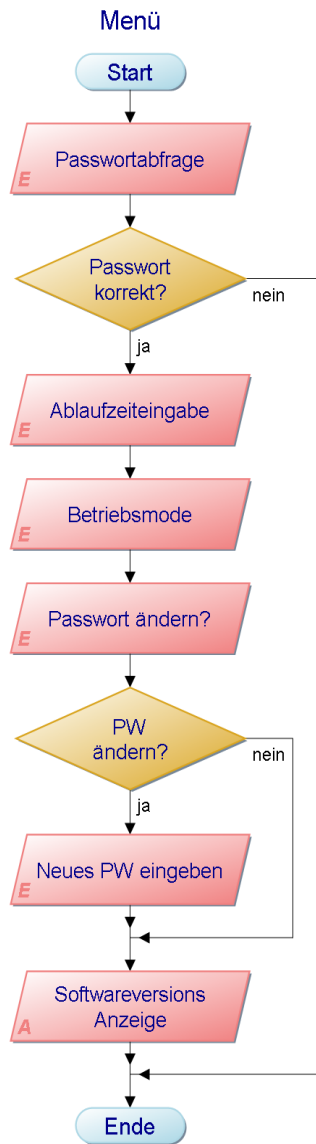

Figure 28: WAOP menu structure



NOTE!

The emergency call alarm can also be triggered via the mushroom button in the settings menu.

8.8 Setting menu AHD-WAOP K



Figure 29: WAOP K settings menu

Menu call

To call up the menu, the UP and DOWN buttons (5 and 6) must be pressed together for at least 5 seconds.



NOTE!

The menu can only be called up if the switch key has been inserted and turned to the <ON> position (counterclockwise).



NOTE

If no input is made within a period of more than 3 seconds, the device exits the menu function and the display automatically returns to the start screen.

Enter password

A password prompt appears on the display. The factory default code is set to <0000>. Press the UP or DOWN button to change the selected digit. Press the reset button (4) to move the cursor to the next digit. Once the password has been entered correctly, the menu for entering the runtime appears.

Set the elapsed time

Here, the timeout can be set between 3:00 minutes (minimum) and 30:00 minutes (maximum) in increments of 15 seconds using the UP and DOWN buttons.

Operation

Pressing the QUIT button confirms the current time setting and calls up the menu item for changing the password. The default display is <NO>. Pressing the reset button skips this position, i.e., no change is made.

Change password

To change the password, press the UP button once. The display will now show <YES>. After confirming with the reset button, you can now define a new password. To do this, change the selected position using the UP and DOWN buttons and then confirm again with the reset button.

Exiting the menu

Before exiting the settings menu, the device displays the current software version and then starts in the set operating mode.

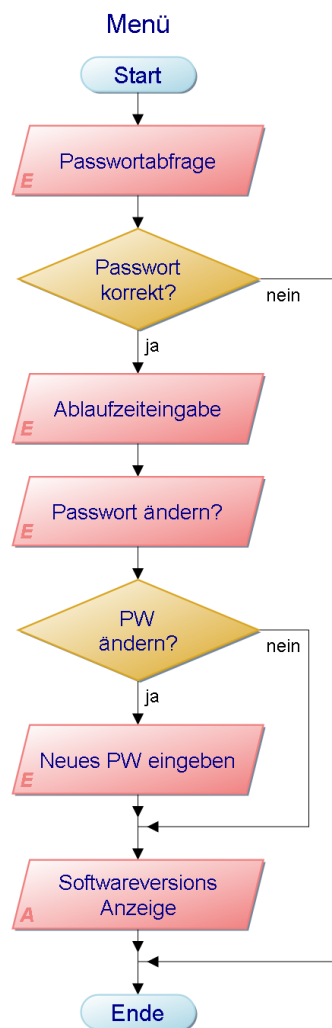

Figure 30: WAOP K menu structure

8.9 Automatic dimming

All AHD-WAOP, AHD-WAOP K, and AHD-WAOP SB bridge installation devices have an integrated photosensor so that the brightness of the panel lighting (display, buttons, and indicator lights) can be automatically adjusted to the ambient lighting conditions. This ensures glare-free operation even in the dark.

8.10 Switching off



NOTE!

As the panels do not have a power button, they are switched off by disconnecting the power supply via the corresponding fuse switch.

9 Maintenance



NOTE

The AHD-WAOP and AHD-WAOP K panels are generally maintenance-free.

Maintenance of the units is limited to external cleaning and inspection.

Only use solvent-free and scratch-free cleaning agents for cleaning.



CAUTION!

Risk of injury due to dangerous voltages or other hazards

When opening covers, you may be exposed to dangerous voltages or other risks.

Therefore:

- Never repair the device yourself.
- Do not open covers for servicing or inspection.
- In the event of product malfunctions, contact the manufacturer or its authorized representative.

Malfunctions

10 Malfunctions

The following table describes possible malfunctions during operation of the AHD-WAOP and AHD-WAOP K panels, with information on the cause, fault detection, and troubleshooting.

10.1 Safety

Personnel

- Some work may only be carried out by specially trained personnel or exclusively by the manufacturer; this is indicated separately in the description of the individual faults.
- Work on the electrical system may only be carried out by qualified electricians.

Basic information



CAUTION!

Risk of injury due to dangerous voltages or other hazards

When opening covers, you may be exposed to dangerous voltages or other risks.

Therefore:

- Never repair the device yourself.
- Do not open covers for servicing.



WARNING!

Risk of injury due to improper troubleshooting!

Improper troubleshooting can result in serious personal injury or property damage.

Therefore:

- Repairs to the device may only be carried out by the manufacturer or authorized personnel.
- Ensure sufficient space for installation before starting work.
- Keep the installation site tidy and clean! Loose components and tools lying around are a potential source of accidents.
- If components have been removed, ensure correct installation, reinstall all fasteners, and observe the screw tightening torques.

What to do in case of malfunctions

The following applies in all cases:

1. Determine the cause of the malfunction.
2. Immediately inform the person responsible at the site of the malfunction.
3. Depending on the type of malfunction, have it repaired by authorized personnel or repair it yourself.
4. Rectify the fault by replacing or repairing the faulty parts (e.g., cables, plugs, etc.).
5. If the fault cannot be determined using the fault table, it cannot be ruled out that the device is defective. To have it repaired, send the device to the manufacturer's address or to an authorized specialist company.

10.2 Fault LED

	Permanently ON	Permanently OFF	Flashing
Fault LED	Device is defective. Please return to the manufacturer for diagnosis.	Device is functioning properly.	N/A

10.3 Troubleshooting

Malfunction	Possible cause	Error detection/remedy
No backlight	No power supply	Check power supply and cables.
Brightness control not working	Opening for photosensor is covered or dirty	Check photosensor in darkness, change after illuminating with flashlight
Device cannot be programmed.	Key removed (AHD-WAOP K) Incorrect password entered	Insert key and turn counterclockwise. Enter the correct password.

Disassembly

11 Disassembly

Once the end of its useful life has been reached, the device must be dismantled and disposed of in an environmentally friendly manner.

11.1 Safety

Personnel

- Disassembly may only be carried out by specially trained personnel.
- Work on the electrical system may only be carried out by qualified electricians.

Basic



Caution!

Risk of injury if disassembly is carried out incorrectly!

Stored residual energy, sharp components, points, and corners on and in the device or on the tools required can cause injuries.

Therefore:

- Ensure there is sufficient space before starting work.
- Handle open, sharp-edged components with care.
- Keep your workplace tidy and clean! Loose components and tools lying around are a potential source of accidents.
- Disassemble components properly.
- If you are unsure, consult the manufacturer.

Procedure

- Before starting disassembly: Disconnect the device from the power supply and secure it against being switched back on.
- Disconnect cable connections and mark them if necessary. Protect exposed wire ends against short circuits and ground/earth faults.
- Loosen the device fastenings.
- Remove the device using appropriate measures.
- Clean the device for disposal and dismantle it in accordance with applicable occupational safety and environmental protection regulations.

11.2 Disposal

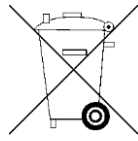

If no take-back or disposal agreement has been made, recycle dismantled components:

- Scrap metals.
- Recycle plastic elements.
- Dispose of remaining components sorted by material type.



CAUTION!

Environmental damage if disposed of incorrectly!

Electrical waste, electronic components, lubricants, and other auxiliary materials are subject to special waste treatment and may only be disposed of by authorized specialist companies!

The local municipal authority or specialist disposal companies can provide information on environmentally friendly disposal.

List of figures

12 List of figures

<i>Figure 1: AHD-WAOP Front view</i>	15
<i>Figure 2: AHD-WAOP warning levels</i>	17
<i>Figure 3: AHD-WAOP K front view</i>	19
<i>Figure 4: AHD-WAOP K warning levels</i>	20
<i>Figure 5: AHD-WAOP SB front view</i>	24
<i>Figure 6: AHD-WAOP SA built-in device</i>	25
<i>Figure 7: AHD-WAOP SA AP surface-mounted device</i>	25
<i>Figure 8: AHD-WAOP SK built-in device</i>	25
<i>Figure 9: AHD-WAOP SK AP surface-mounted device</i>	25
<i>Figure 10: AHD-WAOP MD motion detector (similar to illustration) with AHD-WAOP MDA adapter</i>	26
<i>Figure 11: AHD-WAOP dimensions</i>	27
<i>Figure 12: Dimensions AHD-WAOP K</i>	28
<i>Figure 13: Dimensions AHD-WAOP SB</i>	29
<i>Figure 14: Dimensions AHD-WAOP SA (built-in version)</i>	30
<i>Figure 15: Dimensions AHD-WAOP SA AP (surface-mounted version)</i>	31
<i>Figure 16: Dimensions AHD-WAOP SK (built-in version)</i>	32
<i>Figure 17: Dimensions AHD-WAOP SK AP (surface-mounted version)</i>	32
<i>Figure 18: Dimensions of AHD-WAOP MD (illustration may vary)</i>	34
<i>Figure 19: Dimensions of AHD-WAOP MDA (adapter)</i>	34
<i>Figure 20: Connection terminals AHD-WAOP / AHD-WAOP K</i>	35
<i>Figure 21: Connection terminal ST6 (AHD-WAOP / AHD-WAOP K)</i>	37
<i>Figure 22: Connection terminals AHD-WAOP MDA</i>	38
<i>Figure 23: Example 1 - Overview</i>	39
<i>Figure 24: Example 1 - Connection diagram</i>	40
<i>Figure 25: Example 2 – Overview</i>	41
<i>Figure 26: Example 2 – Connection diagram</i>	42
<i>Figure 27: WAOP Setting Menu</i>	52
<i>Figure 28: WAOP menu structure</i>	54
<i>Figure 29: WAOP K settings menu</i>	55
<i>Figure 30: WAOP K menu structure</i>	56



Devices, plant engineering, monitoring and
control technology, ship automation

Böning Automation Technology GmbH & Co. KG
Am Steenöver 4
D-27777 Ganderkesee
Email: info@boening.com
Website: www.boening.com
Text and illustrations are not binding.
Subject to change due to technical progress.