

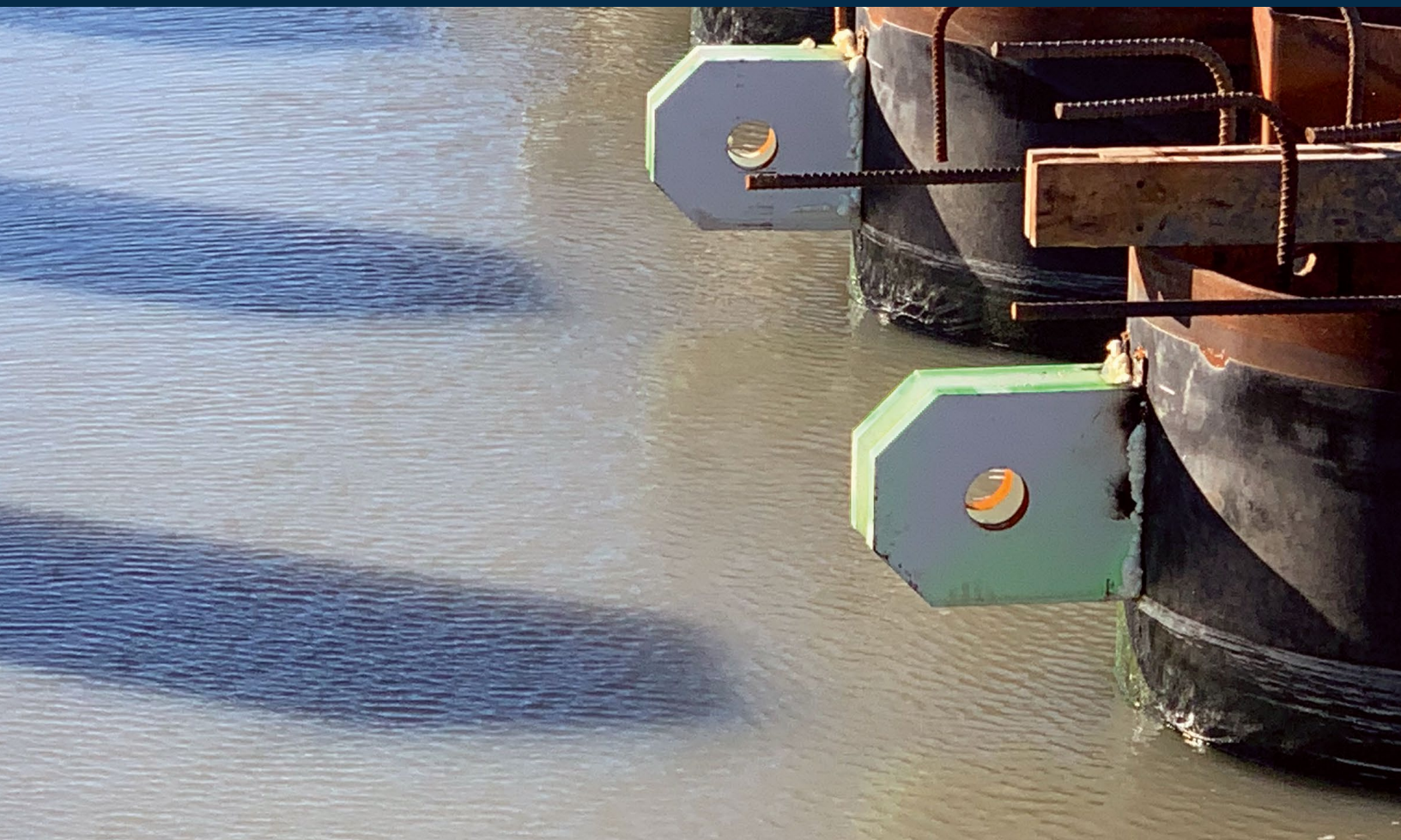

GEOSTRUCTURALS



TIE RODS

KEY FEATURES

Tie Rods produced from THREADBAR® are used for marine bulkheads, docking facilities, barge and ship docks as well as offshore platforms. They are a cost effective alternative to large diameter A36 Tie Rods with upset threads.

Continuous, coarse thread allows for rough site handling and for easy on site length adjustments since cutting or coupling of the rod is possible along its entire length.

CORROSION PROTECTION OPTIONS

- Double Corrosion Protection (DCP)
- Hot dip galvanizing
- Epoxy coating
- Tape coating

TIE ROD WITH DOUBLE CORROSION PROTECTION (DCP)

Recommended for permanent applications in aggressive environments

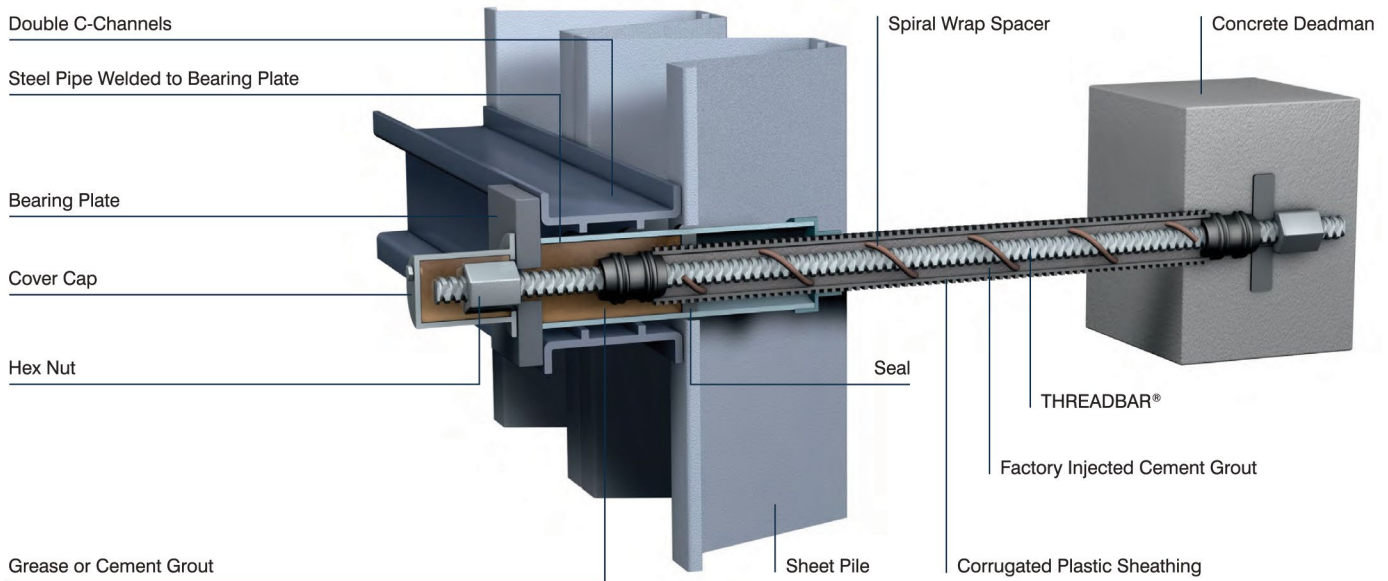

WALER CONNECTION

Short bolts are needed to connect a standard sheet pile wall or a modular sheet pile wall to a load distributing double channel beam. This can be done with Grade 75 or Grade 80 THREADBAR®.

The required length of the bar depends on the depth of the sheet pile profile, the width of the beam, the plate thickness and the nut length.

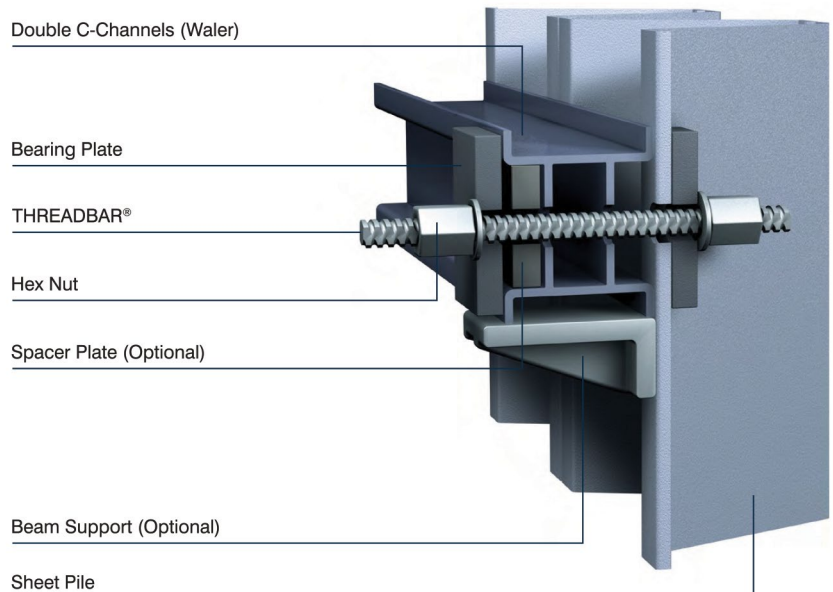

THREADBAR® REINFORCING SYSTEMS

TIE ROD CONNECTIONS

Anchorage in different variations for steel and concrete structures

- Clevis connection
- Eye anchor connection
- Welded connection
- Embedded connection
- Plate-nut connection

FEATURES

- Articulated
- Angle compensating
- Self-aligning under load
- Tensionable

COUPLERS AND CONNECTIONS

COUPLER



TURNBUCKLE



DOUBLE EYE ANCHOR CONNECTION

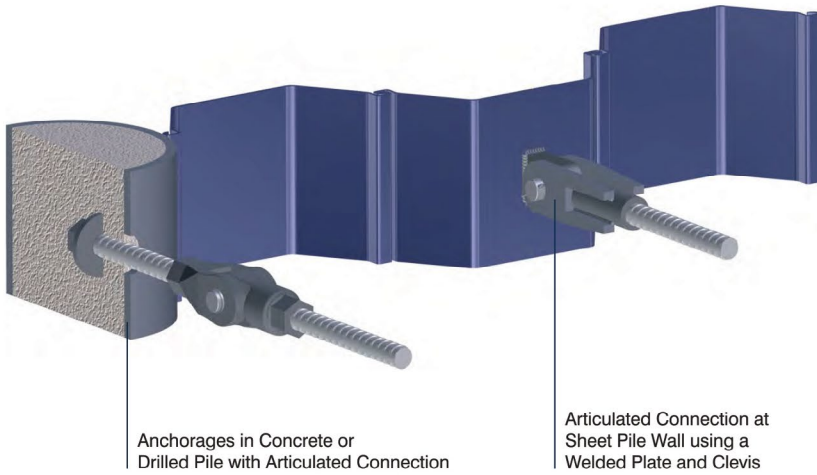
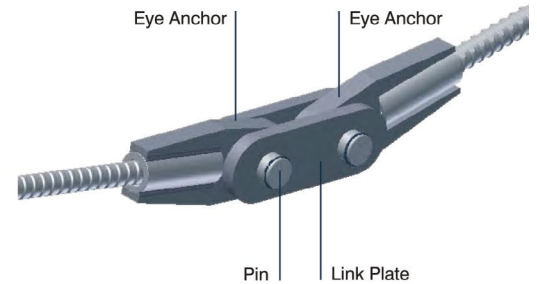

GRADE 75, 80 & 100 THREADBAR® – REINFORCING STEEL PER ASTM A615

THREADBAR® Designation	Maximum THREADBAR® Diameter			Minimum Yield Stress (f_y)		Nominal Cross Section Area (A_s)		Minimum Yield Load ($f_y \times A_s$)		Nominal Weight	
	mm	in	mm	ksi	MPa	in ²	mm ²	kips	kN	lbs/ft	kg/m
GRADE 75 and 80											
#6	19	0.86	22	75	517	0.44	284	33.0	147	1.50	2.23
#7	22	0.99	25	75	517	0.60	387	45.0	200	2.04	3.04
#8	25	1.12	28	75	517	0.79	510	59.3	264	2.67	3.97
#9	29	1.26	32	75	517	1.00	645	75.0	334	3.40	5.06
#10	32	1.43	36	75	517	1.27	819	95.3	424	4.30	6.40
#11	36	1.61	41	75	517	1.56	1,006	117.0	520	5.31	7.90
#14	43	1.86	47	80	552	2.25	1,452	180.0	801	7.65	11.38
#18	57	2.50	64	80	552	4.00	2,581	320.0	1,423	13.60	20.24
#20	63	2.72	69	80	552	4.91	3,168	393.0	1,748	16.70	24.85
#24 ¹⁾	75	3.18	81	75	517	7.06	4,555	529.5	2,355	24.09	35.85
#28 ¹⁾	90	3.68	94	75	517	9.62	6,206	721.5	3,209	32.79	48.80
GRADE 100											
#6	19	19	22	100	689	0.44	284	44.0	196	1.50	2.23
#7	22	22	25	100	689	0.60	387	60.0	267	2.04	3.04
#8	25	25	28	100	689	0.79	510	79.0	351	2.67	3.97
#9	29	29	32	100	689	1.00	645	100.0	445	3.40	5.06
#10	32	32	36	100	689	1.27	819	127.0	565	4.30	6.40
#11	36	36	41	100	689	1.56	1,006	156.0	694	5.31	7.90
#14	43	43	47	100	689	2.25	1,452	225.0	1,001	7.65	11.38
#18	57	57	64	100	689	4.00	2,581	400.0	1,779	13.60	20.24
#20	63	63	69	100	689	4.91	3,168	491.0	2,184	16.70	24.85

Note: Maximum allowable temporary tension is 90% of yield load. Mill length is 60 ft (#6 through #20) and 53 ft for #24 and #28.

¹⁾ Threadbar sizes not listed by ASTM A 615 but yield strength is in conformance with A615 standard.

THREADBAR® REINFORCING SYSTEMS

INTRODUCTION

THREADBAR® Reinforcing Steel is available in Grades 75, 80, 100 for sizes #6 through #20, and Grade 75 to #24 and #28. Threadbars conform to the requirements of ASTM A615, except in markings. Threadbars may be shipped to the job in mill lengths or fabricated to specifications.

THREADBAR® Reinforcing Steel has a continuous rolled-in pattern of thread-like deformations along its entire length. More durable than machined threads, the deformations allow nuts couplers to thread onto a Threadbar at any point along its length.

Threadbars may be epoxy coated in accordance with ASTM A775 or galvanized in accordance to ASTM A123. Threaded accessories for coated bars thread over the coating.

ADVANTAGES OF HIGH-STRENGTH THREADBAR® REINFORCEMENT

- Fewer bars to handle
- Less congestion
- Lighter reinforcement assemblies
- Faster construction
- Easy to install coupler system
- Can replace rebar terminator with a bearing plate with top and bottom nuts

Having to hoist, handle and place a lower volume of reinforcing steel makes installation simpler and faster. And, less congestion results in higher quality concrete placement with reduced risk of consolidation issues. All these advantages result in a reduced volume of steel and shorter construction time leading to a lower overall cost of the reinforced concrete structure.

FIELDS OF APPLICATION

- Concrete reinforcement
- Micropiles
- Auger cast piles
- Caissons
- Drilled shafts

THREADBAR® PROPERTIES – REINFORCING STEEL PER ASTM A615R

THREADBAR® Designation	Maximum THREADBAR® Diameter			Minimum Yield Stress (f_y)		Nominal Cross Section Area (A_g)		Minimum Yield Load ($f_y \times A_g$)		Nominal Weight	
	mm	in	mm	ksi	MPa	in ²	mm ²	kips	kN	lbs/ft	kg/m
GRADE 75, 80 THREADBAR®											
#6	19	0.86	22	75	517	0.44	284	33.0	147	1.50	2.23
#7	22	0.99	25	75	517	0.60	387	45.0	200	2.04	3.04
#8	25	1.12	28	75	517	0.79	510	59.3	264	2.67	3.97
#9	29	1.26	32	75	517	1.00	645	75.0	334	3.40	5.06
#10	32	1.43	36	75	517	1.27	819	95.3	424	4.30	6.40
#11	36	1.61	41	75	517	1.56	1,006	117.0	520	5.31	7.90
#14	43	1.86	47	80	552	2.25	1,452	180.0	801	7.65	11.38
#18	57	2.50	64	80	552	4.00	2,581	320.0	1,423	13.60	20.24
#20	63	2.72	69	80	552	4.91	3,168	393.0	1,748	16.70	24.85
#24 ¹⁾	75	3.18	81	75	517	7.06	4,555	529.5	2,355	24.09	35.85
#28 ¹⁾	90	3.68	94	75	517	9.62	6,206	721.5	3,209	32.79	48.80
GRADE 100 THREADBAR®											
#6	19	0.86	22	100	689	0.44	284	44.0	196	1.50	2.23
#7	22	0.99	25	100	689	0.60	387	60.0	267	2.04	3.04
#8	25	1.12	28	100	689	0.79	510	79.0	351	2.67	3.97
#9	29	1.26	32	100	689	1.00	645	100.0	445	3.40	5.06
#10	32	1.43	36	100	689	1.27	819	127.0	565	4.30	6.40
#11 ²⁾	36	1.61	41	100	689	1.56	1,006	156.0	694	5.31	7.90
#14 ²⁾	43	1.86	47	100	689	2.25	1,452	225.0	1,001	7.65	11.38
#18 ²⁾	57	2.50	64	100	689	4.00	2,581	400.0	1,779	13.60	20.24
#20 ²⁾	63	2.72	69	100	689	4.91	3,168	491.0	2,184	16.70	24.85

Note: Mill length is 60 ft (#6 through #20) and 53 ft for #24 and #28.

¹⁾ Threadbar sizes not listed by ASTM A 615 but yield strength is in conformance with A615 standard.

²⁾ #11, #14, #18 and #20 Threadbars and their Couplers have ICC-ES Evaluation Report Approval ESR-3367.

THREADBAR® REINFORCING SYSTEMS

COUPLER SYSTEM

Couplers and hex nuts develop the full ultimate load of the Threadbar. Slippage of the coupler under stress is controlled by torquing opposing Threadbars together or by using nuts. The magnitude of the torque required varies with the allowable slip and Threadbar size.

The THREADBAR® reinforcing system offers a simple, reliable and economical splice. A splice requires less crane time and less labor time for assembly than required for other splices.

Unlike some splices, the splice may be installed in adverse weather conditions and does not create a fire hazard. Opposing Threadbars need only to be chalk marked before assembly to assure proper engagement, supervision and quality control requirements are minimized.

COUPLER WITH HEXNUTS

When opposing threadbars are not torqued together, hex nuts will be used on each end of the coupler and tightened against the coupler.

The splice will develop the full ultimate load of the bar in tension and compression.

COUPLER WITH LOCKNUTS

Locknuts can also be used each side end of the coupler similar to hex nuts. The splice will develop the full load ultimate load of the bar in tension and about half the ultimate load in compression.

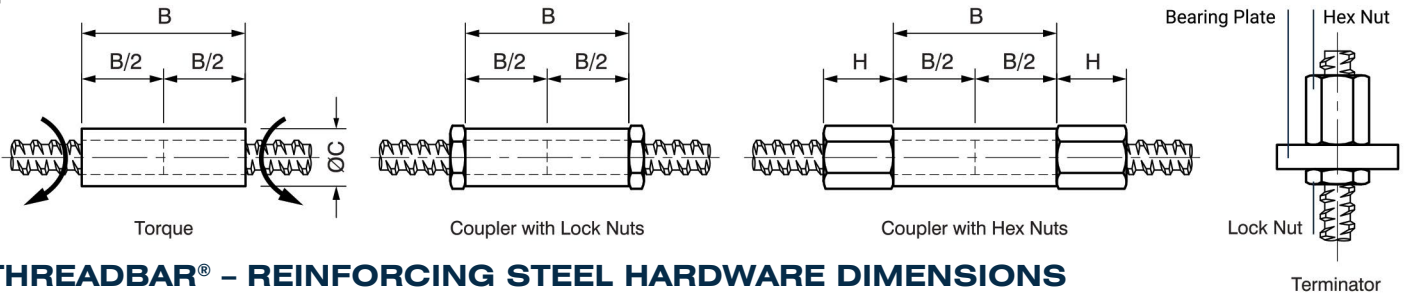

THREADBAR® – REINFORCING STEEL HARDWARE DIMENSIONS

THREADBAR® Designation	Hexnut Length H		Coupler Length B		Coupler Outer Diameter ØC	
	in	mm	in	mm	in	mm
GRADE 75, 80 THREADBAR®						
#6	1.43	36	3.12	79	1.22	31
#7	1.71	43	3.73	95	1.41	36
#8	1.84	47	4.03	102	1.59	40
#9	2.30	58	5.02	128	1.79	45
#10	2.56	65	5.70	145	2.02	51
#11	2.89	73	6.37	162	2.25	57
#14	3.55	90	7.82	199	2.65	67
#18	4.23	107	9.35	237	3.50	89
#20	4.85	123	10.38	264	3.86	98
"#24	4.10	104	9.20	234	4.75	121
#28	4.80	122	10.61	269	5.38	137
GRADE 100 THREADBAR®						
#6	2.88	73	6.25	159	1.25	32
#7	3.13	80	7.00	178	1.50	38
#8	3.38	86	7.13	181	1.75	44
#9	3.50	89	7.25	184	1.88	48
#10	3.75	95	7.50	191	2.13	54
#11	3.88	99	8.00	203	2.38	60
#14	4.50	114	8.25	210	2.75	70
#18	5.25	133	10.50	267	3.63	92
#20	6.00	152	12.25	311	4.00	102



THREADBAR® SOIL NAIL WITH DCP FOR THE MOST AGGRESSIVE SOIL CONDITIONS

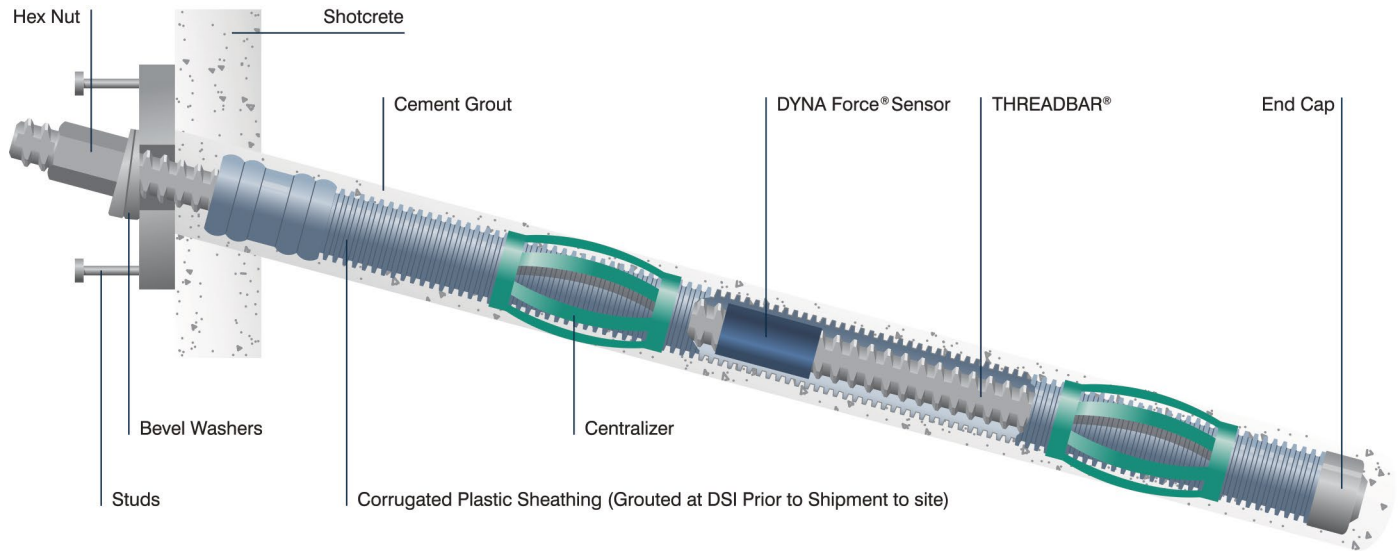

THREADBAR® SOIL NAIL - BARE, EPOXY COATED OR GALVANIZED

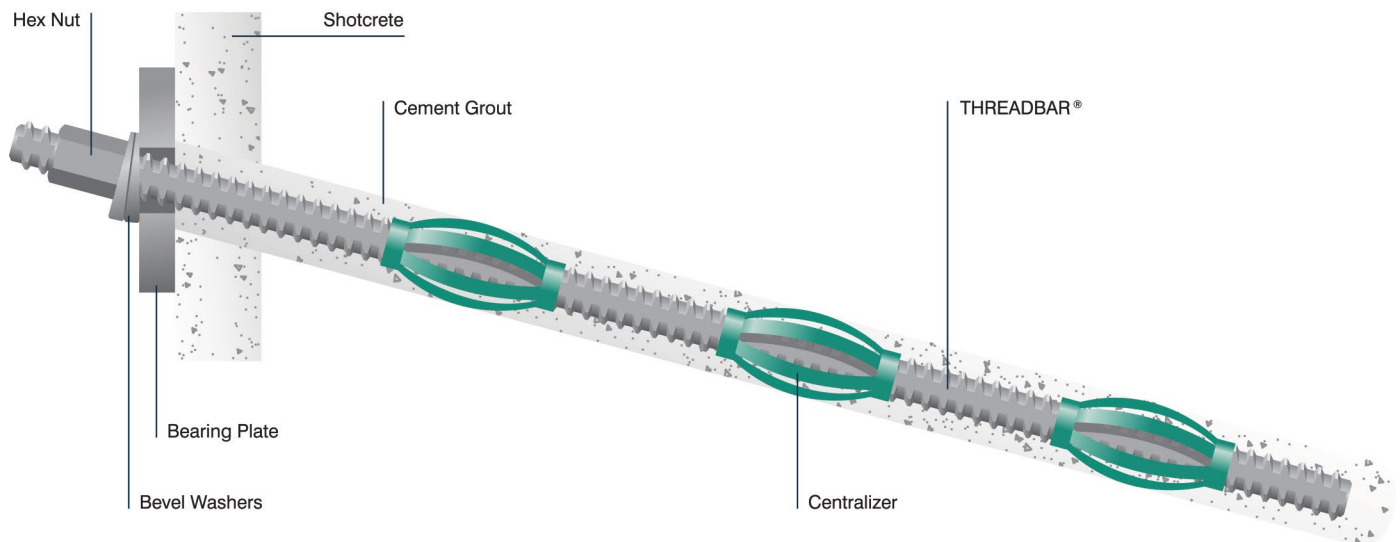

SOIL NAILS

KEY FEATURES

- Top-down construction
- Lower construction costs versus tieback walls with soldier beams and lagging
- Can be used for temporary and permanent applications
- Simple components and assembly
- Easy to install and test
- Durable full length threads allow for cutting and coupling the bar at any point along its length

GRADE 75, 80 & 100 THREADBAR® – REINFORCING STEEL PER ASTM A615

THREADBAR® Designation	Maximum THREADBAR® Diameter			Minimum Yield Stress (f_y)		Nominal Cross Section Area (A_s)		Minimum Yield Load ($f_y \times A_s$)		Nominal Weight	
	mm	in	mm	ksi	MPa	in ²	mm ²	kips	kN	lbs/ft	kg/m
Grade 75 and 80 ¹⁾											
#6	19	0.86	22	75	517	0.44	284	33.0	147	1.50	2.23
#7	22	0.99	25	75	517	0.60	387	45.0	200	2.04	3.04
#8	25	1.12	28	75	517	0.79	510	59.3	264	2.67	3.97
#9	29	1.26	32	75	517	1.00	645	75.0	334	3.40	5.06
#10	32	1.43	36	75	517	1.27	819	95.3	424	4.30	6.40
#11	36	1.61	41	75	517	1.56	1,006	117.0	520	5.31	7.90
#14	43	1.86	47	80	552	2.25	1,452	180.0	801	7.65	11.38
Grade 100											
#6	19	0.86	22	100	689	0.44	284	44.0	196	1.50	2.23
#7	22	0.99	25	100	689	0.60	387	60.0	267	2.04	3.04
#8	25	1.12	28	100	689	0.79	510	79.0	351	2.67	3.97
#9	29	1.26	32	100	689	1.00	645	100.0	445	3.40	5.06
#10	32	1.43	36	100	689	1.27	819	127.0	565	4.30	6.40
#11	36	1.61	41	100	689	1.56	1,006	156.0	694	5.31	7.90
#14	43	1.86	47	100	689	2.25	1,452	225.0	1,001	7.65	11.38

¹⁾ Note: Maximum allowable temporary tension is 90% of minimum yield load.
Mill length is 60 ft.



THREADBAR® with Centralizer

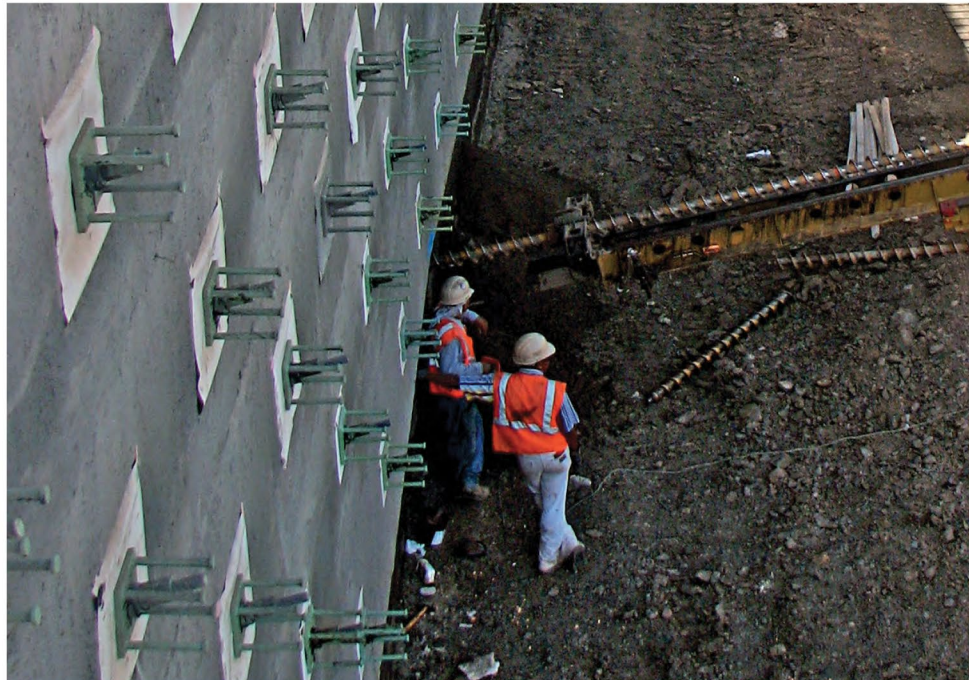

THREADBAR® ANCHORS

KEY FEATURES

- Threadbars with proven coarse thread along the entire length. Bar
- length can be adjusted on site without any problems
- Variable anchor head and angle compensation designs
- Easy handling, tensioning, retensioning or detensioning
- Can be utilized for fully or partially removable anchors
- Can be supplied with Double Corrosion
- Protection (DCP) for permanent applications

FIELDS OF APPLICATION

- Excavations
- Tiebacks
- Rock and slope stabilization
- Tiedown anchors

THREADBAR® ANCHOR – PERMANENT (DCP)

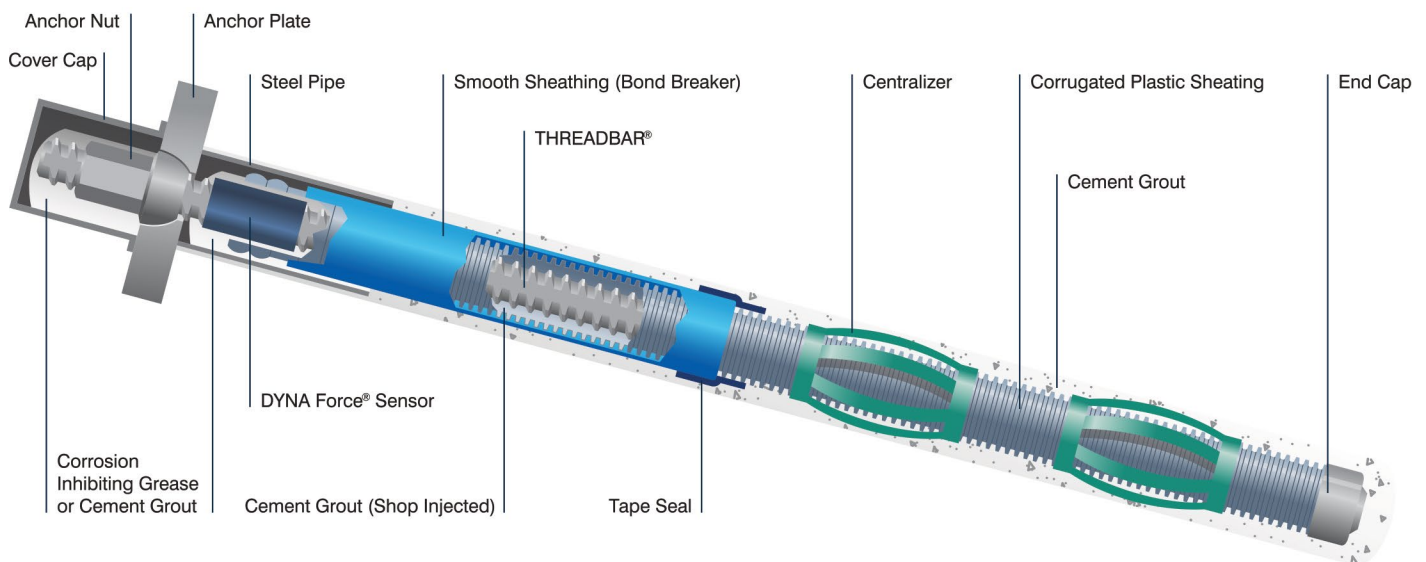

THREADBAR® ANCHOR – TEMPORARY

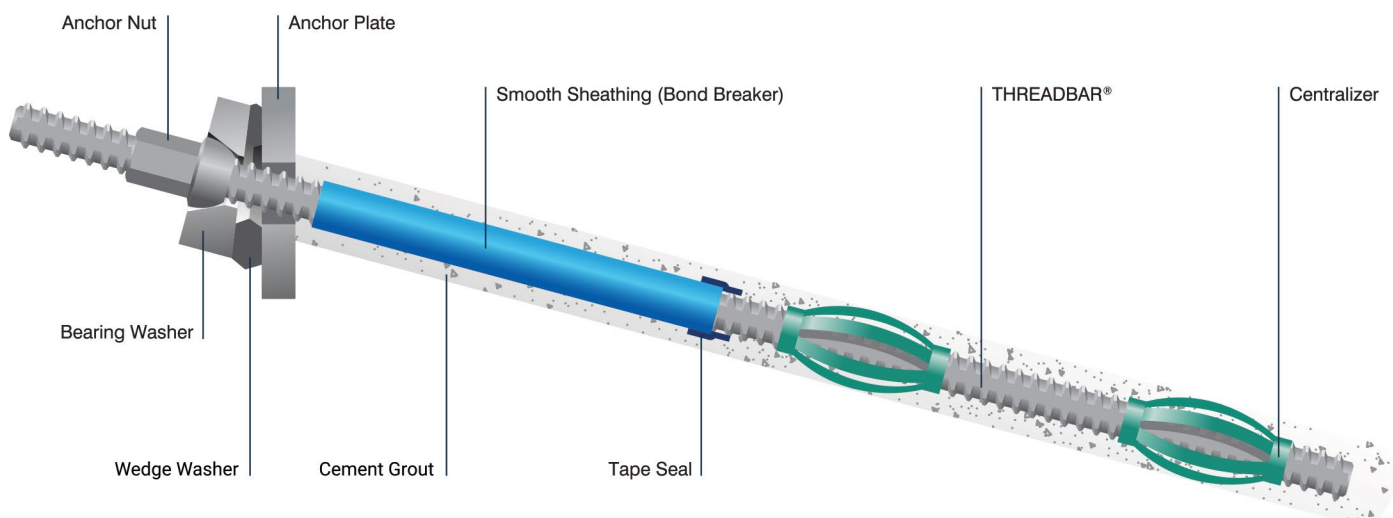

THREADBAR® ANCHORS

GRADE 150 THREADBAR® - PRESTRESSING STEEL PER ASTM A722

THREADBAR® Designation		Maximum THREADBAR® Diameter		Minimum Ultimate Tensile Strength (f _u)		Nominal Cross Section Area (A _s)		Minimum Ultimate Tensile Load (f _u x A _s)		Nominal Weight	
in	mm	in	mm	ksi	MPa	in ²	mm ²	kips	kN	lbs/ft	kg/m
1	26	1.20	30	150	1,034	0.85	548	127.5	567	3.01	4.48
1 ¼	32	1.445	37	150	1,034	1.25	806	187.5	834	4.39	6.53
1 ½	36	1.630	41	150	1,034	1.58	1,019	237.0	1,054	5.56	8.27
1 ¾	46	2.08	53	150	1,034	2.58	1,665	387.0	1,721	9.37	13.94
2 ¼ ¹⁾	57	2.482	63	150	1,034	4.08	2,632	612.0	2,722	14.55	21.65
2 ½	65	2.790	71	150	1,034	5.16	3,329	774.0	3,443	18.20	27.08
3	75	3.146	80	150	1,034	6.85	4,419	1,028	4,571	24.09	35.85

Note: Maximum allowable temporary test tension is 80% of minimum ultimate tensile load. Mill lengths are 60 ft for 1", 1 ¼", 1 ½" and 1 ¾" and 45 ft for 2 ¼", 2 ½" and 3" bars.

¹⁾ Threadbar size not listed in the ASTM A 722 but its strength is in conformance with this standard.

WARNING: DO NOT WELD on or near A722 prestressing bars or their anchorages.

THREADBAR® ANCHOR - PARTIALLY REMOVABLE

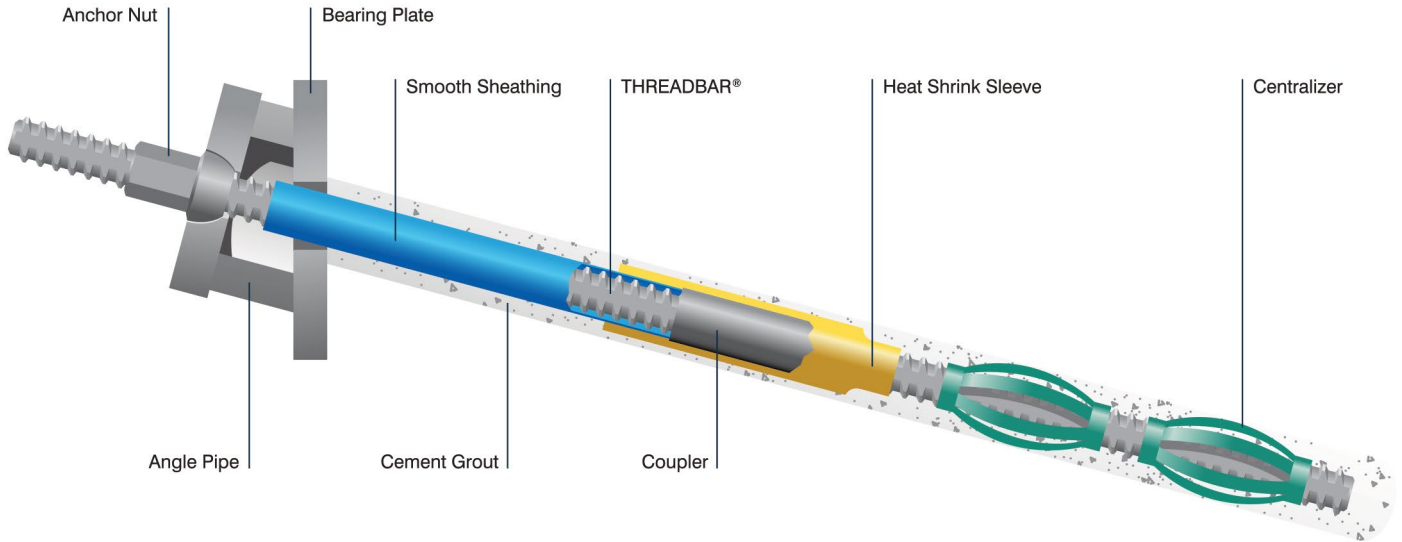

THREADBAR® ANCHOR - FULLY REMOVABLE

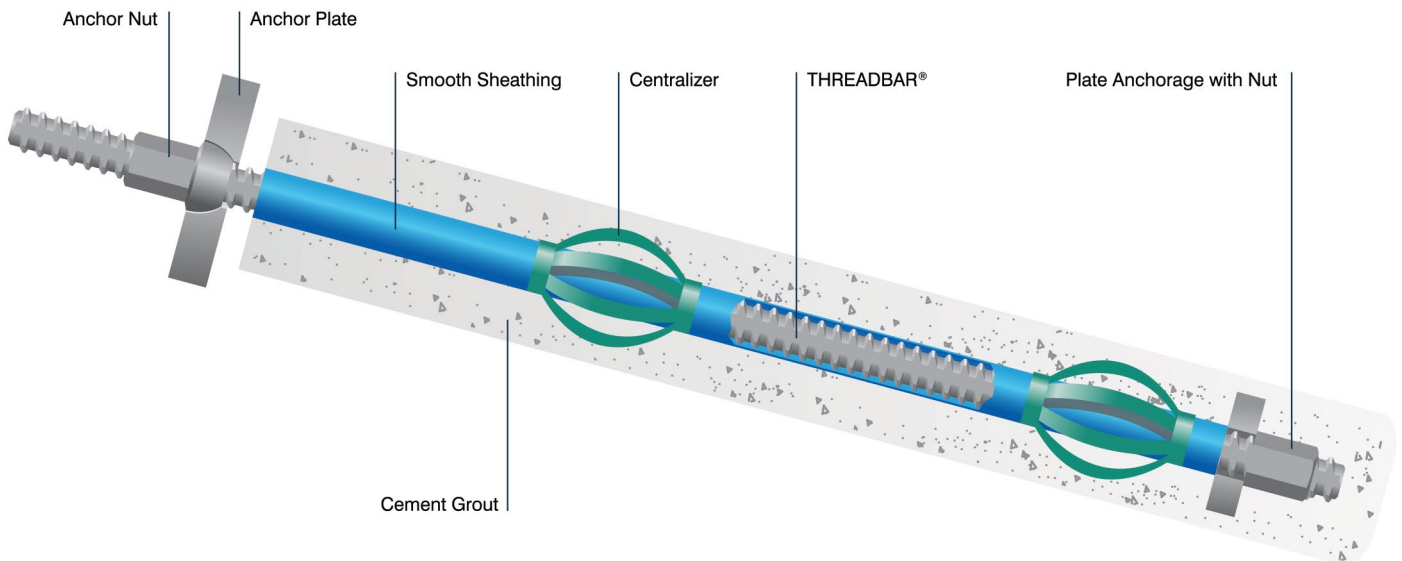

STRAND ANCHORS

PERMANENT (DCP) ANCHOR – KEY FEATURES

- Long-lasting system for permanent use
- Variable anchor head and angle compensation designs
- Double Corrosion Protection (DCP) is achieved by protecting the strands with barrier against corrosion. It consists of a corrugated sheathing, a pipe welded to the bearing plate and a cover cap along with encasement in cement grout.

FIELDS OF APPLICATION

- Retaining walls
- Rock and slope stabilization
- Tiedown anchors
- Excavations

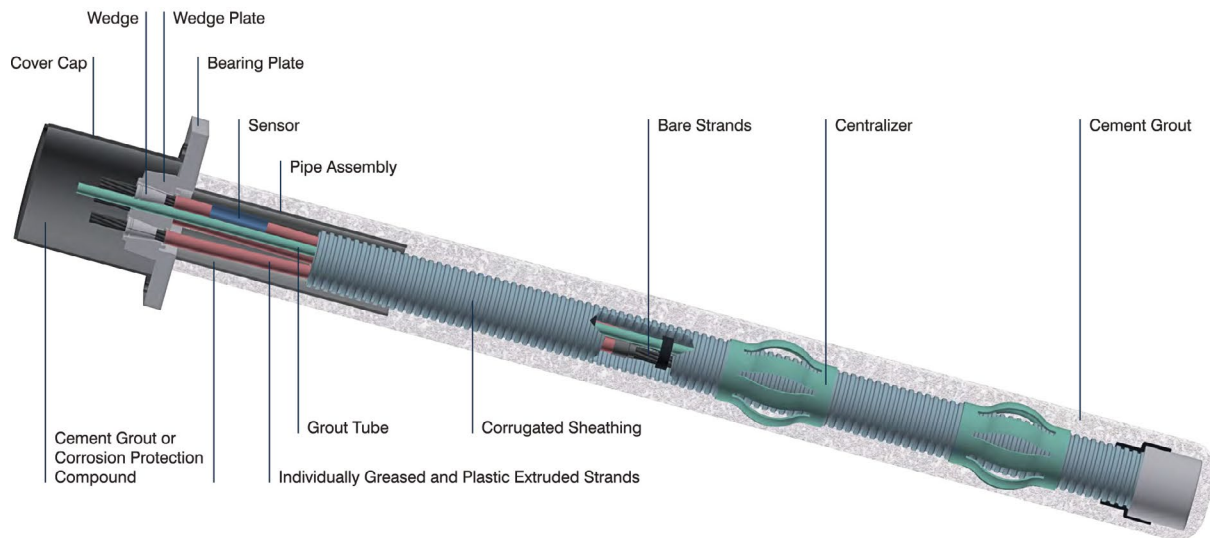

TEMPORARY ANCHOR – KEY FEATURES

- Temporary system for a service life of up to two years
- Variable anchor head and angle compensation designs

FIELDS OF APPLICATION

- Excavations
- Temporary structures

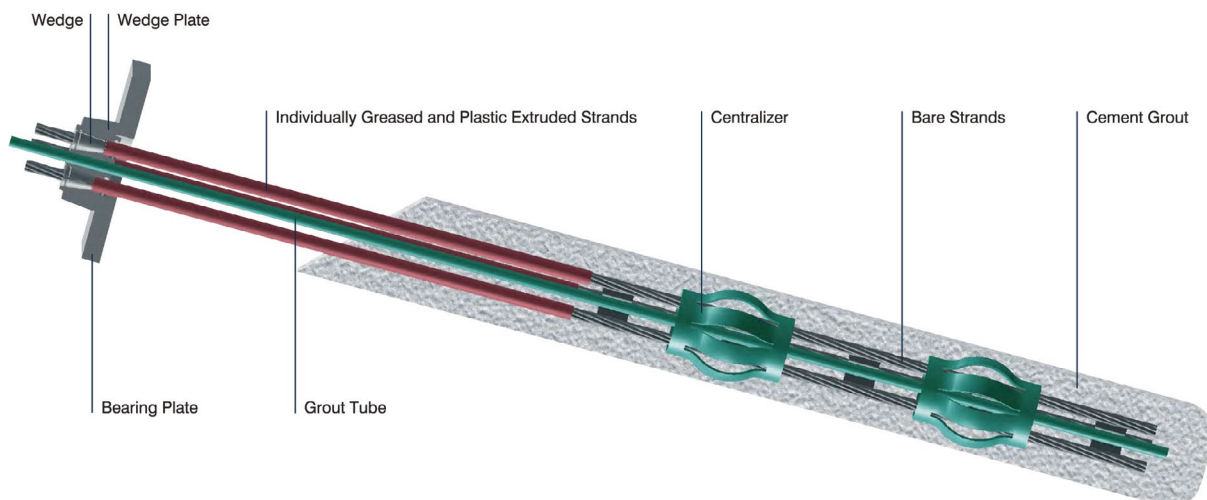

STRAND ANCHORS

STRAND ANCHORS PROPERTIES

Strand Anchors utilize 0.6" dia. 7-wire, low relaxation 270 ksi Strand conforming to ASTM A416 (bare strand) or ASTM A882 (epoxy coated strand).

Number of Strands	Nominal Cross Section Area (A_{ps})		Ultimate Strength ($F_{pu} \times A_{ps}$)		Prestressing Force						Nominal Weight (Bare Steel only)	
					$0.80 F_{pu} \times A_{ps}$		$0.70 F_{pu} \times A_{ps}$		$0.60 F_{pu} \times A_{ps}$			
ea	in ²	mm ²	kips	kN	kips	kN	kips	kN	kips	kN	lbs/ft	kg/m
1	0.217	140	58.6	261	46.9	208	41	182	35.2	156	0.74	1.09
2	0.434	280	117.2	521	93.7	417	82	365	70.3	313	1.48	1.64
3	0.651	420	175.8	782	140.6	625	123	547	105.5	469	2.22	3.27
4	0.868	560	234.4	1,043	187.5	834	164.1	730	140.6	626	2.96	4.46
5	1.085	700	293.0	1,303	234.4	1,043	205.1	912	175.8	782	3.70	5.51
6	1.302	840	351.6	1,564	281.3	1,251	246.1	1,095	210.9	938	4.44	6.55
7	1.519	980	410.2	1,825	328.2	1,460	287.2	1,277	246.2	1,095	5.18	7.74
8	1.736	1,120	468.8	2,085	375.0	1,668	328.1	1,460	281.3	1,251	5.92	8.78
9	1.953	1,260	527.4	2,346	421.9	1,877	369.2	1,642	316.4	1,408	6.66	9.97
12	2.604	1,680	703.2	3,128	562.6	2,503	492.3	2,190	422.0	1,877	8.88	13.24
15	3.255	2,100	879.0	3,910	703.2	3,128	615.3	2,737	527.4	2,346	11.10	16.52
19	4.123	2,660	1,113.4	4,953	890.7	3,962	779.4	3,467	668.0	2,972	14.06	20.98
27	5.859	3,780	1,582.2	7,038	1,265.8	5,631	1,107.6	4,927	949.4	4,223	19.98	29.76
37	8.029	5,180	2,168.2	9,645	1,734.6	7,716	1,517.8	6,751	1,301.0	5,787	27.38	40.78
48	10.416	6,720	2,812.8	12,512	2,250.2	10,009	1,968.9	8,758	1,687.7	7,507	35.52	52.83
54	11.718	7,560	3,164.4	14,076	2,531.5	11,261	2,215.1	9,853	1,898.6	8,446	39.96	59.38
61	13.237	8,540	3,574.6	15,901	2,859.7	12,721	2,502.2	11,131	2,144.8	9,540	45.14	67.12

A_{ps} = Area Prestressing Steel.

F_{pu} = Minimum Ultimate Strength.

Please consult your local sales office for systems exceeding 61 strands.

DCP STRAND ANCHOR AND WEDGE PLATE DIMENSIONS

Strand Range Inside Sheathing ¹⁾	HDPE Corrugated			Trumpet Pipe		Wedge Plate Dimensions			
	Nom. Size in	O.D. in	O.D. mm	O.D. in	O.D. mm	ØG in	ØG mm	H in	H mm
1-3	2	2.44	62	4.5	114	4.69	119	1.8	46
4	2.5	2.92	74	4.5	114	4.69	119	1.8	46
5-6	2.5	2.92	74	4.5	114	5.61	142	2.2	56
7	3	3.60	91	4.5	114	5.61	142	2.2	56
8-9	3	3.60	91	5.63	143	5.75	146	1.69	43
10-12	4	4.60	117	5.63	143	6.75	171	1.95	50
13-15	4	4.60	117	6.63	168	7.09	180	1.97	50
16-17	4	4.60	117	8.63	219	7.87	200	2.17	55
18-19	5	5.85	149	8.63	219	7.87	200	2.17	55
20-24	5	5.85	149	8.63	219	9.45	240	2.95	75
25-27	6	6.8	173	8.63	219	9.45	240	2.95	75

¹⁾ Based on the use of a single 0.5" ID x 0.75" OD internal grout tube. Bearing plate sizes subject to project specific requirements.

Strand anchors larger than 27 strand systems also available.

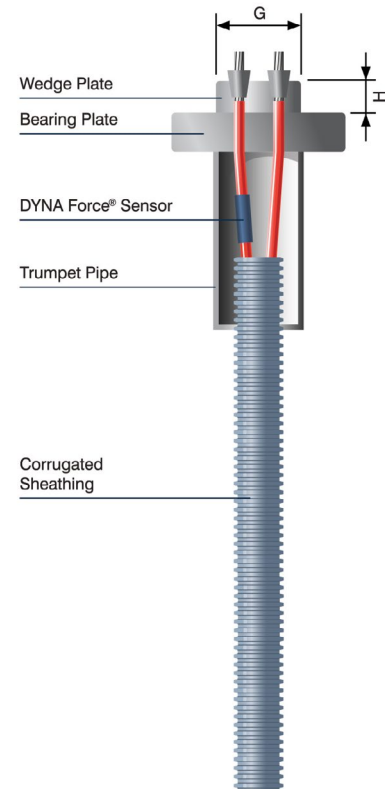

MICROPILES

BASIC CONCEPT

A drilled and grouted micropile, with a diameter of less than 12 inches. It is centrally reinforced with either one or a group of **THREADBARS®**. The deformations on the bar transfer the load into the surrounding grout body and friction transfers the load from the grout into the ground.

KEY FEATURES

- Compact lightweight drilling equipment allows for pile installation even in areas with low headroom
- Small economic drill hole diameters
- Drill holes can be placed closely to existing walls or structures
- Vibration free drilling prevents damage to adjacent structures
- Double Corrosion Protected (DCP) bars may be utilized for piles in aggressive ground
- Multiple bars can be installed into a single borehole
- Short bar sections with couplers can be utilized in low headroom locations
- Continuous, coarse thread allows for rough site handling and for easy on site length adjustments since cutting or coupling of the rod is possible along its entire length

SINGLE CORROSION PROTECTION (SCP)

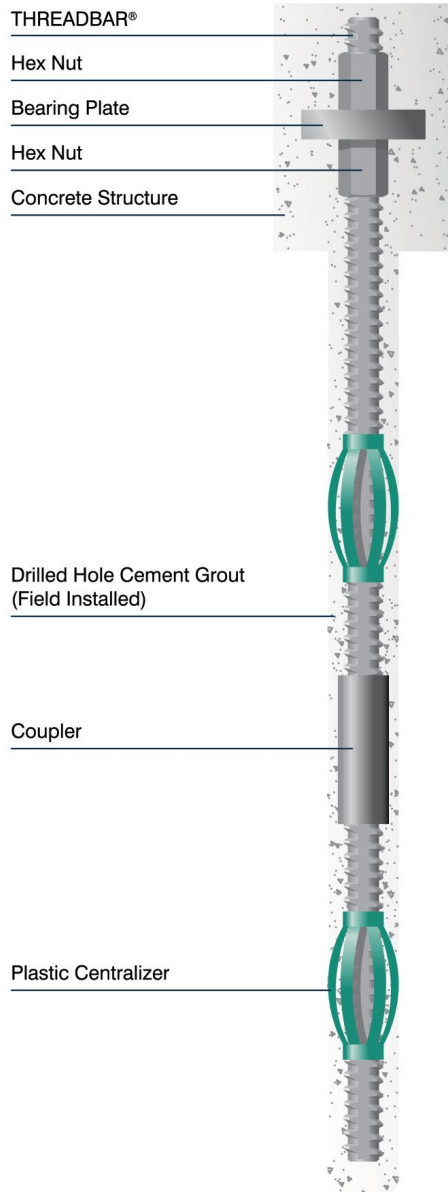

DOUBLE CORROSION PROTECTION (DCP)

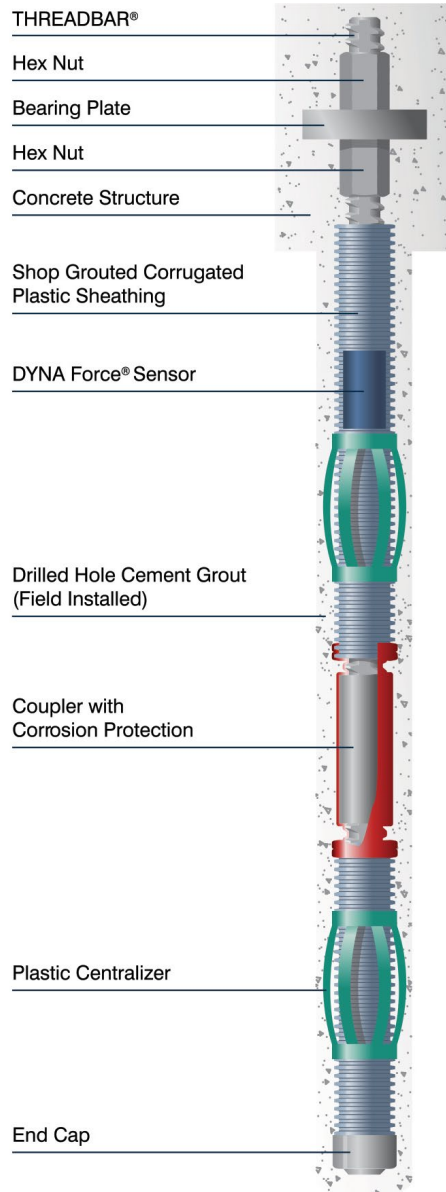

MICROPILE CASING

THREADED CASING FOR MICROPILE

Outside Diameter	Thickness	Inside Diameter	Weight	Cross Sectional Area	Total Area of Shaft	Internal Volume	External Surface Area	Moment of Inertia	Section Modulus
in mm	in mm	in mm	lbs/ft kg/m	in ² cm ²	in ² cm ²	ft ³ /ft m ³ /m	ft ² /ft m ² /m	in ⁴ cm ⁴	in ³ cm ³
5.5 139.700	0.415 10.541	4.670 118.618	22.56 33.57	6.63 42.77	23.76 153.28	0.12 0.011	1.44 0.44	21.57 897.80	7.84 128.47
7 177.800	0.408 10.363	6.184 157.073	28.75 42.79	8.45 54.51	38.48 248.29	0.21 0.019	1.83 0.56	46.07 1917.56	13.16 215.65
7 177.800	0.453 11.506	6.094 154.787	31.70 47.18	9.32 60.11	38.48 248.29	0.20 0.019	1.83 0.56	50.16 2087.80	14.33 234.83
7.625 193.675	0.430 10.922	6.765 171.831	33.07 49.21	9.72 62.71	45.66 294.60	0.25 0.023	2.00 0.61	63.12 2627.23	16.56 271.31
7.625 193.675	0.500 12.700	6.625 168.275	38.08 56.67	11.19 72.21	45.66 294.60	0.24 0.022	2.00 0.61	71.37 2970.62	18.72 306.76
8.625 219.075	0.500 12.700	7.625 193.675	43.43 64.63	12.76 82.34	58.43 376.94	0.32 0.029	2.26 0.69	105.72 4400.36	24.51 401.65
9.625 244.475	0.472 11.989	8.681 220.497	46.18 68.73	13.57 87.56	72.76 469.42	0.41 0.038	2.52 0.77	142.51 5931.67	29.61 485.22
9.625 244.475	0.545 13.843	8.535 216.789	52.90 78.73	15.55 100.30	72.76 469.42	0.40 0.037	2.52 0.77	160.80 6692.95	33.41 547.49
9.875 250.83	0.625 15.875	8.625 219.075	61.80 91.97	18.16 117.16	31.02 200.13	0.41 0.038	2.59 0.79	195.14 8122.23	39.52 647.62
10.75 273.050	0.500 12.700	9.750 247.650	54.79 81.54	16.10 103.87	90.76 585.56	0.52 0.048	2.81 0.86	211.95 8821.95	39.43 646.14
10.75 273.050	0.545 13.843	9.660 245.364	59.46 88.49	17.47 112.73	90.76 585.56	0.51 0.047	2.81 0.86	228.10 9494.16	42.44 695.46
10.75 273.050	0.595 15.113	9.560 242.824	64.59 96.12	18.98 122.47	90.76 585.56	0.50 0.046	2.81 0.86	245.53 10219.65	45.68 748.56
11.875 301.624	0.582 14.783	10.711 272.059	70.26 104.56	20.65 133.21	110.75 714.53	0.63 0.058	3.11 0.95	330.04 13737.19	55.59 910.95
12.75 323.849	0.500 12.700	11.750 298.449	65.48 97.45	19.24 124.14	127.68 823.71	0.75 0.070	3.34 1.02	361.54 15048.31	56.71 929.31
13.375 339.724	0.480 12.192	12.415 315.340	66.17 98.47	19.45 125.45	140.50 906.45	0.84 0.078	3.50 1.07	404.73 16846.00	60.52 991.74
13.375 339.724	0.514 13.056	12.347 313.613	70.67 105.17	20.77 133.98	140.50 906.45	0.83 0.077	3.50 1.07	430.07 17900.72	64.31 1053.85

Dimensions based on theoretical.

Contact Chris Gabuzda for additional diameters, lengths, and starter details.

cgabuzda@jdfields.com

Cell: (412) 414 0044

THREADBAR® PROPERTIES

GRADE 75, 80 THREADBAR® – REINFORCING STEEL PER ASTM A615

THREADBAR® Designation	Maximum THREADBAR® Diameter			Minimum Yield Stress (f _y)		Nominal Cross Section Area (A _s)		Minimum Yield Load (f _y x A _s)		Nominal Weight	
	mm	in	mm	ksi	MPa	in ²	mm ²	kips	kN	lbs/ft	kg/m
#6	19	0.86	22	75	517	0.44	284	33.0	147	1.50	2.23
#7	22	0.99	25	75	517	0.60	387	45.0	200	2.04	3.04
#8	25	1.12	28	75	517	0.79	510	59.3	264	2.67	3.97
#9	29	1.26	32	75	517	1.00	645	75.0	334	3.40	5.06
#10	32	1.43	36	75	517	1.27	819	95.3	424	4.30	6.40
#11	36	1.61	41	75	517	1.56	1,006	117.0	520	5.31	7.90
#14	43	1.86	47	80	552	2.25	1,452	180.0	801	7.65	11.38
#18	57	2.50	64	80	552	4.00	2,581	320.0	1,423	13.60	20.24
#20	63	2.72	69	80	552	4.91	3,168	393.0	1,748	16.70	24.85
#24 ¹⁾	75	3.18	81	75	517	7.06	4,555	529.5	2,355	24.09	35.85
#28 ¹⁾	90	3.68	94	75	517	9.62	6,206	721.5	3,209	32.79	48.80

Note: Maximum allowable temporary tension is 90% of minimum yield load. Mill length is 60 ft (#6 through #20) and 53 ft for #24 and #28.

¹⁾ Threadbar sizes not listed by ASTM A 615 but yield strength is in conformance with A615 standard.

GRADE 100 THREADBAR® – REINFORCING STEEL PER ASTM A615

THREADBAR® Designation	Maximum THREADBAR® Diameter			Minimum Yield Stress (f _y)		Nominal Cross Section Area (A _s)		Minimum Yield Load (f _y x A _s)		Nominal Weight	
	mm	in	mm	ksi	MPa	in ²	mm ²	kips	kN	lbs/ft	kg/m
#6	19	0.86	22	100	689	0.44	284	44.0	196	1.50	2.23
#7	22	0.99	25	100	689	0.60	387	60.0	267	2.04	3.04
#8	25	1.12	28	100	689	0.79	510	79.0	351	2.67	3.97
#9	29	1.26	32	100	689	1.00	645	100.0	445	3.40	5.06
#10	32	1.43	36	100	689	1.27	819	127.0	565	4.30	6.40
#11	36	1.61	41	100	689	1.56	1,006	156.0	694	5.31	7.90
#14	43	1.86	47	100	689	2.25	1,452	225.0	1,001	7.65	11.38
#18	57	2.50	64	100	689	4.00	2,581	400.0	1,779	13.60	20.24
#20	63	2.72	69	100	689	4.91	3,168	491.0	2,184	16.70	24.85

Note: Maximum allowable temporary tension is 90% of minimum yield load. Mill length is 60 ft.

GRADE 150 THREADBAR® – PRESTRESSING STEEL PER ASTM A722

THREADBAR® Designation	Maximum THREADBAR® Diameter		Minimum Ultimate Tensile Strength (f _u)		Nominal Cross Section Area (A _s)		Minimum Ultimate Tensile Load (f _u x A _s)		Nominal Weight			
	in	mm	in	mm	ksi	MPa	in ²	mm ²	kips	kN	lbs/ft	kg/m
1		26		30	150	1,034	0.85	548	127.5	567	3.01	4.48
1 ¼		32		37	150	1,034	1.25	806	187.5	834	4.39	6.53
1 ½		36		41	150	1,034	1.58	1,019	237.0	1,054	5.56	8.27
1 ¾		46		53	150	1,034	2.58	1,665	387.0	1,721	9.37	13.94
2 ¼ ¹⁾		57		63	150	1,034	4.08	2,632	612.0	2,722	14.55	21.65
2 ½		65		71	150	1,034	5.16	3,329	774.0	3,443	18.20	27.08
3		75		80	150	1,034	6.85	4,419	1,028	4,571	24.09	35.85

Note: Maximum allowable temporary test tension is 80% of minimum ultimate tensile load. Mill lengths are 60 ft for 1", 1 ¼", 1 ½" and 1 ¾" and 45 ft for 2 ¼", 2 ½" and 3" bars.

¹⁾ Threadbar size not listed in the ASTM A 722 but its strength is in conformance with this standard.

WARNING: DO NOT WELD on or near A722 prestressing bars or their anchorages.

DRILL HOLLOW BAR SYSTEM

BASIC CONCEPT

The Drill Hollow Bar System consists of fully threaded steel bar sections, couplers, nuts and drill bits.

It can be drilled and grouted into loose or collapsible soil without a casing.

The bar sections feature a hollow center that allows for a simultaneous drilling and grouting operation.

The Drill Hollow Bar serves as a drill rod. It is fitted with a lost drill bit at the front that can be adapted to different ground conditions. After each single bar section of 1 to 6 m, the subsequent bar is coupled to the previously installed section.

During drilling, cement grout is injected into the hollow core of the bar using an injection adapter that is mounted on the drill rig. The cement grout exits at the bottom end through openings in the drill bit. The injected grout initially serves

as slurry to stabilize the borehole and ensures the efficient flushing of the drill spoils. Once the grout reached strength it bonds the bar to the ground.

Once the required installation depth has been reached, the hollow bar serves as a steel tendon and can carry

out its function as a soil nail, rock bolt or pile upon the grout reaching its required strength.

The comprehensive Drill Hollow Bar System product range offers tendons with ultimate loads from 45 kips to 832 kips including all system components such as drill bits, couplers, spacers and anchor heads.

Additional installation tools such as injection adapters can be produced customized or adjusted to job site requirements on short notice.

DRILL HOLLOW BAR – SOIL NAIL

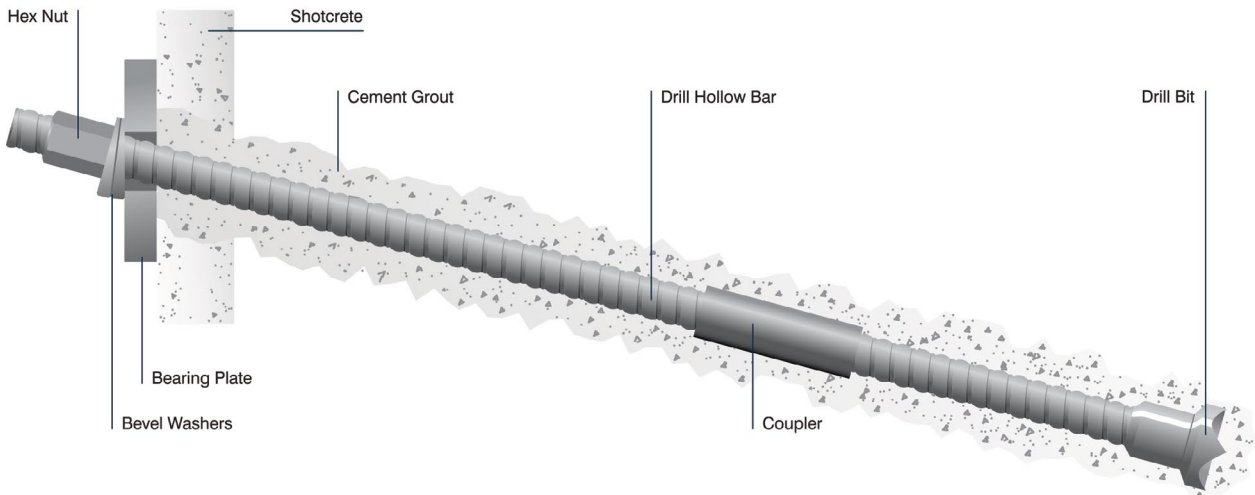

KEY FEATURES

- The tendon simultaneously serves as a drill rod
- Extremely fast installation because borehole drilling is made redundant by simultaneous drilling and grouting
- System can be installed in confined spaces utilizing simple and compact drilling equipment
- Variable anchorage and angle compensation designs
- Irregular grout body enhances capacity
- Drill bits are available for various ground conditions
- Can be used as a soil nail, rock bolt or a pile

FIELDS OF APPLICATION

- Slope, embankment and rock stabilization
- Shoring and excavations
- Fixation of rock fall mesh
- Avalanche barriers
- Foundations



Various Style Drill Bits for DYWI® Drill

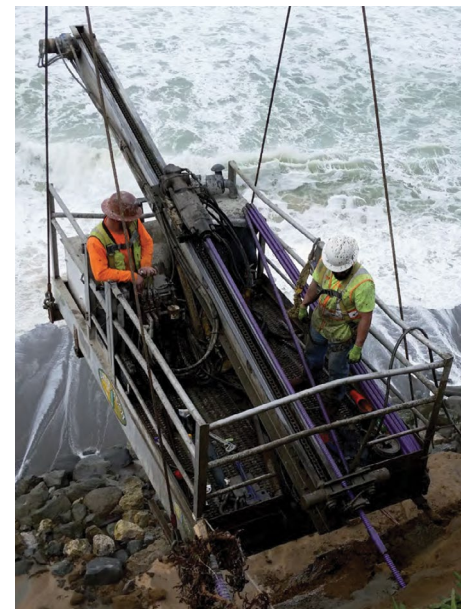

DRILL HOLLOW BAR MICROPILE

DRILL HOLLOW BAR – MICROPILE

Drill Hollow Bar

Hex Nut

Bearing Plate

Hex Nut

Concrete Structure

Drilled Hole
Cement Grout
(Injected during Drilling
Process)

Coupler

Drill Bit

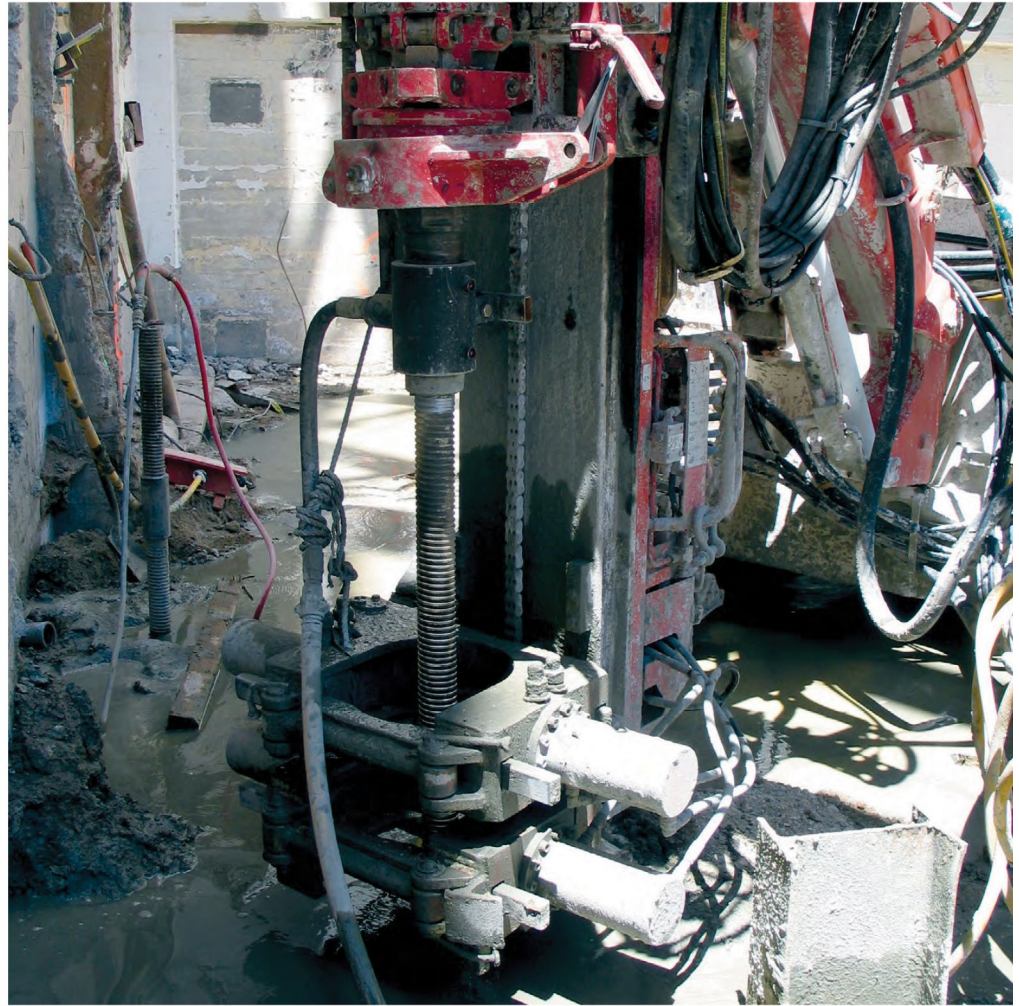

Simultaneous Drilling and Grouting

DRILL HOLLOW BAR PROPERTIES

Bar Des.	Nominal Outer Diameter		Average Yield Strength (f_y)		Average Ultimate Tensile Strength (f_u)		Average Cross Section Area (A_s)		Yield Load ($f_y \times A_s$)		Ultimate Load ($f_u \times A_s$)		Nominal Weight	
	in	mm	ksi	Mpa	ksi	MPa	in ²	mm ²	kips	kN	kips	kN	lbs/ft	kg/m
R25N	1.00	25	90	620	120	830	0.37	240	34	150	45	200	1.28	1.90
R32N	1.26	32	94	650	116	800	0.54	350	52	230	63	280	1.81	2.70
R32S	1.26	32	94	650	120	830	0.67	430	63	280	81	360	2.28	3.40
R38N	1.50	38	97	670	122	840	0.91	590	90	400	112	500	3.16	4.70
R51L	2.00	51	87	600	107	740	1.15	740	101	450	124	550	3.97	5.90
T40N	1.57	40	99	680	123	850	1.19	770	118	525	148	660	4.03	6.00
R51N	2.00	51	97	670	123	850	1.46	940	142	630	180	800	4.97	7.40
T76N	3.00	76	83	570	110	760	3.22	2,080	270	1,200	360	1,600	10.95	16.30
T76S	3.00	76	87	600	112	770	3.81	2,460	337	1,500	427	1,900	12.97	19.30
T103N	4.00	103	81	560	103	710	4.96	3,200	405	1,800	517	2,300	16.80	25.00
T103S	4.00	103	74	510	103	710	8.06	5,200	600	2,670	832	3,700	26.88	40.00

Note: Maximum allowable temporary tension is the yield load. Cross section area is based on average internal diameter of the bar.
The ultimate tensile and yield strength are calculated average values.
Standard length = 9'-10" (3 m). Other lengths available on special order.