

PILING ACCESSORIES AND DETAILS

SHEET PILE DRIVE POINTS

We make a "universal" tip to fit all piles, as well as a wide selection of tips made to fit each of the most popular sheet piles used.

WELD PROCEDURE

These points should be welded with a 5/16" fillet along the entire length of the top flange on both sides using 70xx series rod.

FEATURES

- Universal Straight Bar
- Other types can be made



Sheet pile shoes are only available for PZC 13 & 18. All other sizes require bar stock.

HANDLING HOLES

Handling holes are standard for all sheet pile sections and are located in the centerline of each section.

Y = 6" (152.4 mm)

Ø = 2.5" - 2.625" (63.5 mm - 66.7 mm)

Note: The Y location can be adjusted if needed upon request.

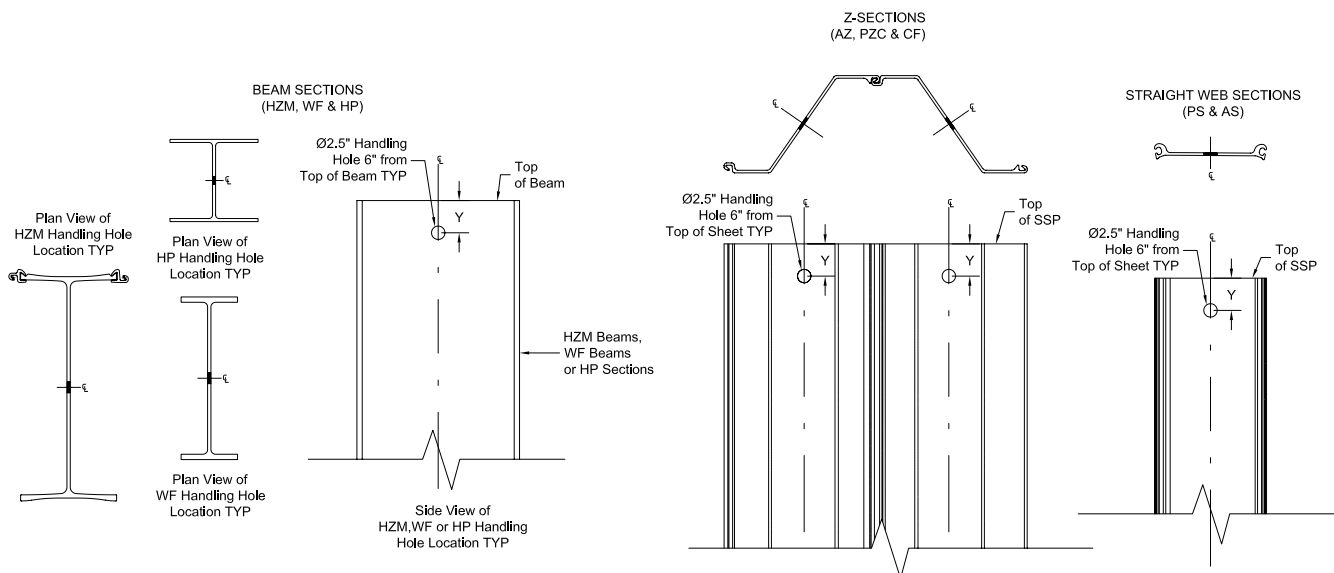

H-PILE ACCESSORIES

H-PILE POINTS

H-Pile points are made of high strength, low alloy cast steel. Cast steel is a superior material choice because it's isotropic – its properties are uniform in all directions. Cast steel points absorb impact and transfer it uniformly to the end of the pile.

Tips are pre-beveled, eliminating pile end preparation. The weld prep is already built into the point; our castings have a 45 degree weld chamfer so there is no need to chamfer piles.

WELD PROCEDURE

1. To ensure proper seating of the tip, remove all flash from end of pile and insert tip.
2. Using a 70xx series rod, make a single pass weld across each flange on the outside only.
3. Do not weld web or inside of flanges.
4. For heavier sections, you may want to use multiple welding passes.

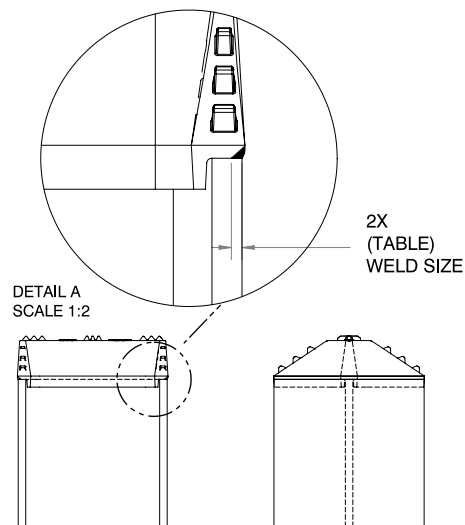
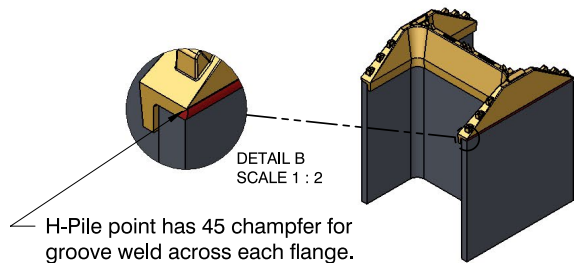

H-PILE SPLICER

H-Pile splicers save time during driving of long piles by eliminating the need for a full penetration weld. Made in ASTM A572 GR.50 or higher strength if requested.

WELD PROCEDURE

1. Cut 1.0" wide x 1.0" long notch in center of web of one pile.
2. Chamfer outside edges of flanges on ends of one or both piles to be spliced. Make chamfer to about 1/2 material thickness.
3. Insert splicer on first pile making sure bolt is completely inside notch.
4. Install the next section of pile and tighten bolt.
5. Using a 70xx series rod, weld the flanges of splicer to the flanges of the pile with (TABLE)" by 3" vertical fillets.
6. Weld the outside flanges of the piles to complete.

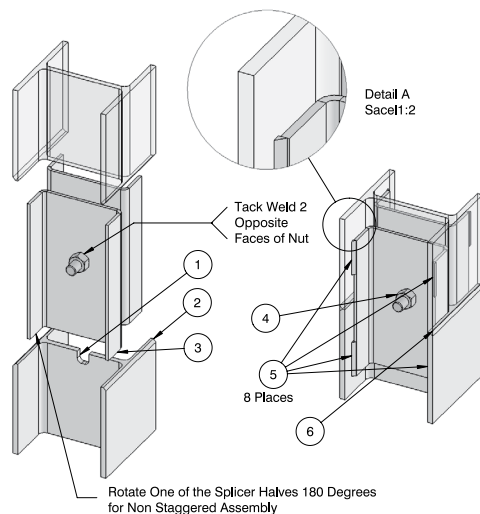

H-PILE ACCESSORIES

H-PILE POINT

DIMENSIONS

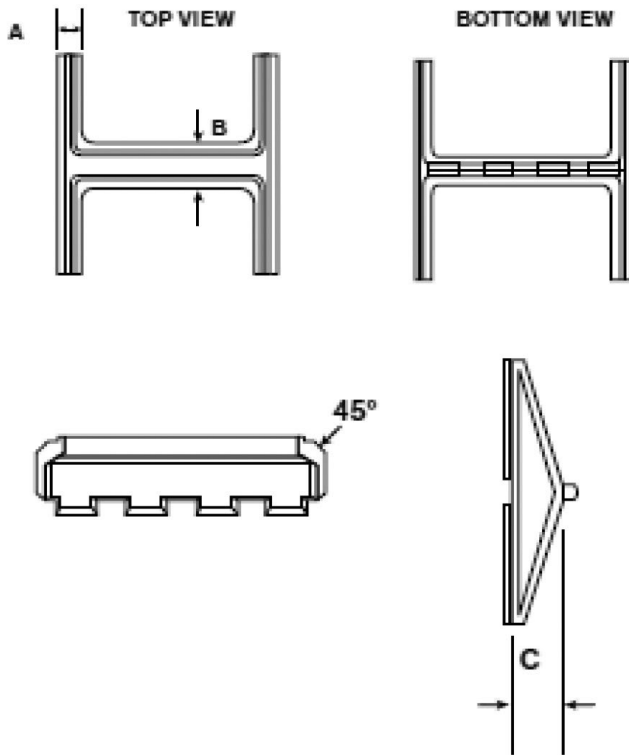

ASTM A148 90/60 - Heat Treated			
	10"	12"	14"
A	1"	1-1/4"	1-1/4"
B	1-1/4"	1-7/16"	1-3/4"
C	2-9/16"	2-5/8"	2-15/16"
WT	14	23	30

Normal Foundry Tolerances Apply

INSTALLATION INSTRUCTIONS

1. Fit point onto the end of the square cut pile end.
2. Weld point to the pile in either flat or vertical position using E70XX electrodes or equivalent filler material.
3. Weld across full width of flange following chart below for minimum size weld.

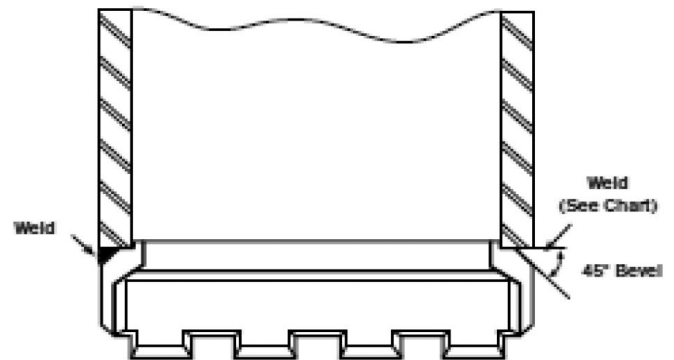

Pile Size	Flange Thickness	Minimum Size Groove Weld
HP 14 x 117	.805	7/16
HP 14 x 102	.705	3/8
HP 14 x 89	.615	3/8
HP 14 x 73	.505	5/16
HP 12 x 84	.685	3/8
HP 12 x 74	.610	3/8
HP 12 x 63	.515	5/16
HP 12 x 53	.435	5/16
HP 10 x 57	.565	5/16
HP 10 x 42	.420	5/16

INSIDE FLANGE CONICAL POINTS

Conical Points are the preferred end closure for pipe piles. The conical shape pushes the earth aside and preserves friction. The snub nose conical is an economical design which provides end protection in most soil conditions.

SIZE:

The snub nose conical point is available for 8-5/8", 10-3/4", 12", 12-3/4", 14", 16", 18", 20", and 24" O.D. pipe.

BENEFITS:

60 degree Conical Points with heavy internal ribs aid in penetration in most soils. On boulders or uneven rock, the point helps to distribute the load around the periphery of the pipe rather than concentration it on a quadrant - as occurs with plate closure.

STEEL GRADE:

High Strength Heat-Treated Cast Steel Grade ASTM A148 80/50 - other grades also available.

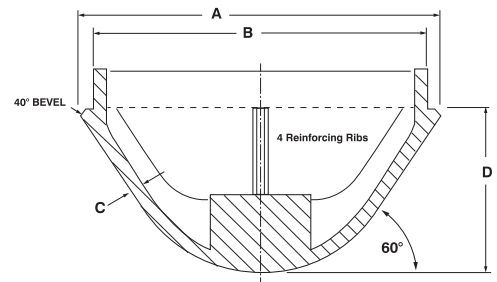

INSIDE-FIT CONICAL PIPE POINTS

Inside-fit conical points are manufactured with 60 degree slope for optimum ease in penetration and even distribution of load. The conical points are slip fit and can accommodate schedule 80 and thicker wall pipe. There is an option of a blunt nose if desired.

Our conical points are easy to install with a slip-on fit. The design places the cross-sectional area directly below the wall of the pipe for maximum support during penetration. They are a more heavy-duty construction than other brands.

The inside-fit conical point has a weld prep built into the shoe. These tips are designed with a weld chamfer built into the casting. Slip shoe inside pipe and using a 70xx series rod weld a 5/16" or larger weld all around.

WELD PROCEDURE

Welding for most sizes requires a simple 5/16" fillet weld using 70xx series rod all around the top of the flange.

Type Inside-Fit

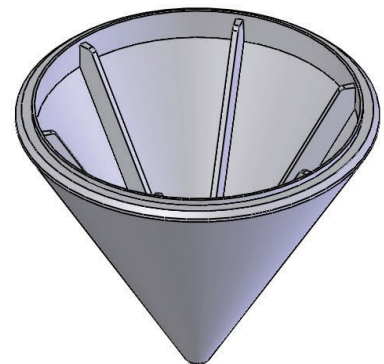

Conical Point and Pipe Cross-Section View

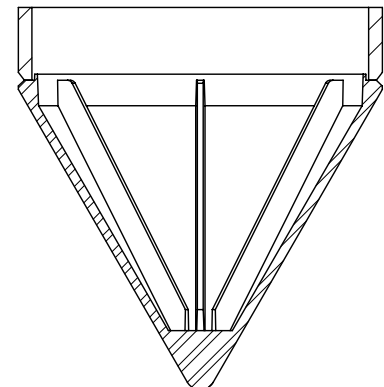

CAST STEEL PIPE SPLICERS

Cast steel splicers have the advantage of uniform sizing — there is no risk of improper fit, compared to fabricated splicers that are individually made. JDF Construction Products casts splicers in ASTM A 27, Grade 65/35, with ASTM A 148 grade 90-60 on request.

WELD PROCEDURE

Pipe splicers are drive fit. Under proper conditions, the drive fit is water tight. If welding is desired, a simple 5/16" fillet using 70xx series rod at the top and bottom is all that is required.

FEATURES

- Compression Fit
- Slip Fit

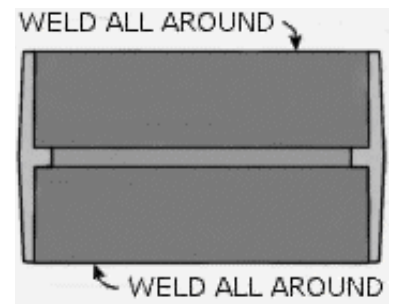

OPEN ENDED INSIDE-FIT CUTTING SHOES

Both of our cutting shoes are easy to install with a slip-on fit. The design places the cross-sectional area directly below the wall of the pipe for maximum support during penetration. They are a more heavy-duty construction than other brands. The inside-fit cutting shoe has a weld prep built into the shoe.

WELD PROCEDURE

These tips are designed with a weld chamfer built into the casting. Slip shoe inside pipe and using a 70xx series rod weld a 5/16" weld all around.

FEATURES

- Fits All Standard Pipe Sizes
- All Steel Alloy Grades

Inside-Fit

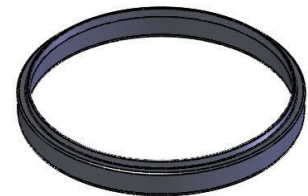

OPEN ENDED OUTSIDE-FIT CUTTING SHOES

Like our inside-fit shoe, this shoe has a slip-on fit, and the cross-sectional area lies below the wall of the pipe. The outside-fit cutting shoe has a natural fillet on top for easy welding.

WELD PROCEDURE

These slip fit shoes are easily attached with a 5/16" fillet weld at the top of the flange. For best results, weld all around the shoe with a 70xx series rod.

FEATURES

- Fits All Standard Pipe Sizes
- All Steel Alloy Grades

Outside-Fit



WELD/CHILL RINGS

We manufacture weld rings to fit all sizes of pipe and wall thicknesses. The standard weld ring is 1/8" thick.

FEATURES

- Spherical Spacers
- Short or Long Pin Spacers
- Stainless and Carbon Steel

The inside diameter of a specific nominal pipe size will vary due to the difference in pipe wall thickness. The JDF Construction Products split commercial ring is designed to compensate for these variations. When inserted into the pipe, the ring can be closed at the split or have a gap, depending on the inside diameter of the pipe. These rings are also designed and manufactured with an opening at the split which permits the welder to compress the ring when it is inserted into the pipe. When released inside the pipe opening, the ring will spring back and make contact throughout the inside circumference of the pipe. The usual procedure followed when using our JDF Construction Products split commercial rings is to insert the ring into one end of the pipe, and then bring the other pipe over the opposite end of the ring, forcing both ends of both pipes against whatever root opening spacers are furnished on that ring.

Type LG
Type LG Ring Spacers
are removed in the
welding process

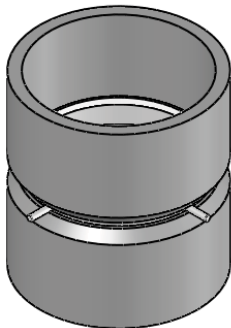

Type S
Type S Ring Spacers
may be removed or
melted into the weld

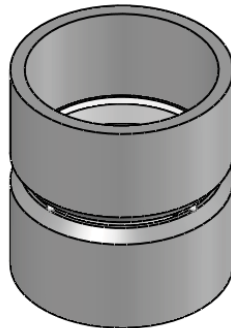

Type W
Type W Ring is
furnished without
spacers

