

S4

PERGOLA

PRO

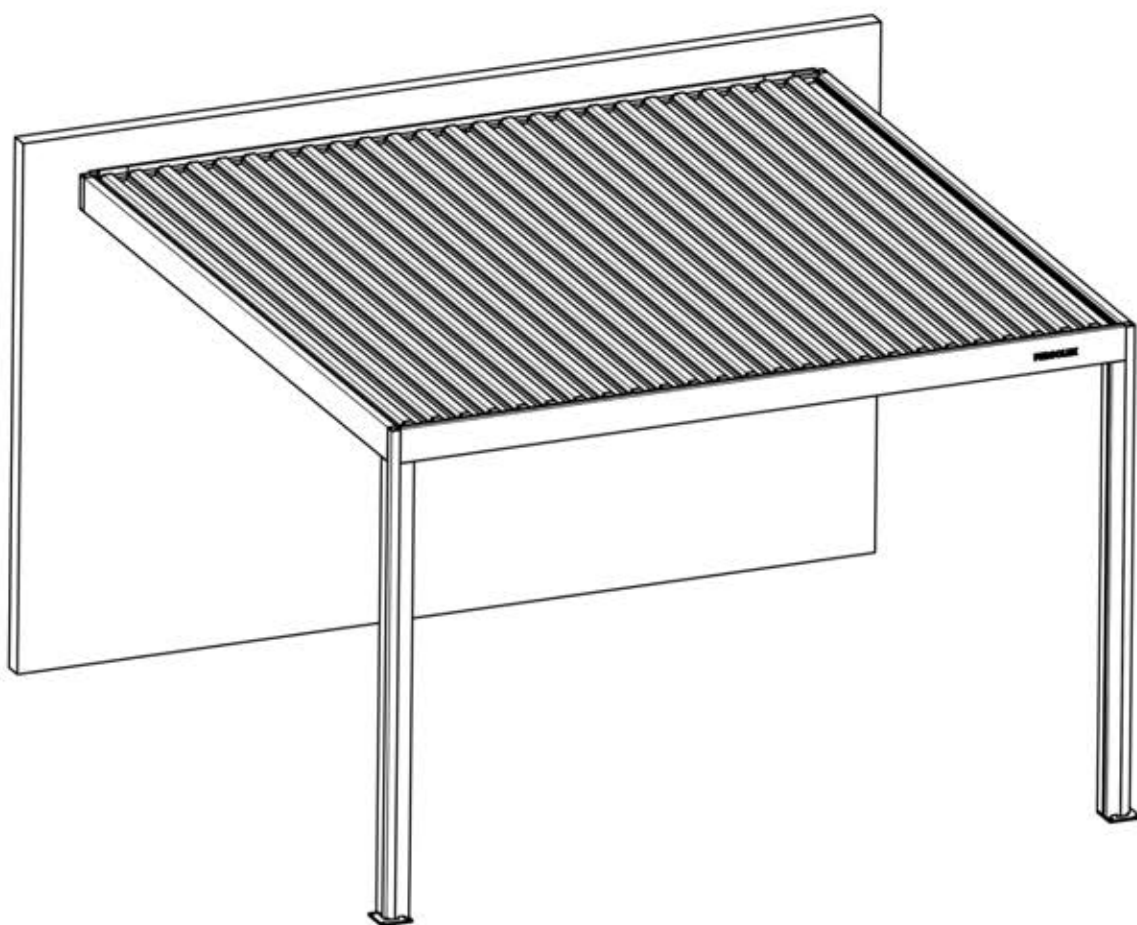

4 × 4m / 13' x 13'
ADOSSÉE

PERGOLUX



Designed and
developed
in Norway



Type Approved
Regular
Production
Surveillance

www.tuv.com
ID: 1111293124

INFORMATION

**INSTALLATION
INSTRUCTIONS:**

Ensure all parts are present and undamaged before starting the assembly.

Secure to a solid foundation with the correct fasteners for your foundation.

(If applicable) Install motors and wiring as shown. Ensure the electrical components are powered off during installation.

Use the correct lifting and installation equipment.

SAFETY WARNINGS:

Keep children and pets away during installation.

Do not operate the structure if parts are loose or improperly installed.

Ensure the structure is securely anchored to prevent accidents.

Do not insert fingers or any objects between the louvers.

MAINTENANCE:

Regularly clean the aluminum structure to maintain its appearance and prevent the accumulation of dirt.

Also, make sure to clean the gutters regularly. Inspect moving parts for wear and lubricate as necessary.

Check anchor points periodically to ensure stability.

**INSTRUCTIONS D'INSTALLATION :**

Assurez-vous que toutes les pièces sont présentes et en parfait état avant de commencer le montage.

Fixez la structure sur une fondation solide en utilisant les fixations appropriées à votre type de sol.

(Le cas échéant) Installez les moteurs et le câblage comme indiqué. Assurez-vous que les composants électriques sont hors tension pendant l'installation.

Utilisez un équipement de levage et d'installation approprié.

CONSIGNES DE SÉCURITÉ :

Tenez les enfants et les animaux domestiques à l'écart pendant l'installation.

Ne faites pas fonctionner la structure si des pièces sont desserrées ou mal installées.

Assurez-vous que la structure est solidement ancrée pour prévenir tout accident.

N'insérez pas vos doigts ou d'autres objets entre les lames.

MAINTENANCE :

Nettoyez régulièrement la structure en aluminium pour préserver son aspect et éviter l'accumulation de saleté.

Nettoyez également les gouttières régulièrement. Inspectez les pièces mobiles pour détecter toute trace d'usure et lubrifiez-les si nécessaire.

Vérifiez périodiquement les points d'ancrage pour garantir la stabilité.



Pergolux GmbH, 9 Goethestraße,
36043 Fulda,
Germany

26

DOP-PRO-FSWM-S4

EN 13561:2015

Pergolux Pergola PRO S4

**External use in buildings and other
construction works**

Resistance to wind loads: Class6(EN13561)

EXPLICATION DES SYMBOLES



Indique l'extérieur de la structure de la pergola.



Cette étape peut nécessiter un peu plus de force.



Indique l'intérieur de la structure de la pergola.



Informations importantes à respecter pendant l'installation.



Prudence lors de l'assemblage ou de la manipulation de cette pièce.



Cet article doit être acheté séparément.



Outils requis pour l'assemblage.



Appliquez du lubrifiant pour faciliter l'assemblage des vis.



La prise de terre doit être bien branchée avant de mettre l'appareil sous tension.



N'utilisez pas de marteau classique, cela pourrait causer des dommages.



Alignez les lames selon la direction du soleil pour un ombrage optimal.



Entrée AC



Répétez cette étape le nombre de fois indiqué.



Moteur



Faites pivoter / Retournez.

INFORMATION



Utilisez un mastic de haute qualité, résistant aux intempéries et à la moisissure, pour sceller les angles de la pergola et éviter les infiltrations. Optez pour des produits spécialement conçus pour une utilisation en extérieur et offrant une adhérence solide et durable.

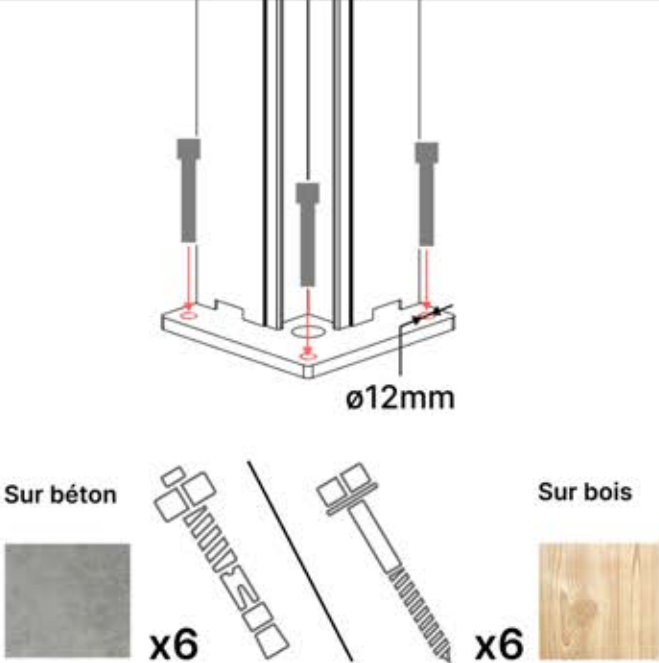

Achetez le matériel d'ancrage / les vis adaptés à votre surface d'installation.

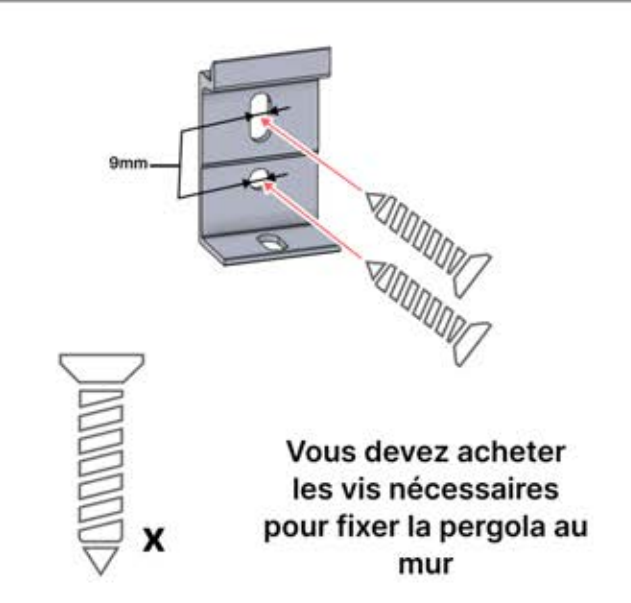

Vous devez acheter les vis nécessaires pour fixer la pergola au mur



INFORMATION

Toutes les vis PERGOLUX sont en acier inoxydable, ce qui garantit leur durabilité et leur résistance à la rouille. Pour éviter d'endommager les vis, veuillez suivre ces consignes :

- **NE PAS TROP SERRER** : Appliquez une force appropriée pour éviter de fausser le filetage.
- **CHOISIR LE BON OUTIL** : Utilisez le tournevis ou l'embout adéquat pour éviter d'endommager la tête de vis.
- **ASSURER UNE UTILISATION CORRECTE** : Avec une installation conforme, les vis conserveront leur intégrité et leur fonctionnalité dans le temps.
- **UTILISER UN LUBRIFIANT** : Appliquez du lubrifiant pour faciliter l'assemblage des vis.



OUTILS

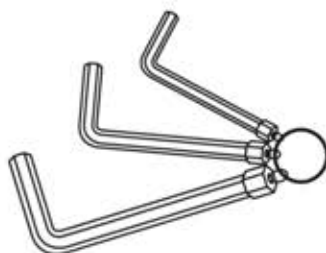
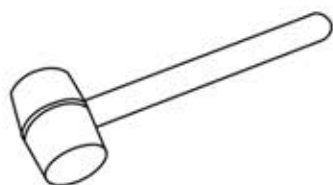

3mm, 4mm, 5mm

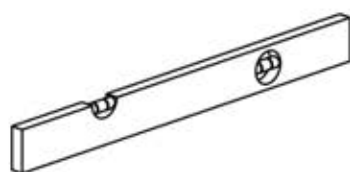
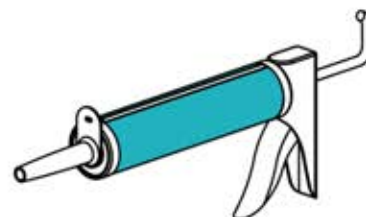
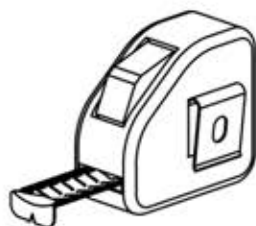

TX15, TX20, TX25, TX30





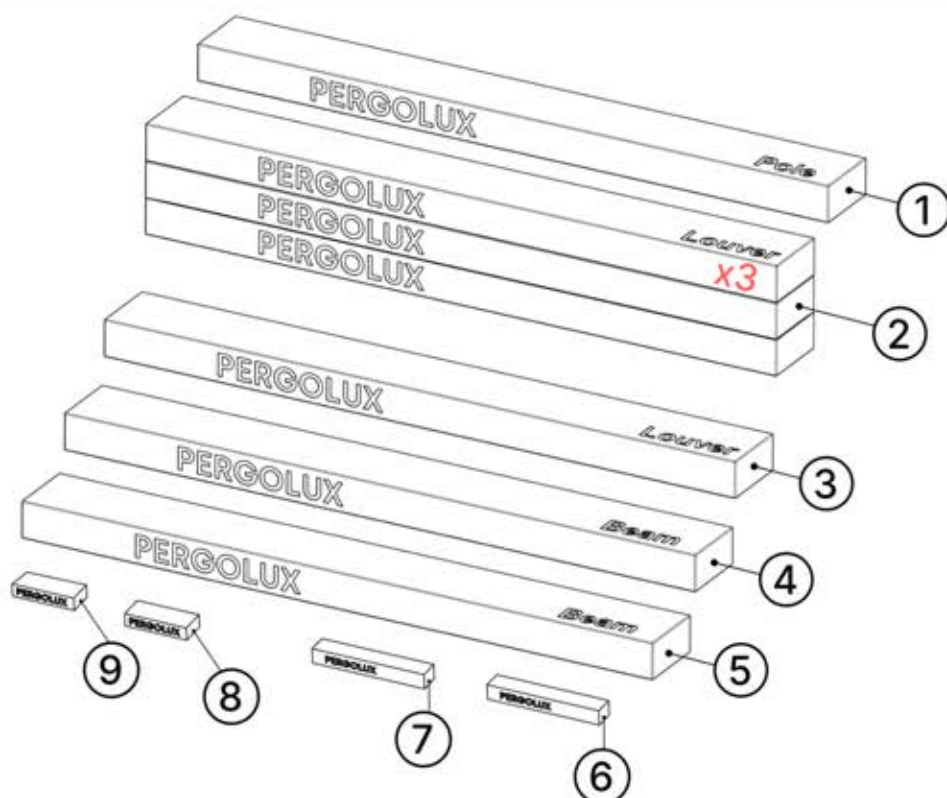



CONTENU DES COLIS

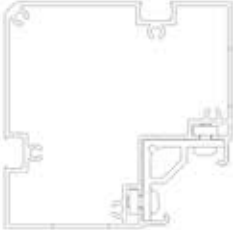

ORDER	ANTHRACITE	BLANC	NOIR
①	C120	C122	C121
②	L222	L226	L224
③	L234	L238	L236
④	B245	B253	B249
⑤	B263	B267	B265
⑥	BLANC / RGB LED		
⑦	MOTEUR		
⑧	BOÎTIER DE COMMANDE		
⑨	CÂBLE D'ALIMENTATION		

CONTENU DES COLIS

	ANTHRACITE	BLANC	NOIR
	C120	C122	C121
		<p>PN-200002606 2x</p>	
		<p>PN-200003386 2x</p>	
		<p>PN-200002614 2x</p>	

CONTENU DES COLIS

	ANTHRACITE	BLANC	NOIR
	L222	L226	L224

2

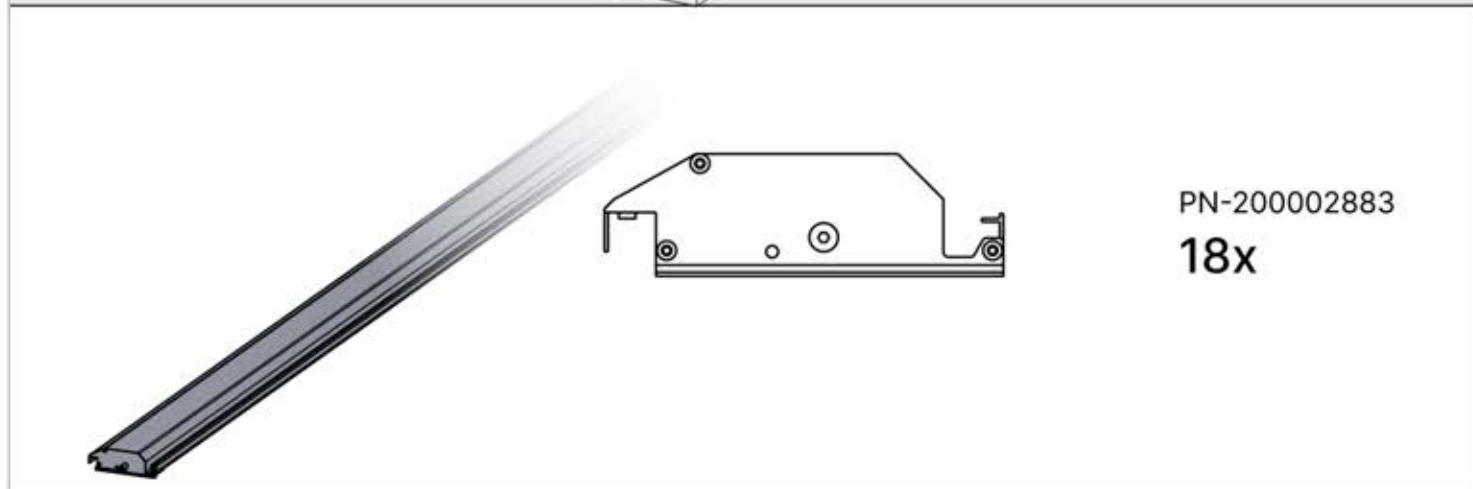





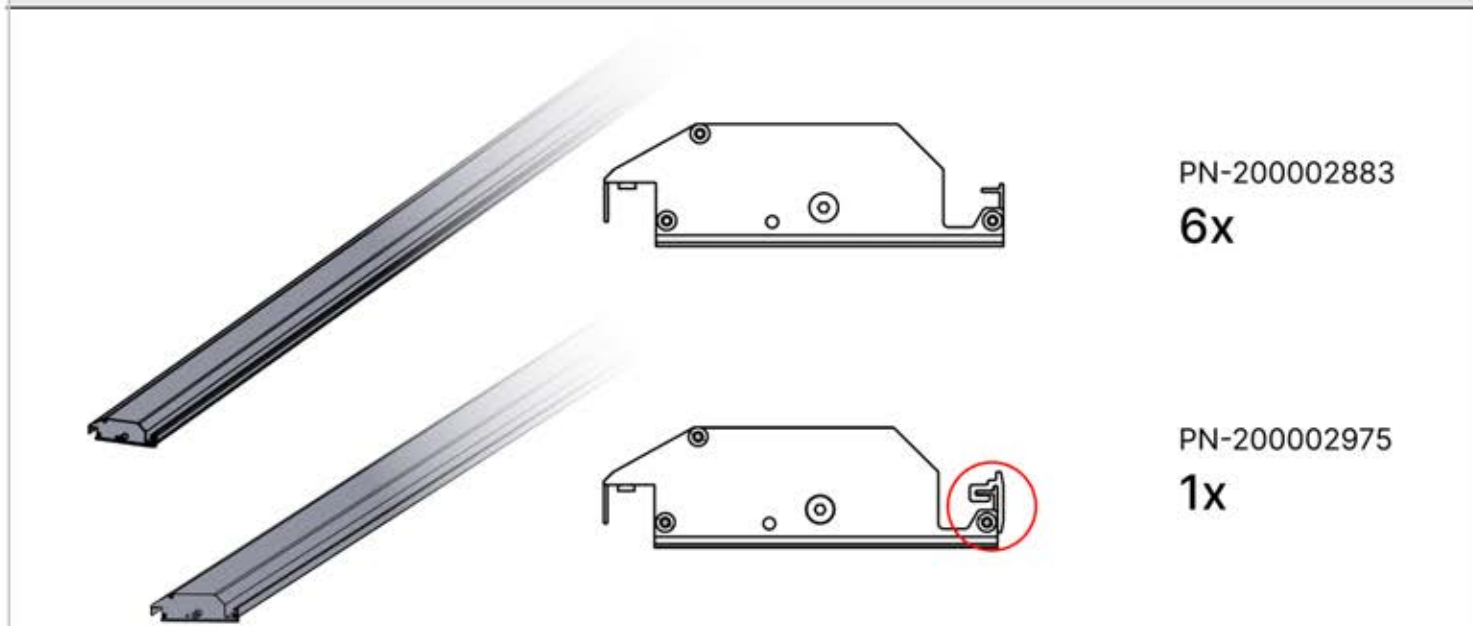



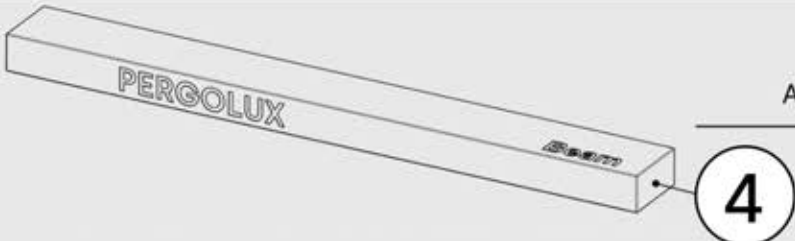

	ANTHRACITE	BLANC	NOIR
	L234	L238	L236

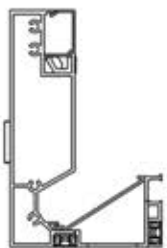
3

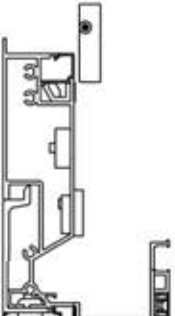

CONTENU DES COLIS

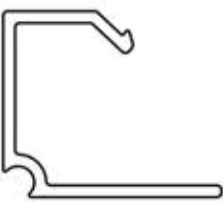
	ANTHRACITE	BLANC	NOIR
	B245	B253	B249

		<p>PN-200003283 1x</p>
		<p>PN-200003388 1x</p>
		<p>PN-200002609 1x</p>
		<p>PN-200002623 1x</p>
		<p>PN-200002613 1x</p>

CONTENU DES COLIS

	ANTHRACITE	BLANC	NOIR
	4	B245	B253



PN-200002633
1x



PN-200003329
1x



PN-200003382
1x



PN-20000
3326

5.5x60
7/32" x
2-3/8"



PN-200000560
10x



PN-20000
3320



PN-200000826
2x



PN-20000
3302



PN-200001514
4x



PN-200003322
1x



PN-200003323
1x



PN-200000840
18x

CONTENU DES COLIS



4

ANTHRACITE BLANC NOIR

B245

B253

B249

PN-20000
Zip Bag
3278



PN-200003030
1x

PN-200003031
1x



PN-200003033
2x

PN-200001207
2x

PN-20000
Zip Bag
3279



PN-200000568
32x

PN-20000
Zip Bag
3379



PN-200000960
4x

PN-20000
Zip Bag
3276



PN-200002618
4x



PN-200000571
4x

PN-20000
Zip Bag
3365



PN-200000507
4x



PN-200000568
34x



PN-200000569
8x



PN-200000516
1x

PN-20000
Zip Bag
3364



















PN-200002792
2x



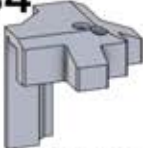

PN-200002617
4x

CONTENU DES COLIS

	ANTHRACITE	BLANC	NOIR
	B245	B253	B249
	4		
 PN-20000 3371 	PN-200003372 1x		PN-200003373 1x
	PN-200001946 1x		PN-200000561 1x
	PN-200000502 1x		
			
			
 PN-20000 3281 	PN-200002622 4x		PN-200000510 5x
	PN-200000680 8x		PN-200000669 5x
 PN-20000 3284 	PN-200002625 4x		PN-200000655 5x
 PN-20000 3309 	PN-200003308 2x		PN-200003209 1x
	PN-200003324 2x		
			

CONTENU DES COLIS

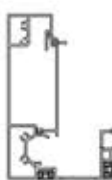
	ANTHRACITE	BLANC	NOIR
	5	B263	B267

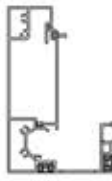
		PN-200003358 1x
		PN-200003359 1x
		Pré-monté PN-200003557 2x

CONTENU DES COLIS



6

BLANC / RGB LED



LED light strip

4x



PN-200001562

1x



7

MOTEUR



Electric motor
PN-200001562

1x



PN-200001623

1x



PN-200001624

1x



Bandeau LED

2x

CONTENU DES COLIS



** Si LEDs dans votre commande



8

BOÎTIER DE COMMANDE



Boîtier de commande
1x



PN-200002756
1x



Matter antenna clip
1x



PN-200002754
1x



PN-200002684
10x



PN-200002758
1x



PN-200002683
5x



PN-200002753
2x



QR-code
1x



PN-200002759
2x



3M tape
1x



PN-200002757
1x

CONTENU DES COLIS



** Si LEDs dans votre commande



9

CÂBLE D'ALIMENTATION



Câble
d'alimentation
1x



Tous les composants électriques doivent être testés avant l'installation.

Les leds + le moteur (et la lampe chauffante) doivent être connectés au boîtier de commande et programmés pour garantir leur bon fonctionnement.

Matter + smart home peuvent être connectés à tout moment en scannant simplement le code QR fourni.



BOÎTIER DE COMMANDE

[View Manual](#)

4 x 4 M / 13' x 13'

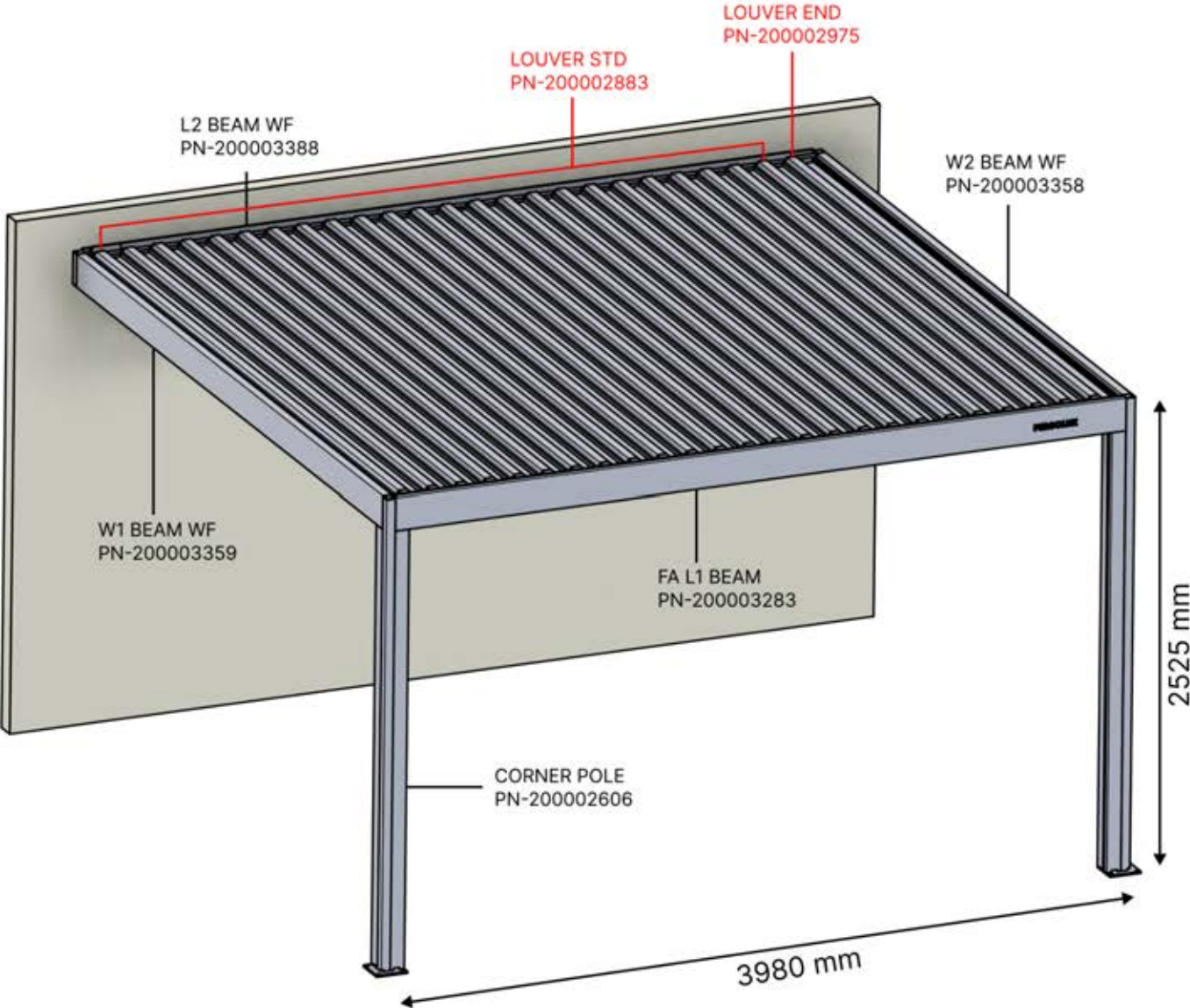

4 x 4 M / 13' x 13'

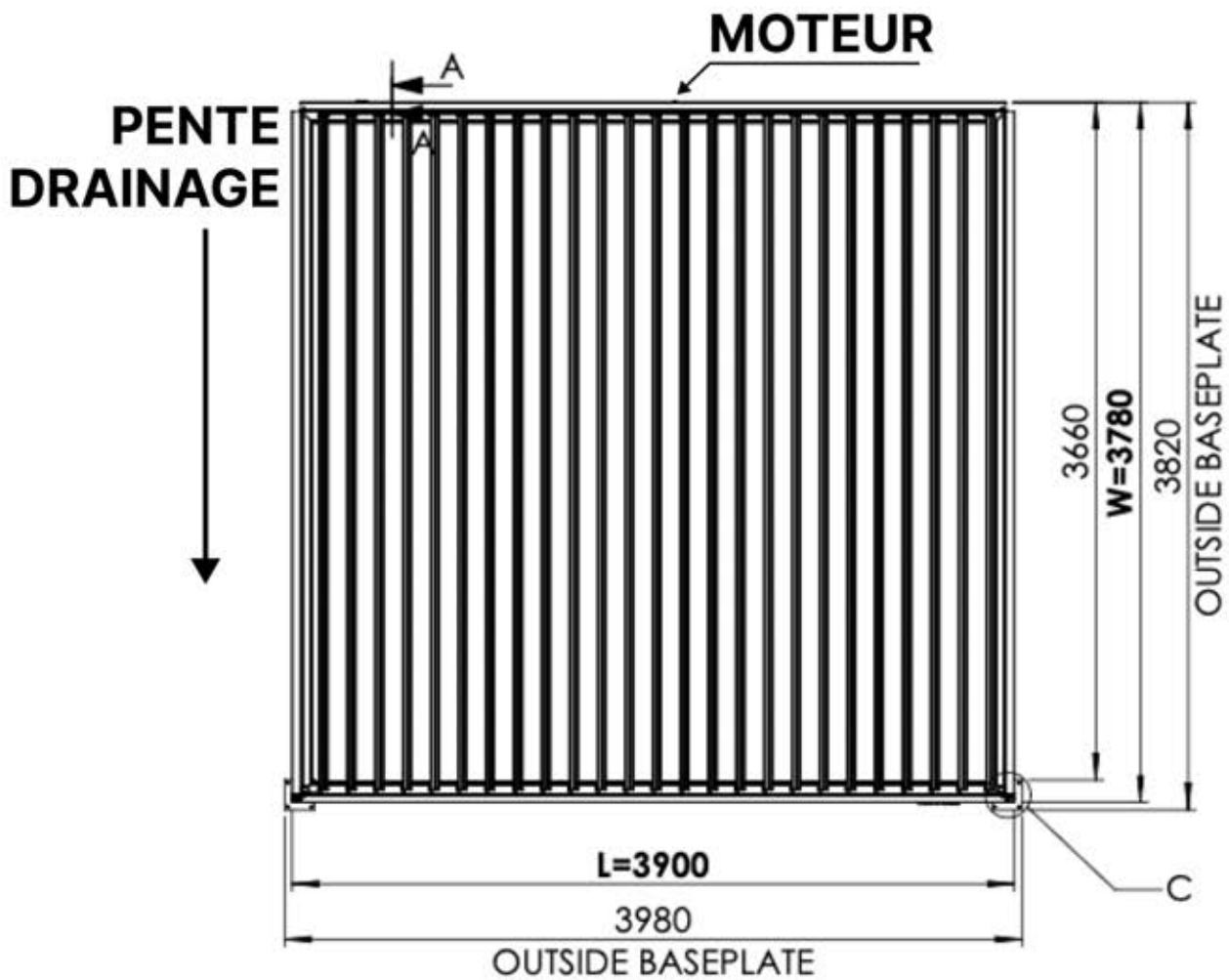
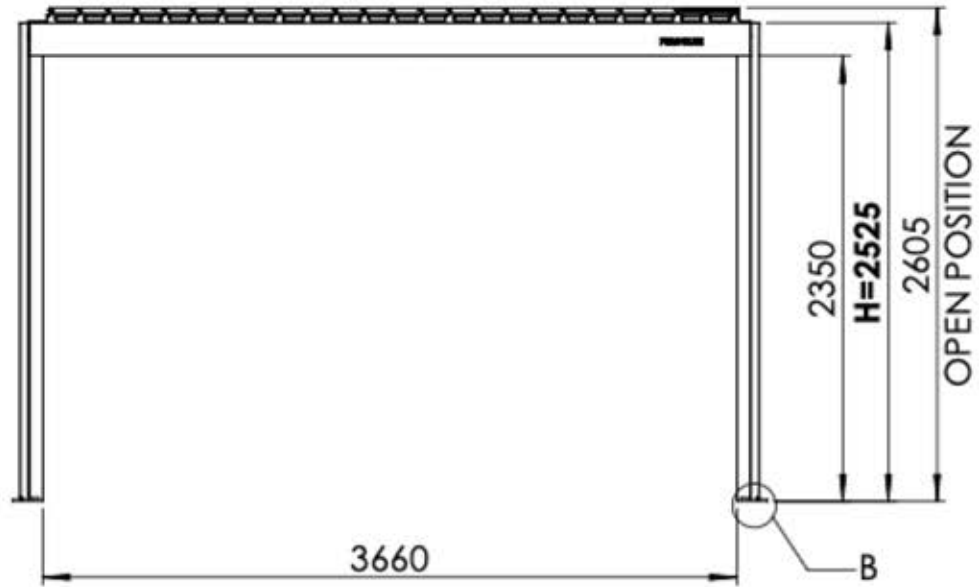

INFORMATION

Allez-vous installer des persiennes, des parois vitrées ou des stores ?

Il est recommandé de retirer ces caches rubans led et ces clips maintenant, avant d'installer la pergola.

Cache et clips



PN-200000512
Clip de fixation Snapfit



Cache SnapFIT

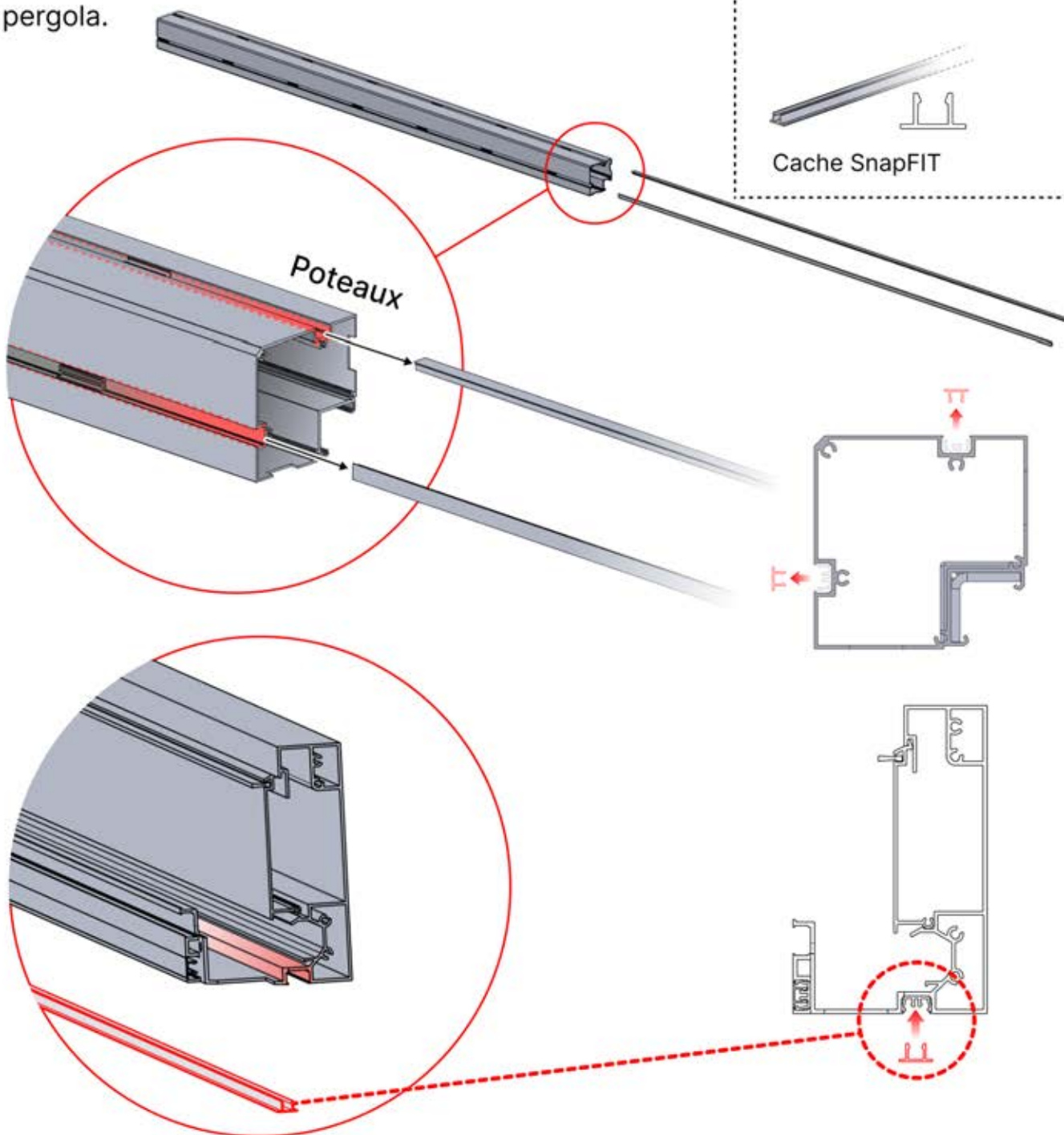

INFORMATION

Installez-vous une
lampe chauffante, un
ventilateur ou des
lumières LED ?

Il est recommandé de retirer les
deux caches Snap-fit de la poutre
dès maintenant.

Cache et clips



PN-200000512
Clip de fixation Snapfit



Cache SnapFIT

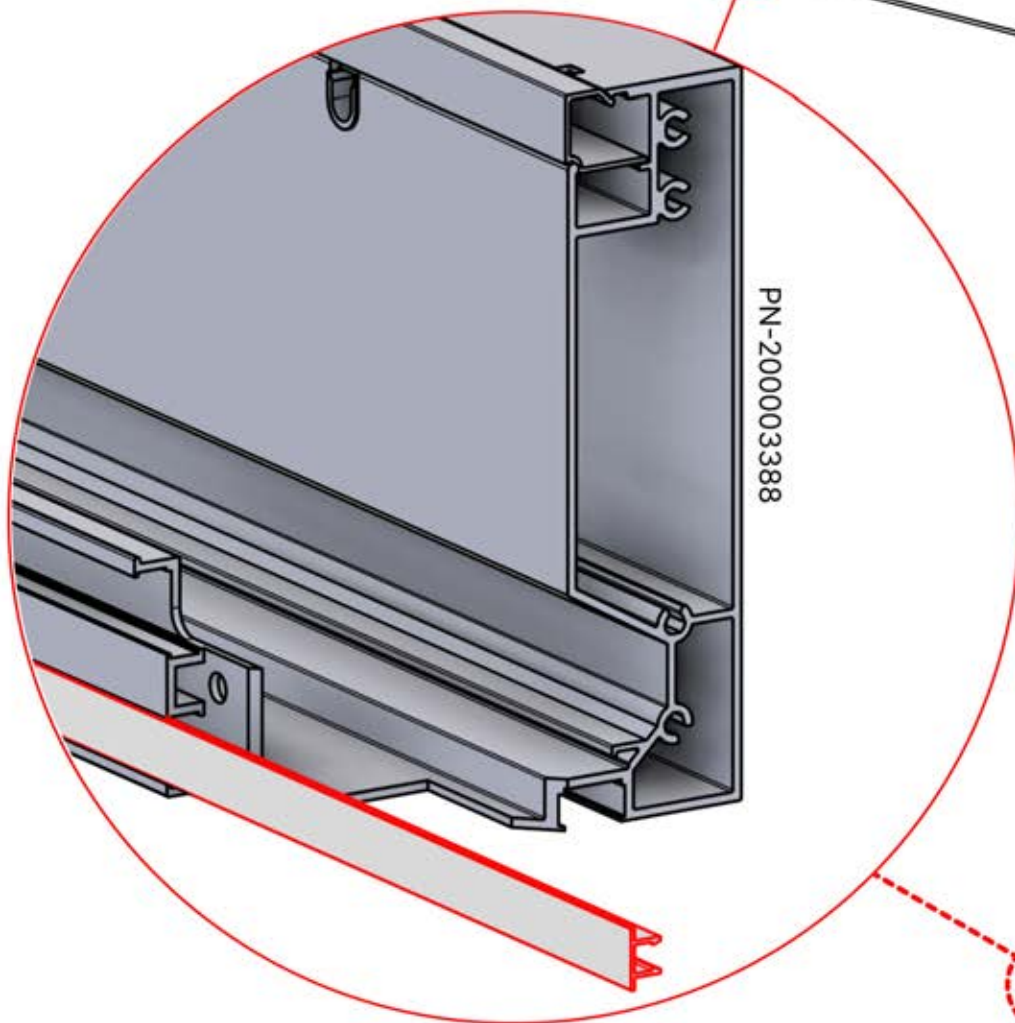

PN-200003388

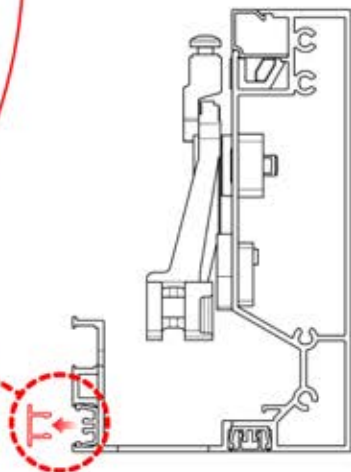

INFORMATION

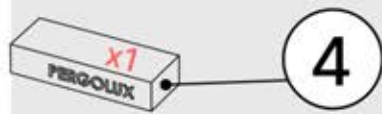

ANTHRACITE: B245
BLANC: B253
NOIR: B249

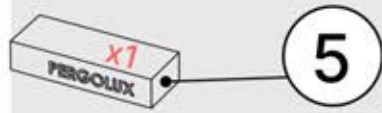

ANTHRACITE: B263
BLANC: B267
NOIR: B265

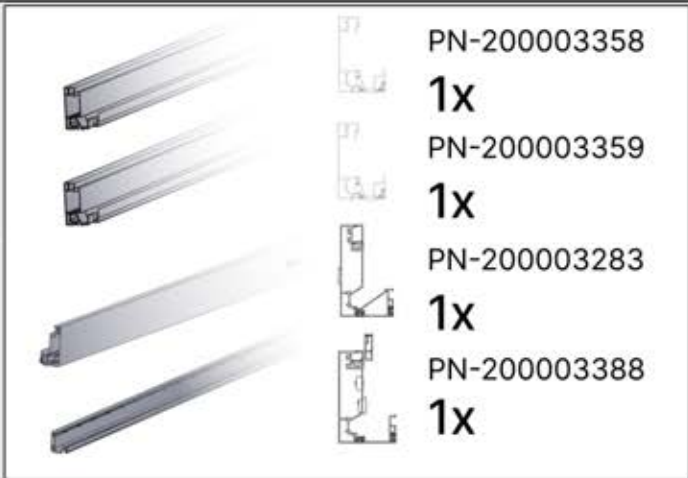

PN-200003283

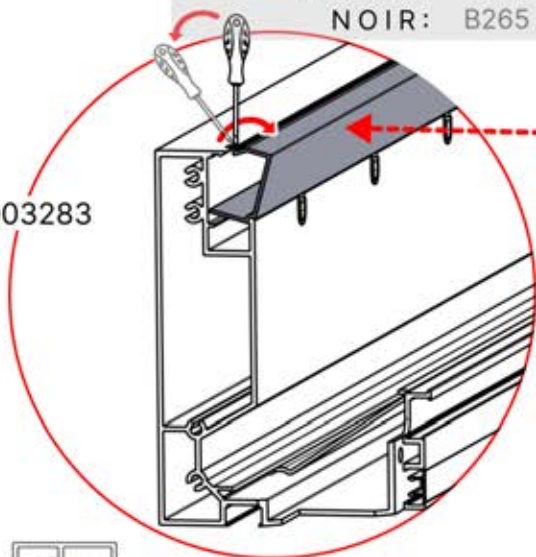

PN-200003358

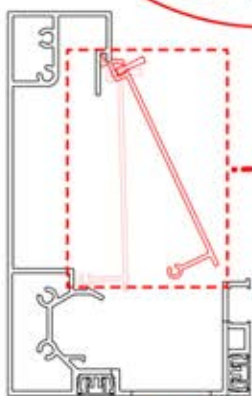
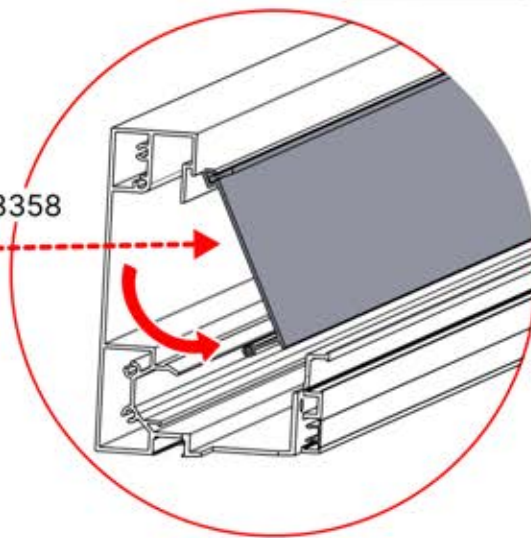

PN-200003388

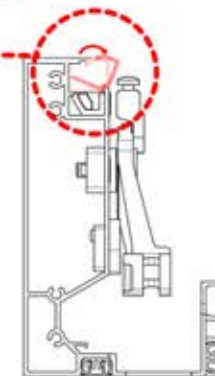

01

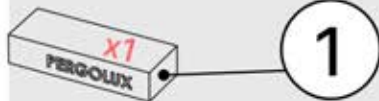

ANTHRACITE: C120
BLANC: C122
NOIR: C121

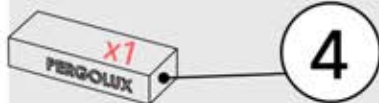

ANTHRACITE: B245
BLANC: B253
NOIR: B249



PN-200002606
2x



PN-200002614
2x

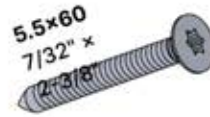

PN-200000560
10x

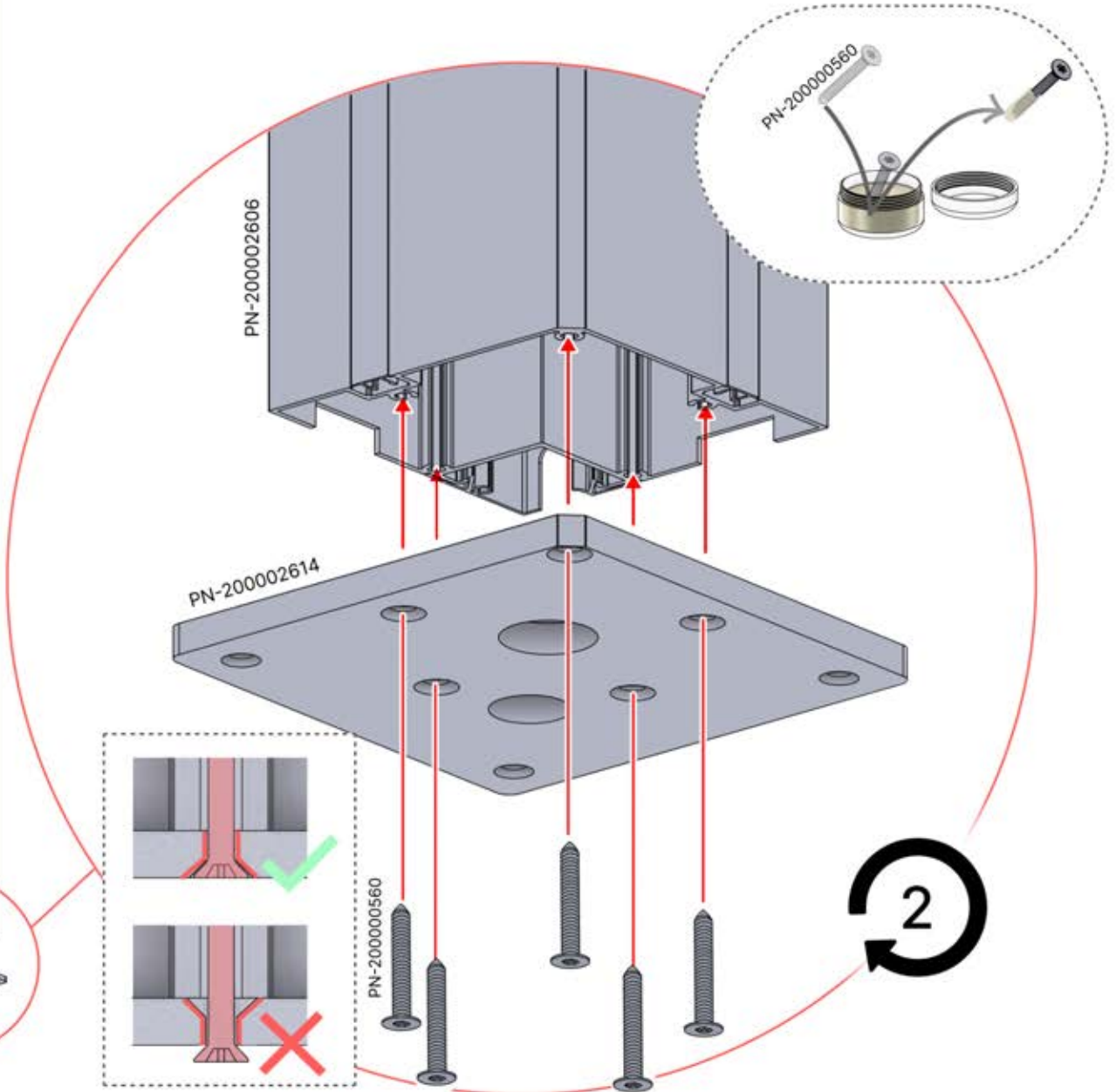
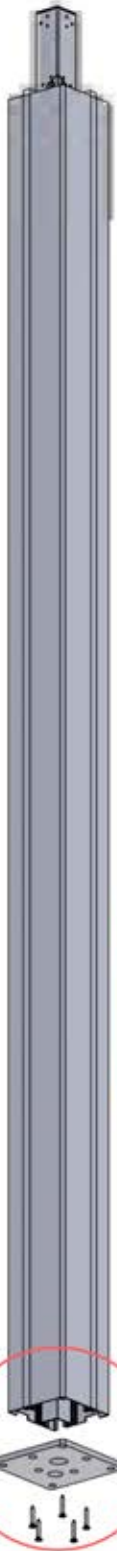

02



4

ANTHRACITE: B245
BLANC: B253
NOIR: B249



PN-200000510
5x

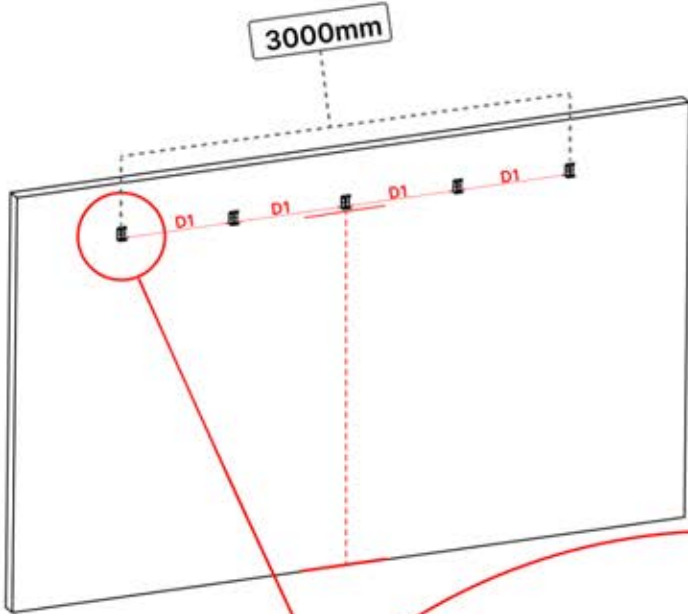

x10



Installez les premier et dernier supports muraux (réf. PN-200000510) à une distance de 3 000 mm l'un de l'autre. Placez les supports restants entre les deux, en veillant à ce qu'ils soient répartis de manière uniforme.

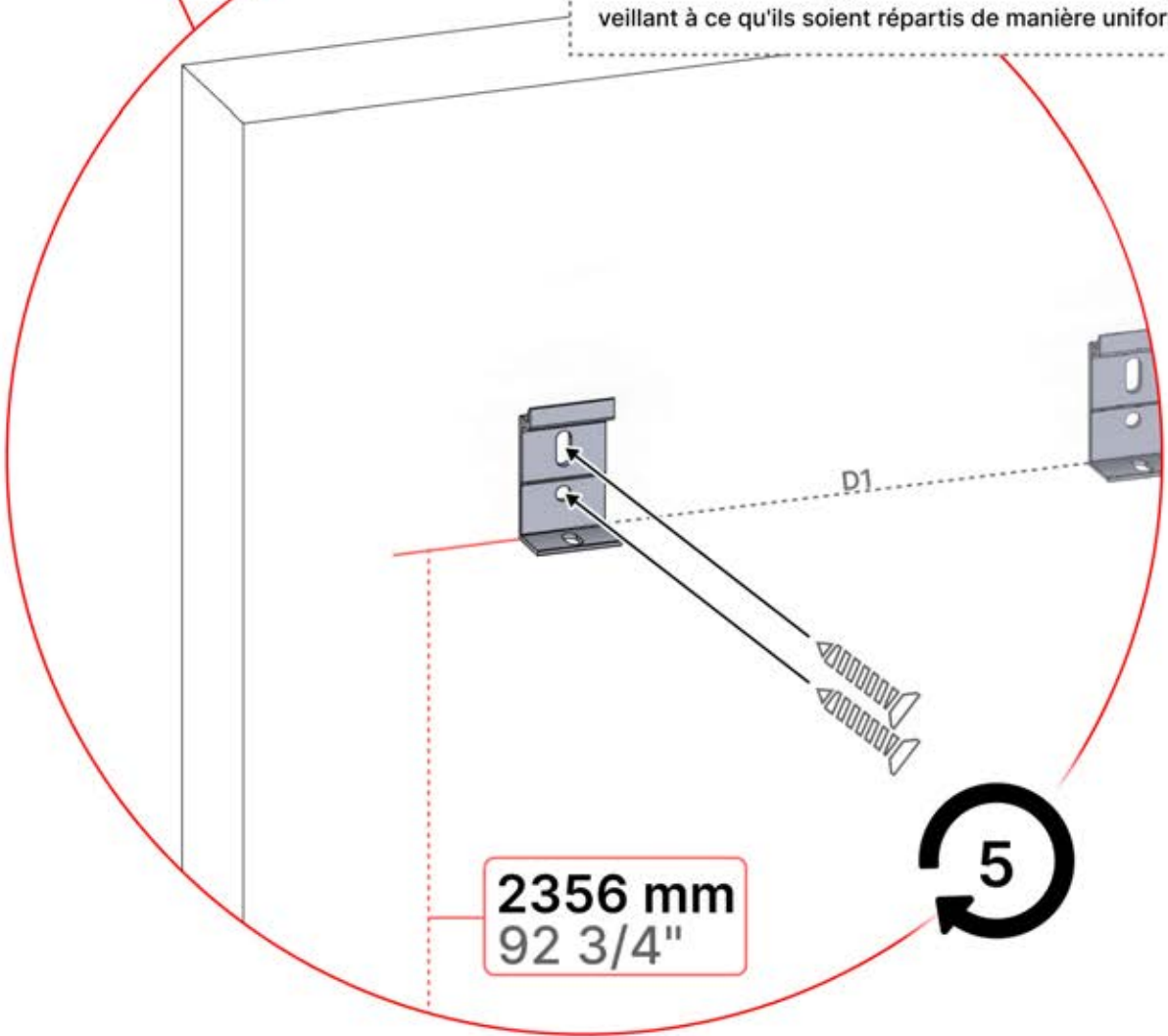

5

03

x7
PERGOLUX

4

ANTHRACITE: B245
BLANC: B253
NOIR: B249



PN-200003388
1x

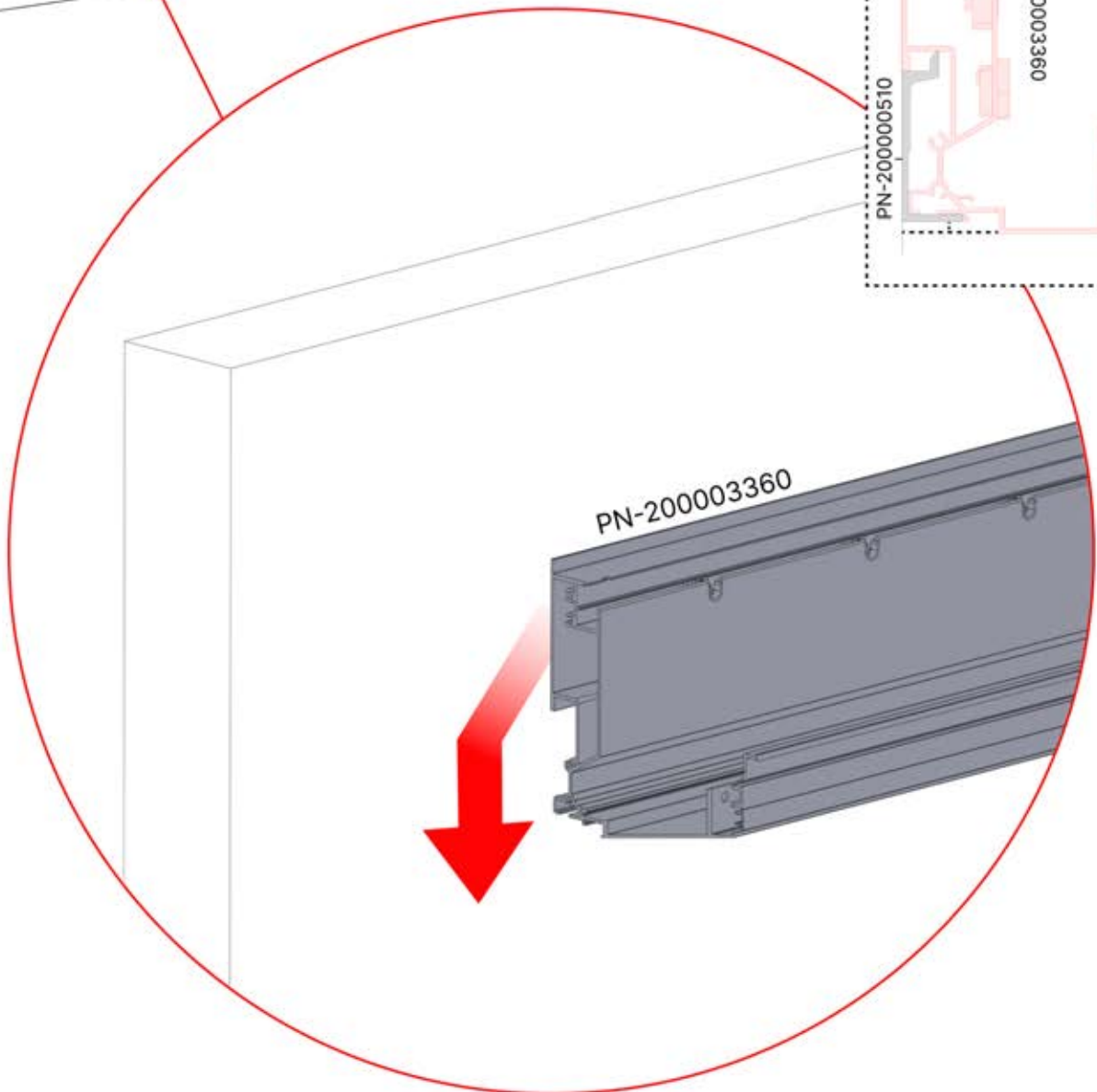
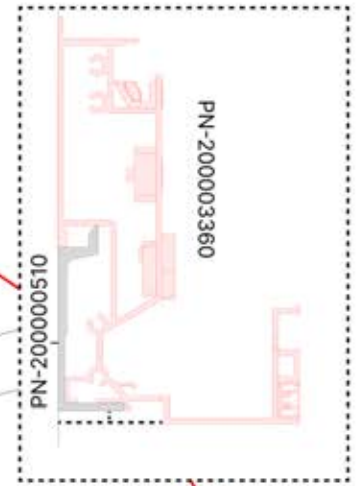

05

 **x1**
PERGOLUX

4

ANTHRACITE: B245
BLANC: B253
NOIR: B249



PN-200000655
5x

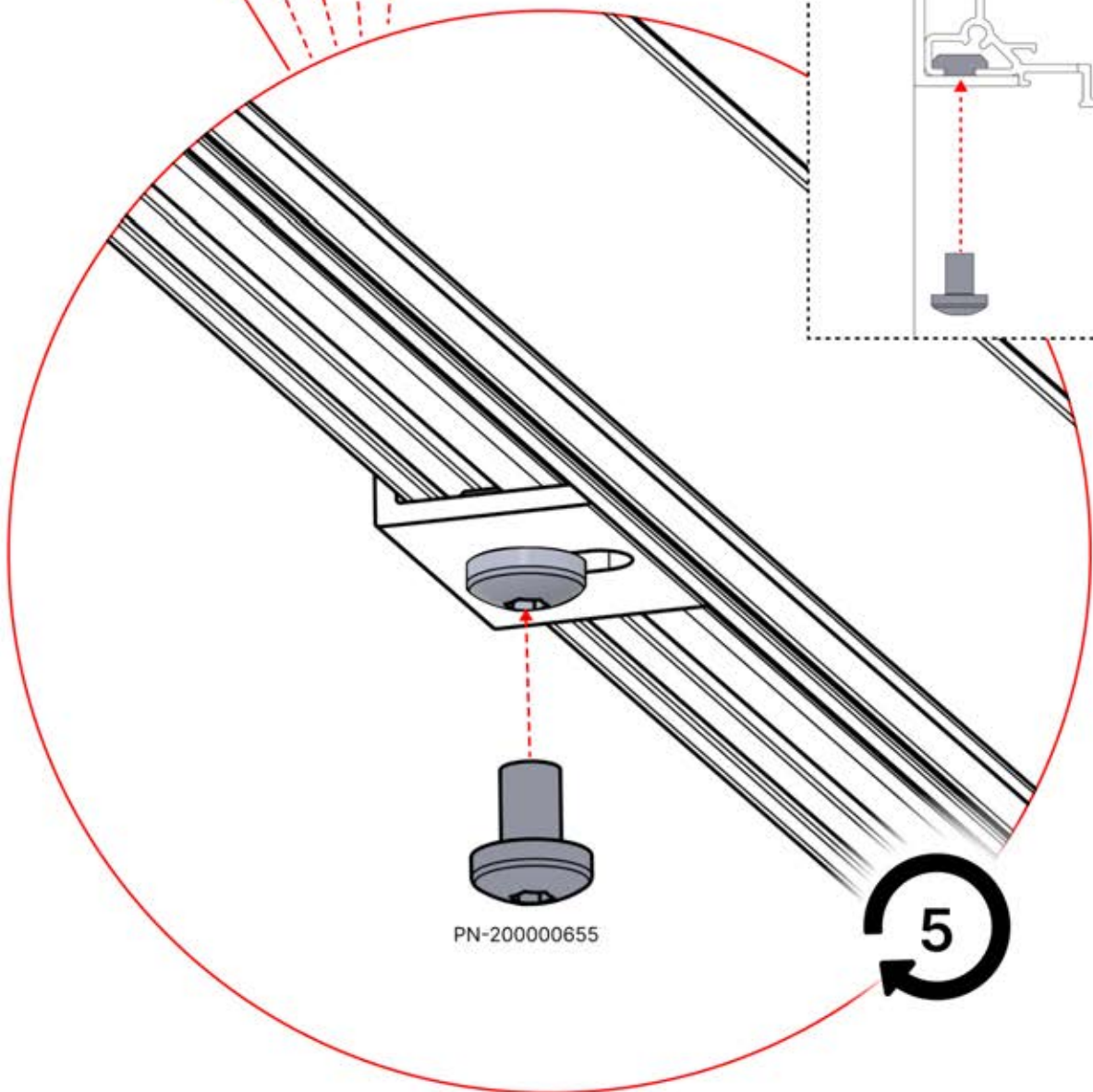
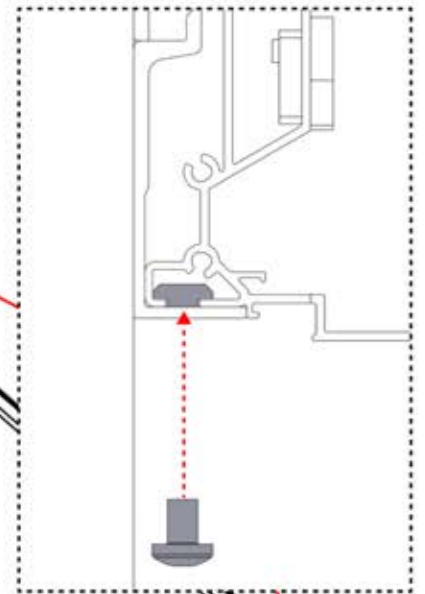
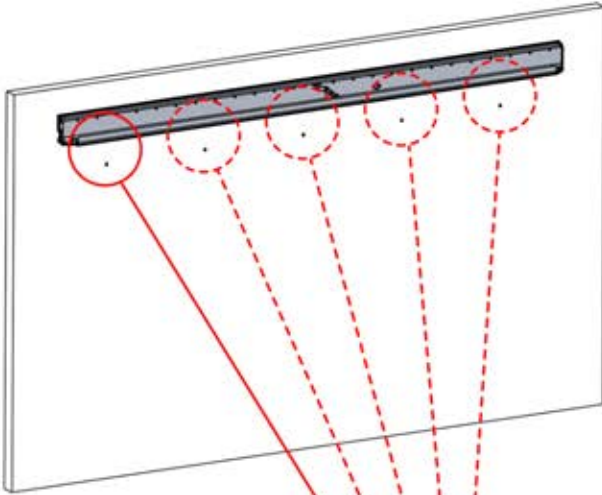

06

4

x1
FERGOLUX

ANTHRACITE: B245
BLANC: B253
NOIR: B249

5

x1
FERGOLUX

ANTHRACITE: B263
BLANC: B267
NOIR: B265



PN-200003358
1x

PN-200003359
1x

PN-200003308
2x

PN-200000568
8x

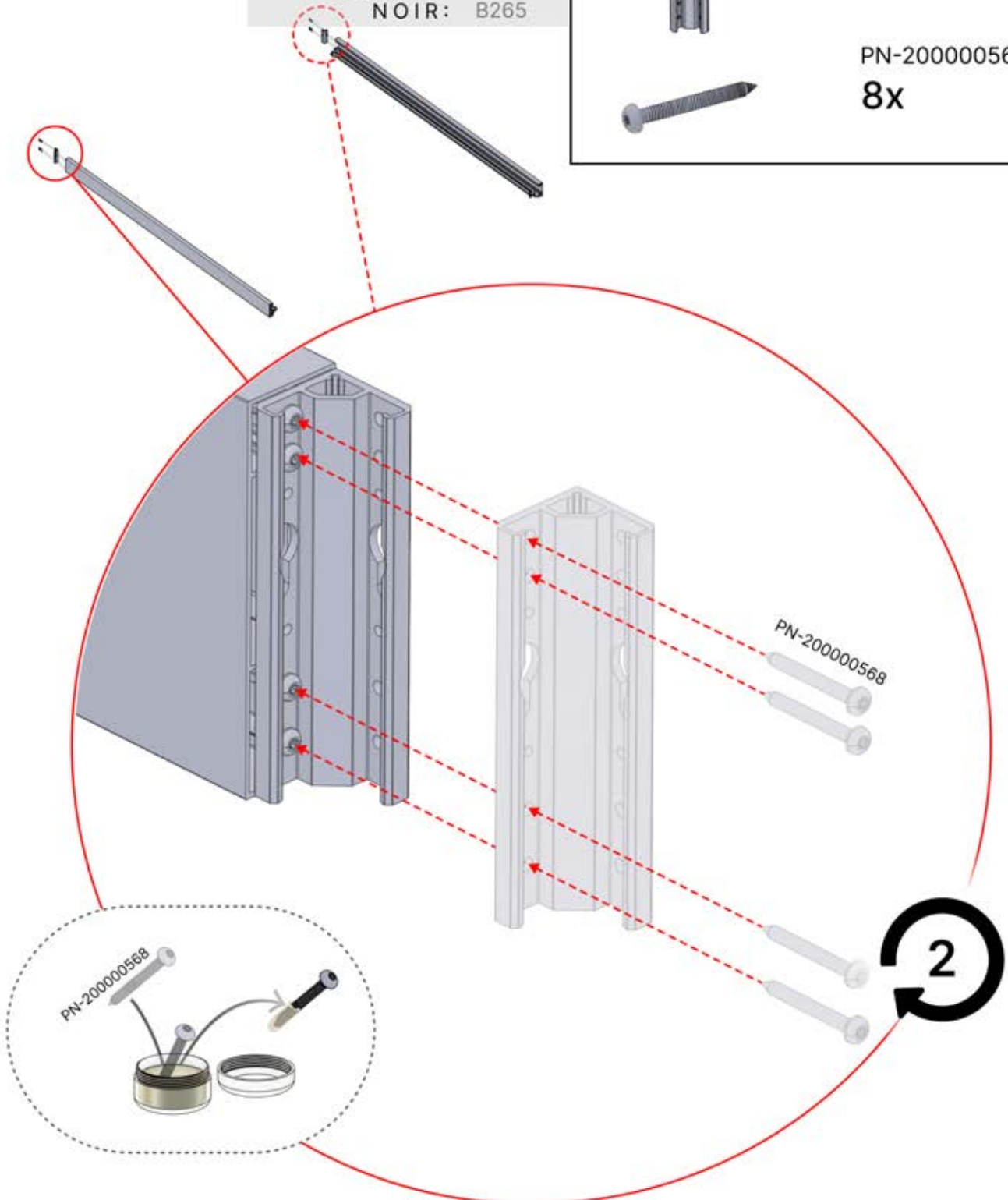

07

5

x7
PERGOLUX

ANTHRACITE: B263
BLANC: B267
NOIR: B265

4

x7
PERGOLUX

ANTHRACITE: B245
BLANC: B253
NOIR: B249



PN-200003358
1x

PN-200003359
1x

PN-200000568
8x

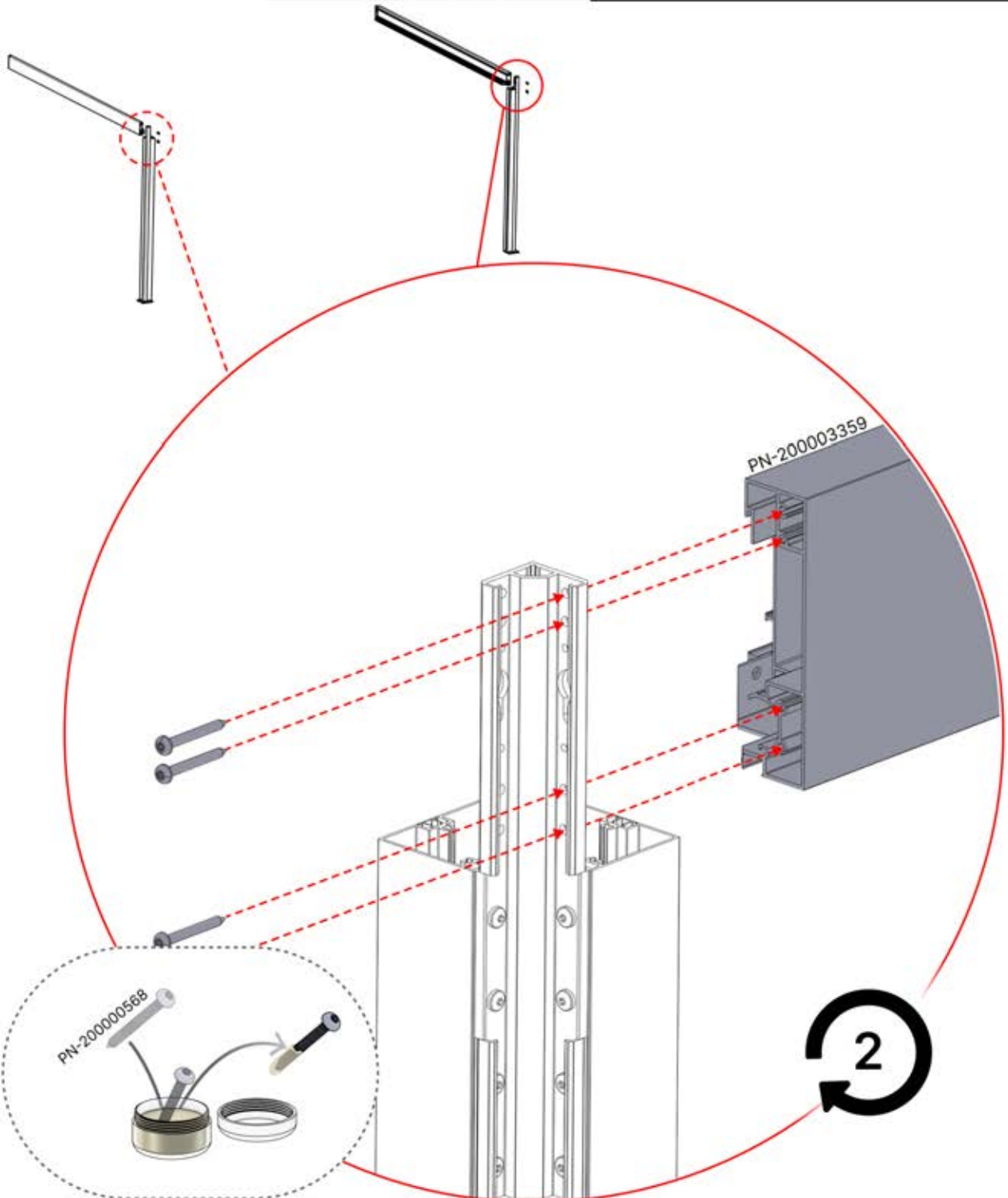

08

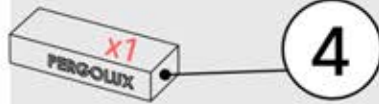

ANTHRACITE: B245
BLANC: B253
NOIR: B249

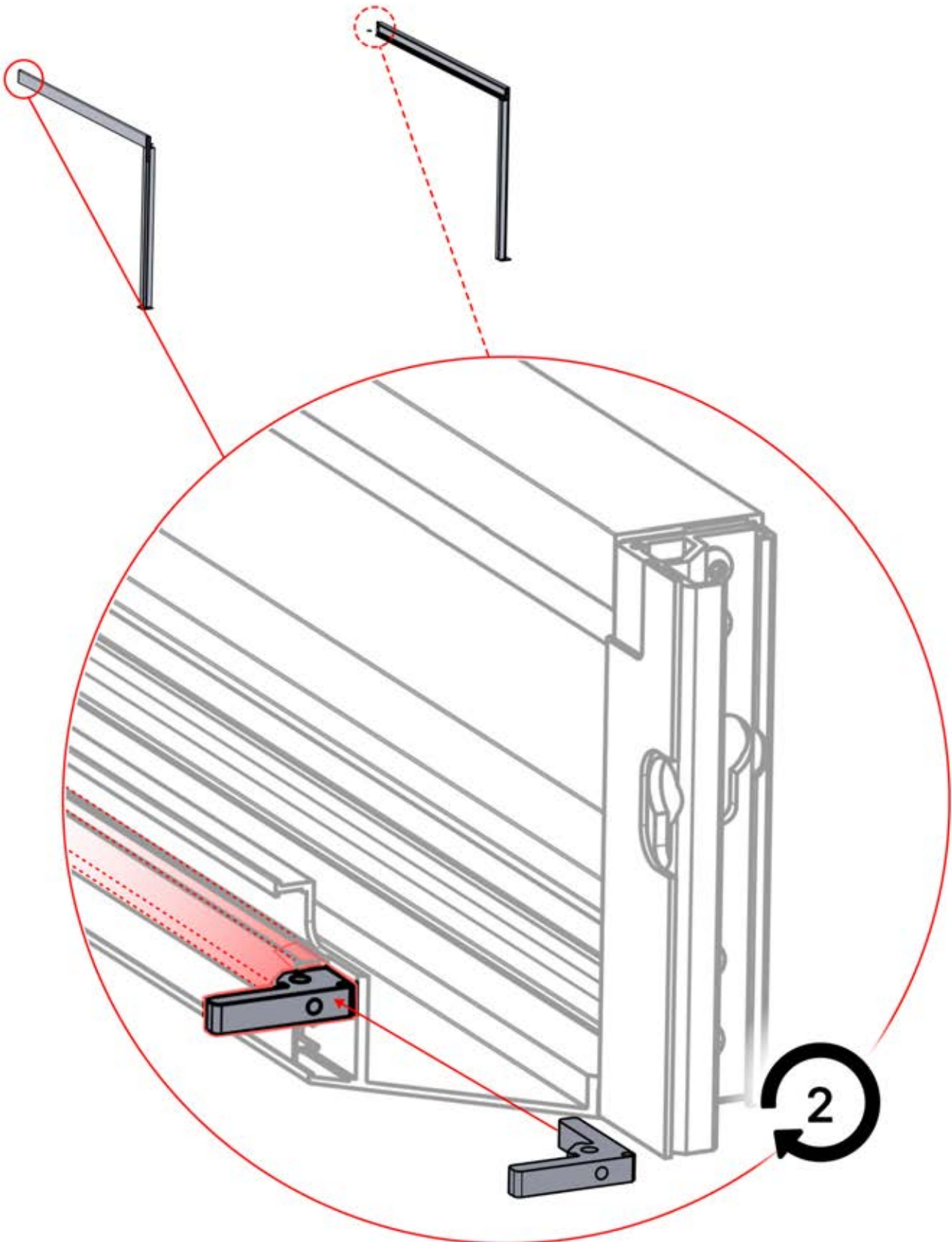
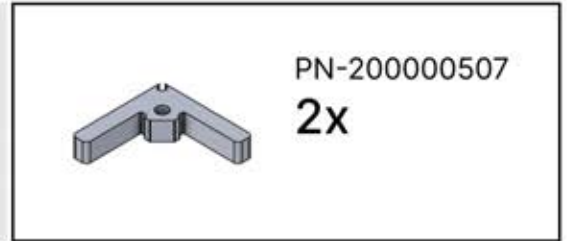

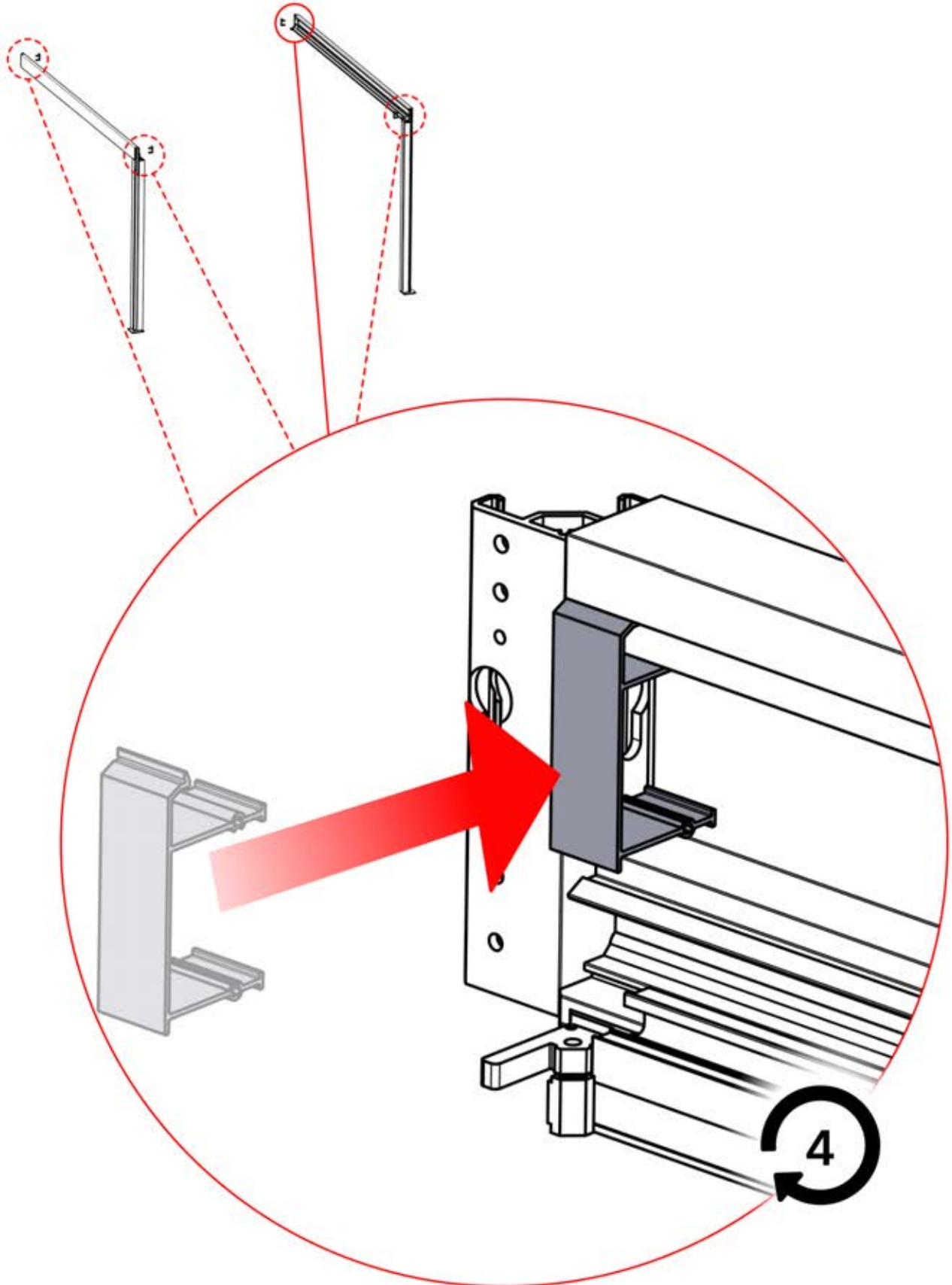

09

	4		PN-200002622
ANTHRACITE: B245			4x
BLANC: B253			
NOIR: B249			



10

	4		PN-200000680
ANTHRACITE: B245			8x
BLANC: B253			
NOIR: B249			

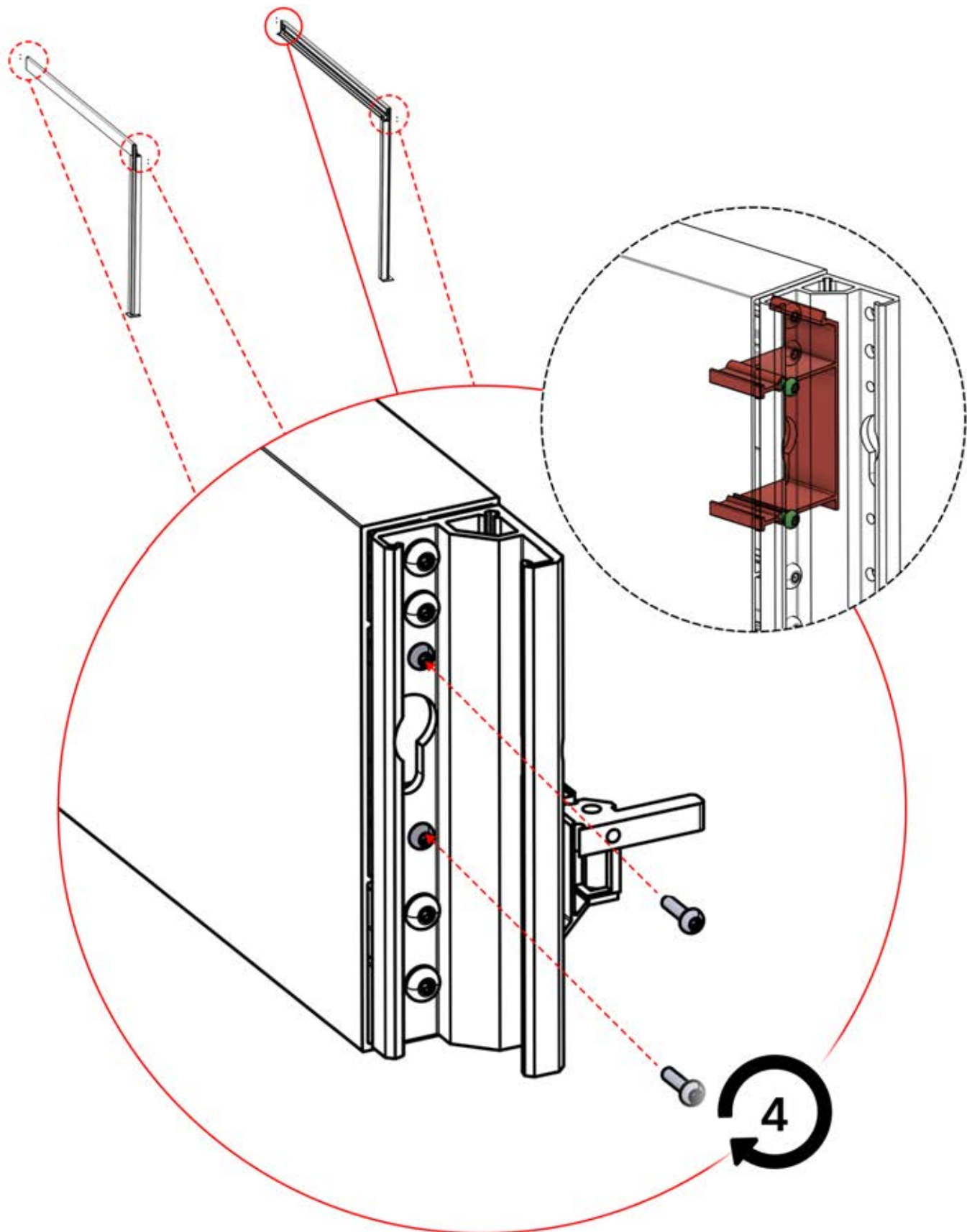

11

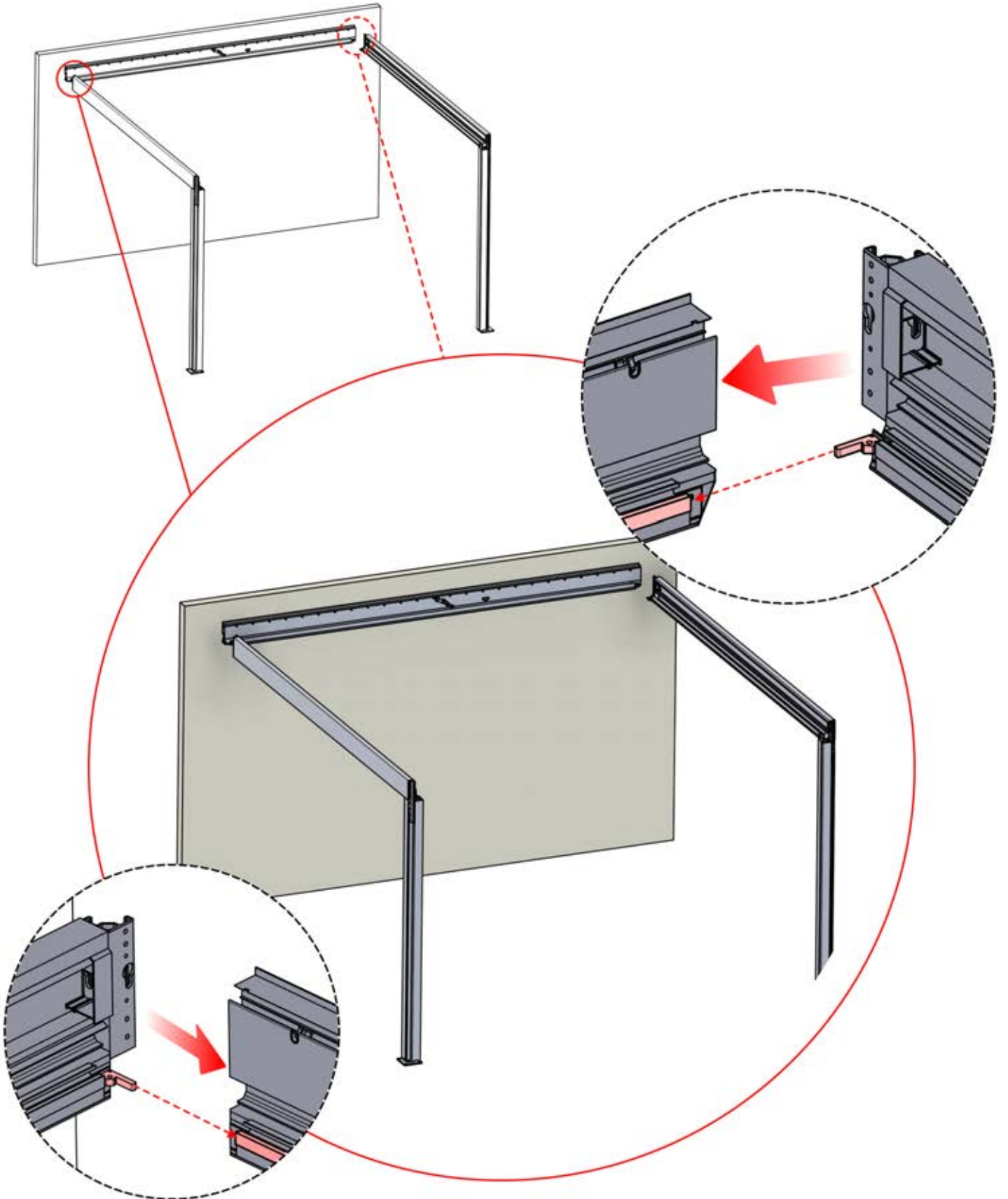

12



4

ANTHRACITE: B245
BLANC: B253
NOIR: B249

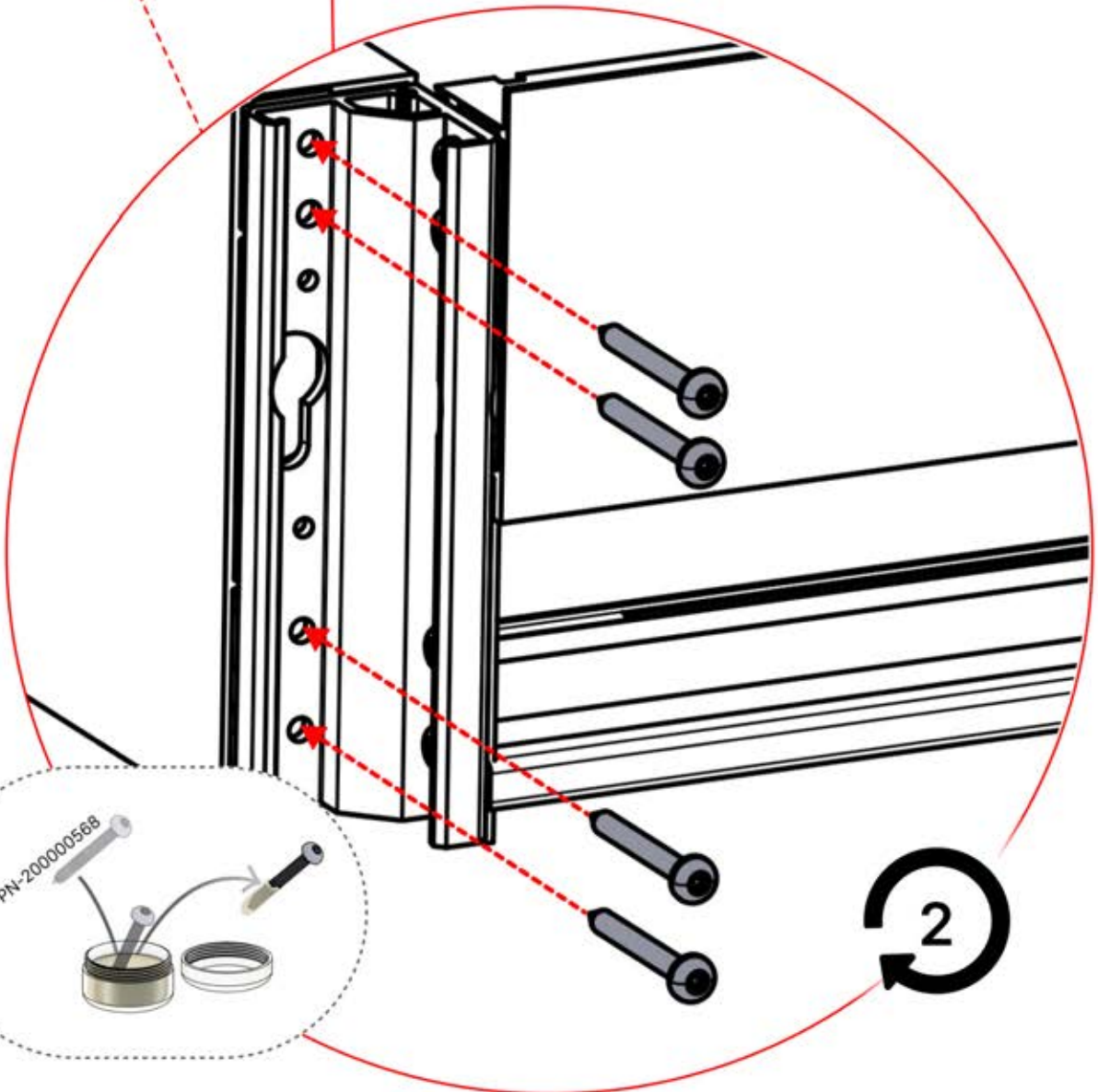
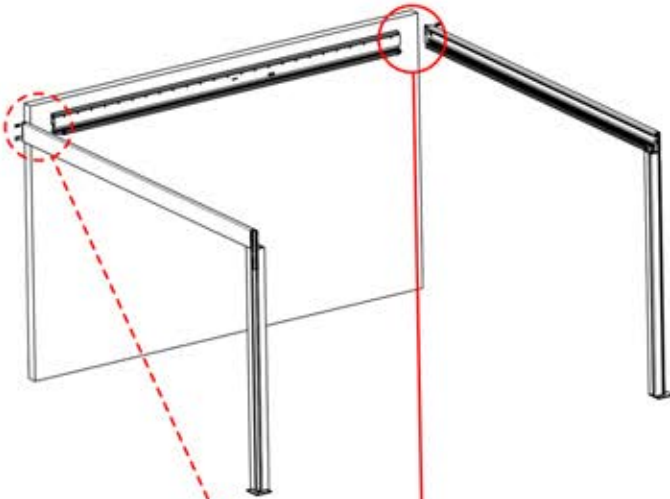
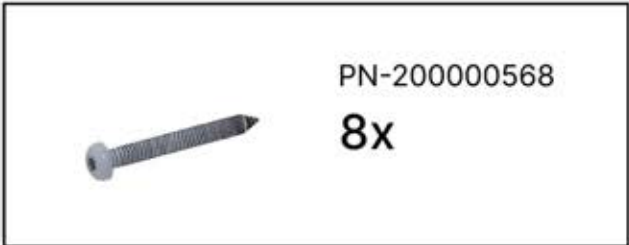

PN-200000568

2

13



4

ANTHRACITE: B245
BLANC: B253
NOIR: B249



PN-200000507

2x

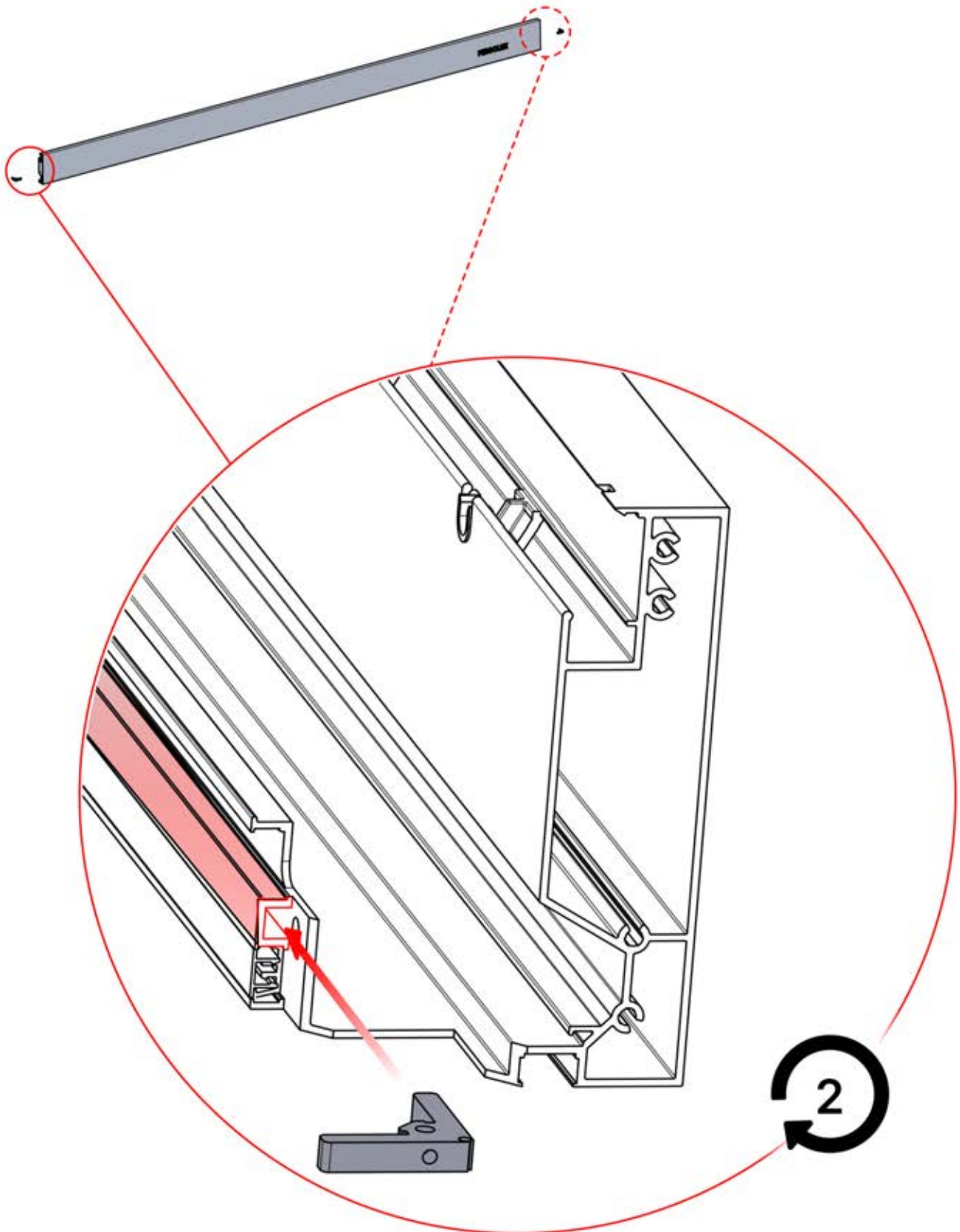

14



4

ANTHRACITE: B245
BLANC: B253
NOIR: B249



PN-200000507

2x

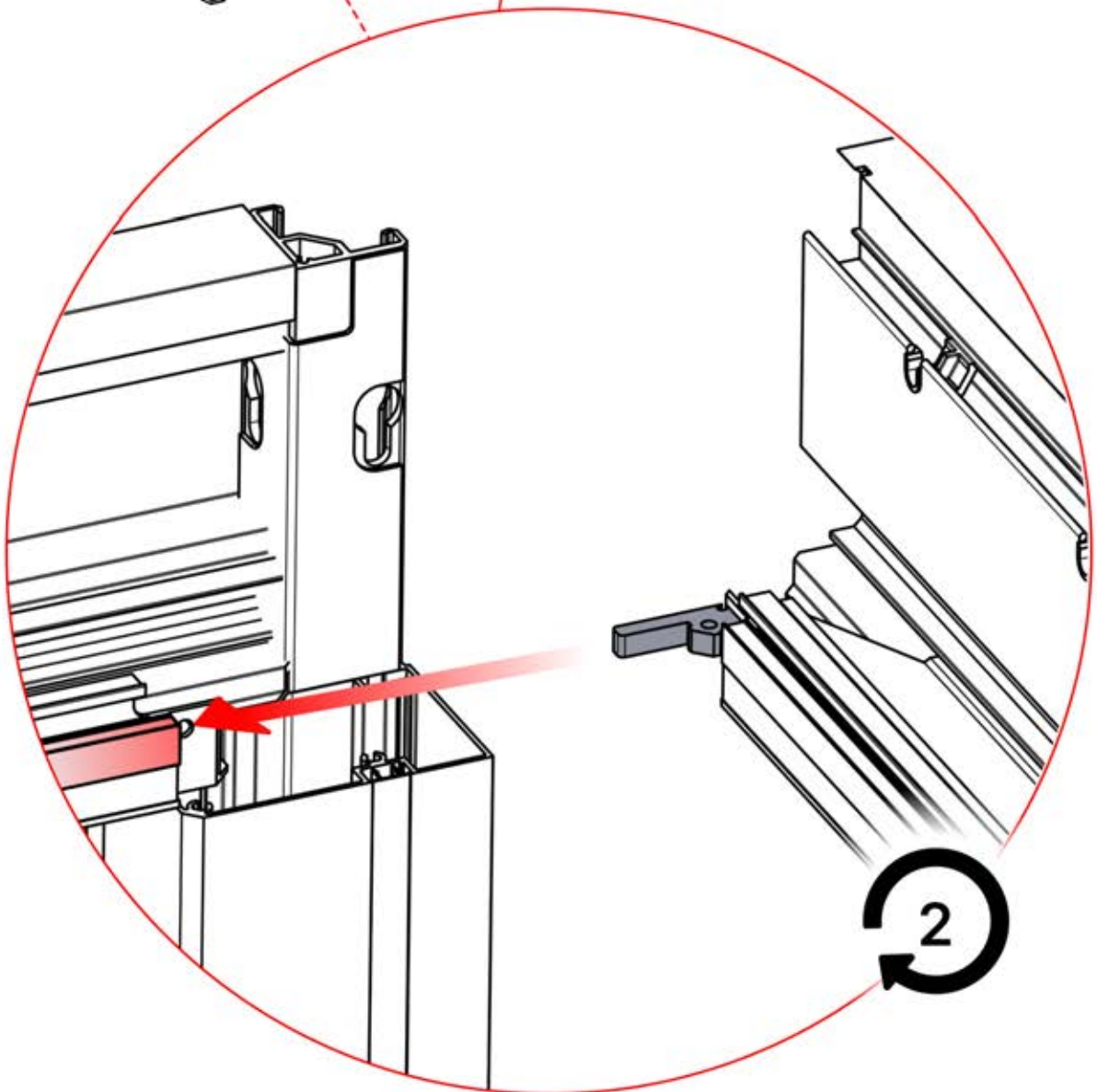
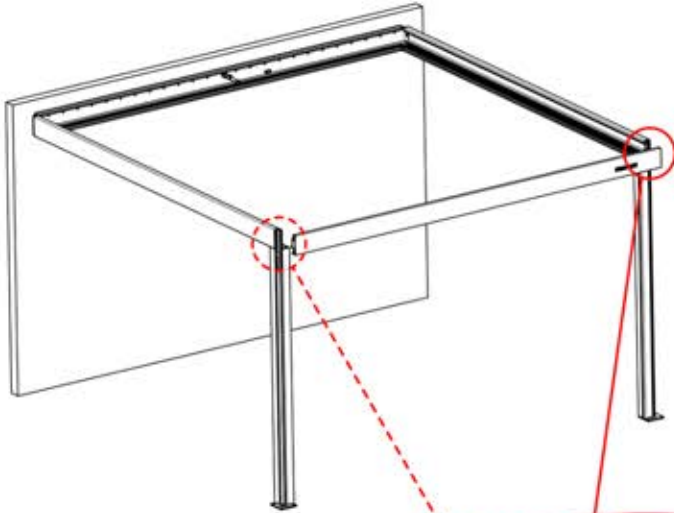

15

x1
PERGOLUX

4

ANTHRACITE: B245
BLANC: B253
NOIR: B249



PN-200000568
8x

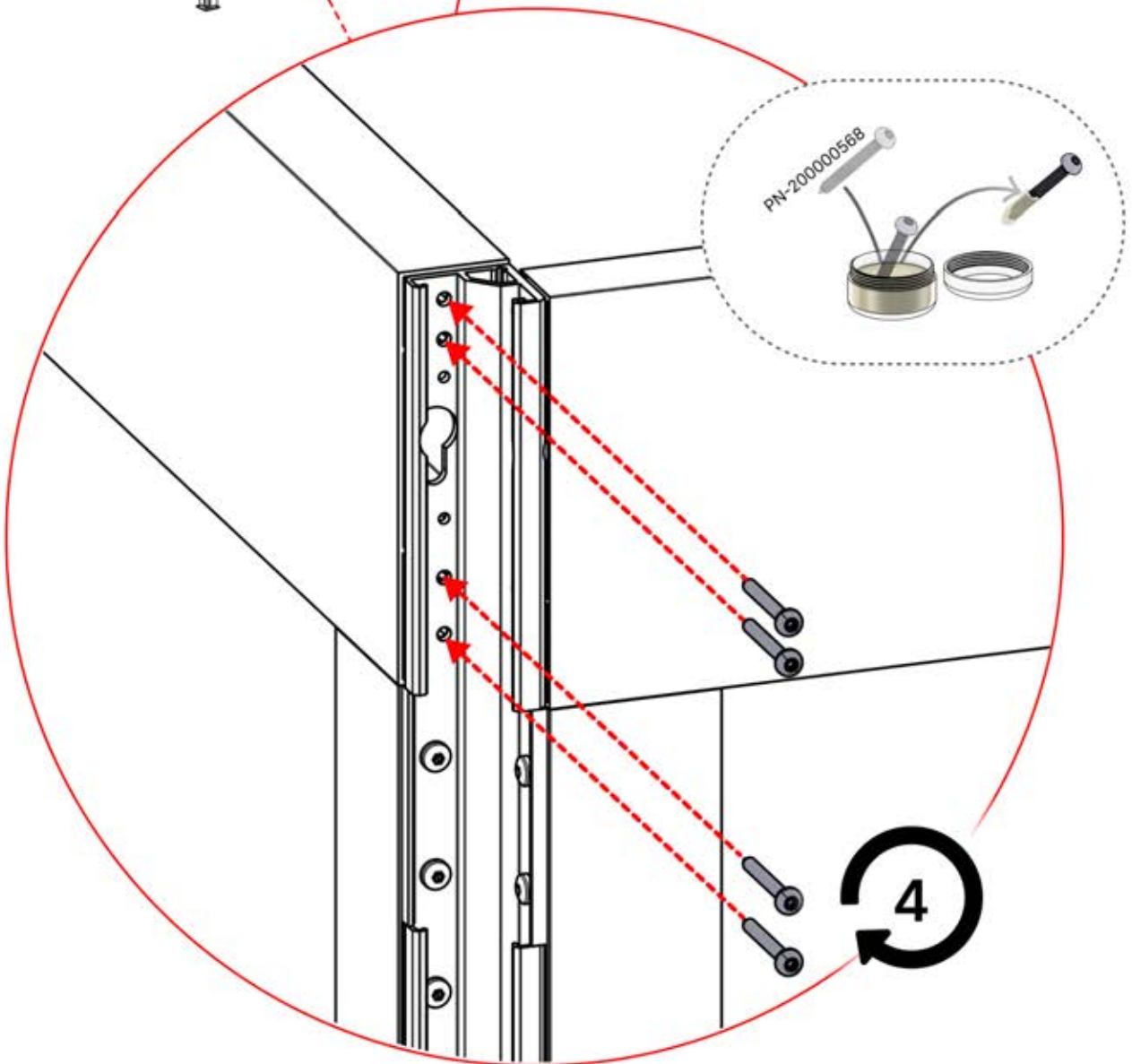
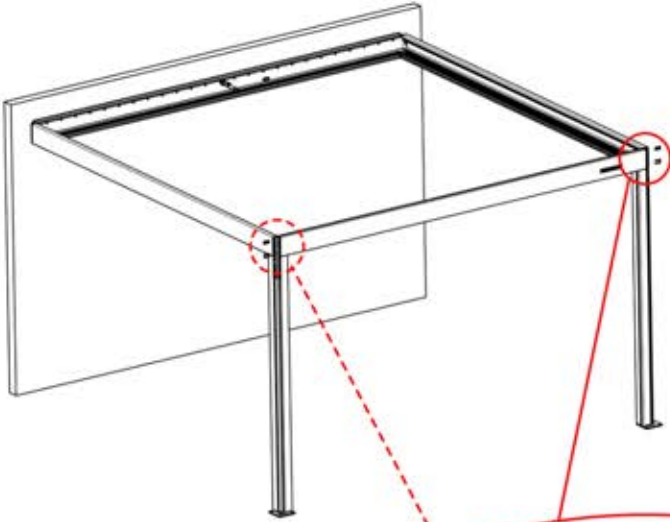

16

x1
PERGOLUX

4

ANTHRACITE: B245
BLANC: B253
NOIR: B249



PN-200000569
8x

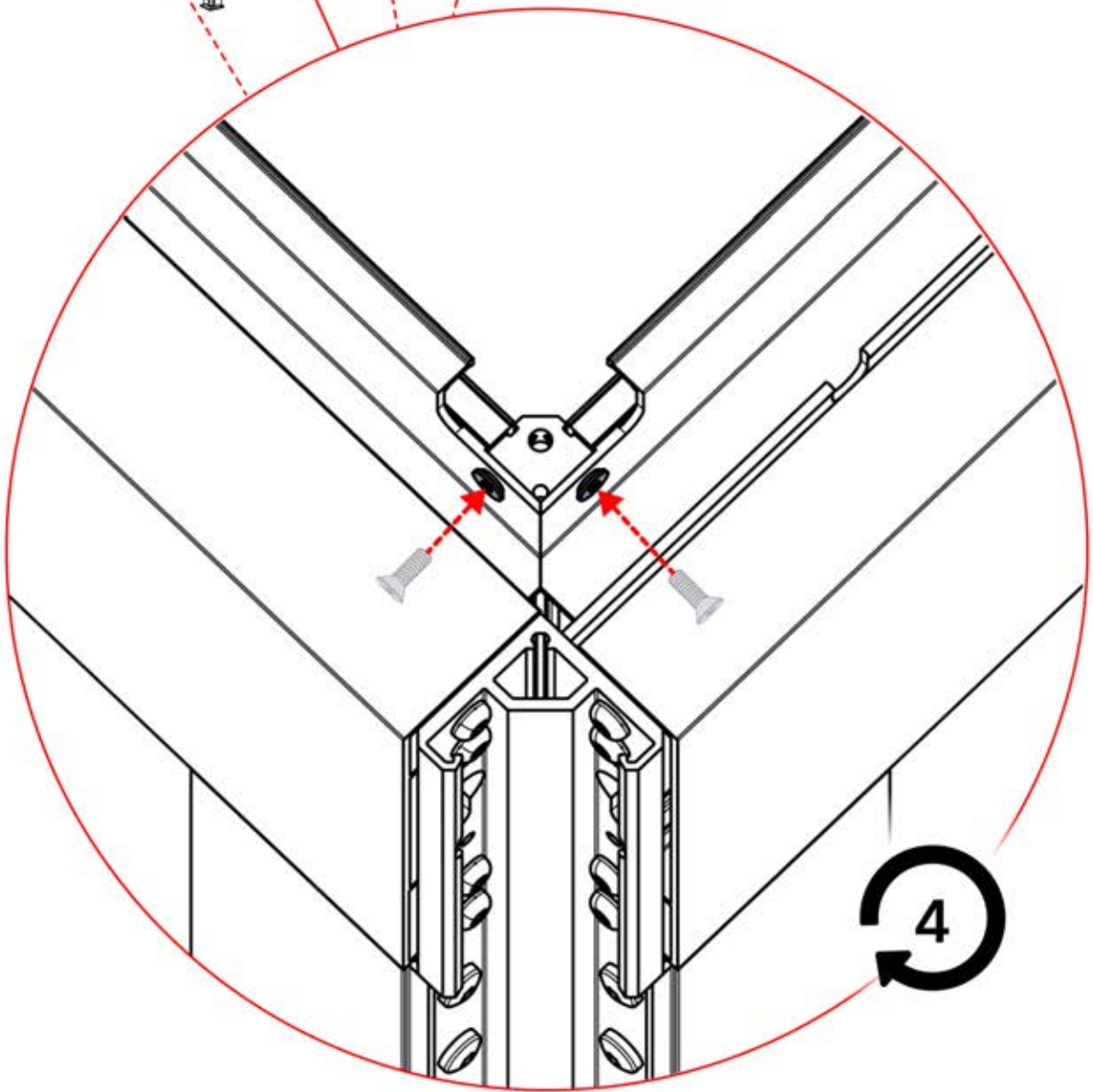
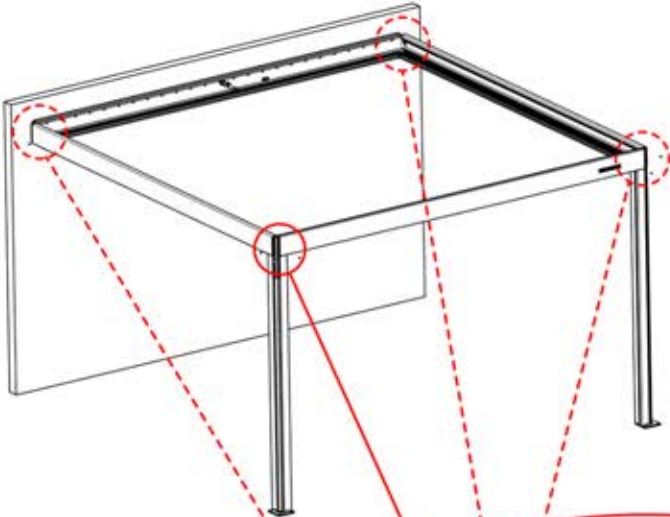

17

x7
PERGOLUX

4

ANTHRACITE: B245
BLANC: B253
NOIR: B249



PN-200000568
2x

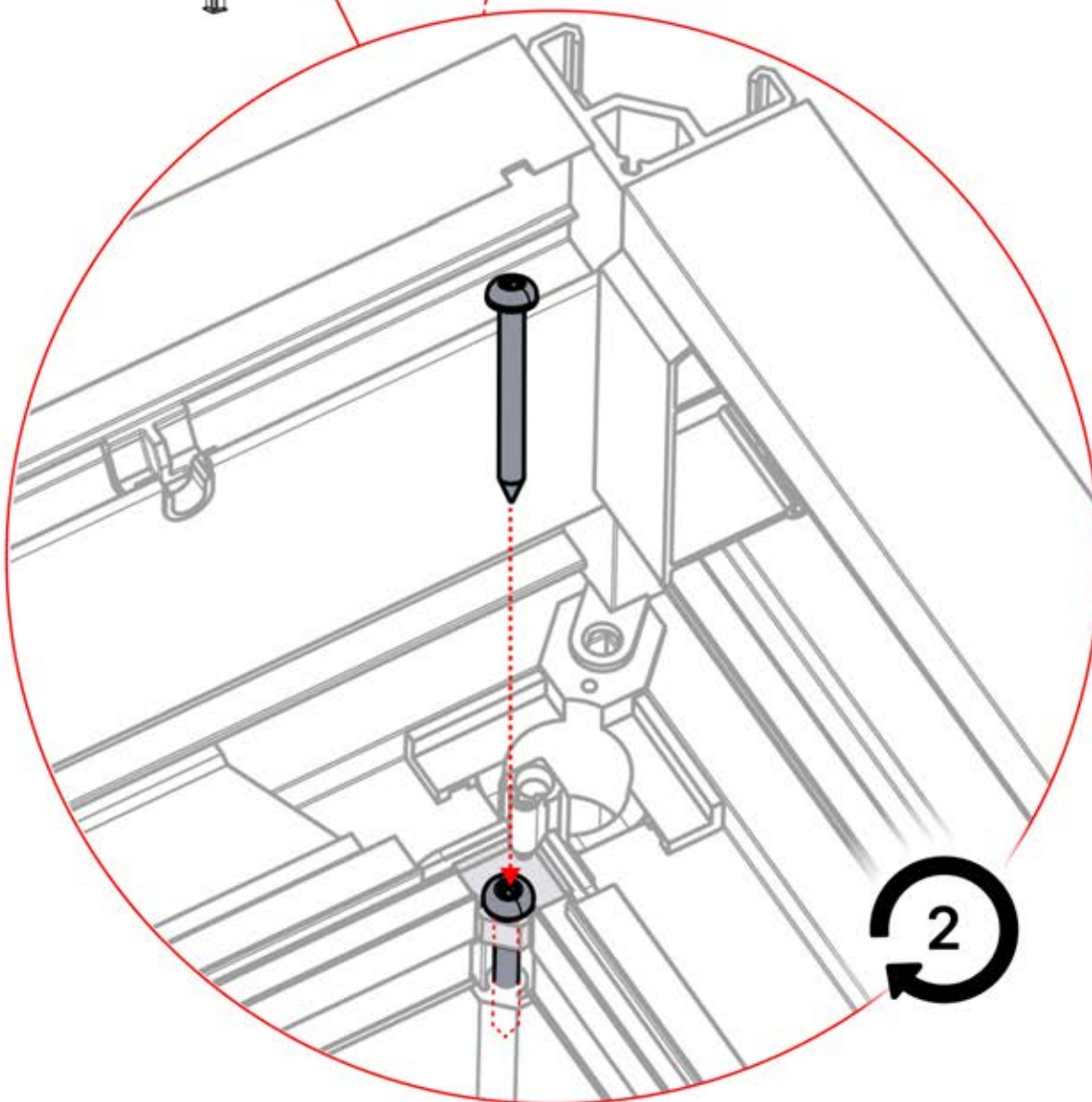
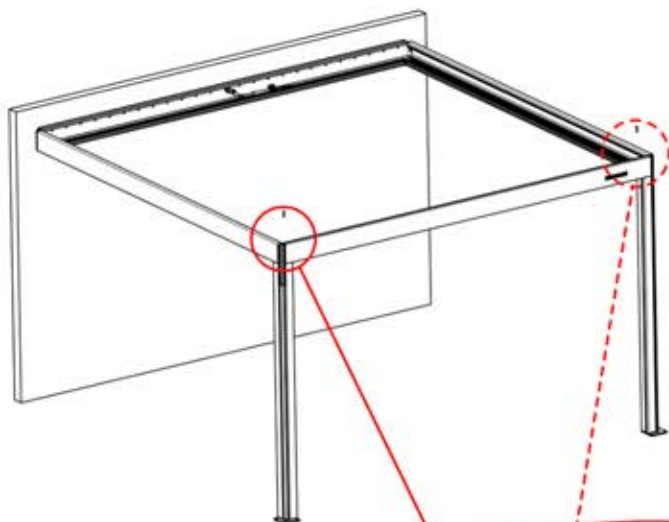

18



4

ANTHRACITE: B245
BLANC: B253
NOIR: B249

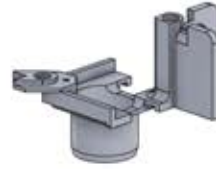

PN-200002617

2x

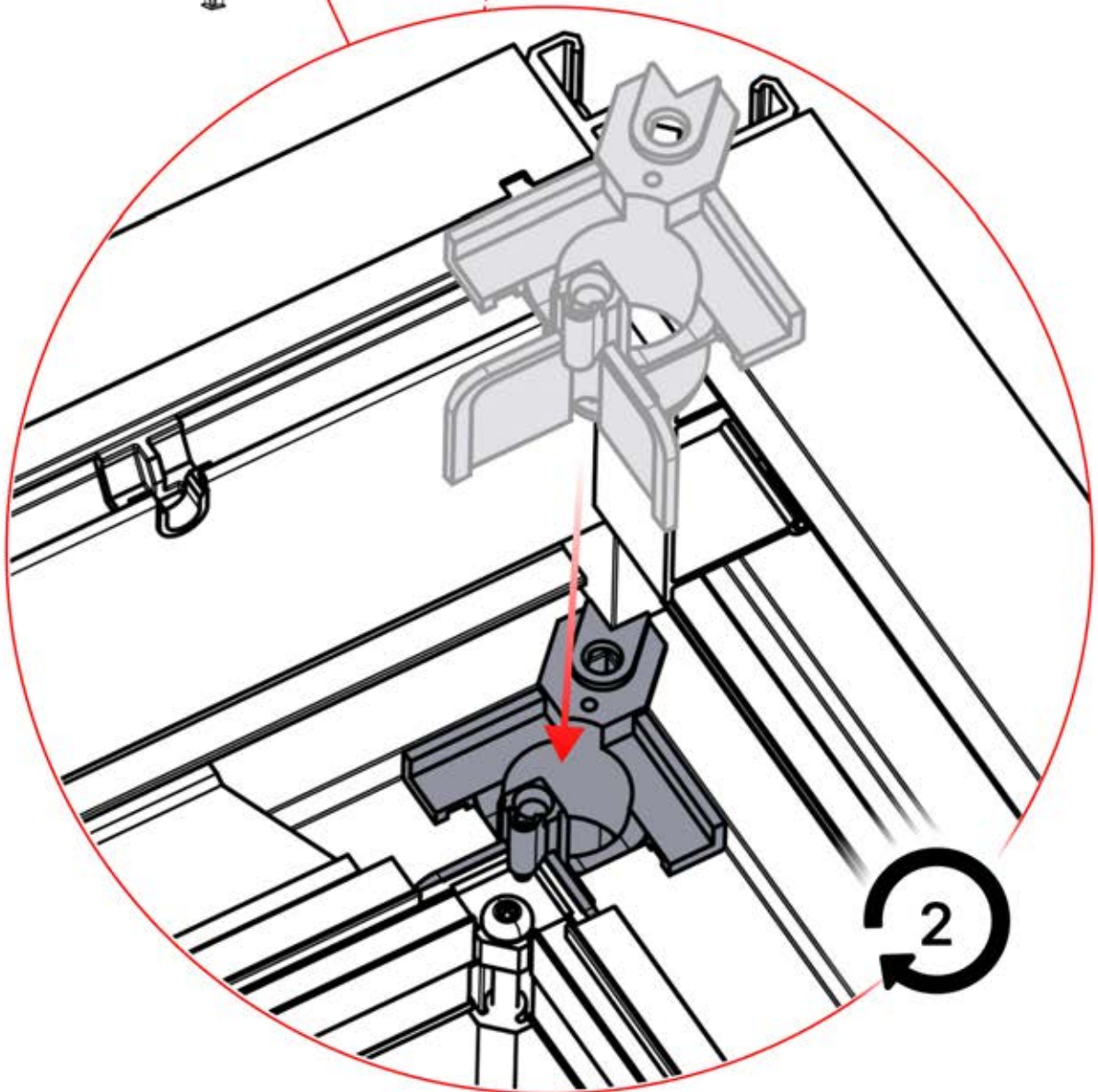
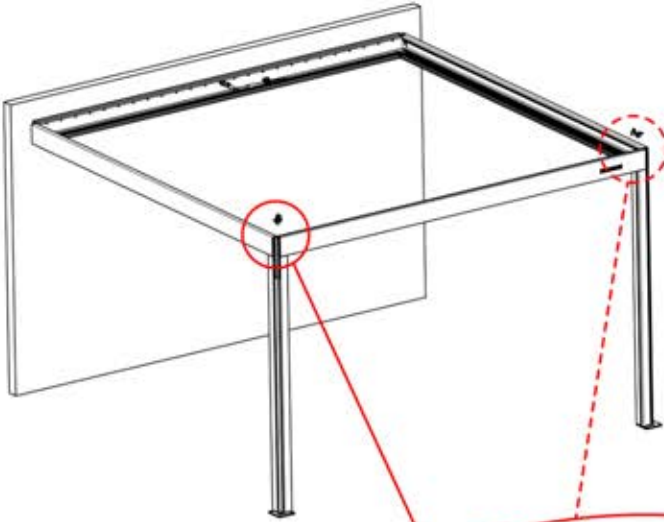

19

x1
FERGOLUX

4



ANTHRACITE: B245
BLANC: B253
NOIR: B249

PN-200002618
2x

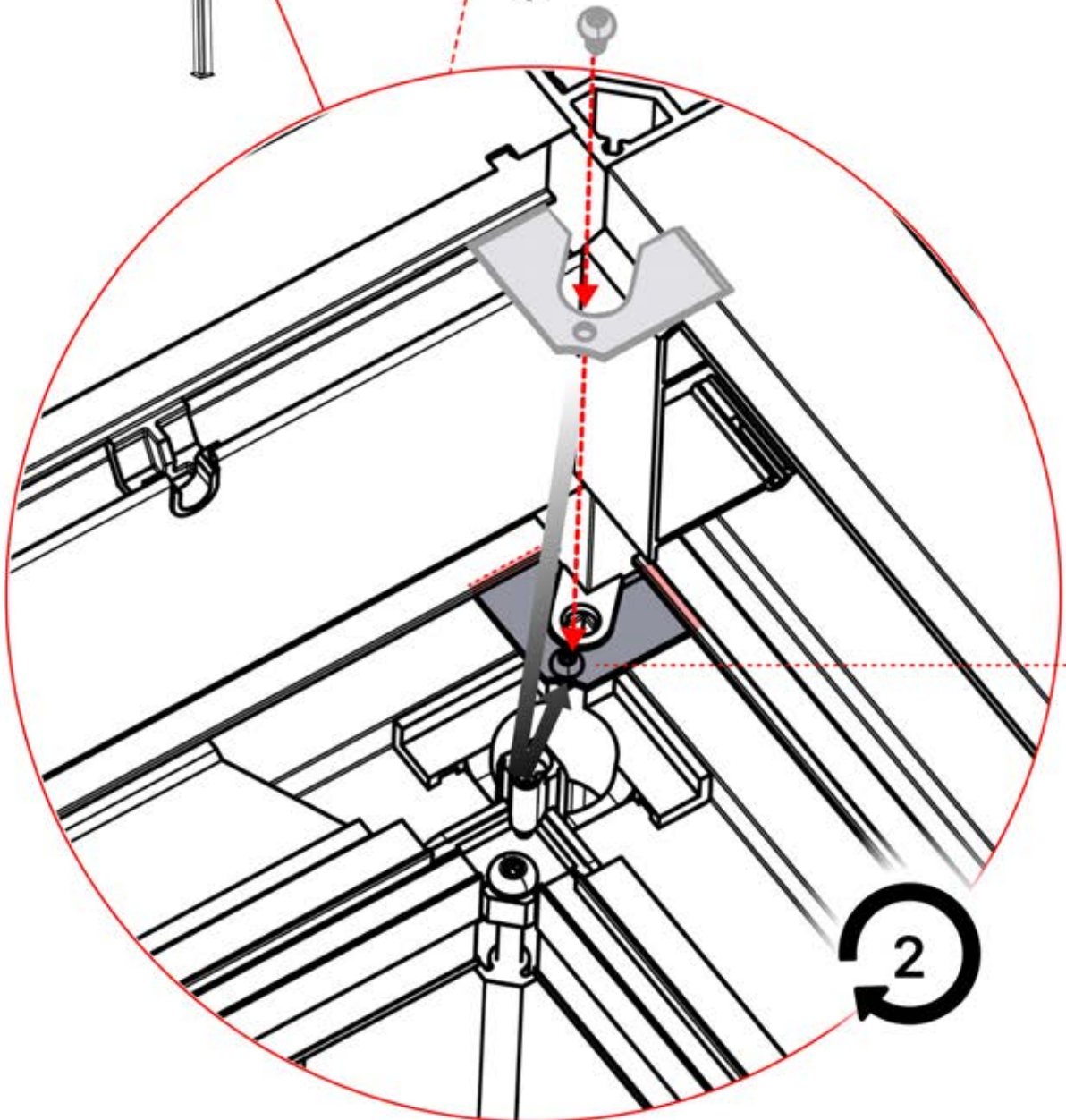
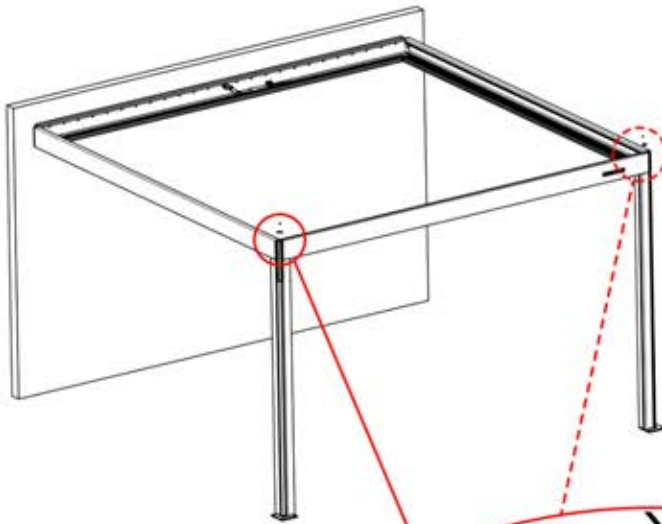

PN-200000571
2x

3.5x8
6 x 5/16"



20



4

ANTHRACITE: B245
BLANC: B253
NOIR: B249

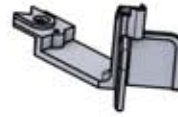

PN-200002792

2x

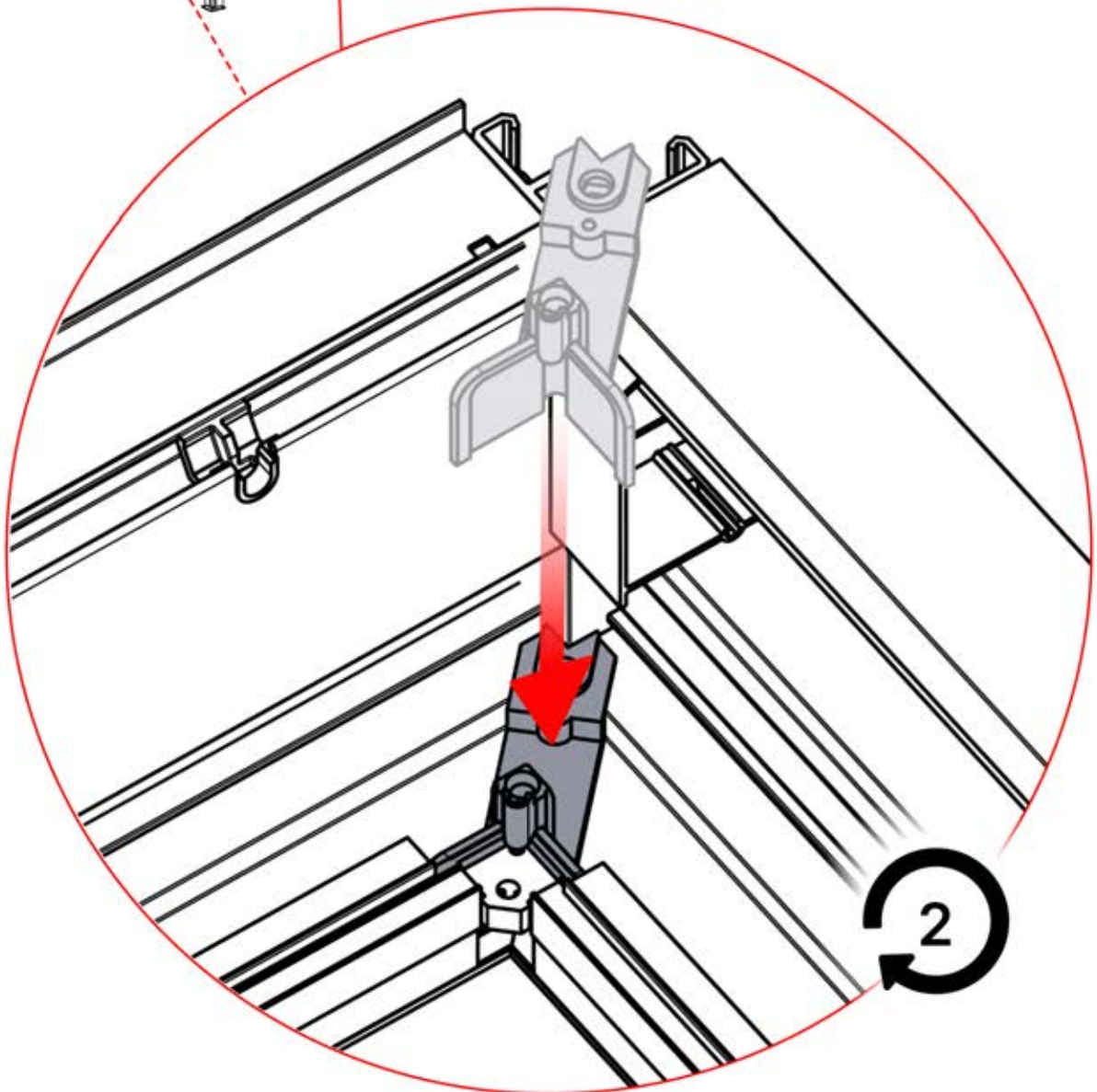
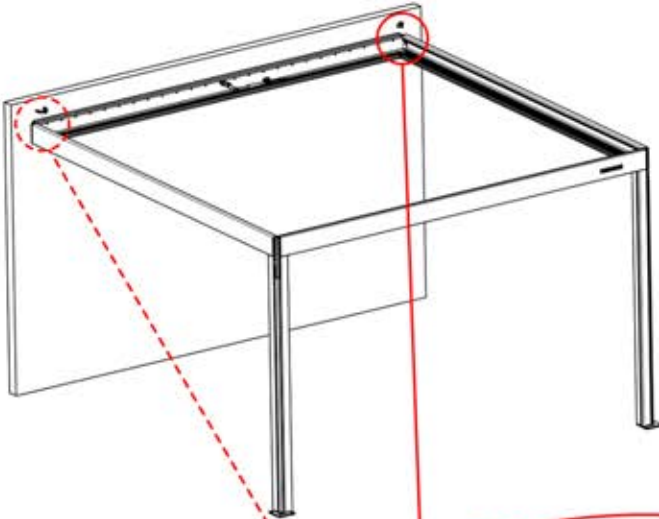

21

x7
PERGOLUX

4

ANTHRACITE: B245
BLANC: B253
NOIR: B249

PN-200002618
2x

PN-200000571
2x

3.5x8
6 x 5/16"

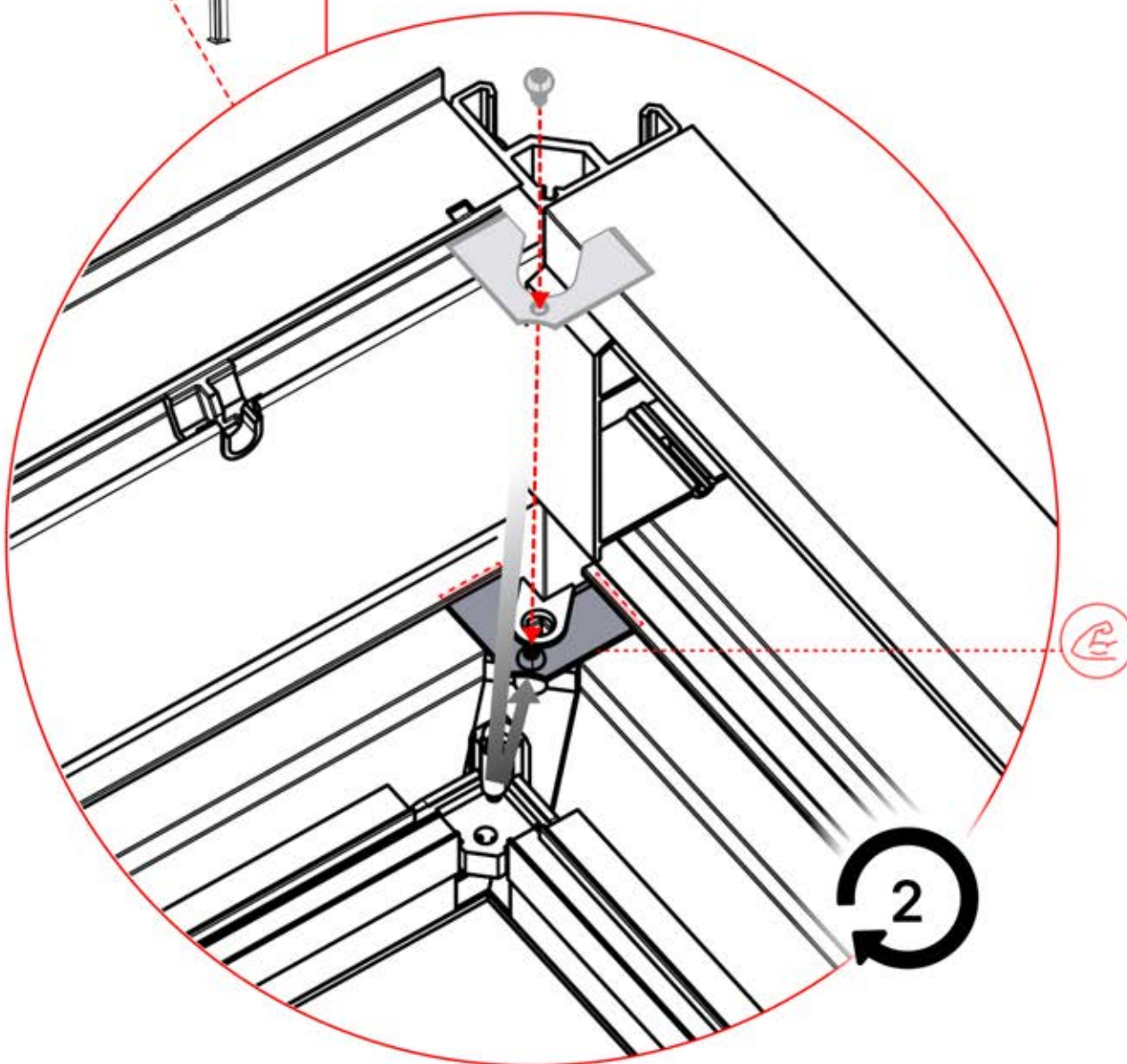
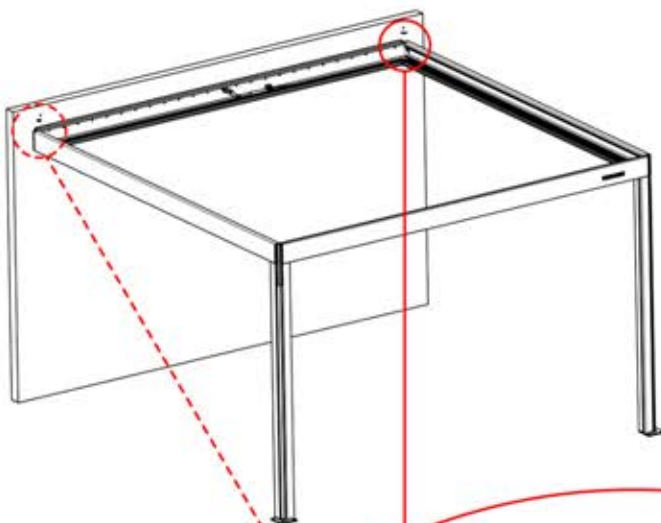

INFORMATION IMPORTANTE

Manipulez avec précaution.

Lors de l'installation des LEDs, ne tirez pas et ne pliez pas les fils des deux côtés, car cela pourrait entraîner le détachement des soudures. Utilisez un adhésif et un mastic de haute qualité, résistants aux intempéries et à la moisissure, pour sceller les angles de la pergola et éviter toute infiltration. Optez pour des produits conçus pour une utilisation en extérieur et offrant une adhérence solide et durable.

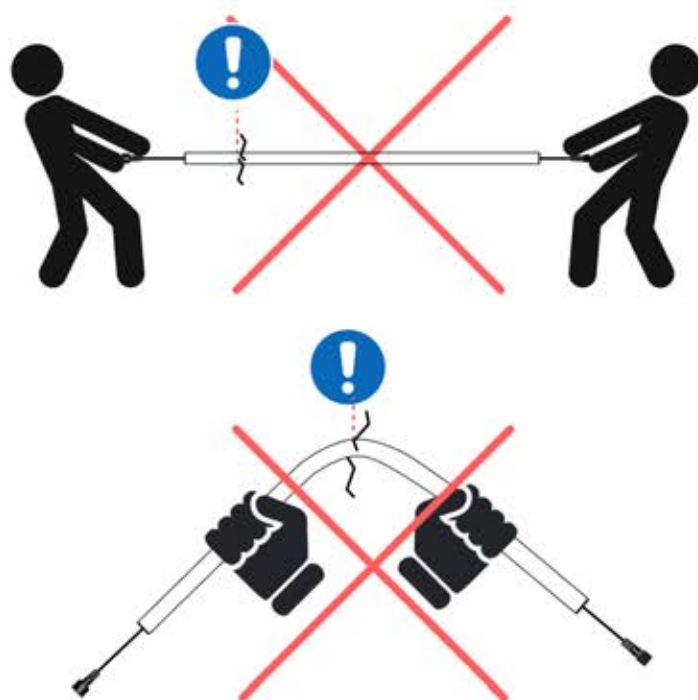

Important ! Veuillez regarder toutes les vidéos avant de commencer le montage.

Ces vidéos contiennent des informations importantes concernant le processus de montage.

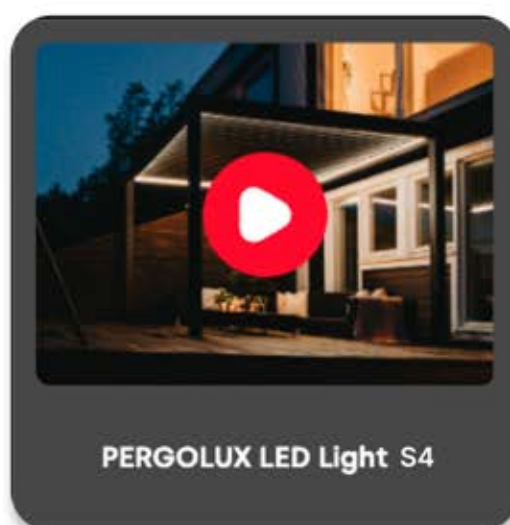

INFORMATION IMPORTANTE

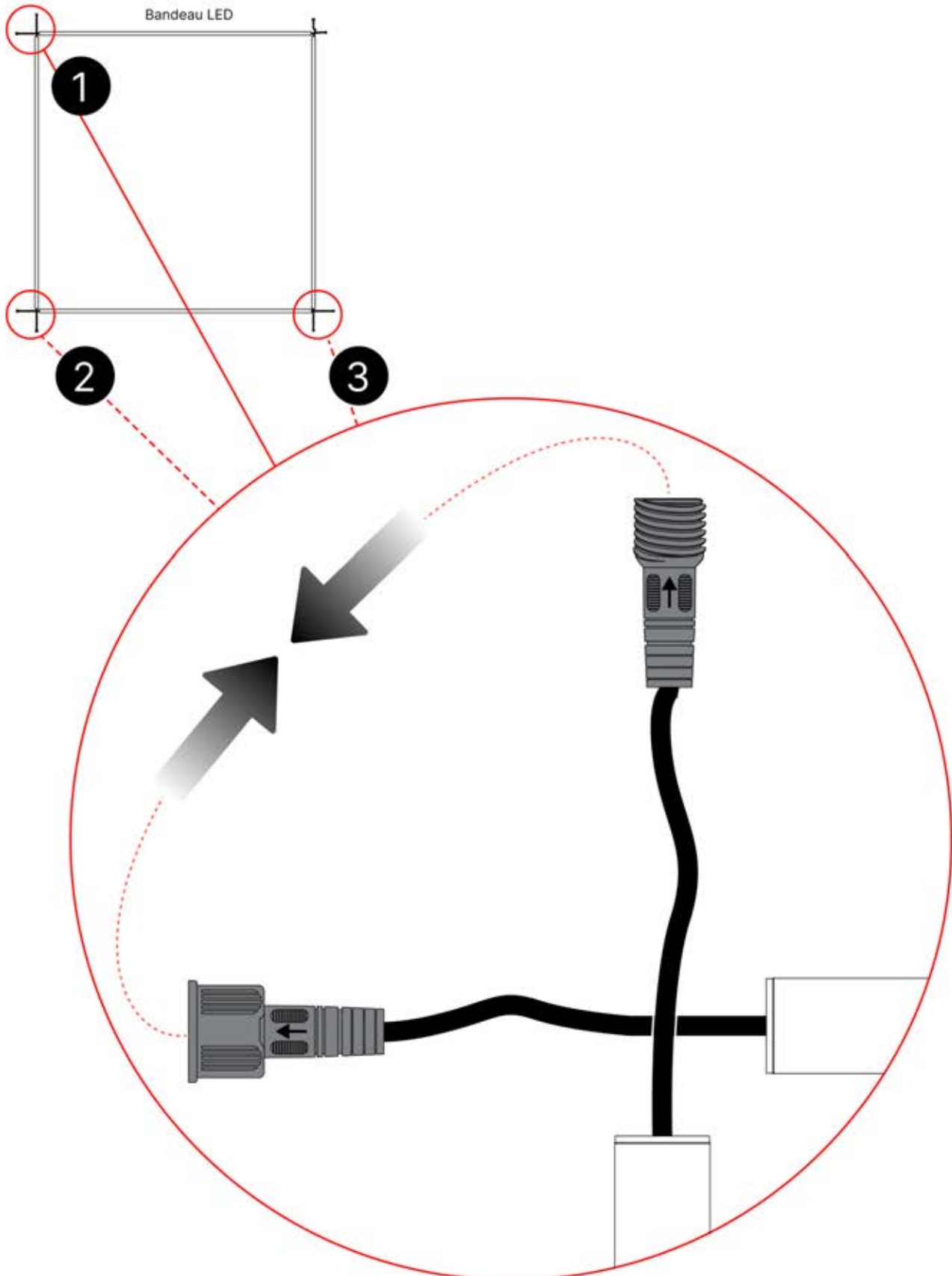

INFORMATION

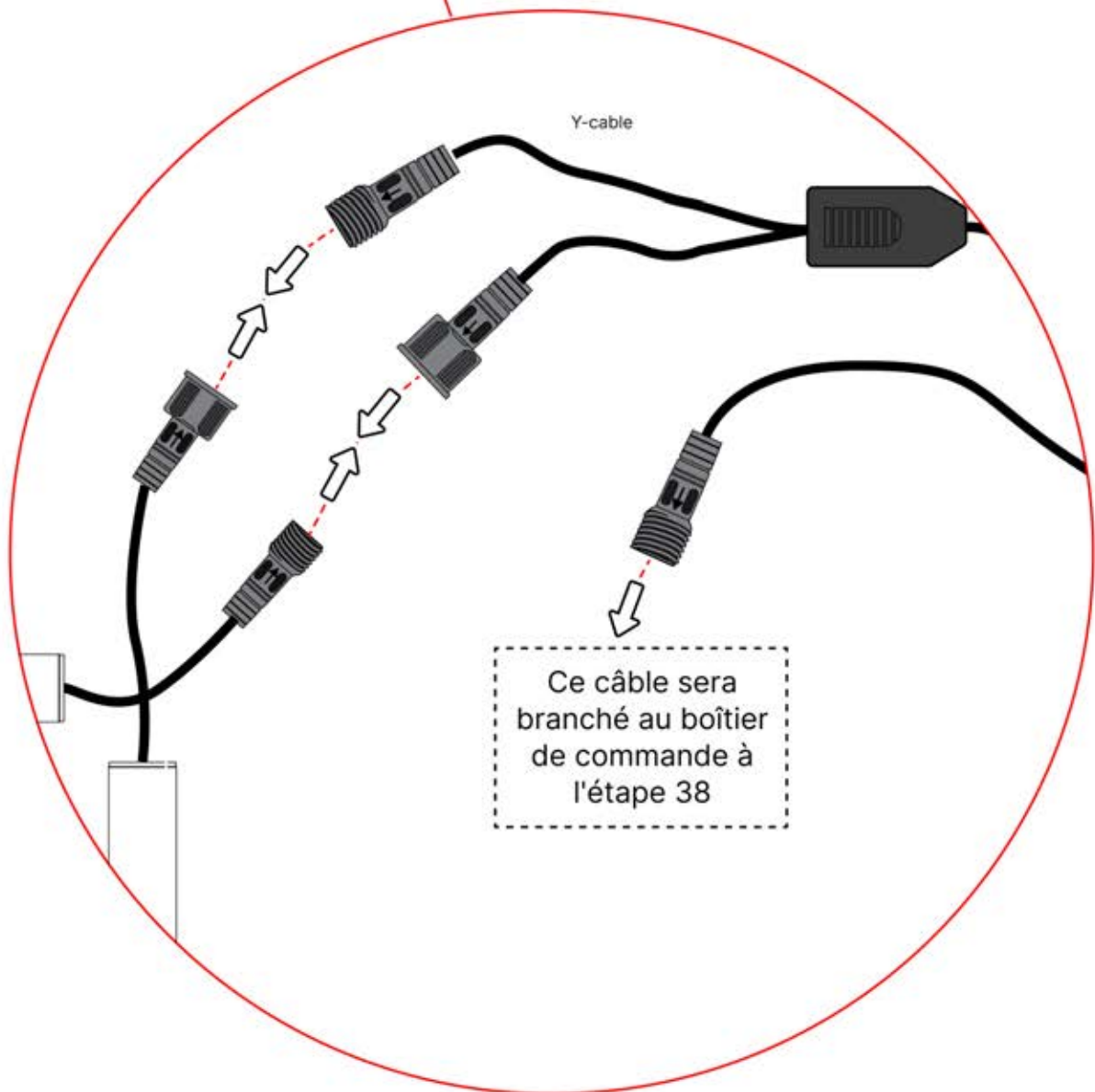
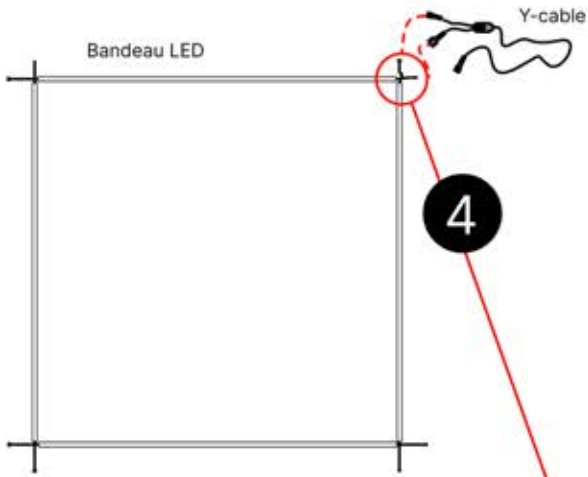

22

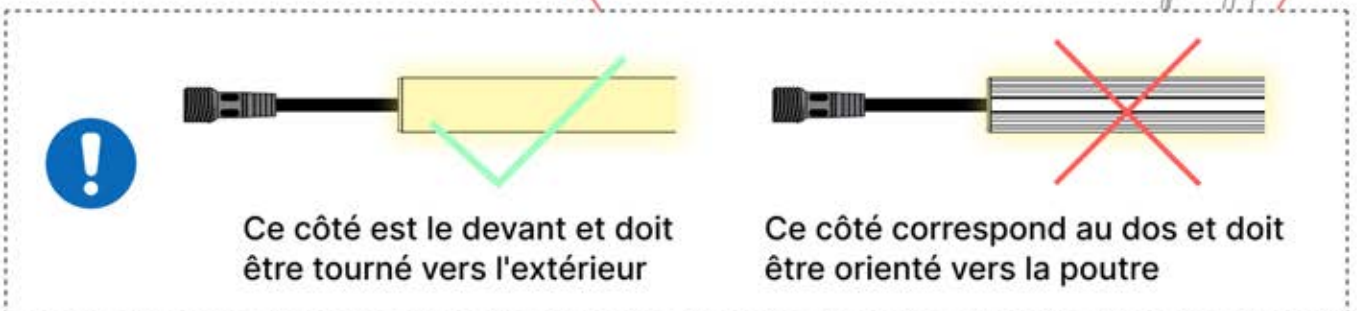
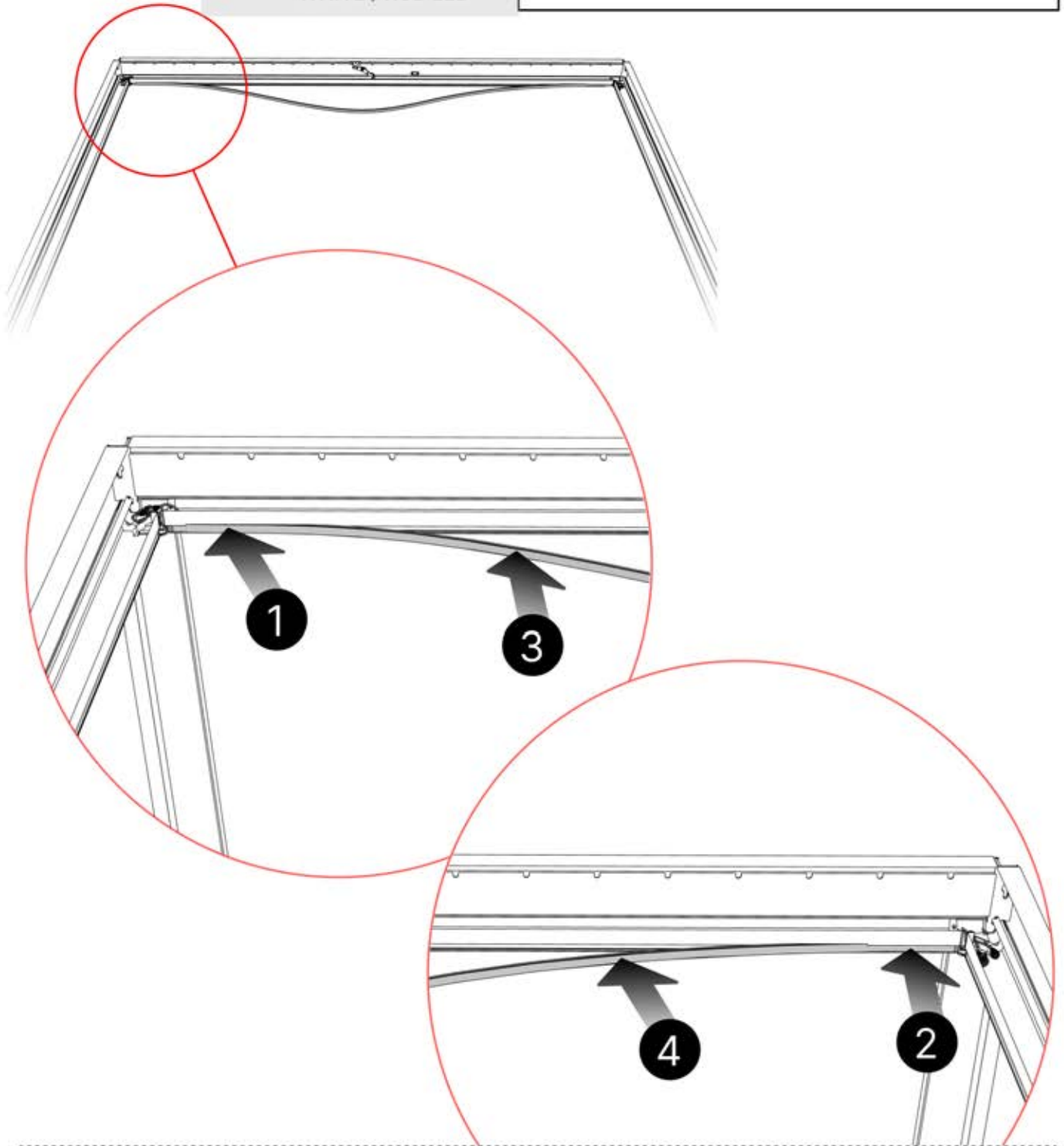
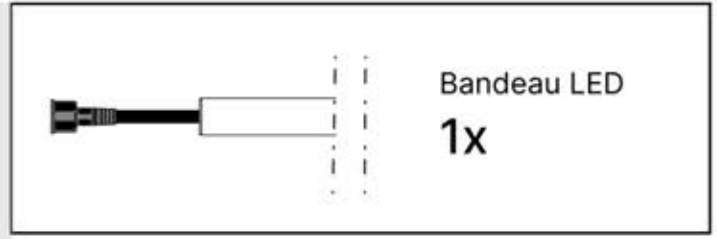
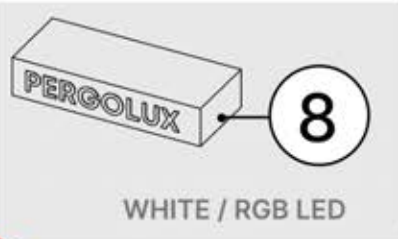

23



Conseil : pour faciliter l'installation des LED, vaporisez de l'eau savonneuse sur le rail avant de procéder au montage.

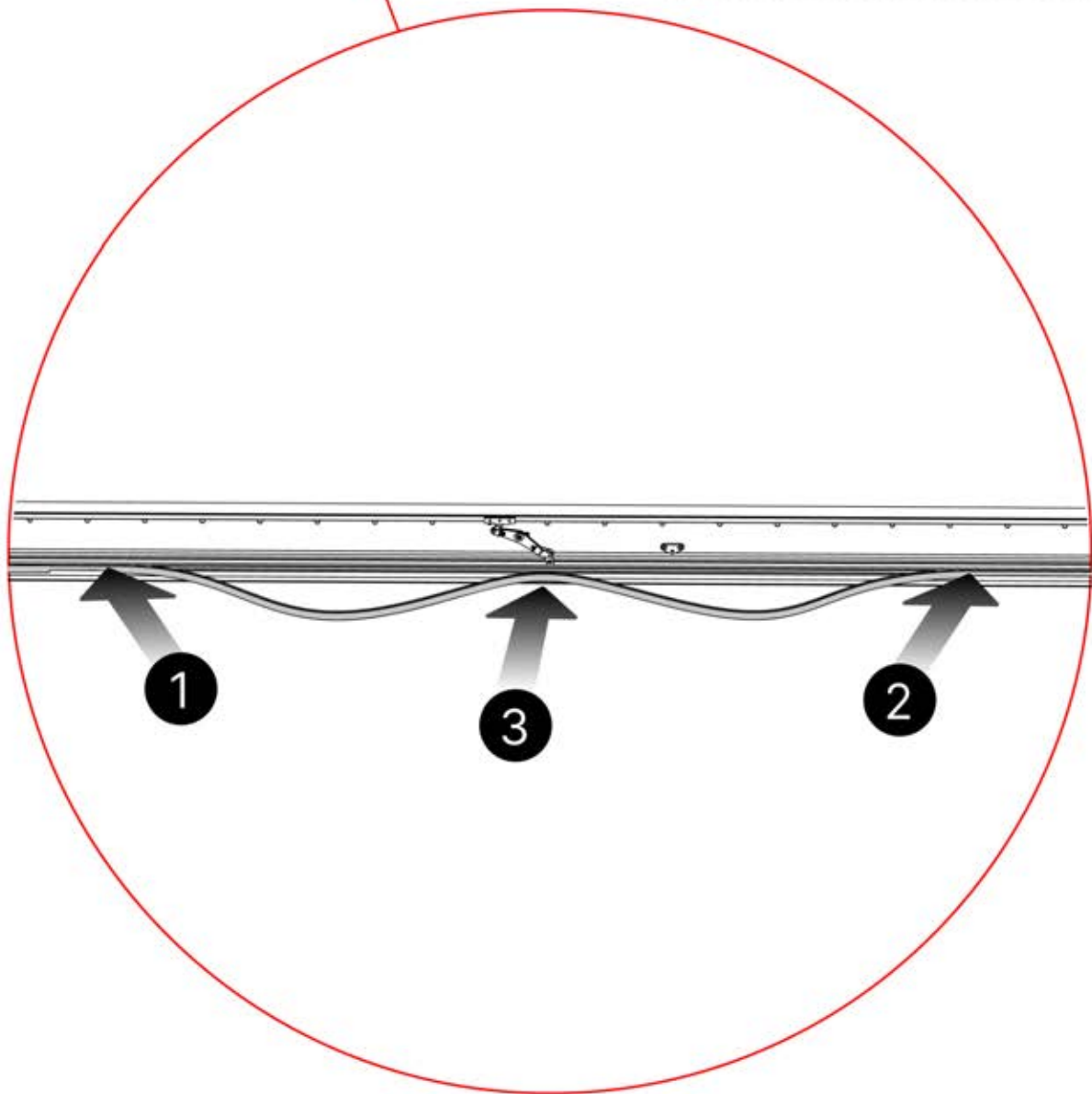
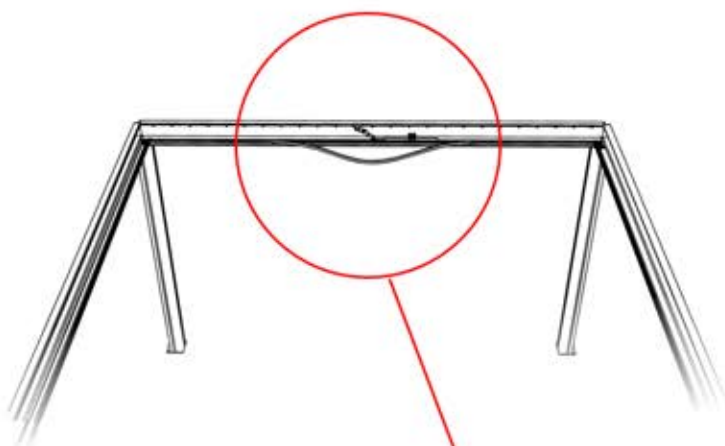

24

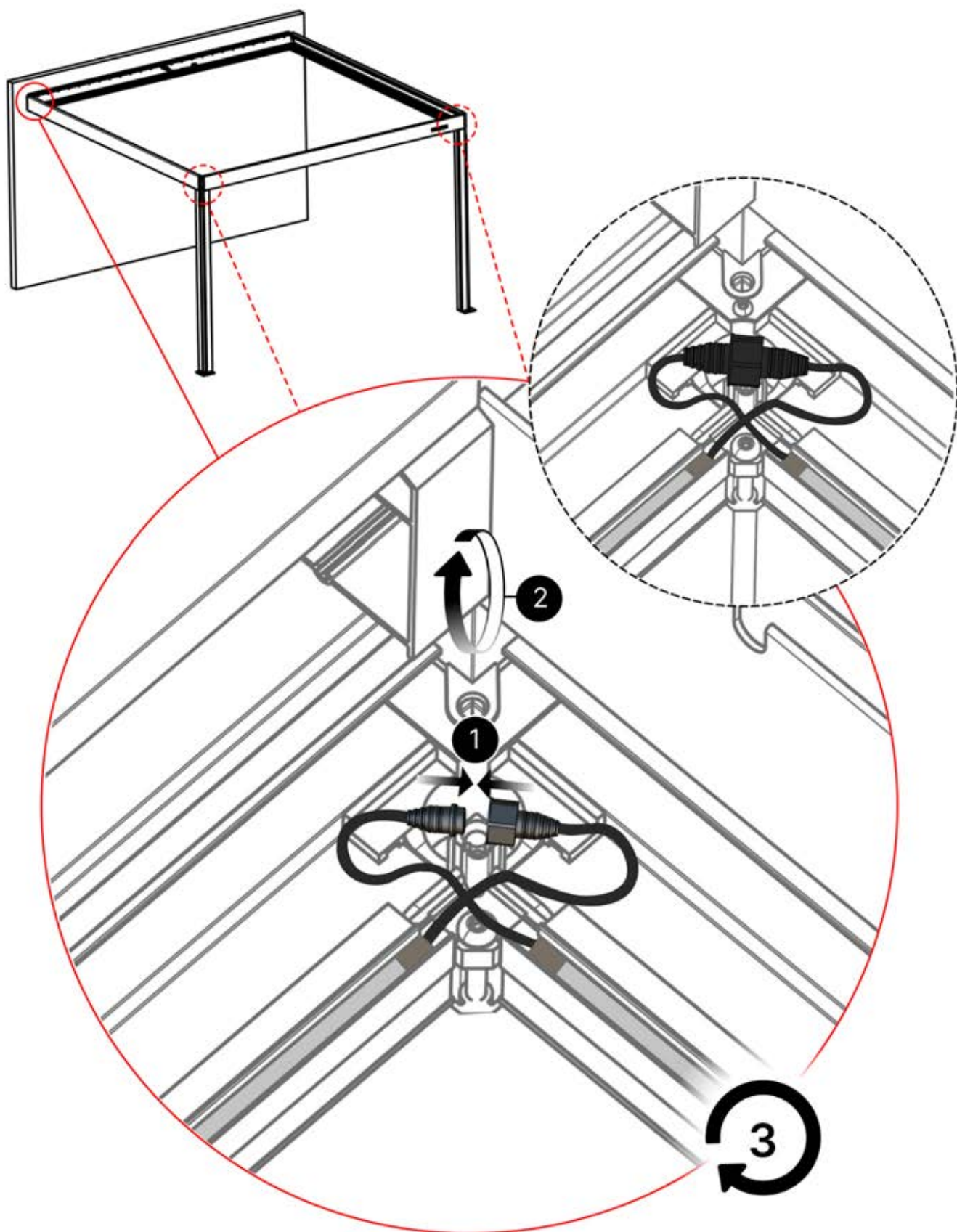

25

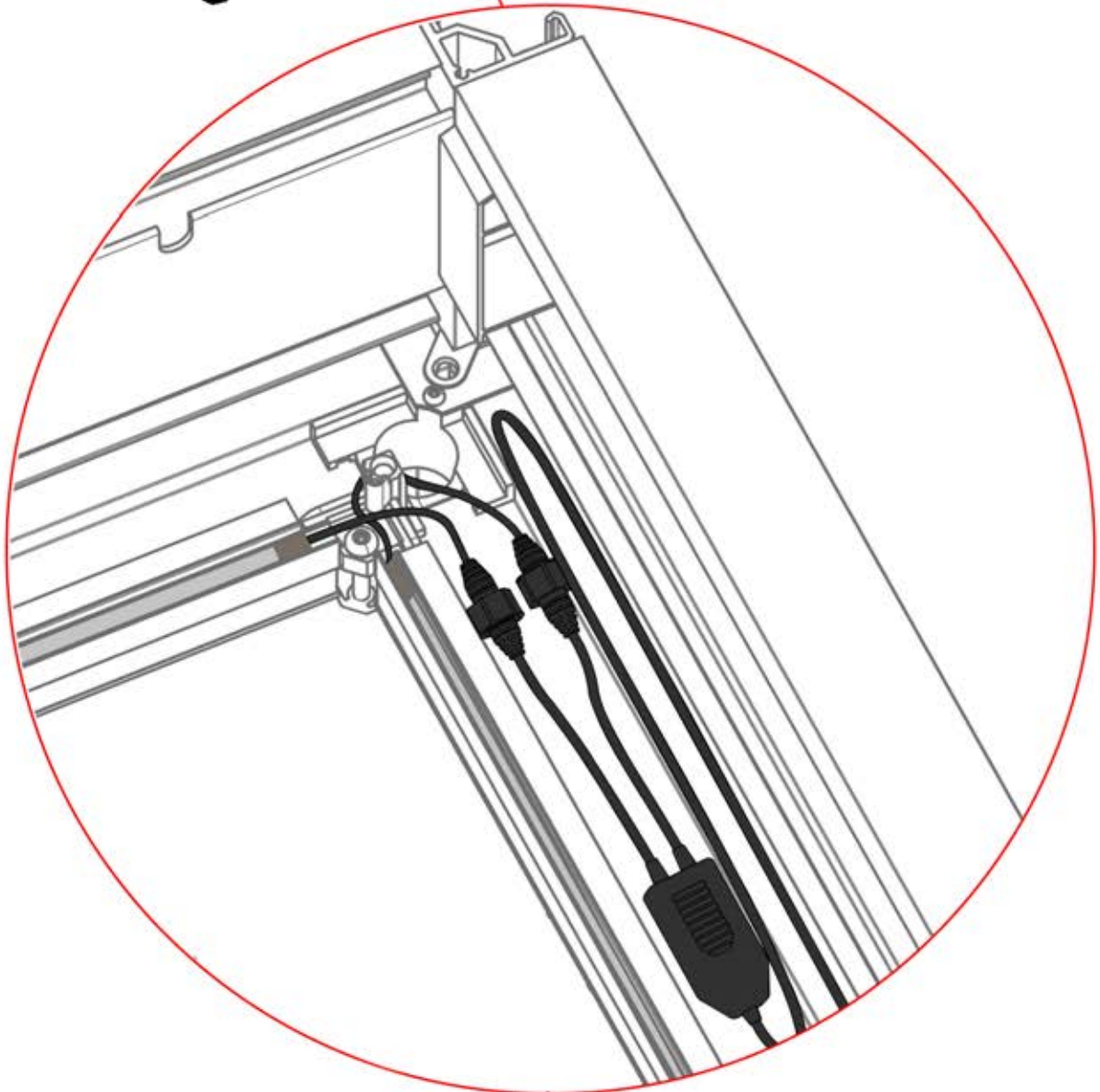
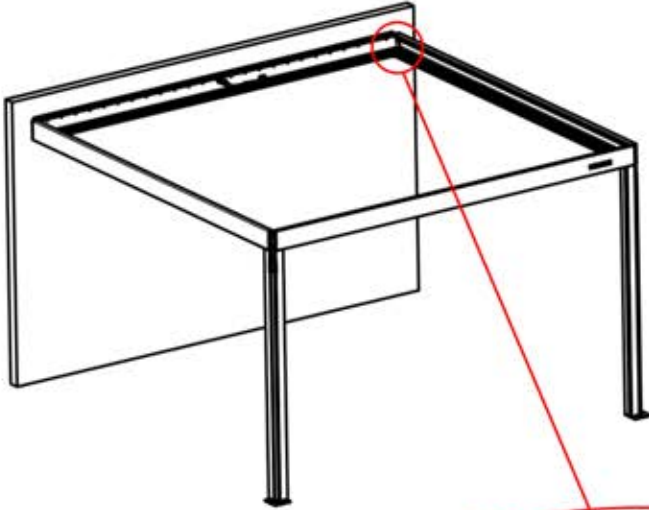
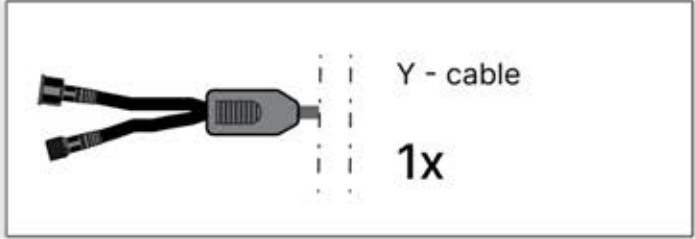
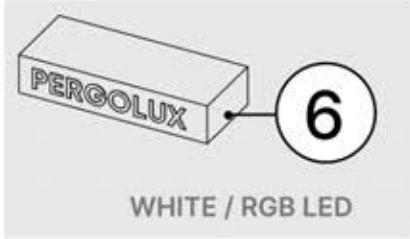

26



4

ANTHRACITE: B245
BLANC: B253
NOIR: B249



PN-200000516
2x

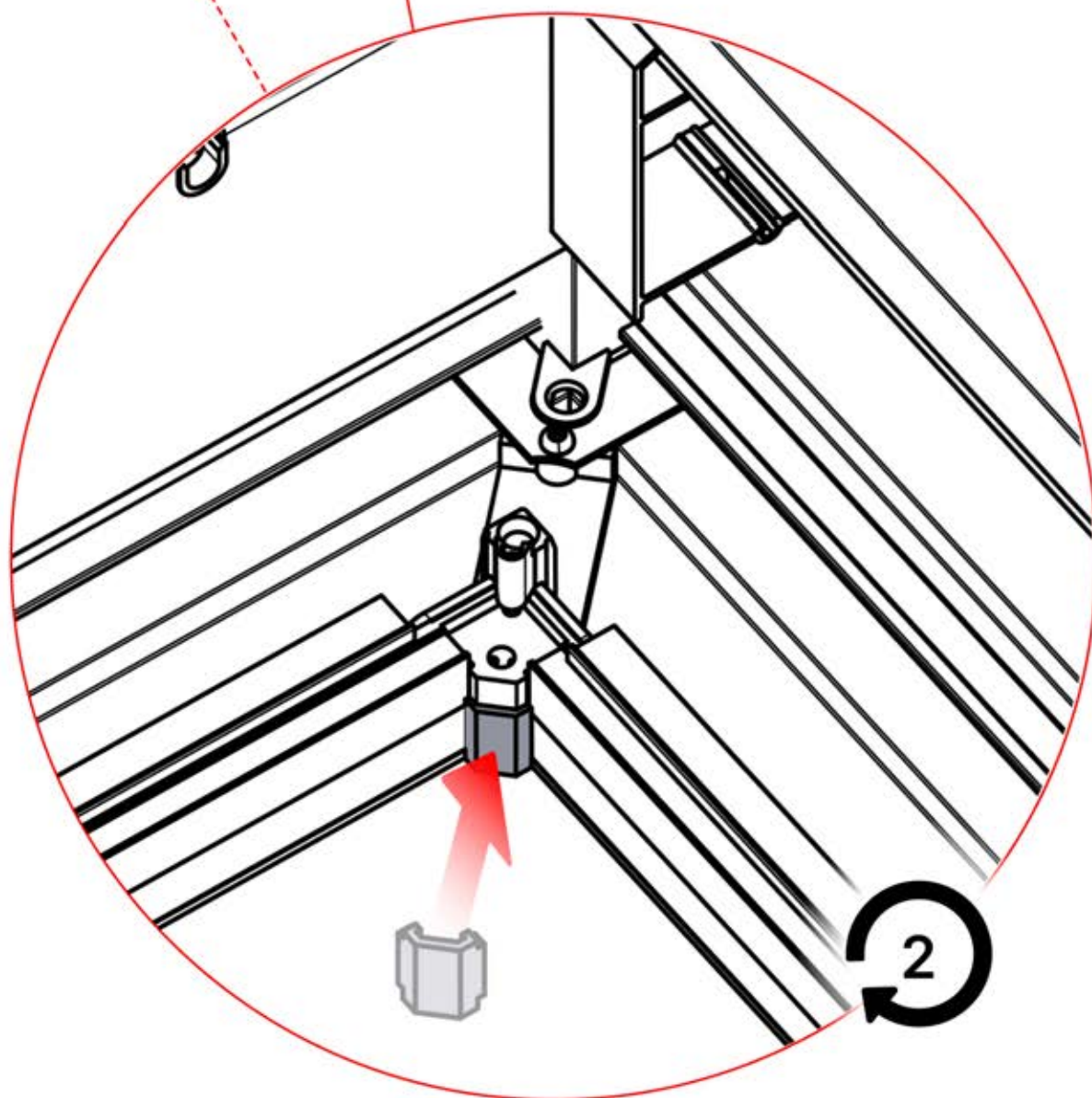
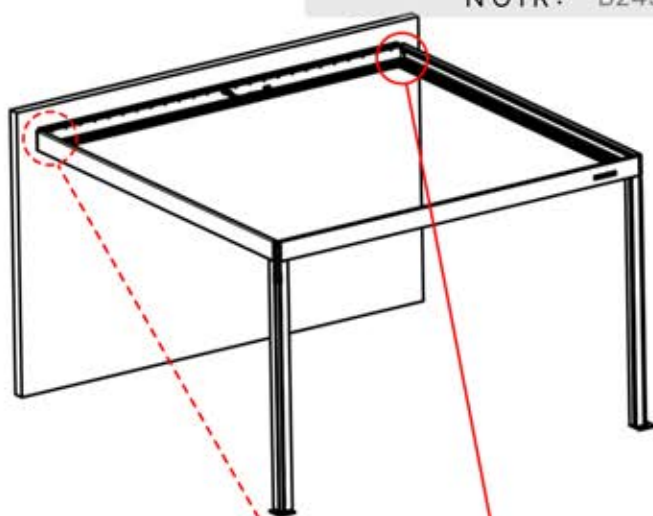

27



4

ANTHRACITE: B245
BLANC: B253
NOIR: B249



PN-200002625

4x



PN-200000960

4x

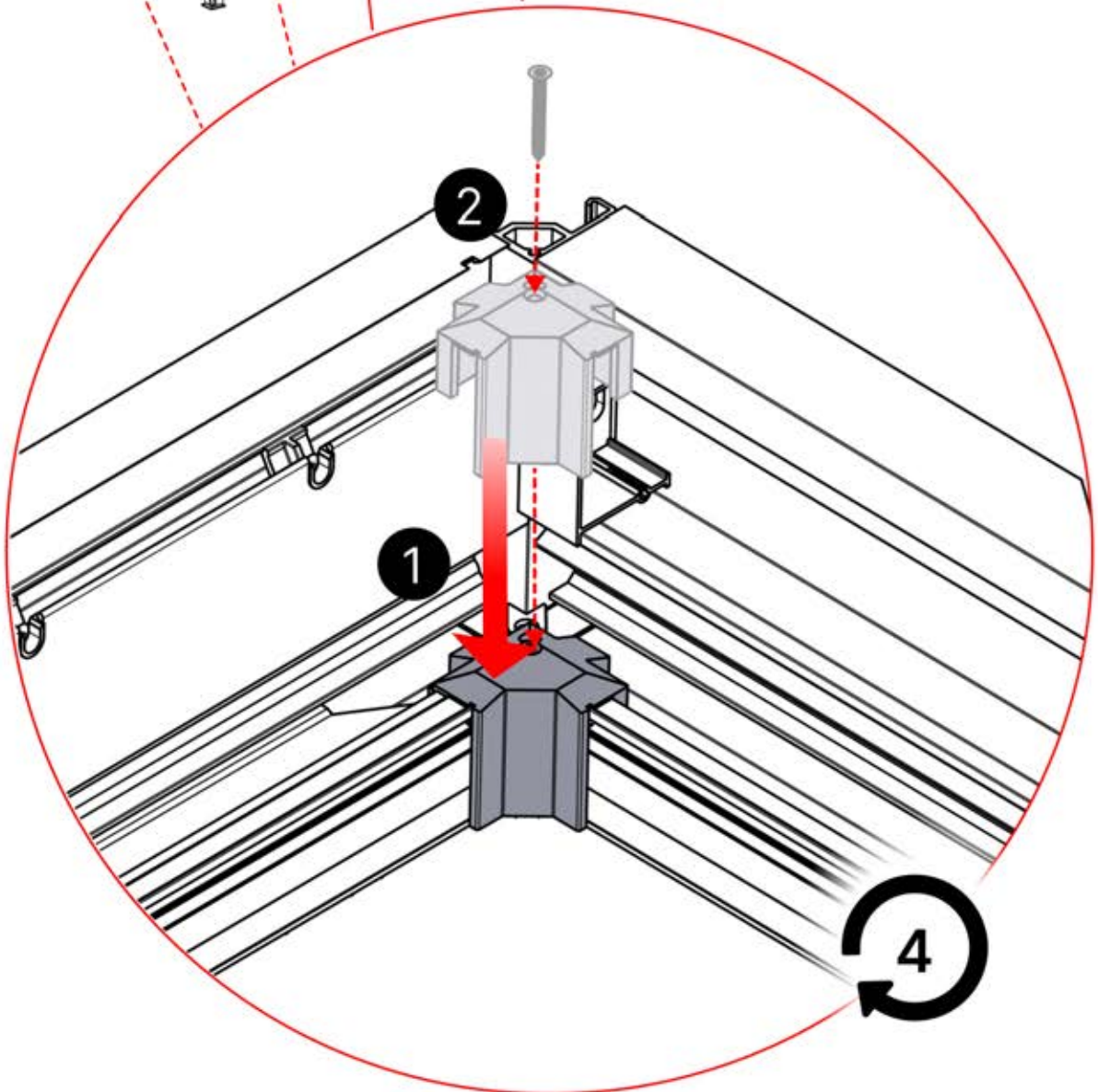
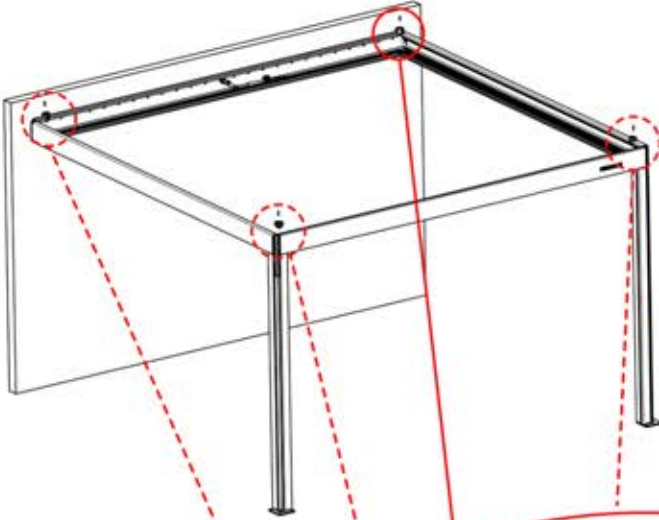

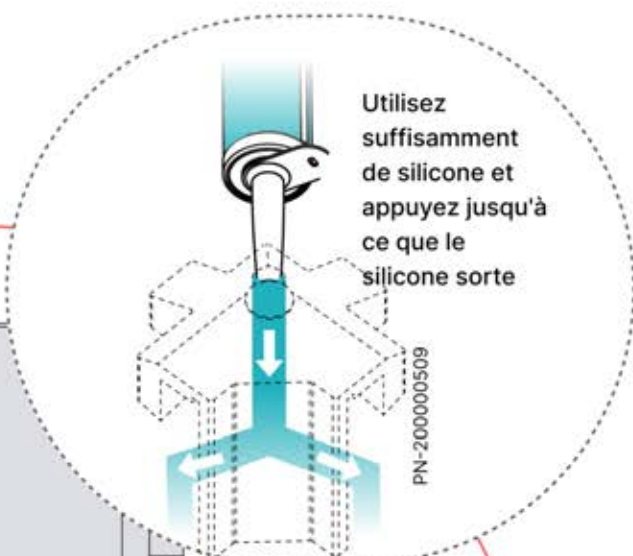
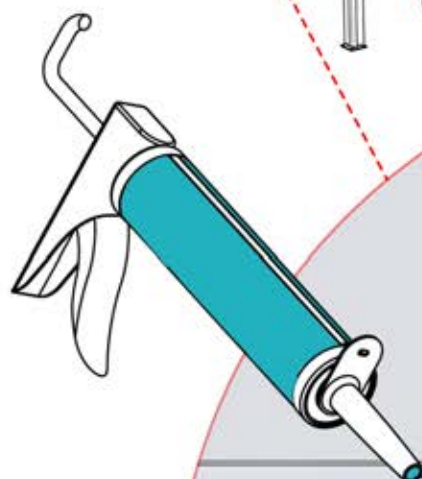
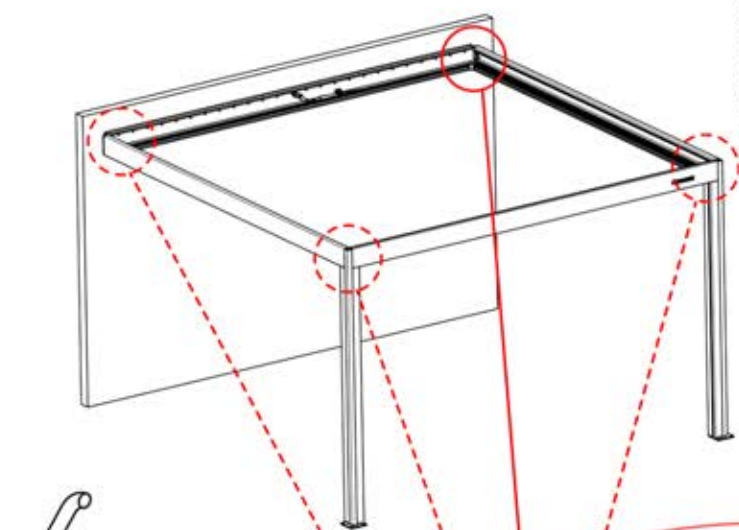

Utilisez suffisamment de silicone et appuyez jusqu'à ce que le silicone sorte

PN-200000509

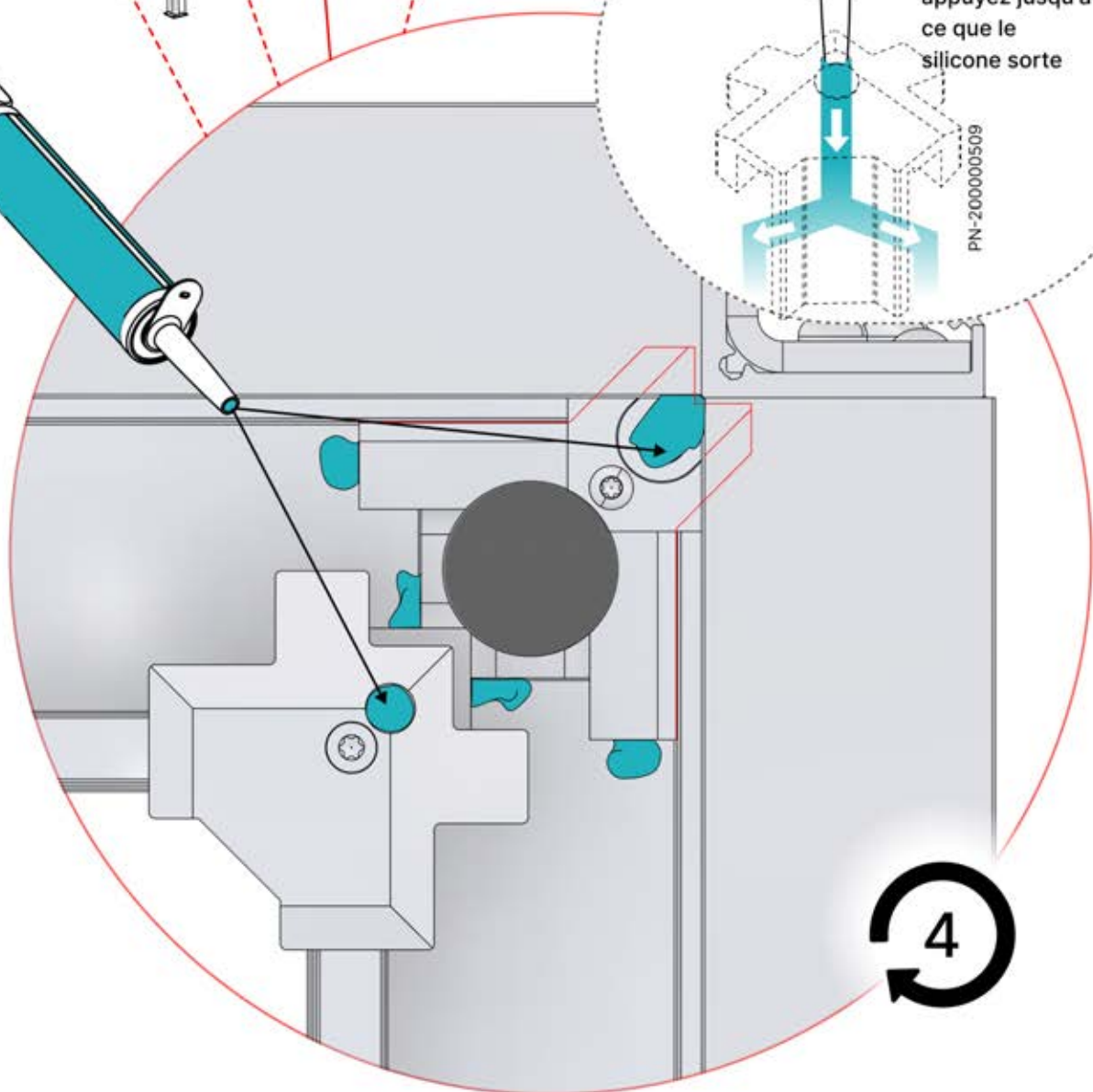

29

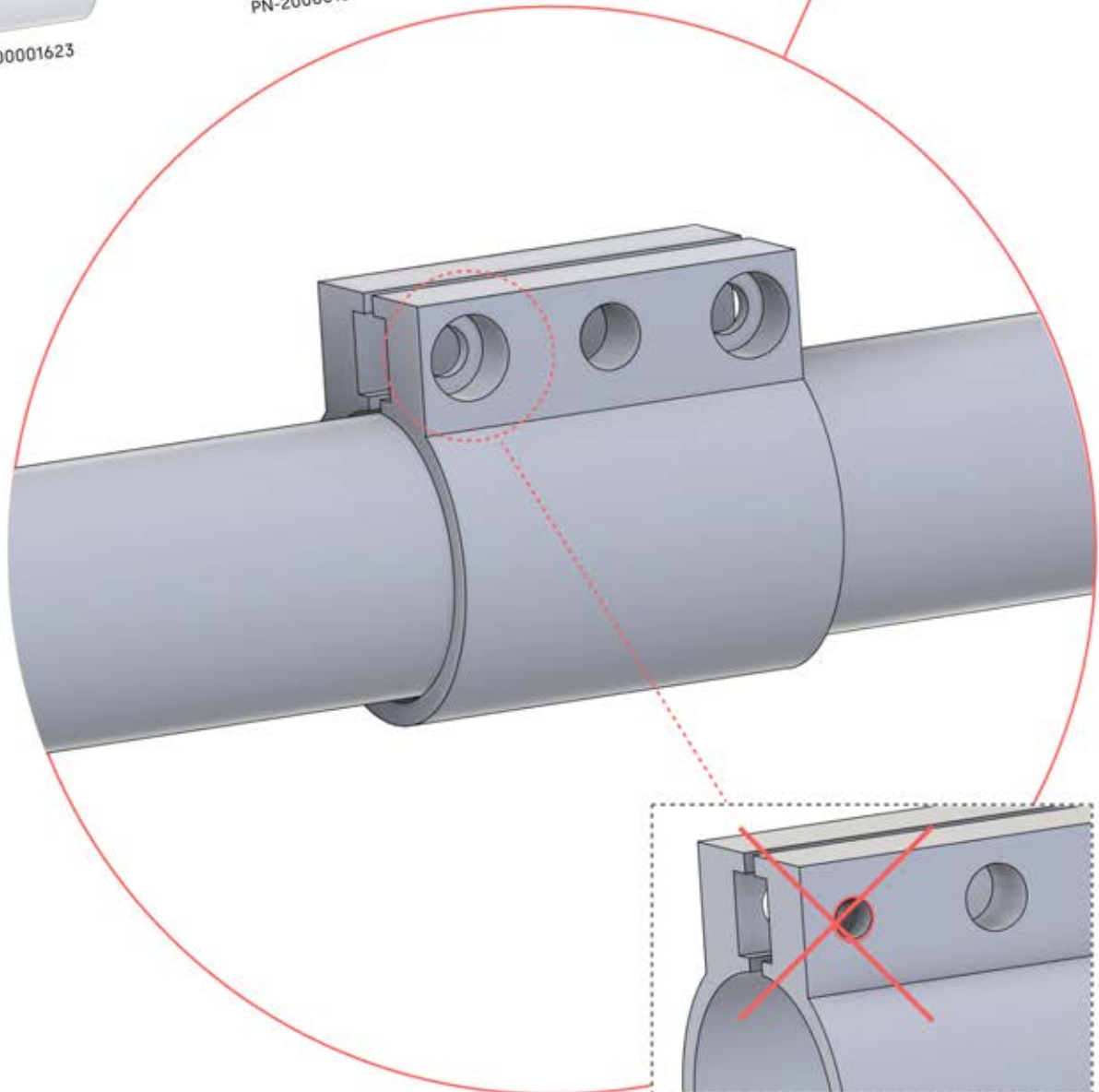
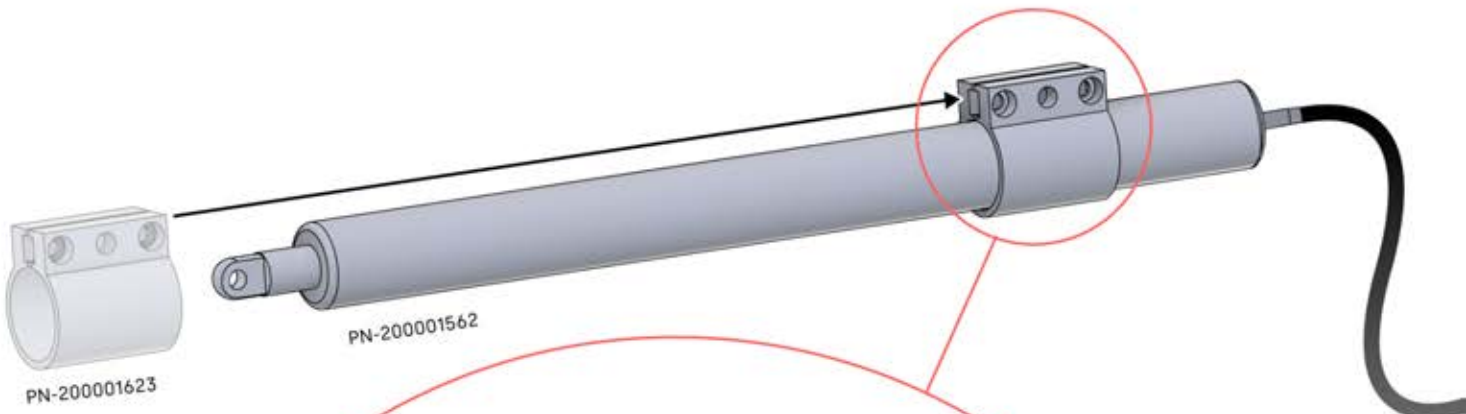
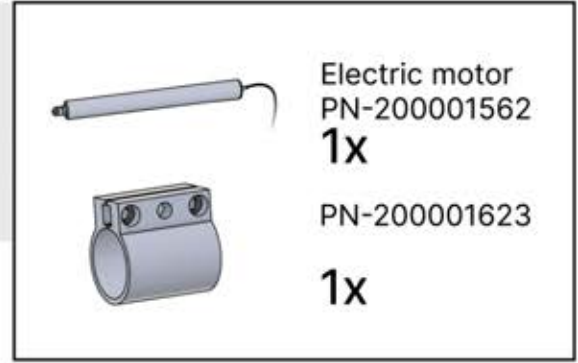
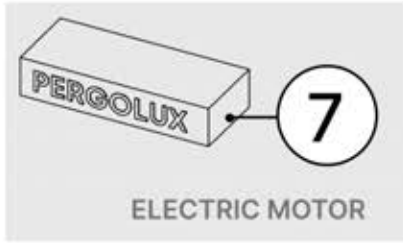

30

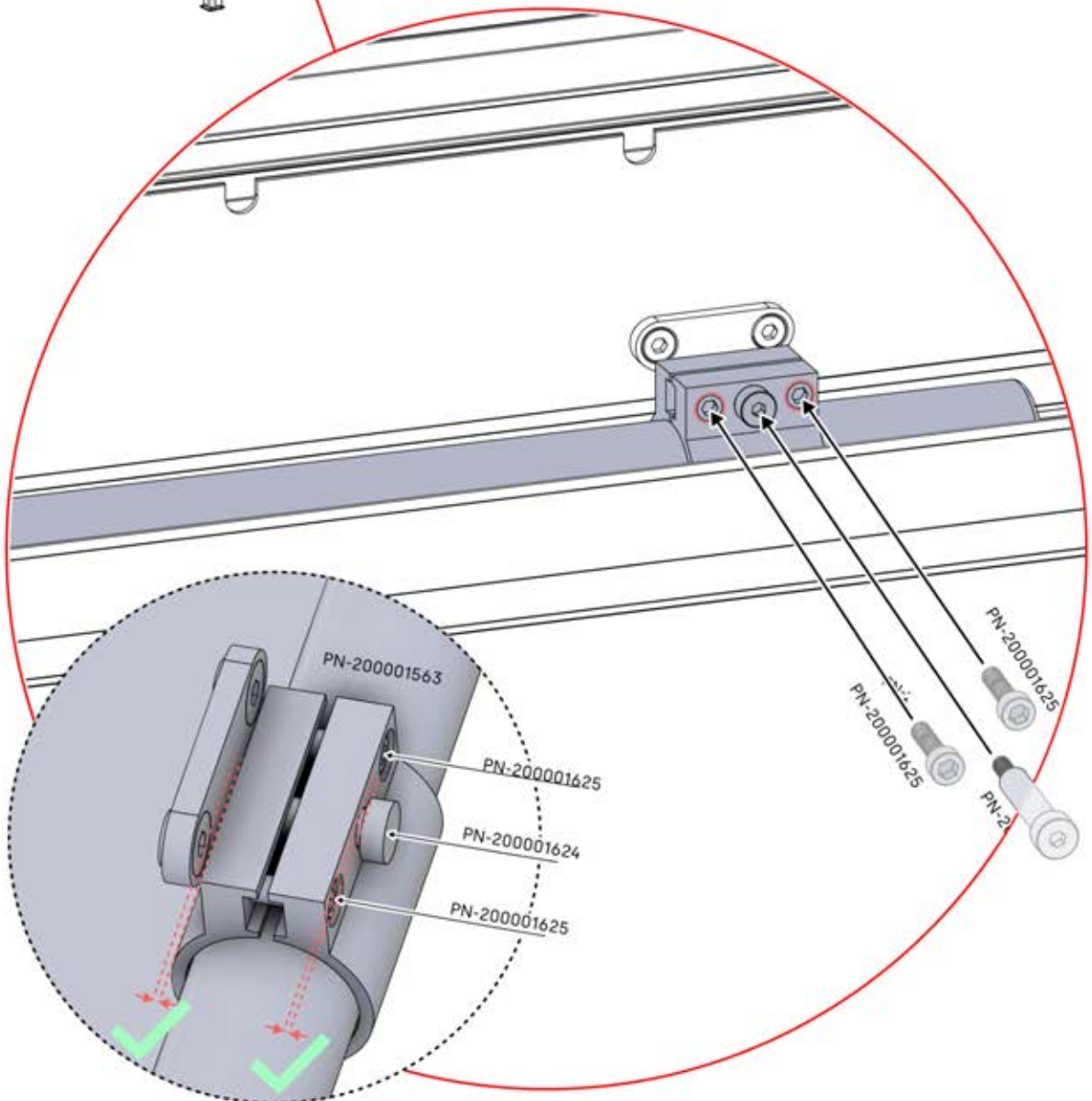
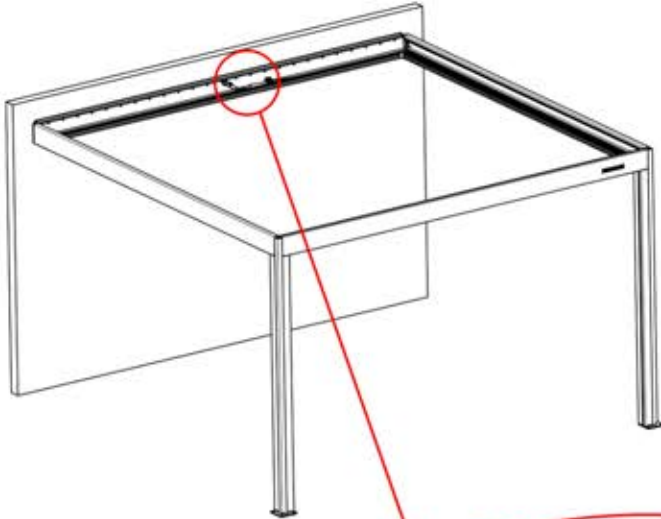
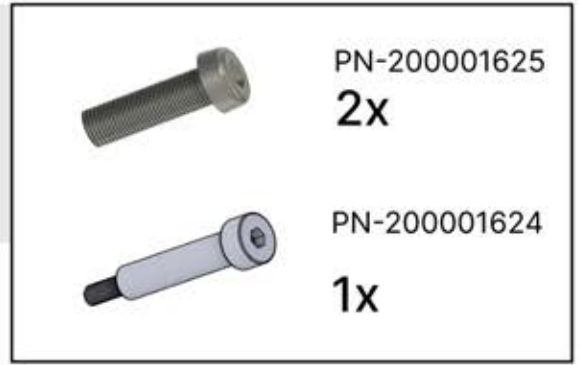
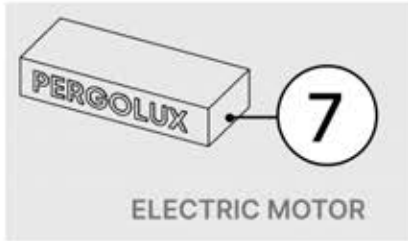

31

x1
FERGOLUX

4

ANTHRACITE: B233
BLANC: B241
NOIR: B237

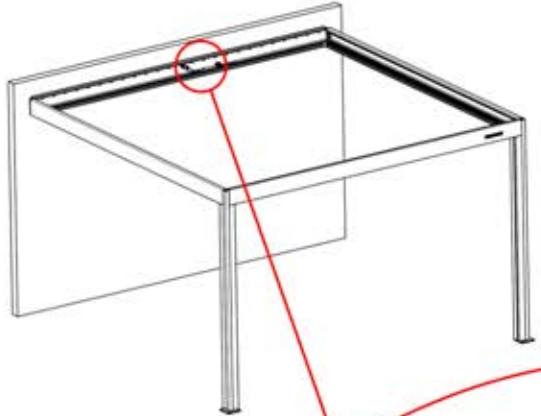

PN-200003372
1x

PN-20000502
1x

PN-200003373
1x

PN-20000561
1x

8x25

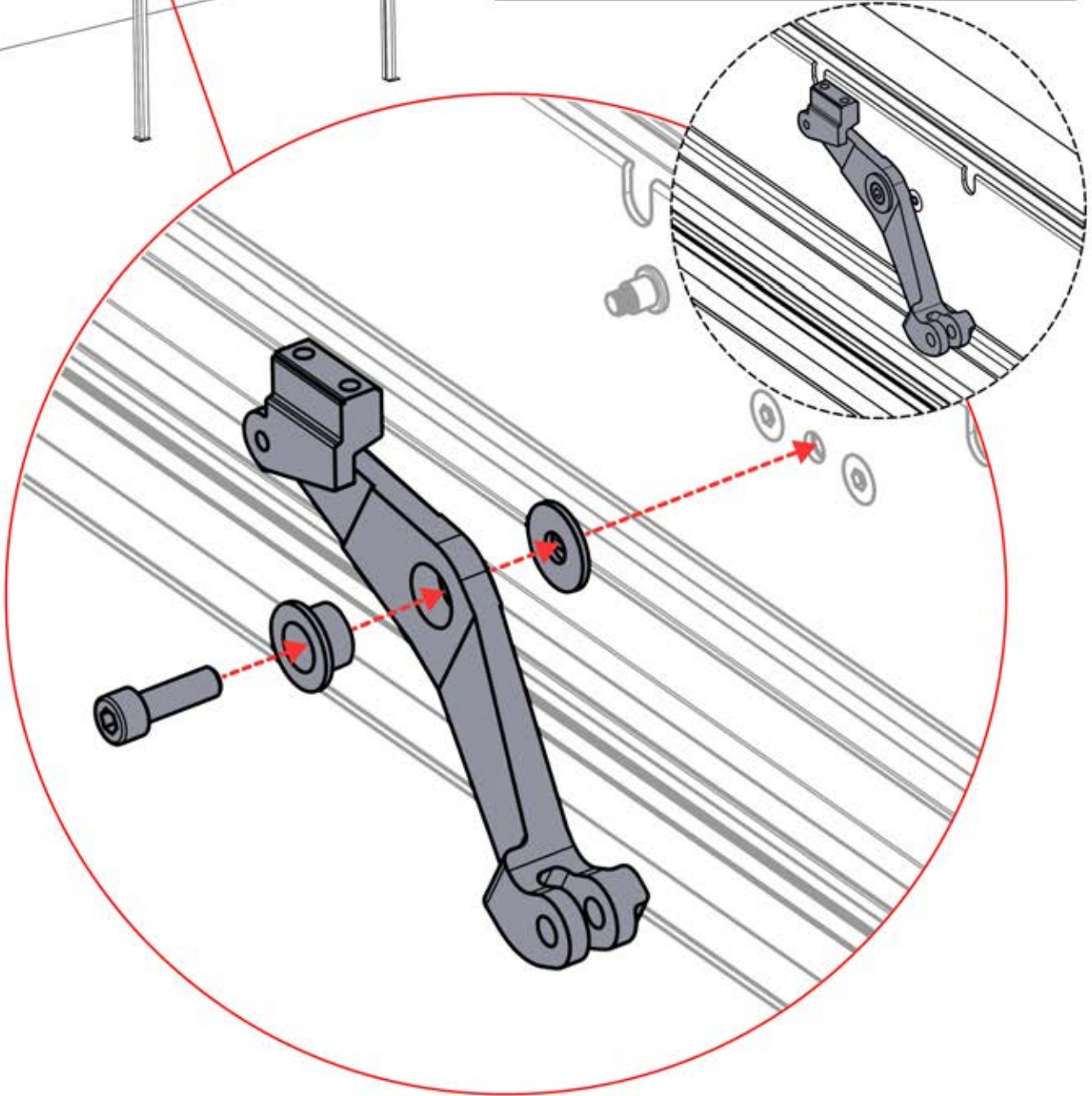

32

 **7**
ELECTRIC MOTEUR

 **4**
ANTHRACITE: B233
BLANC: B241
NOIR: B237

 PN-200001562
1x

 PN-200001946
1x

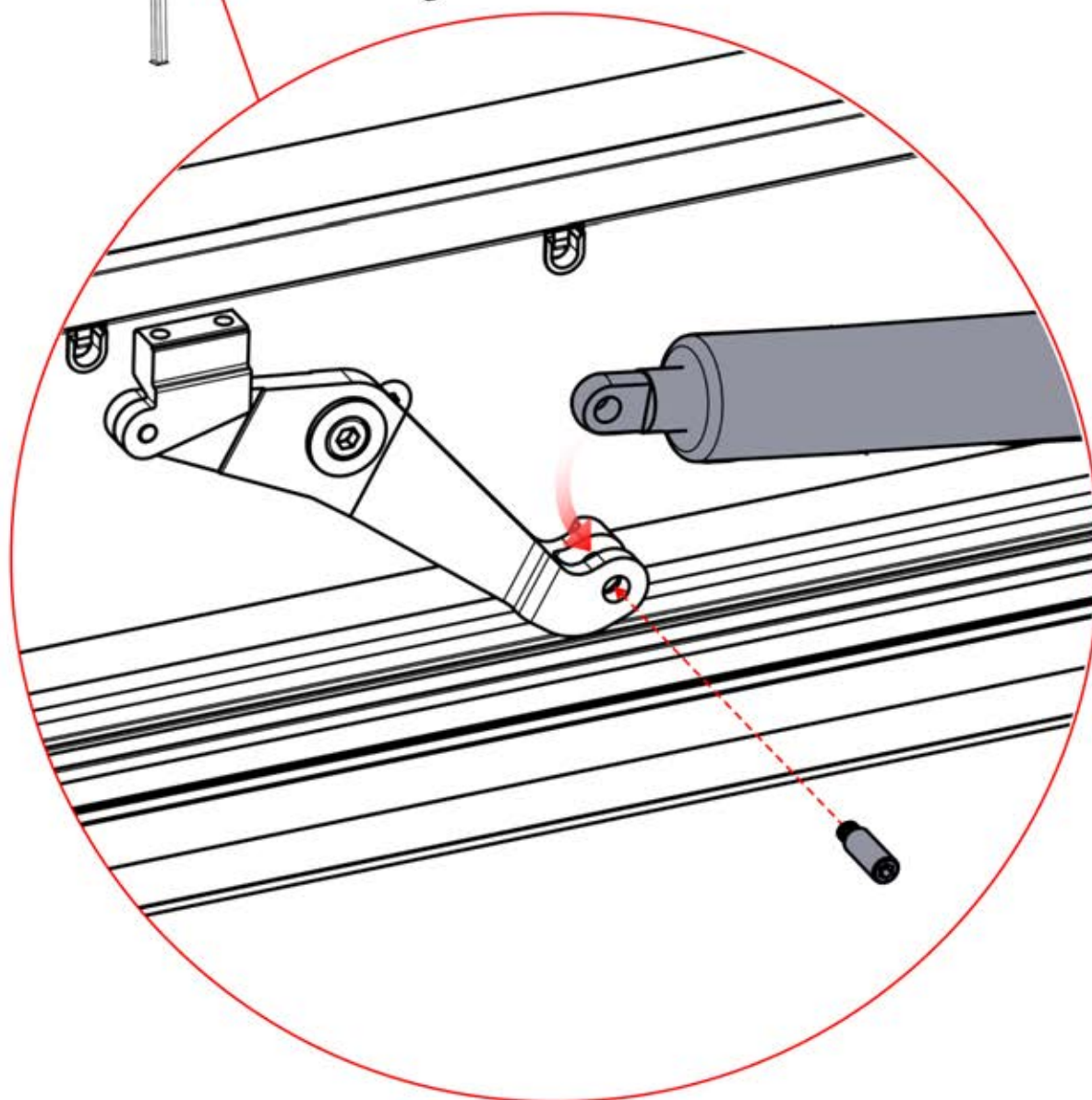
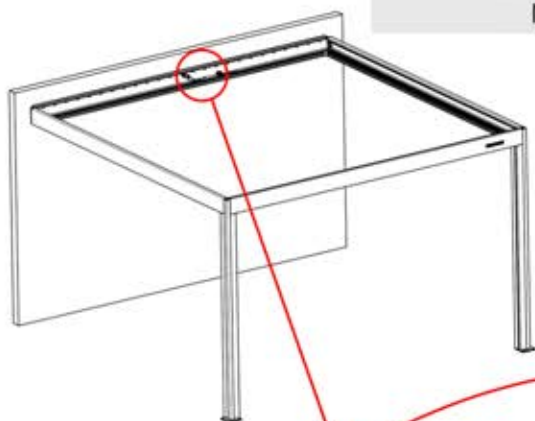

ENTRÉES ET SORTIES

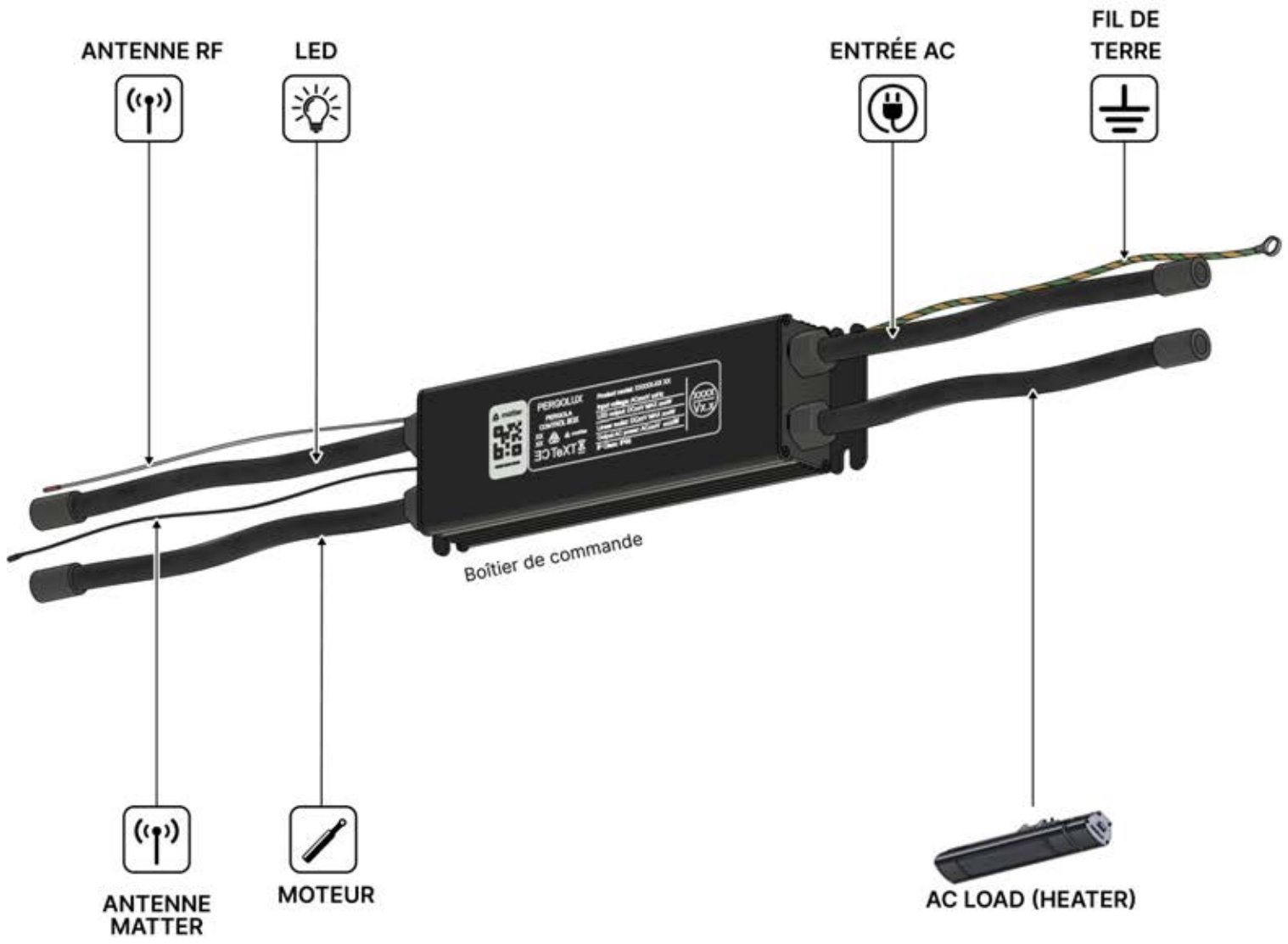

INFORMATION

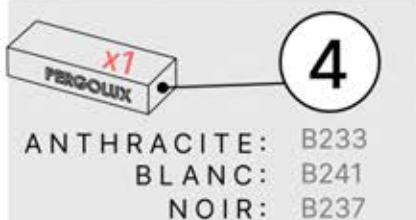
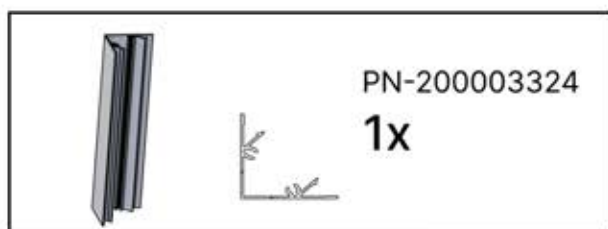

Si vous prévoyez de faire passer le câble d'alimentation par les coins arrière, percez un trou de 10 mm de diamètre dans le cache d'angle (réf. **200003324**) comme illustré. Cela permettra au câble de passer lors de l'installation à l'étape 58.

Remarque : l'illustration indique l'emplacement du trou pour un montage dans le coin droit ; si le montage s'effectue à partir du coin gauche, percez le trou du côté opposé.

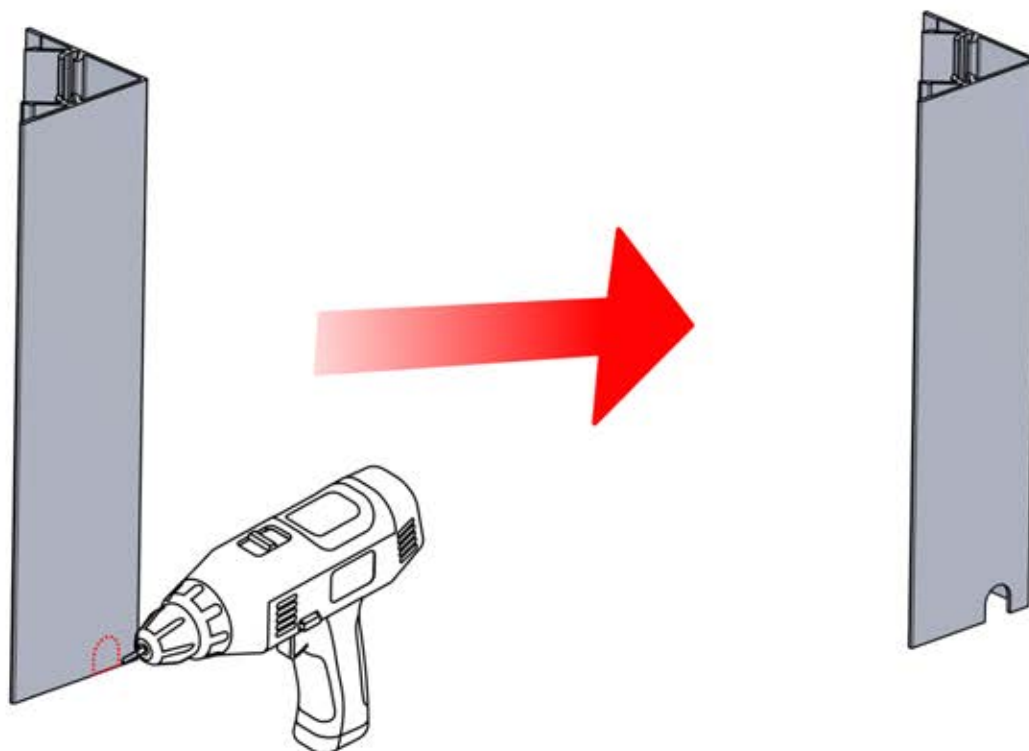

33

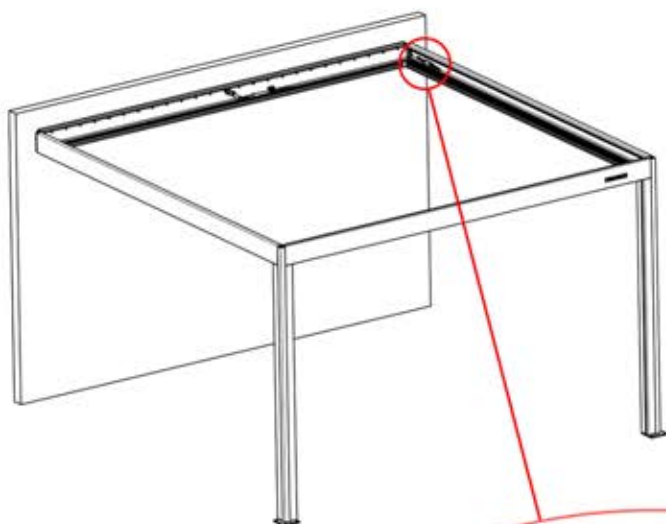

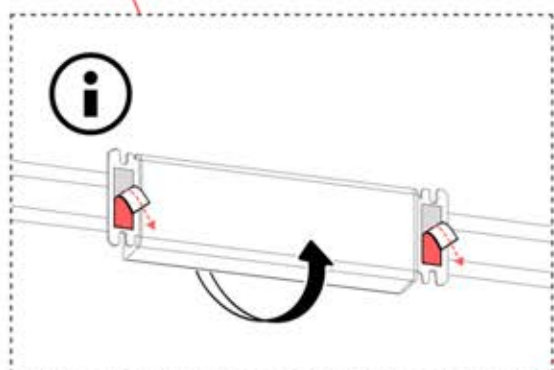
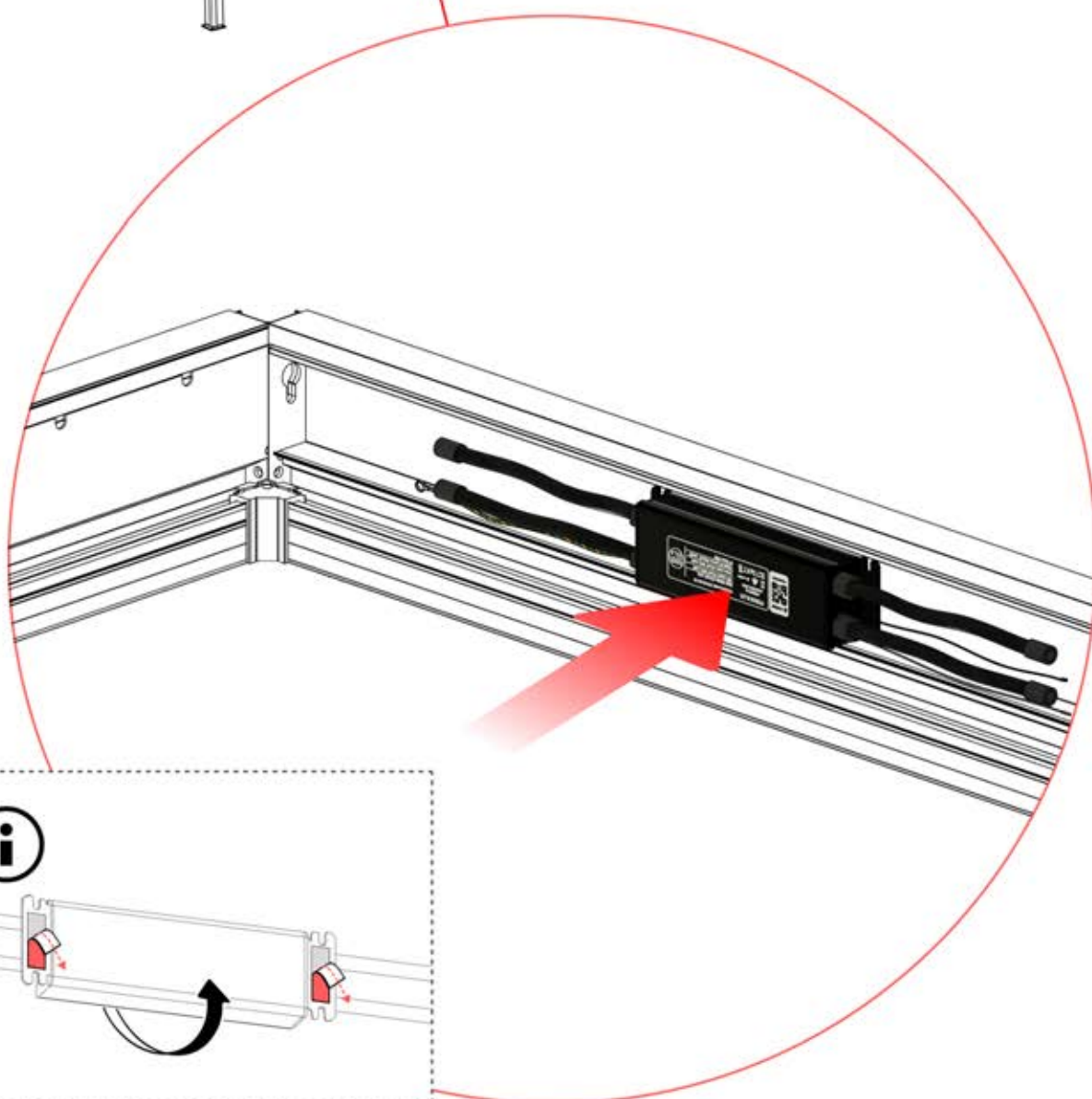

! Le boîtier de commande peut être installé sur la poutre en W de votre choix

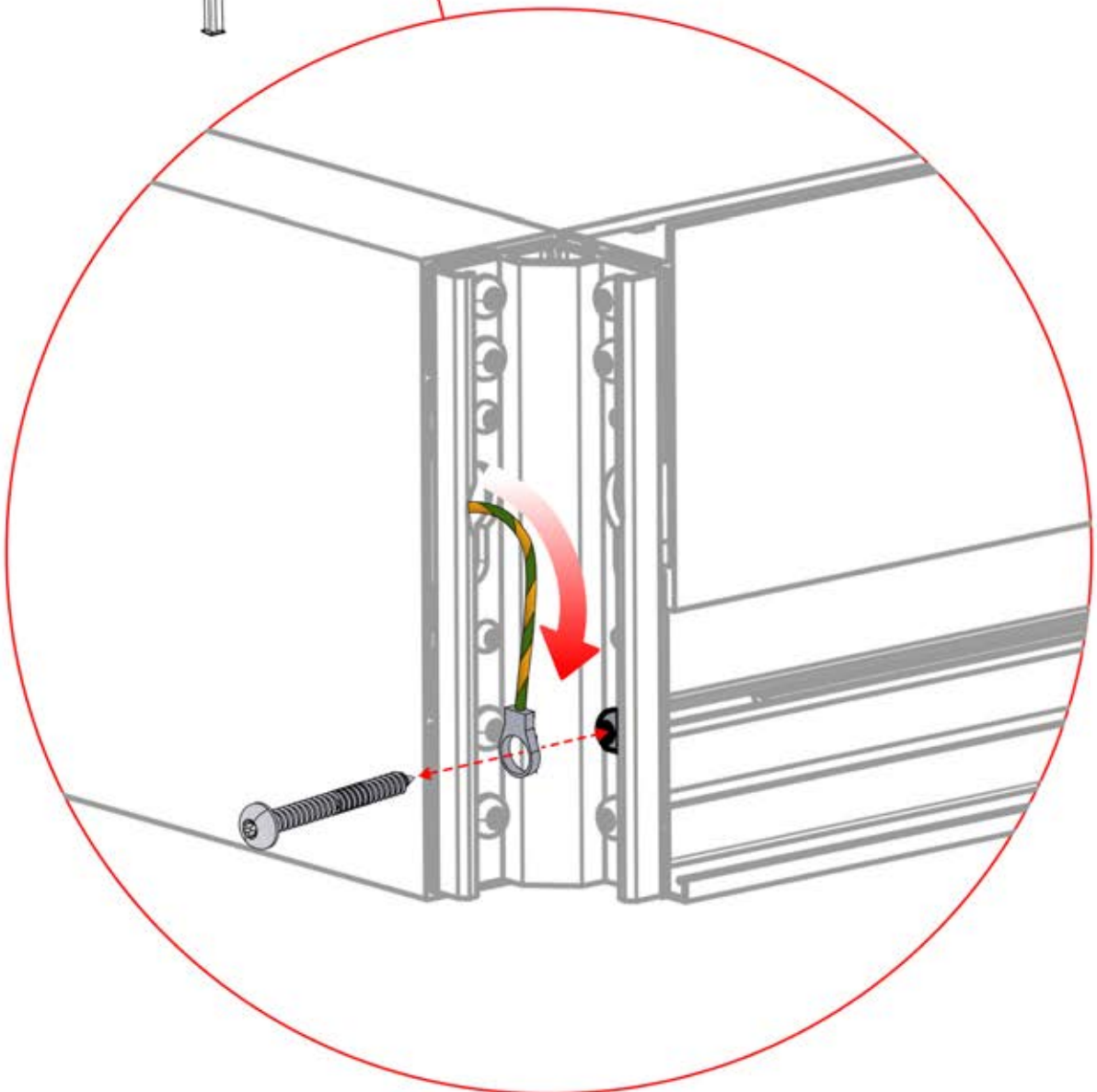
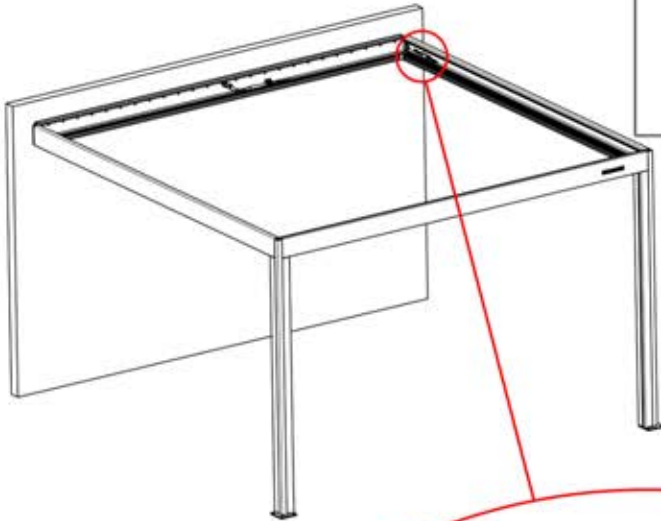

34

 **Raccordez le fil de terre avant de brancher l'appareil sur le secteur !**



35

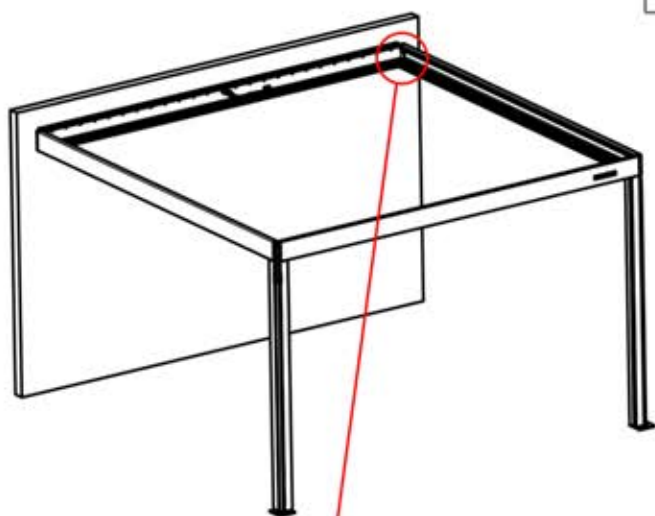
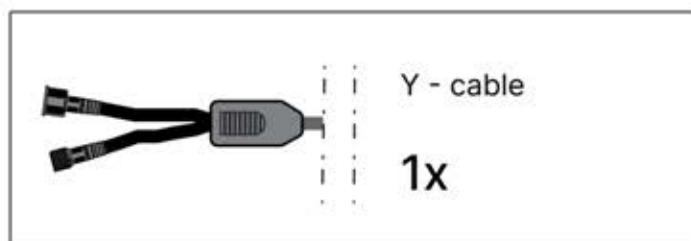

36

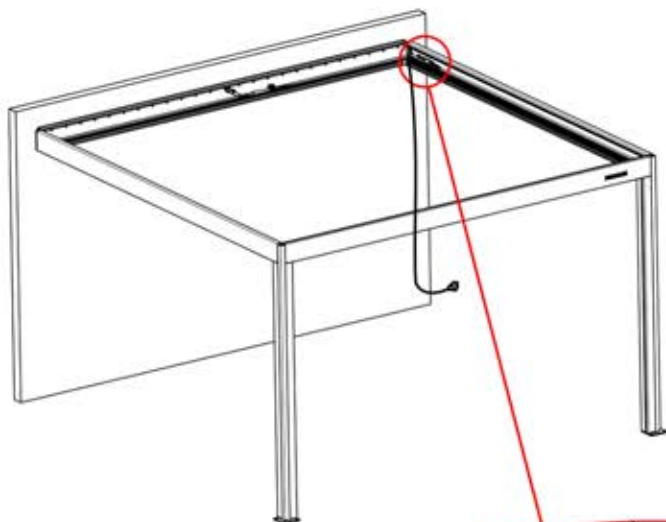
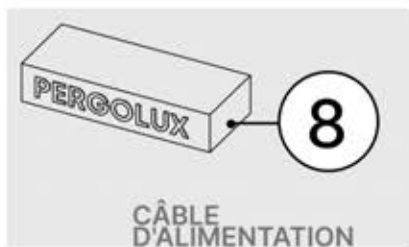

!
Le câble d'alimentation peut passer par tous les poteaux.

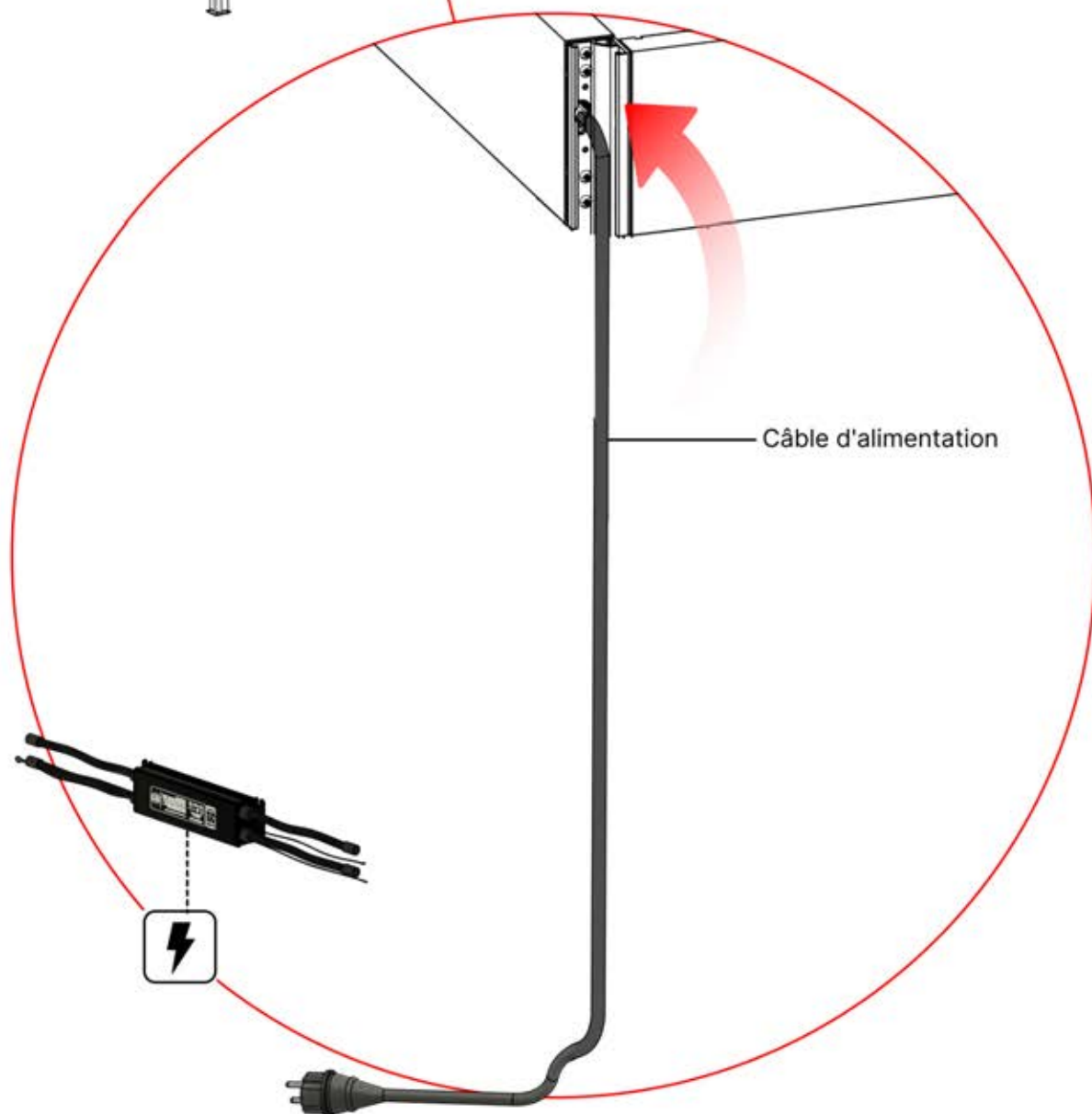

37

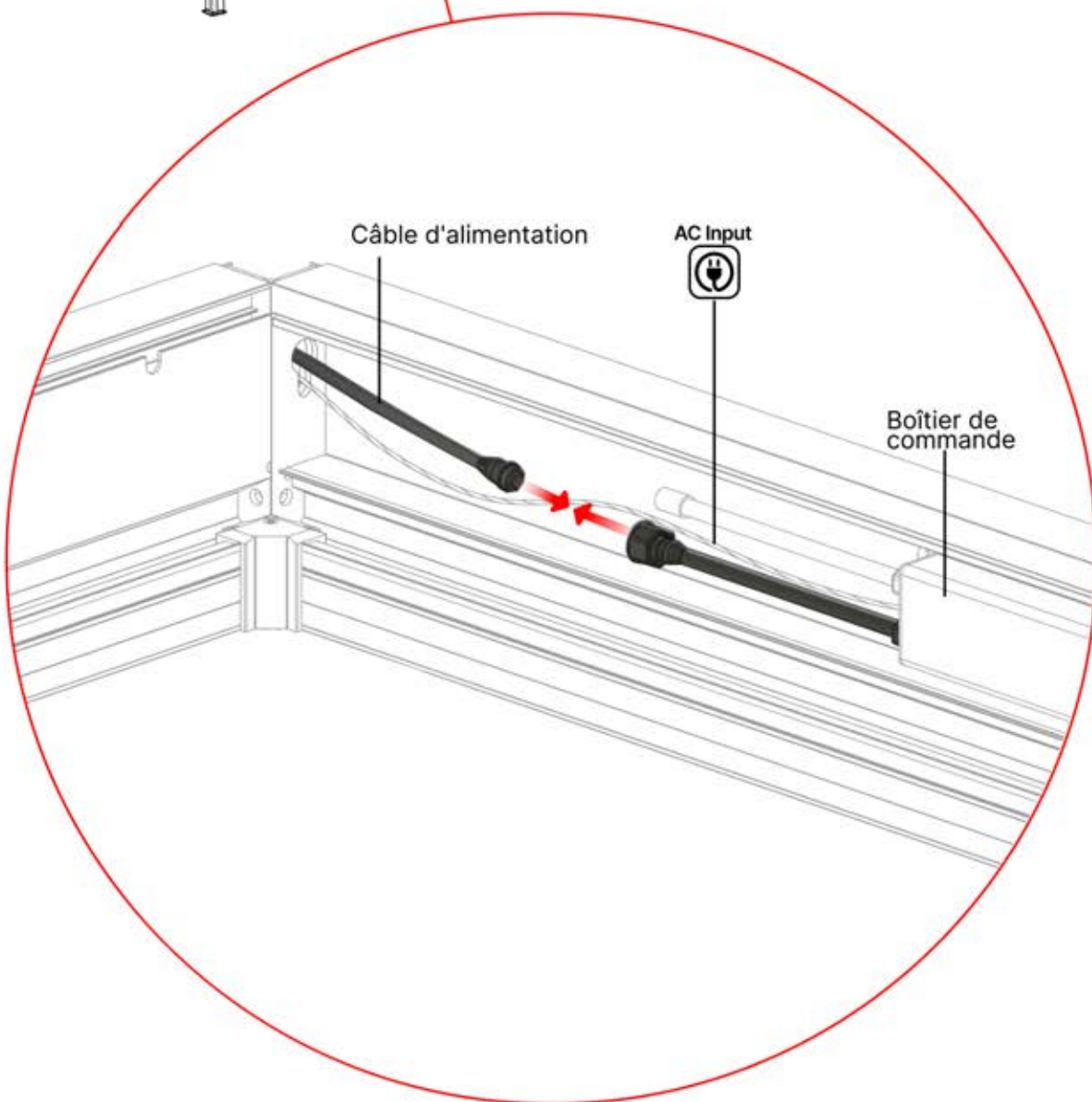
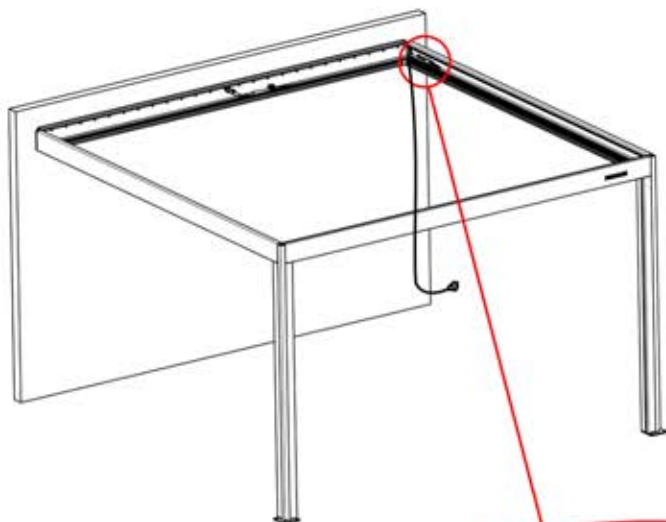
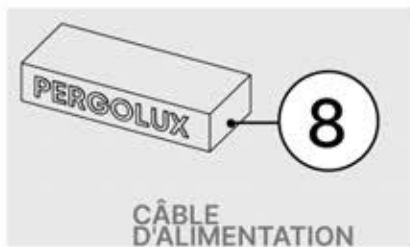

38

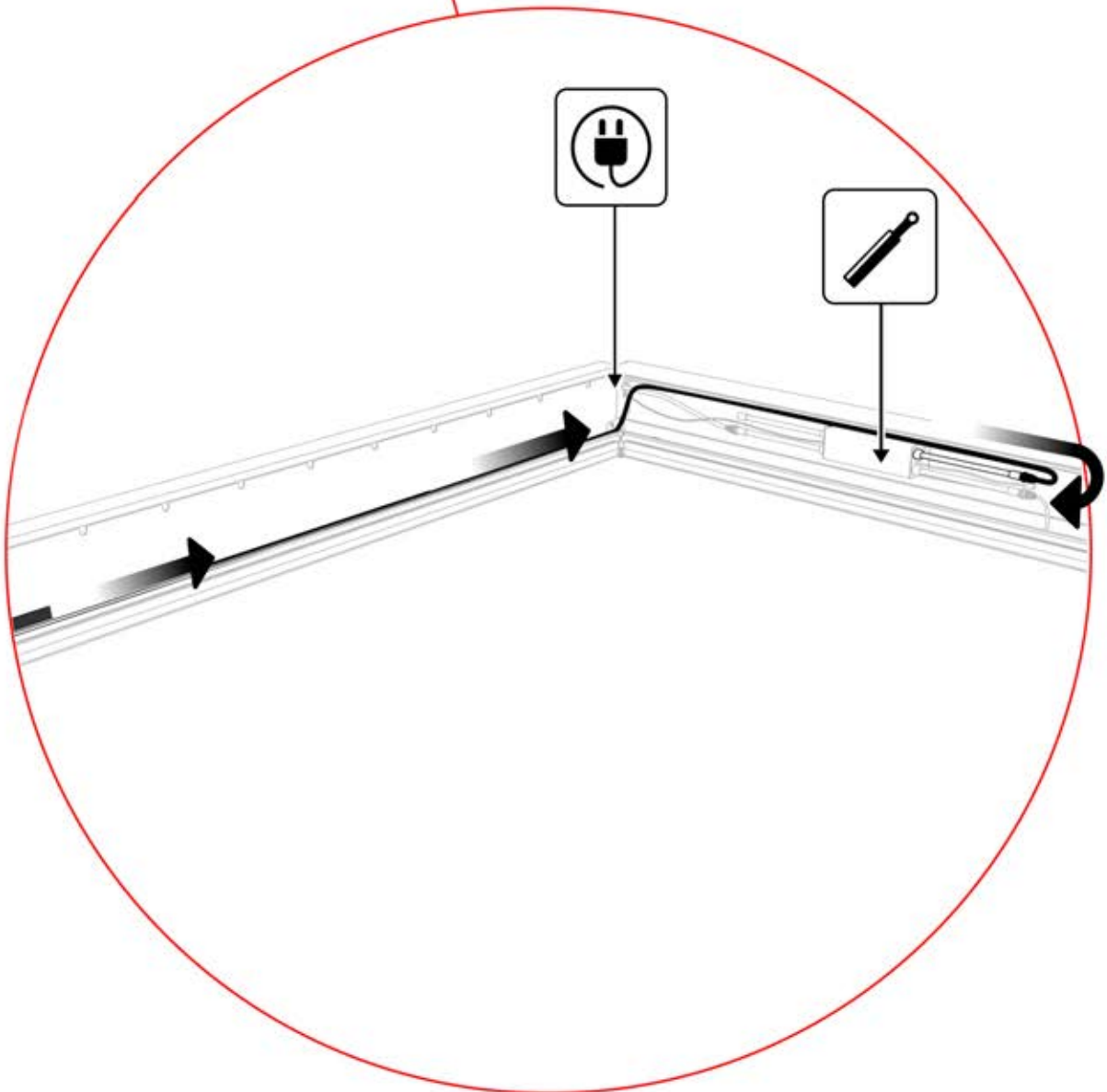
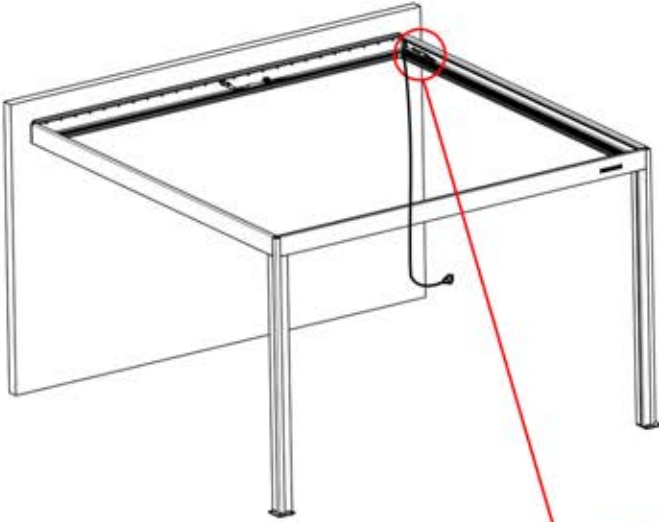

39

1

Une lampe
chauffante ?
Faites-le
maintenant.

Suivez les instructions du
manuel de montage de la
lampe chauffante.

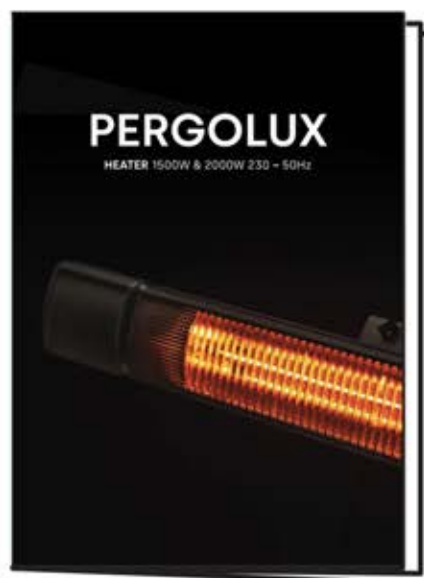



2

C'est le moment de
connecter le
moteur et les LEDs
au boîtier de
commande de la
pergola.

Suivez les instructions du
manuel de montage.

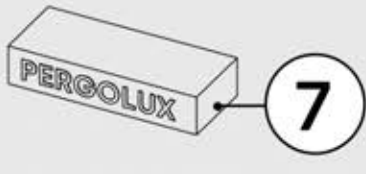

40

 <p>BOÎTIER DE COMMANDE</p>	S4	PN-200002683
<p>⚠ Veillez à ce que le fil de l'antenne ne soit pas enroulé et ne le nouez pas avec les fils de la LED et du moteur</p>		5x
		PN-200002684 10x

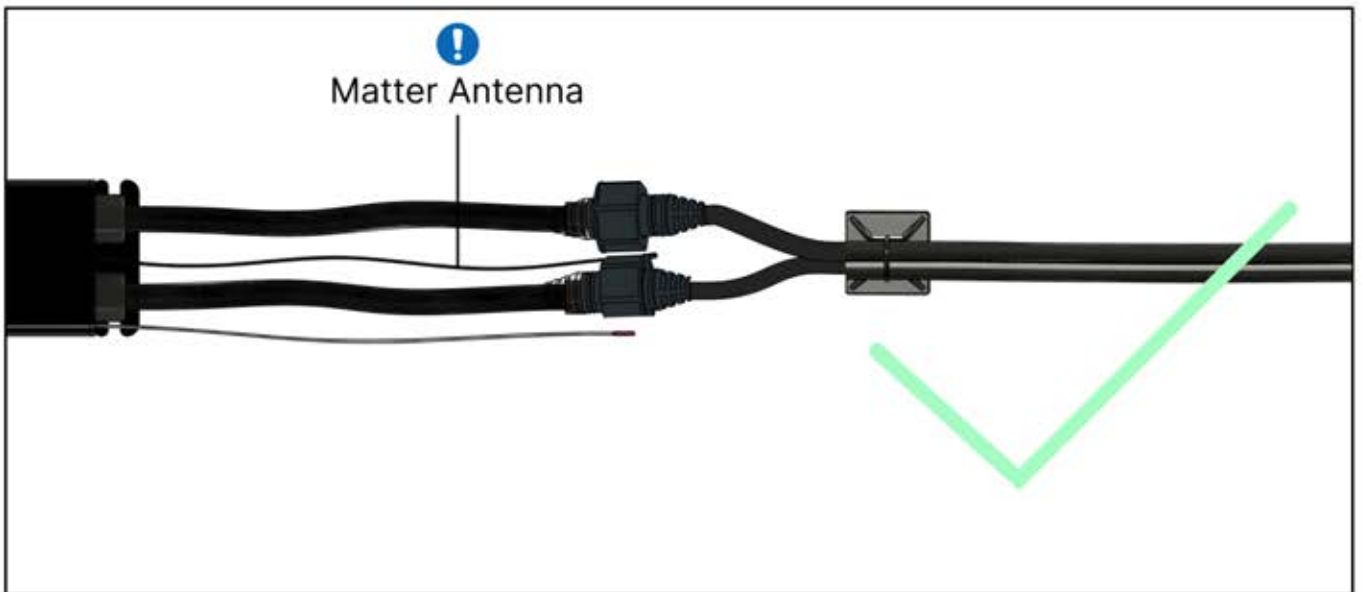
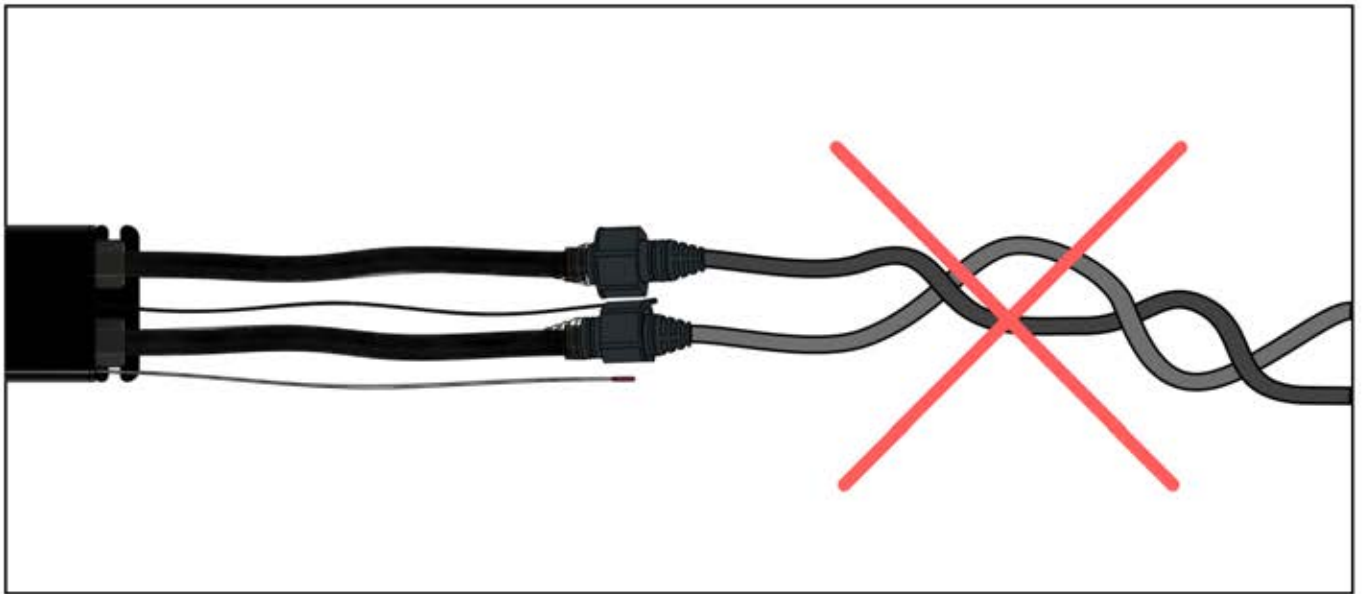

41

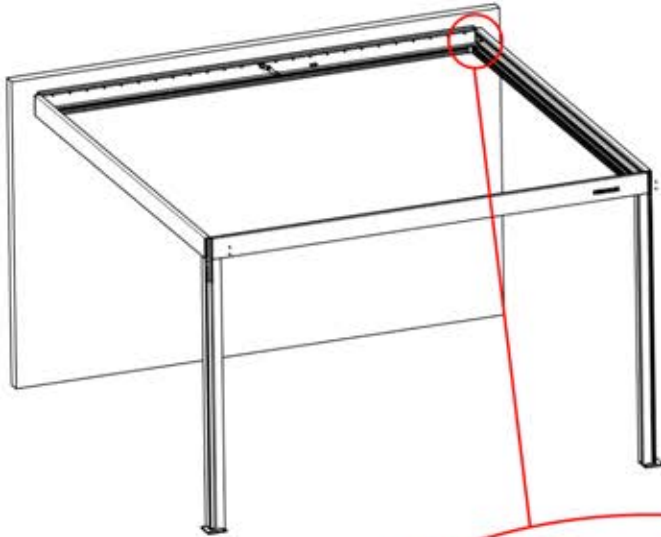

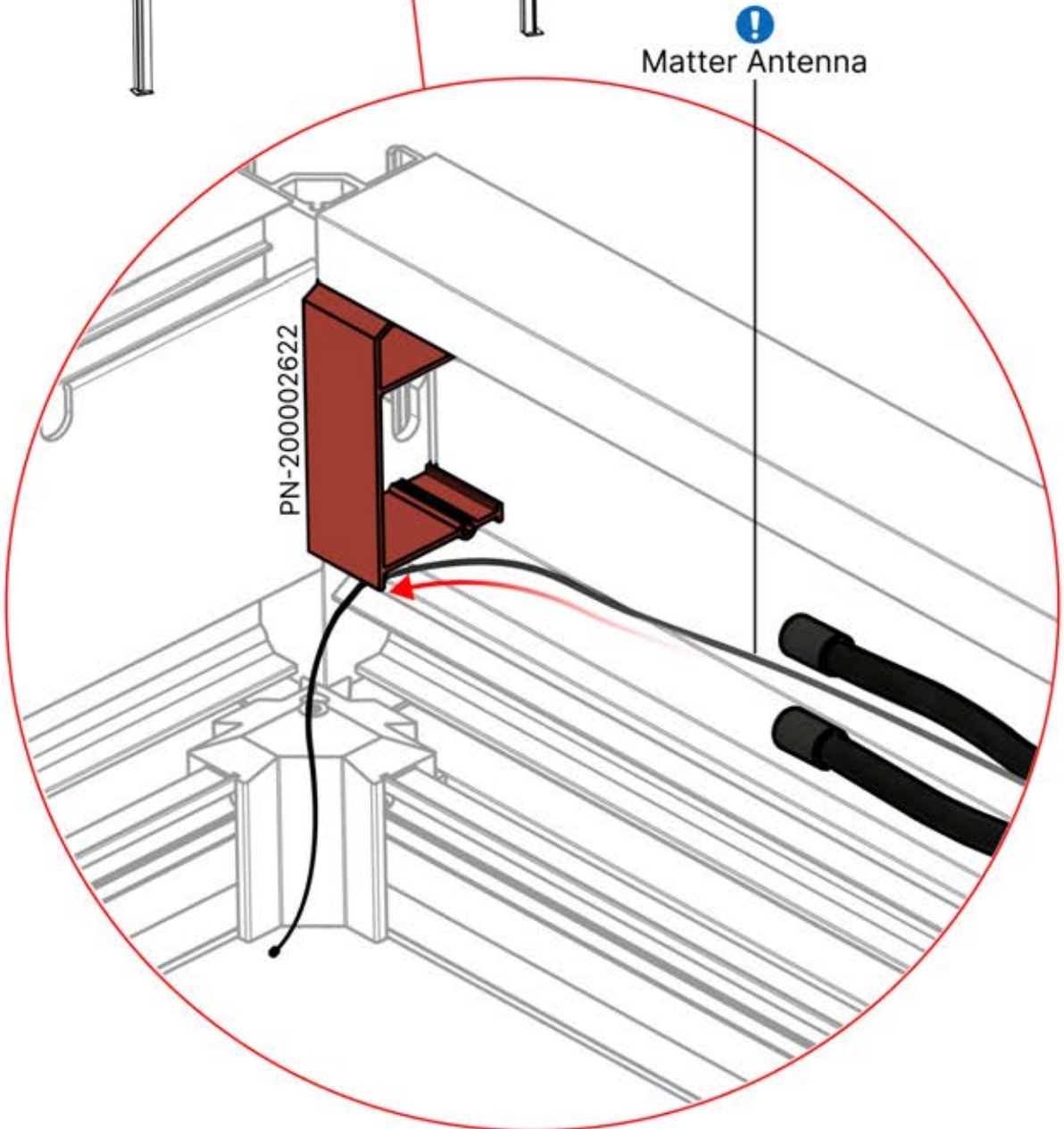

!
Dirigez l'antenne Matter et placez-la sous la pièce mise en évidence (réf. 200002622).



!
Matter Antenna

42

	5		PN-200003329
ANTHRACITE: B263			1x
BLANC: B267			
NOIR: B265			

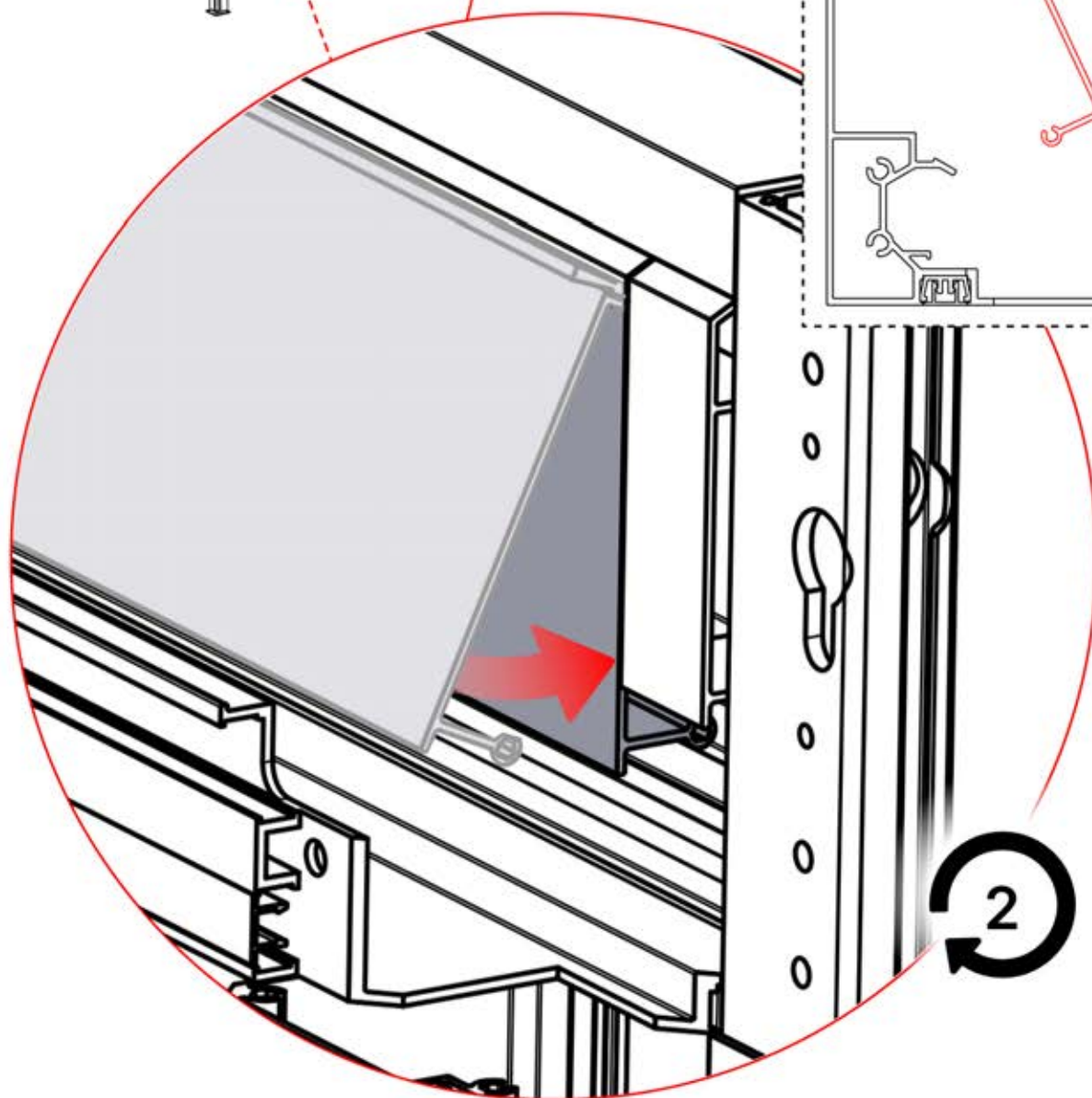
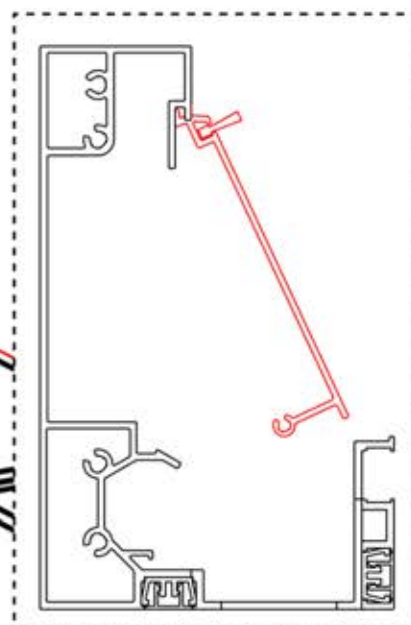
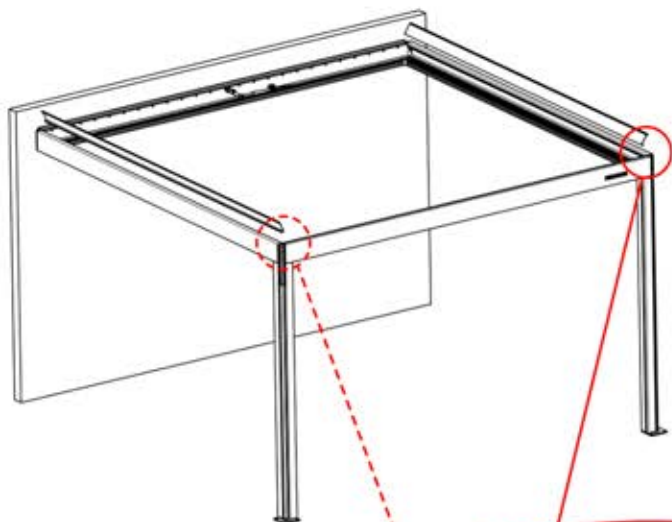

INFORMATION

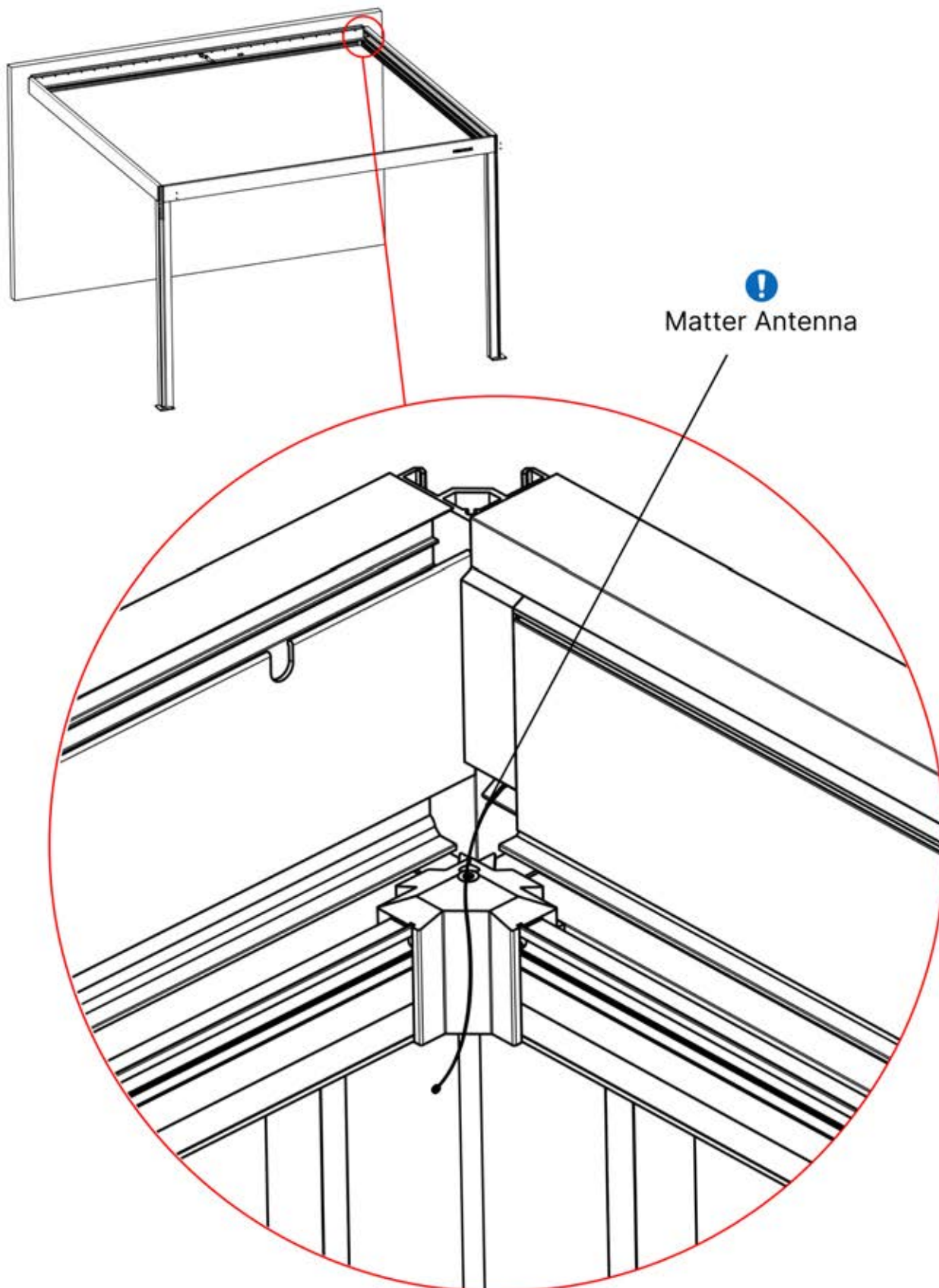

43

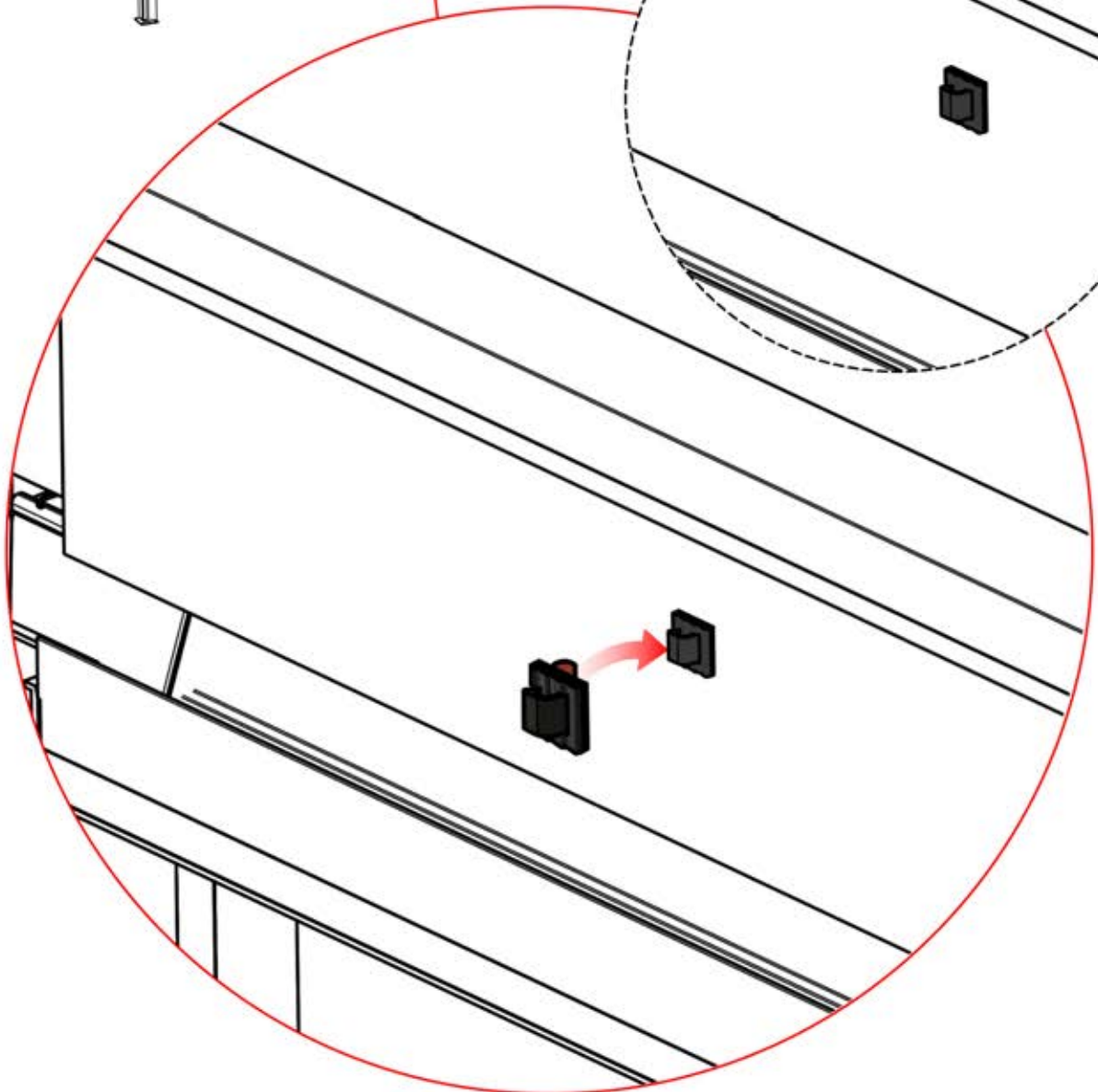
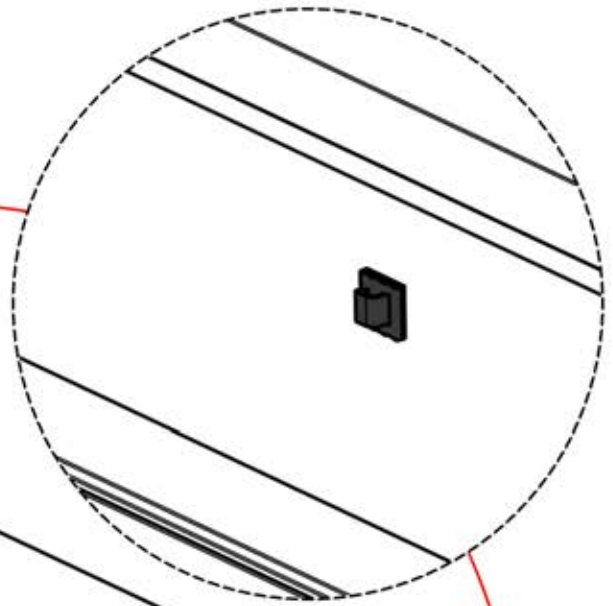
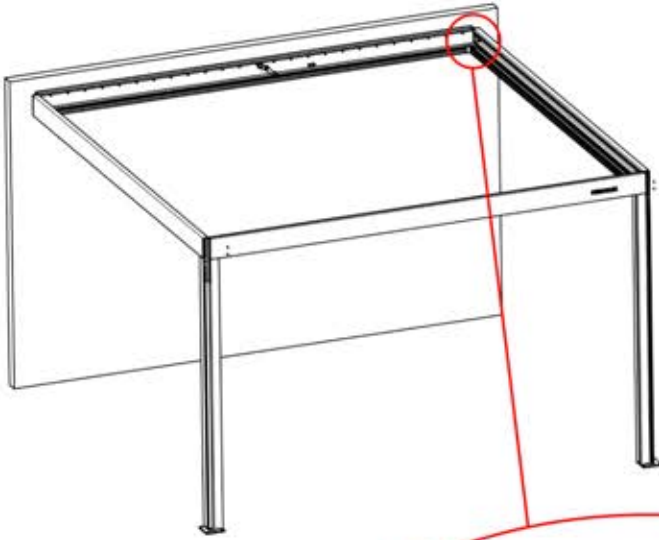

44

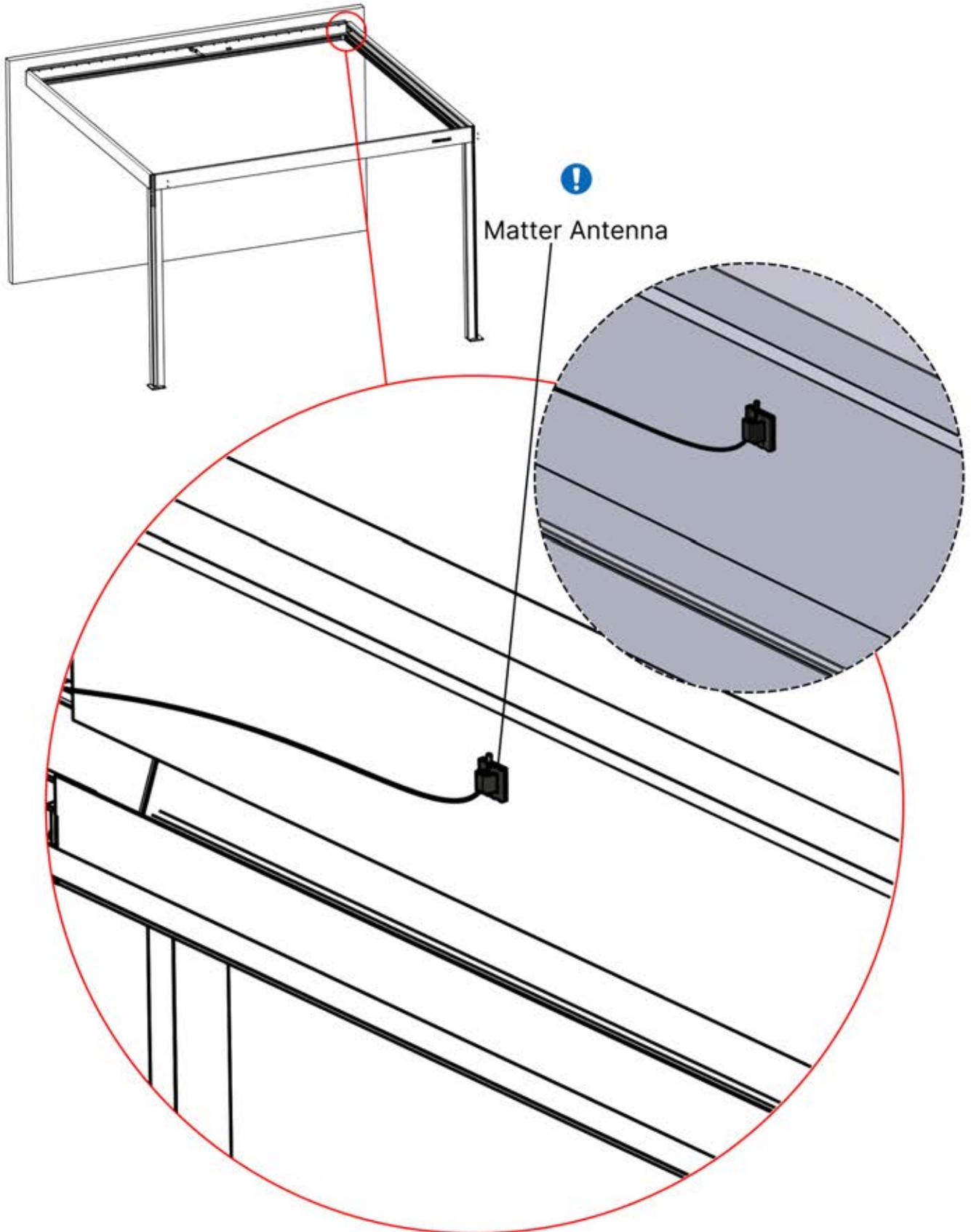

45



Remote
Controller

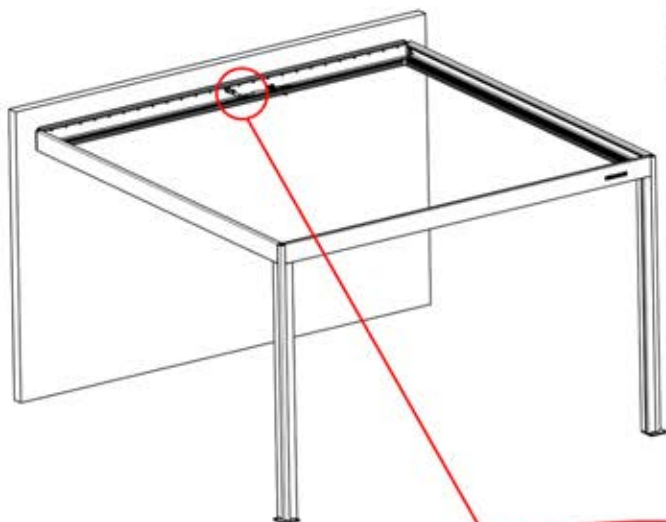

Réglez le moteur en
vue de son
montage à l'étape 46

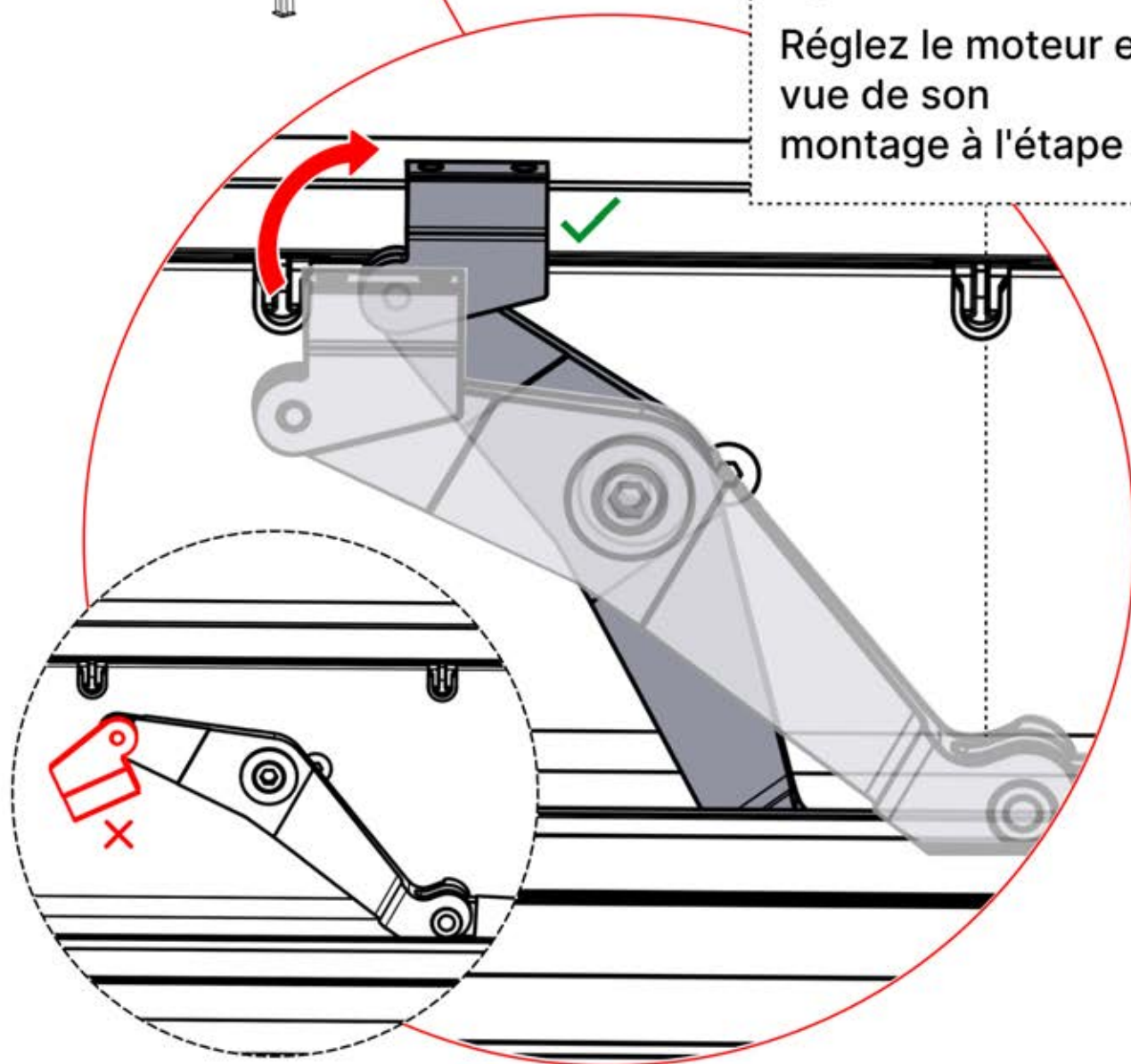

46



4

ANTHRACITE: B245
BLANC: B253
NOIR: B249

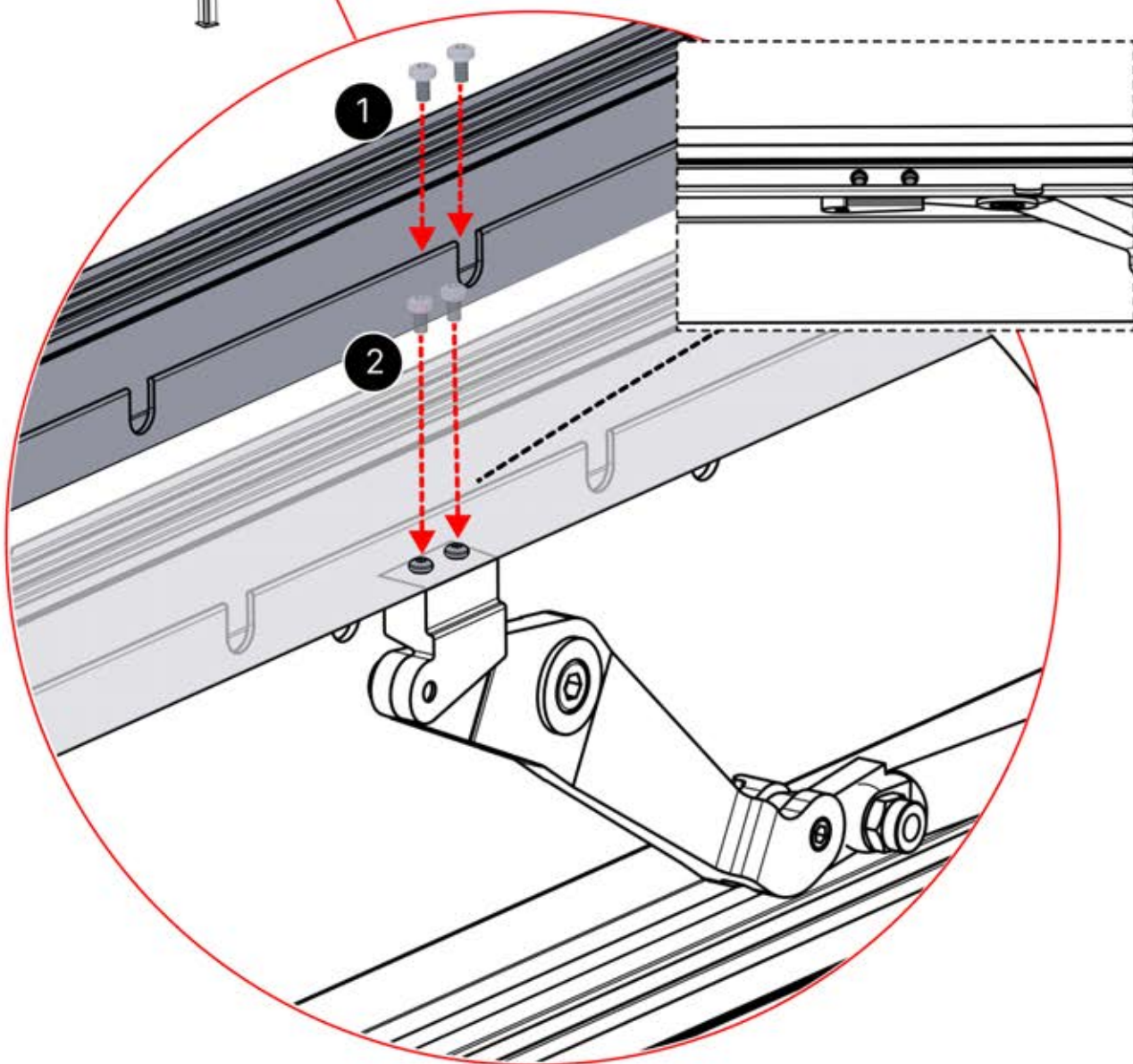
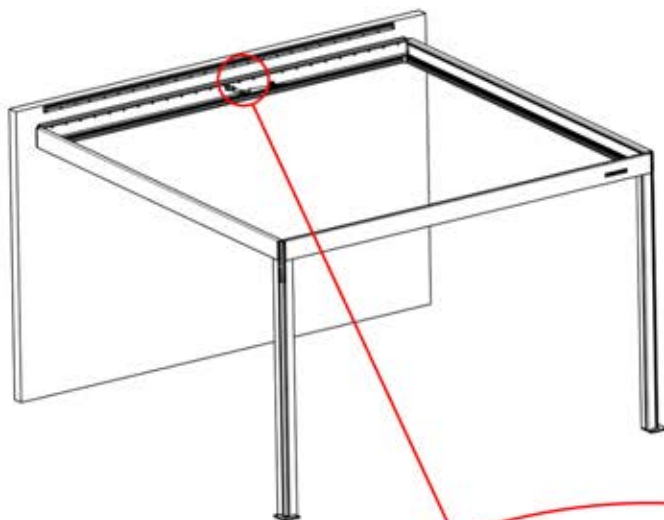

CONTENU DES COLIS

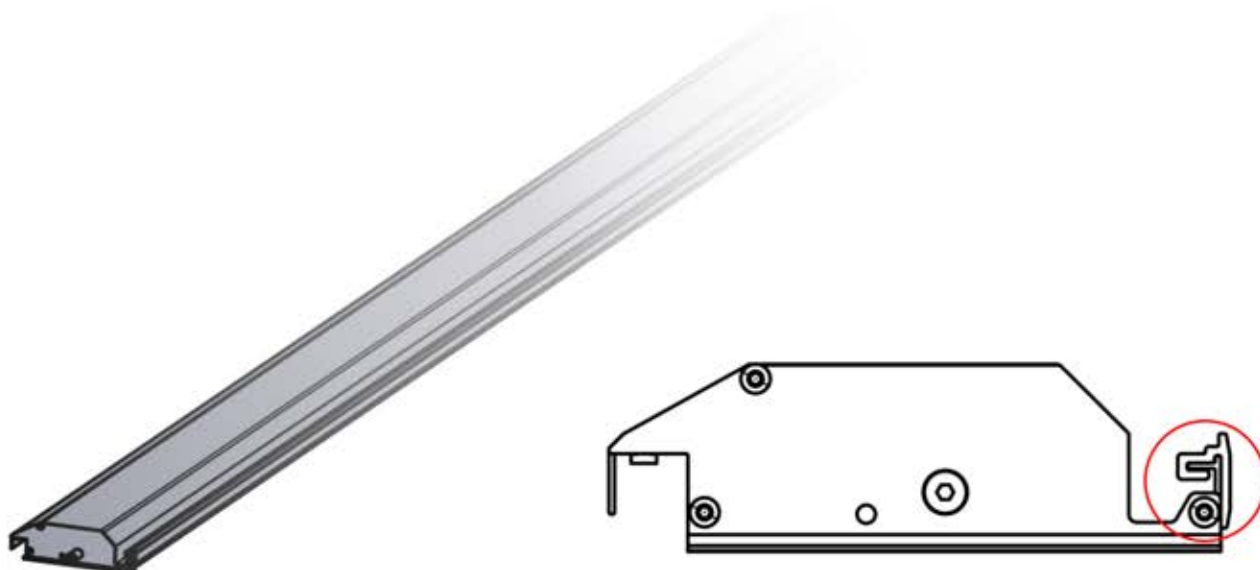

PLR 150 G2 PRO LOUVER END FS 4M
PACKAGE

PN-200002975

1x

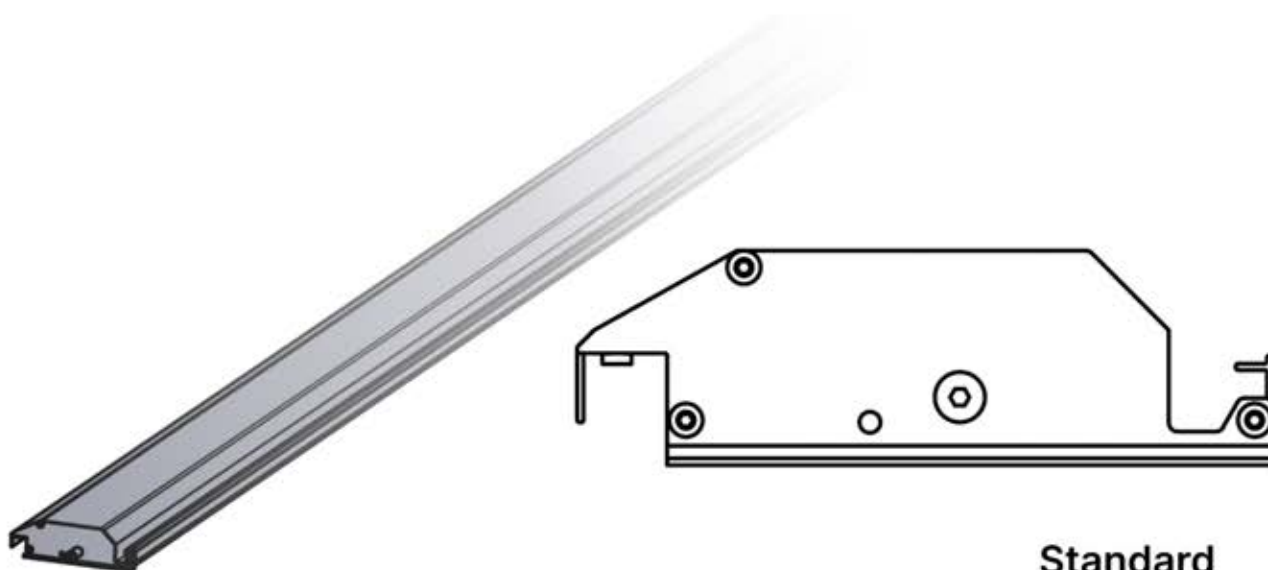

PLR 150 G2 PRO LOUVER STD FS 4M
PACKAGE

PN-200002883

18x

Standard

47

x3
PERGOLUX
PERGOLUX
PERGOLUX

2

ANTHRACITE: L222
BLANC: L226
NOIR: L224



PN-200002883
1x

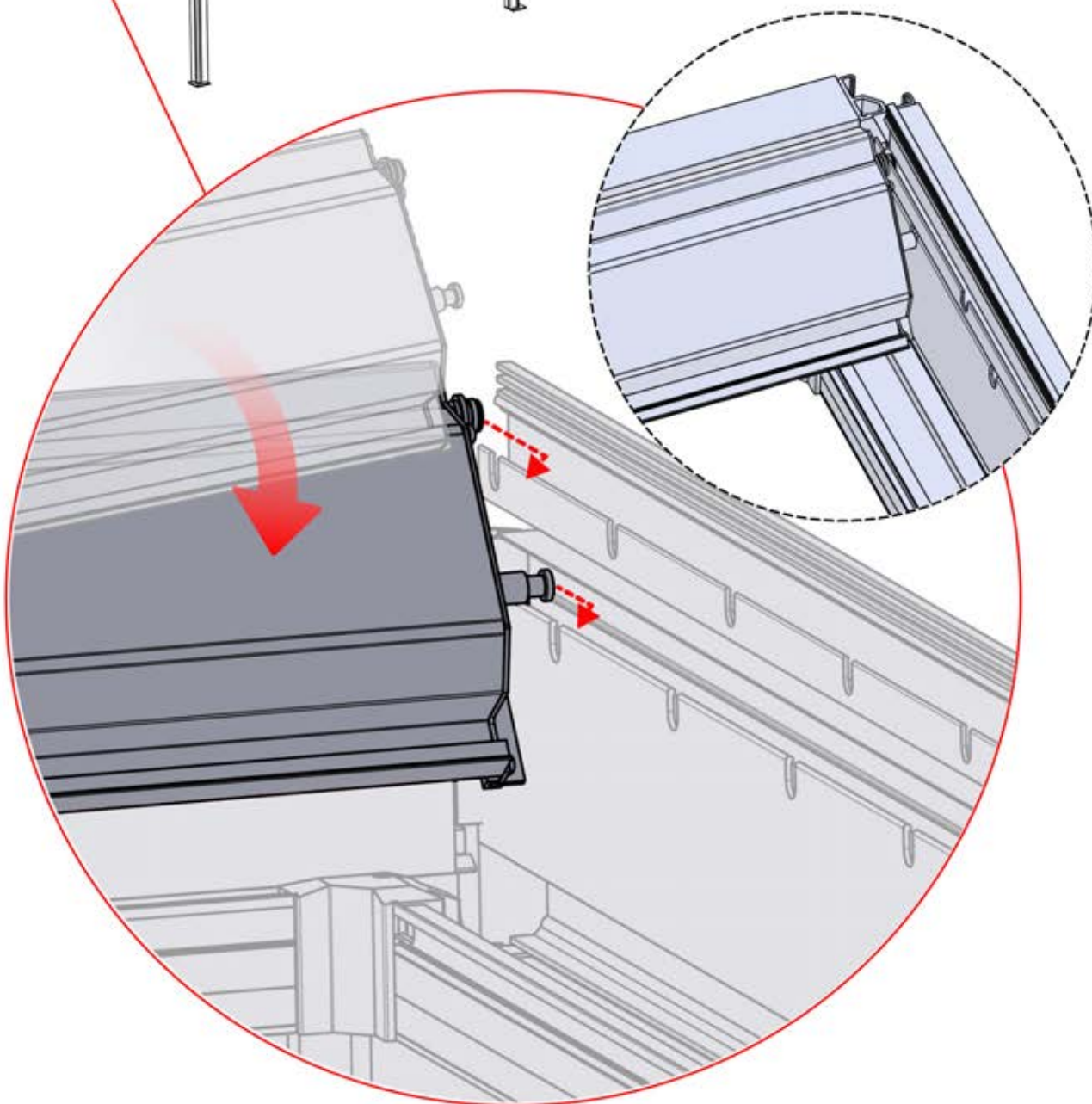
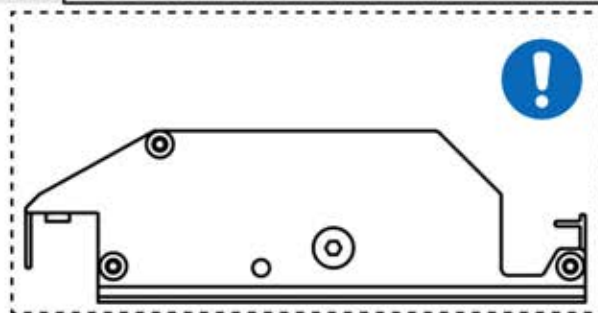

48

x3
FERGOLUX
FERGOLUX
FERGOLUX

2

ANTHRACITE: L222
BLANC: L226
NOIR: L224



PN-200002883
1x

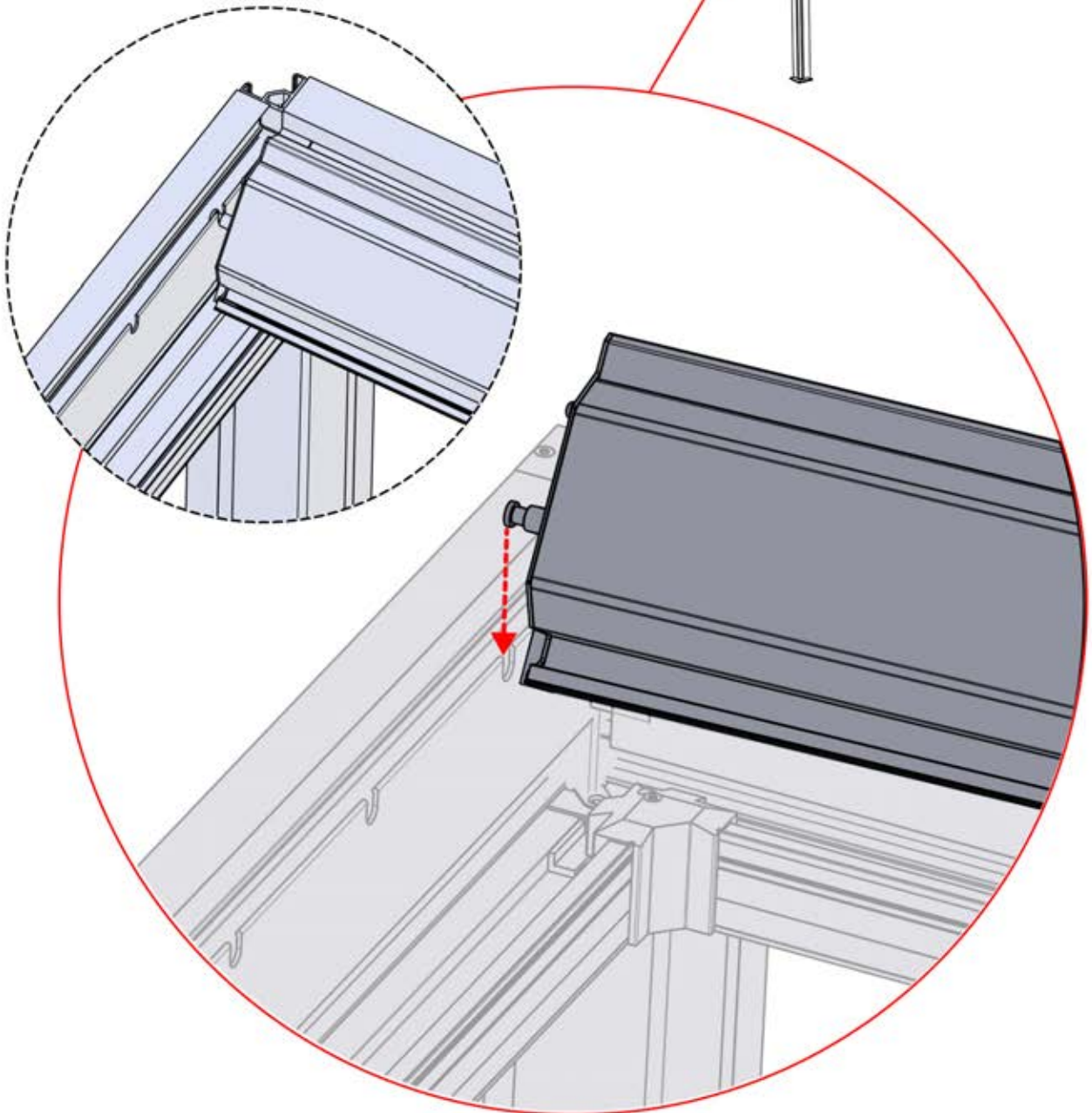
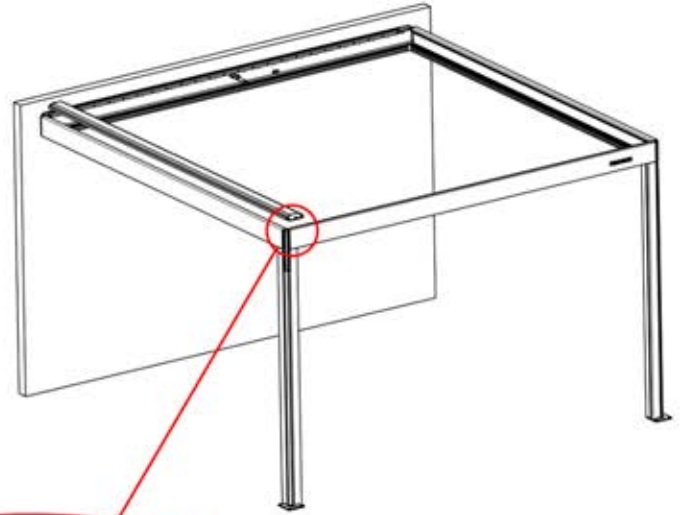

49



4

ANTHRACITE: B245
BLANC: B253
NOIR: B249

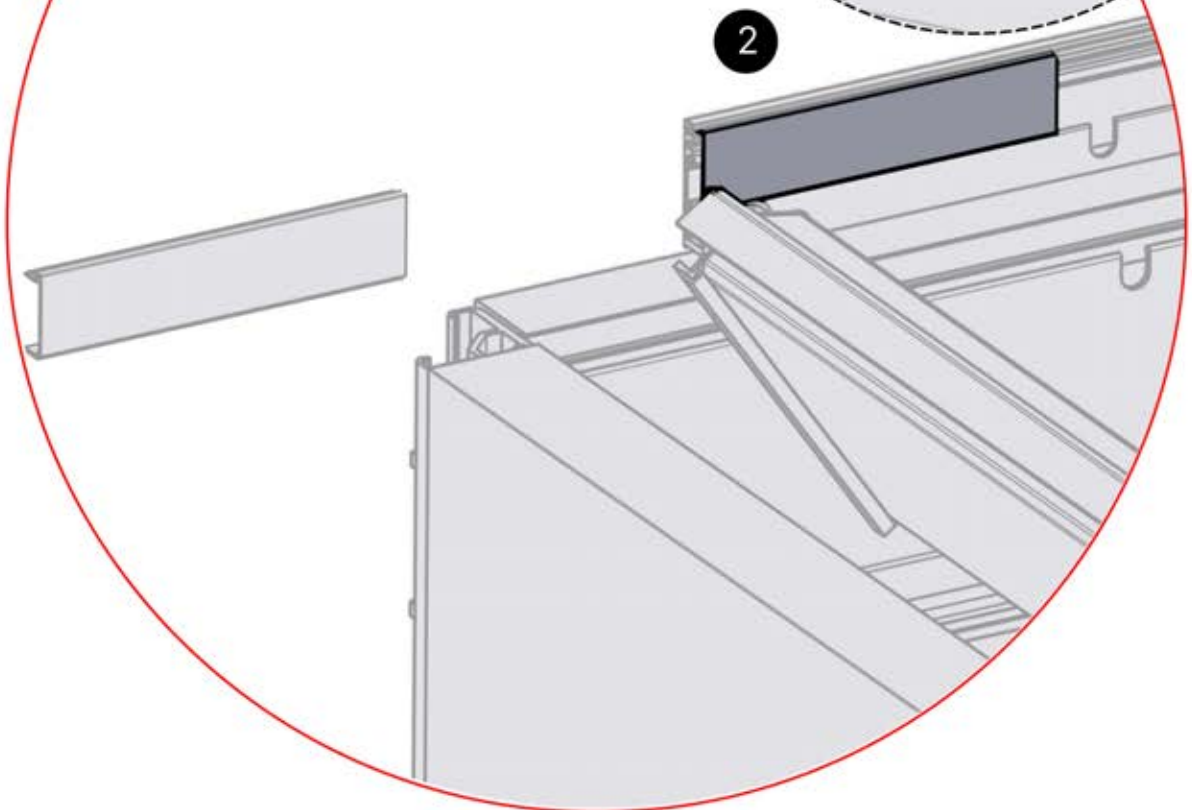
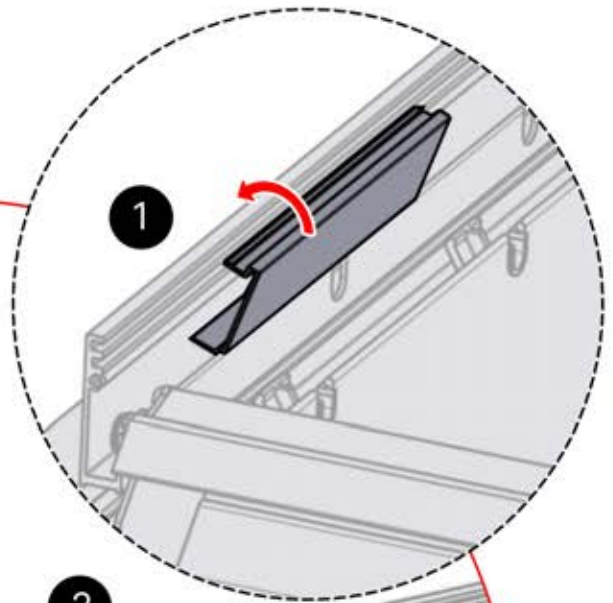
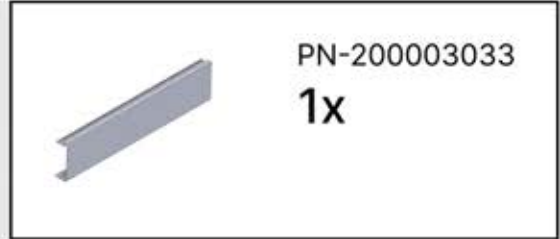

50

x1
PERGOLUX

3

ANTHRACITE: L234
BLANC: L238
NOIR: L236

PN-200002975
1x

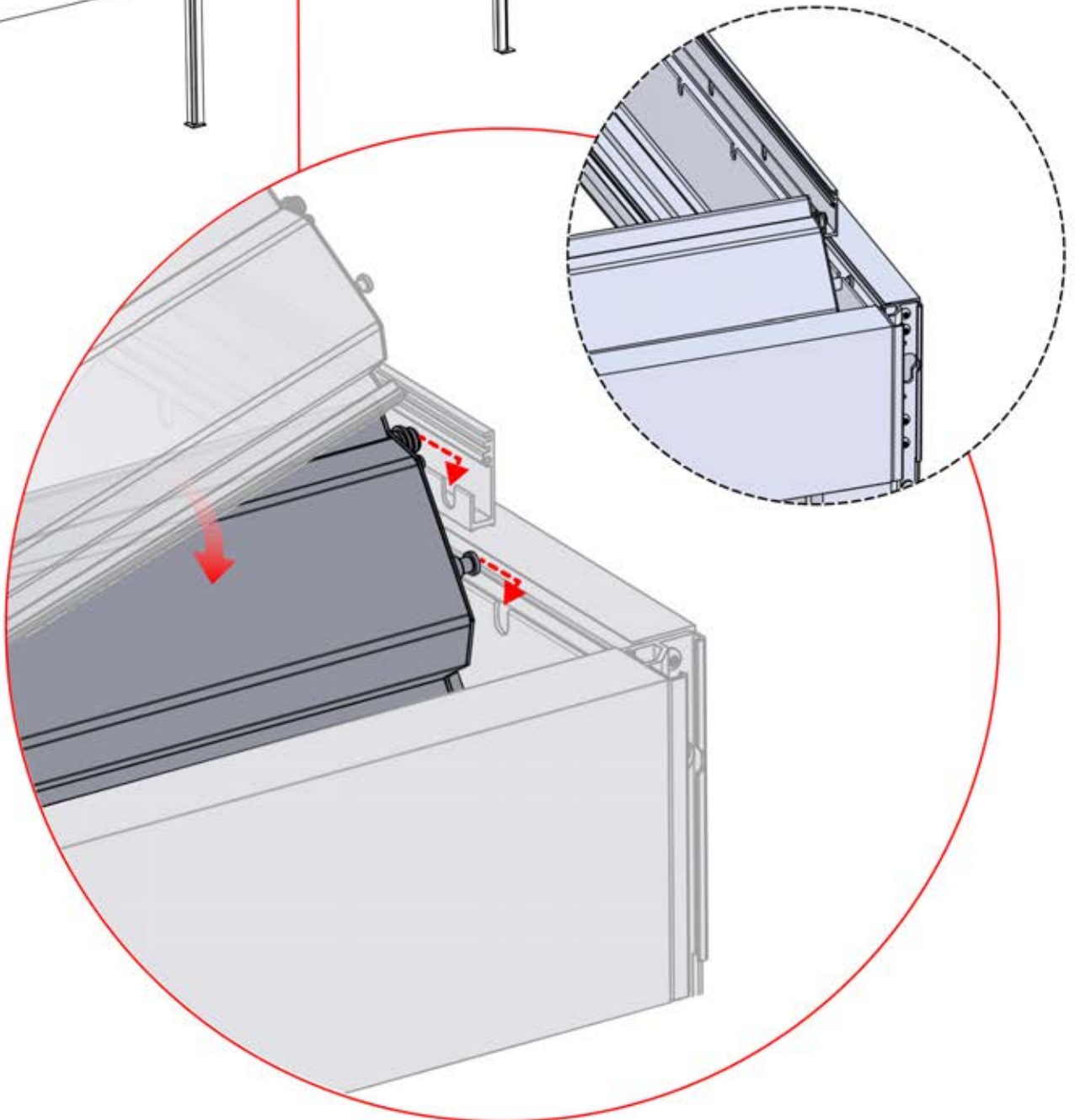
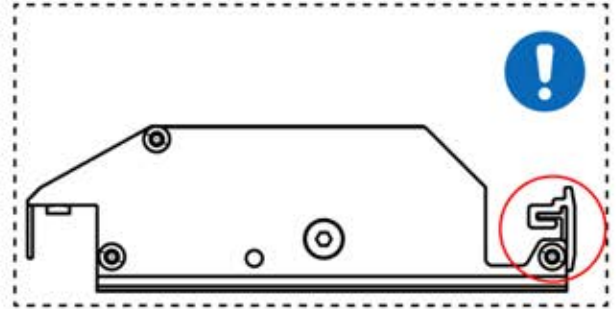
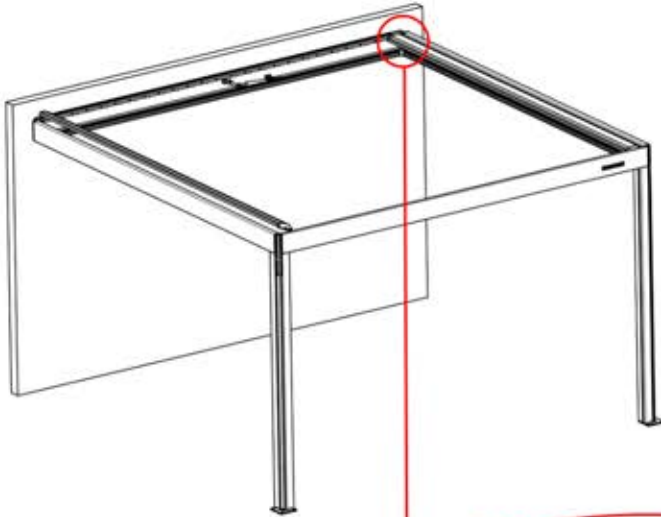

51

 **3**

ANTHRACITE: L234
BLANC: L238
NOIR: L236

 PN-200002975
1x

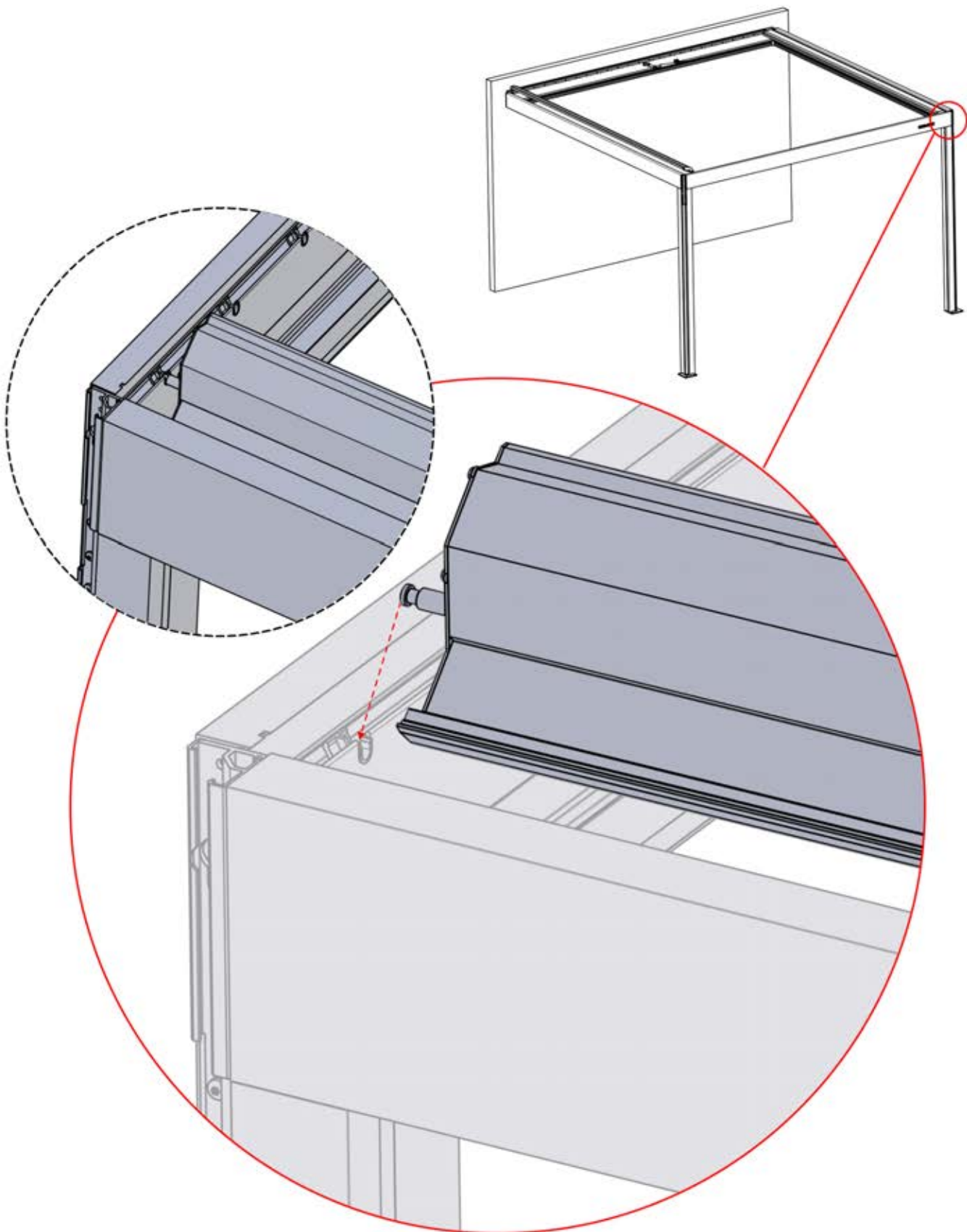

52



4

ANTHRACITE: B245
BLANC: B253
NOIR: B249

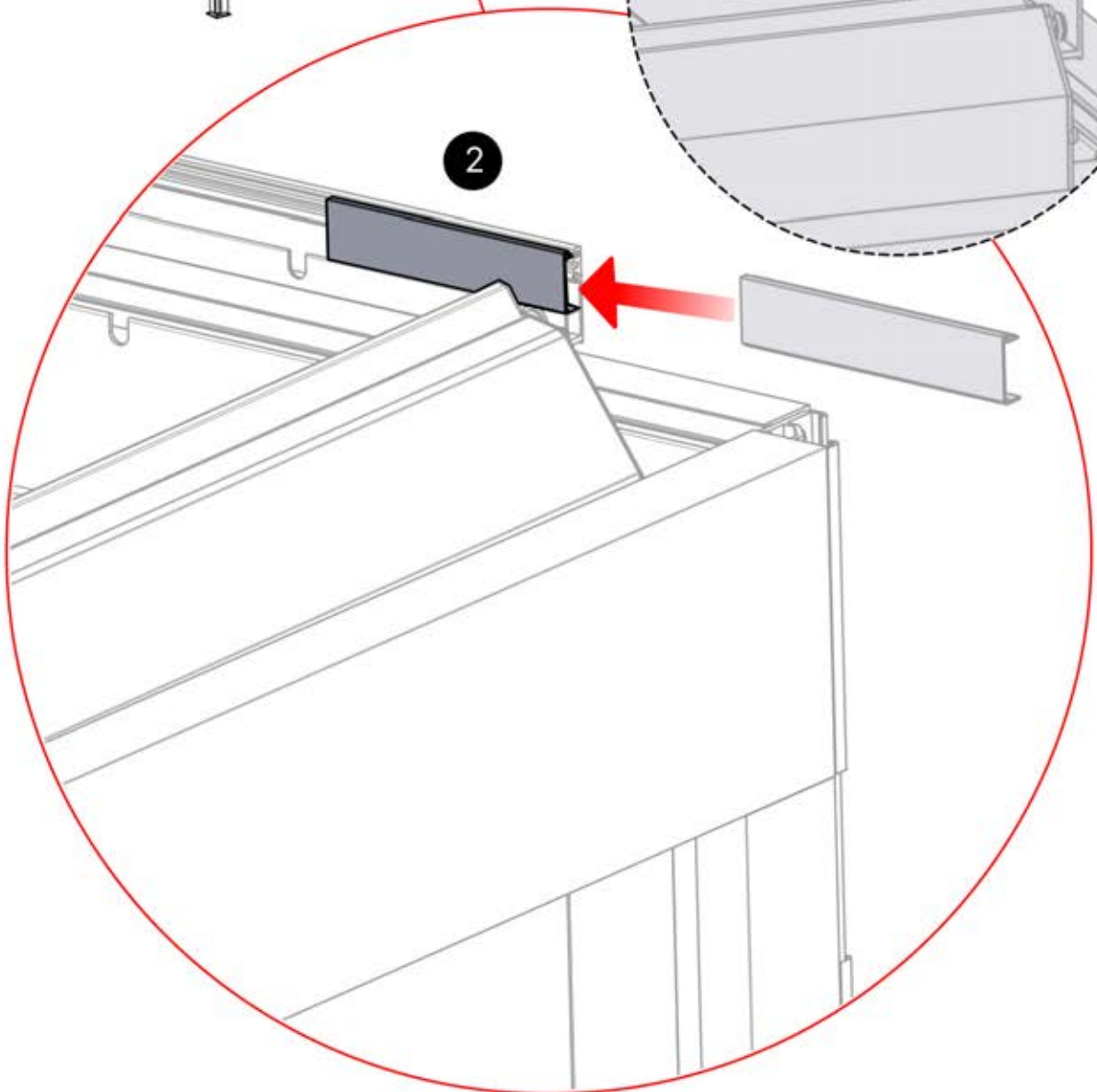
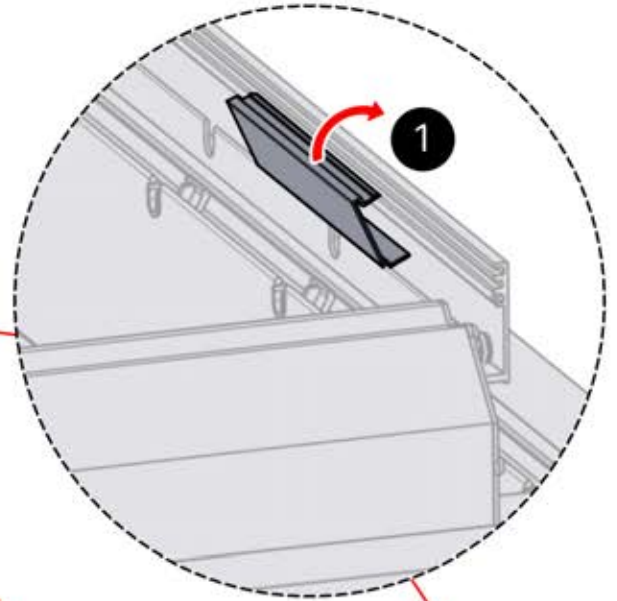
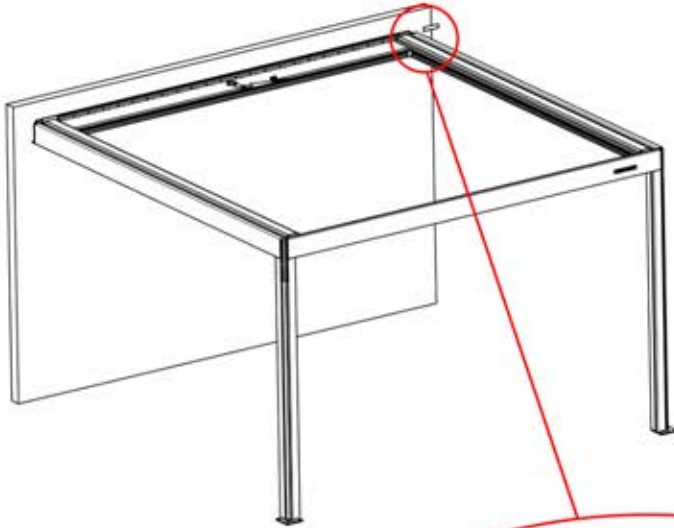
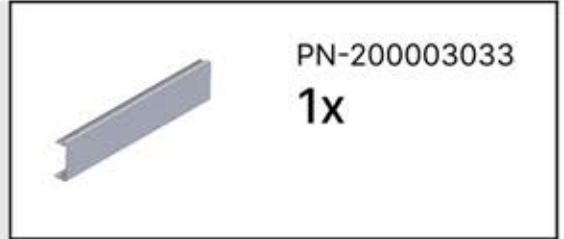

53

x1
PERGOLUX

3

ANTHRACITE: L234
BLANC: L238
NOIR: L236

x3
PERGOLUX
PERGOLUX
PERGOLUX

2

ANTHRACITE: L222
BLANC: L226
NOIR: L224



PN-200002883
23x

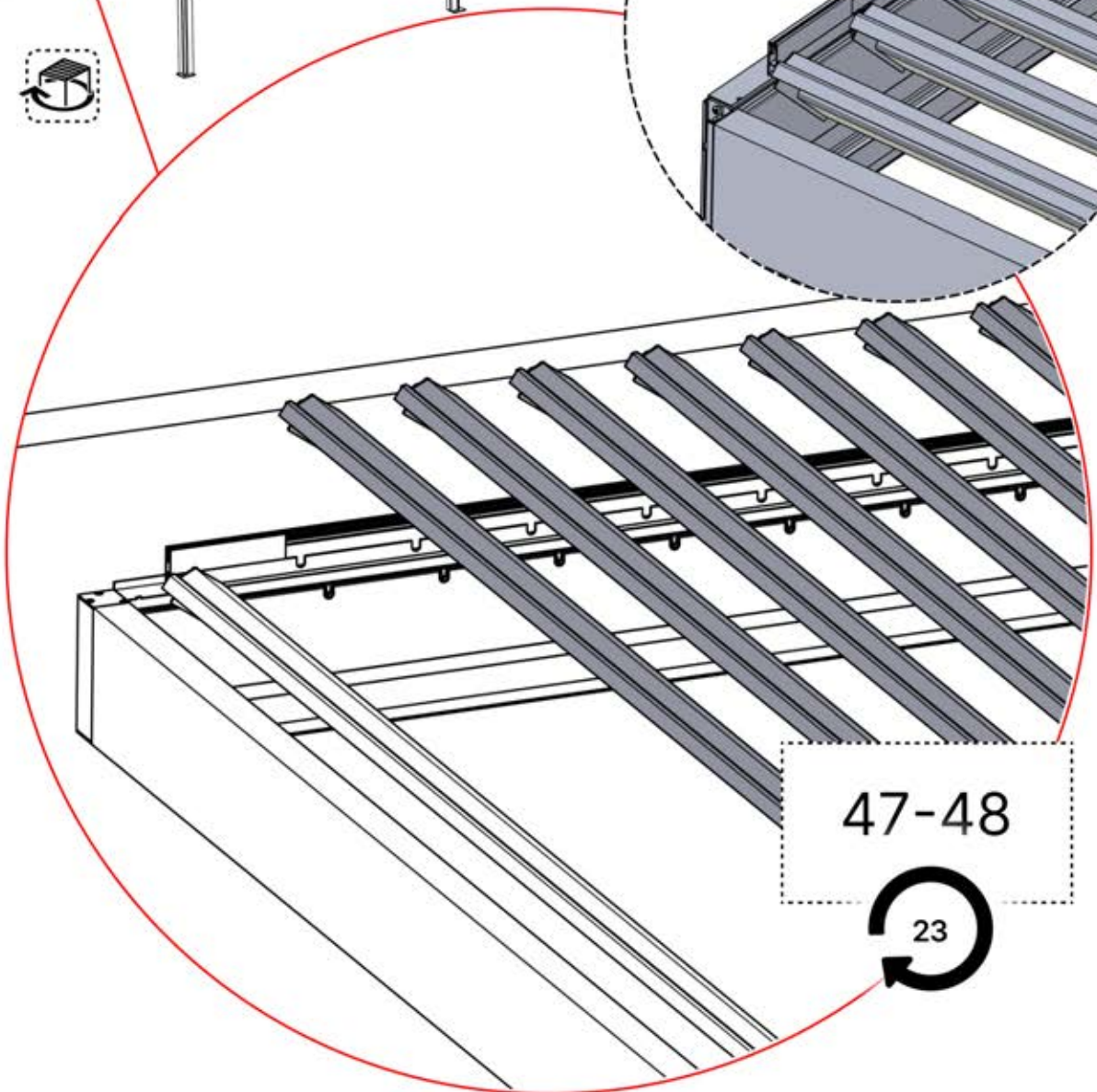
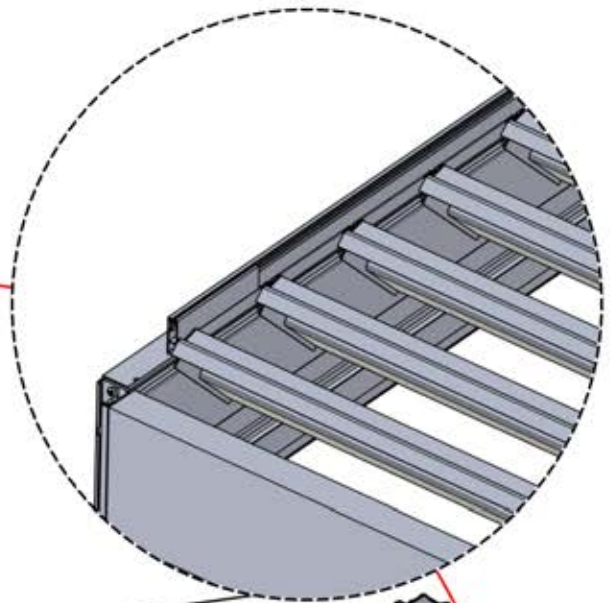

47-48



54



4

ANTHRACITE: B245
BLANC: B253
NOIR: B249

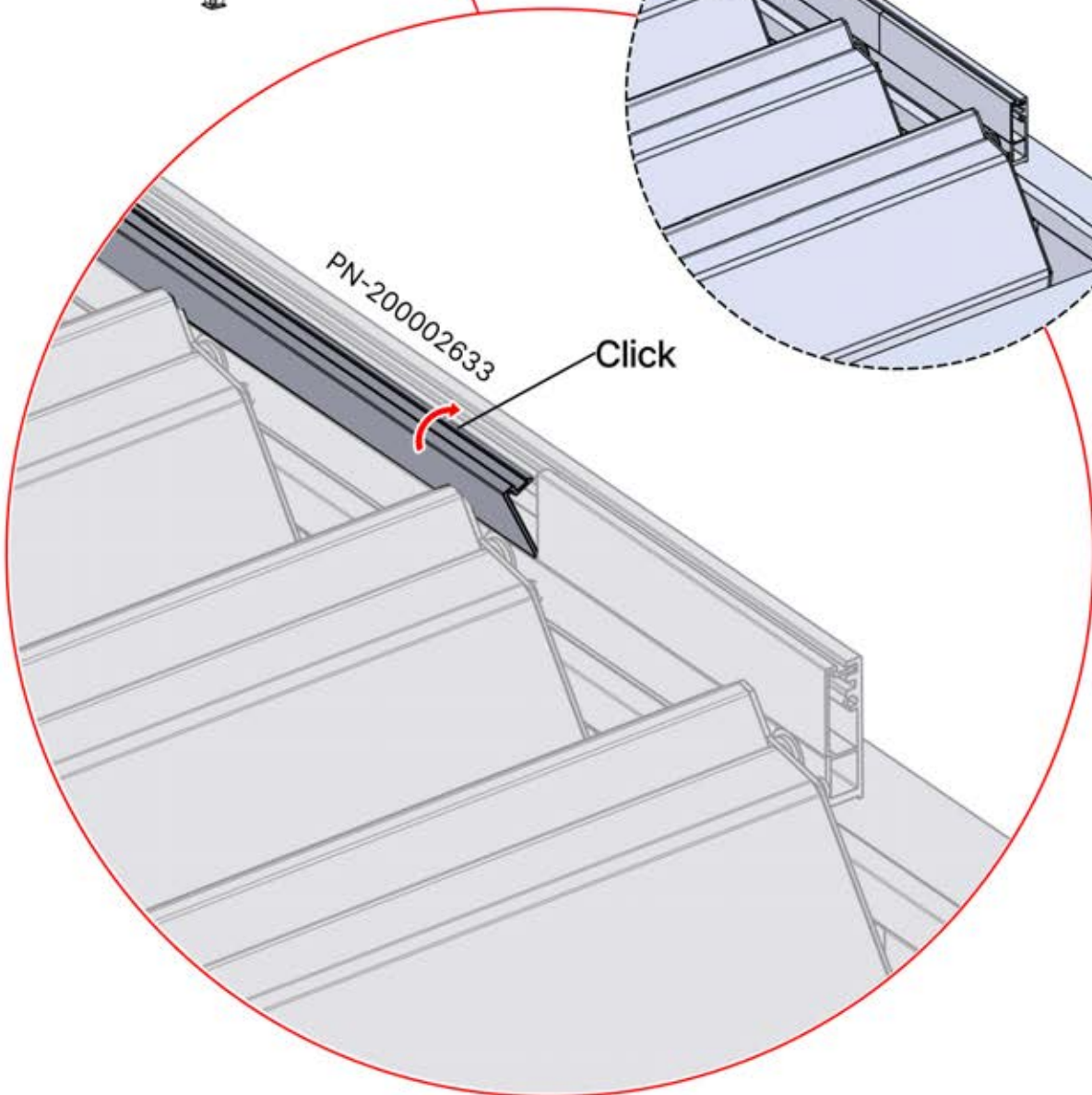
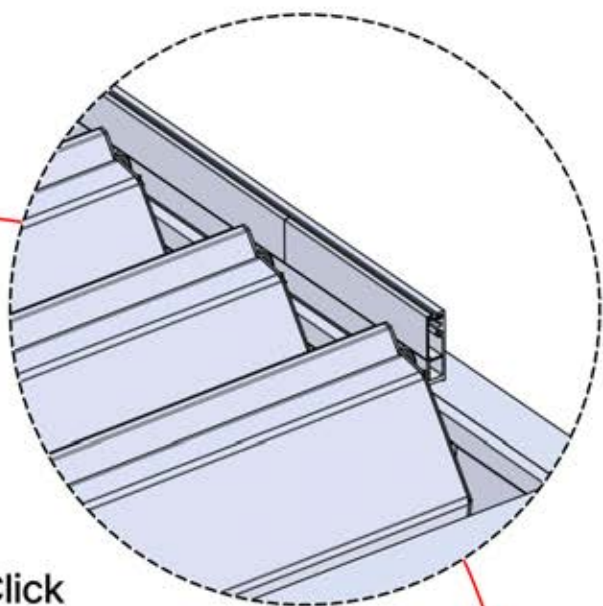
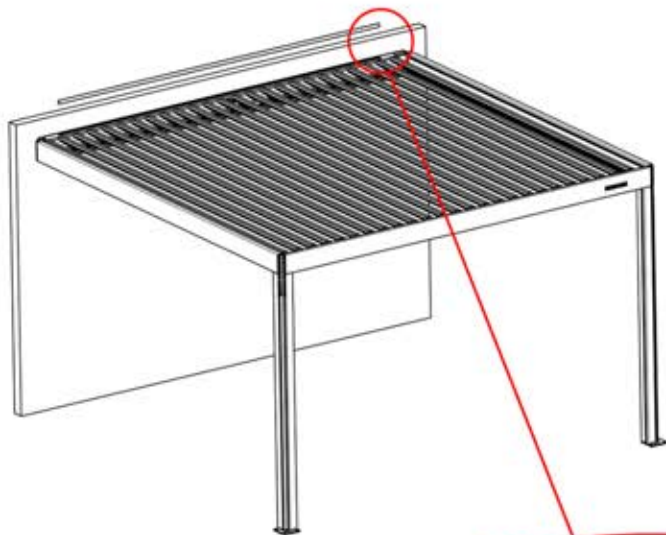
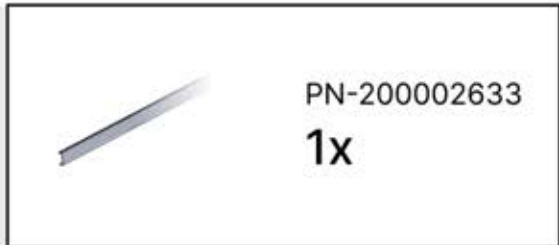

55



4

ANTHRACITE: B245
BLANC: B253
NOIR: B249

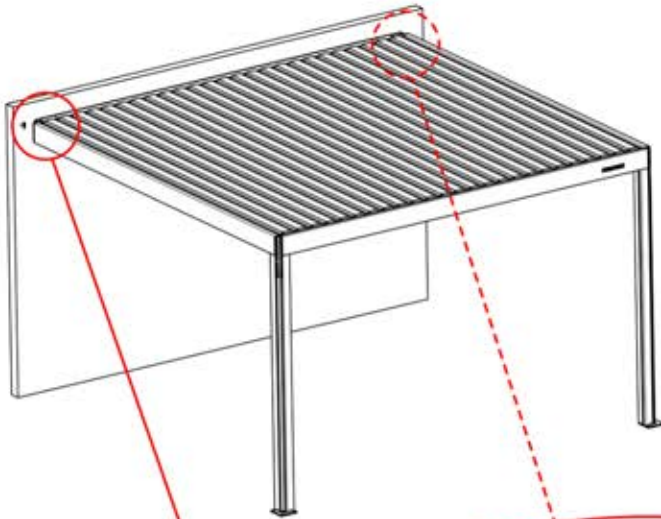

PN-200003030
1x



PN-200003031
1x



PN-200001207
1x

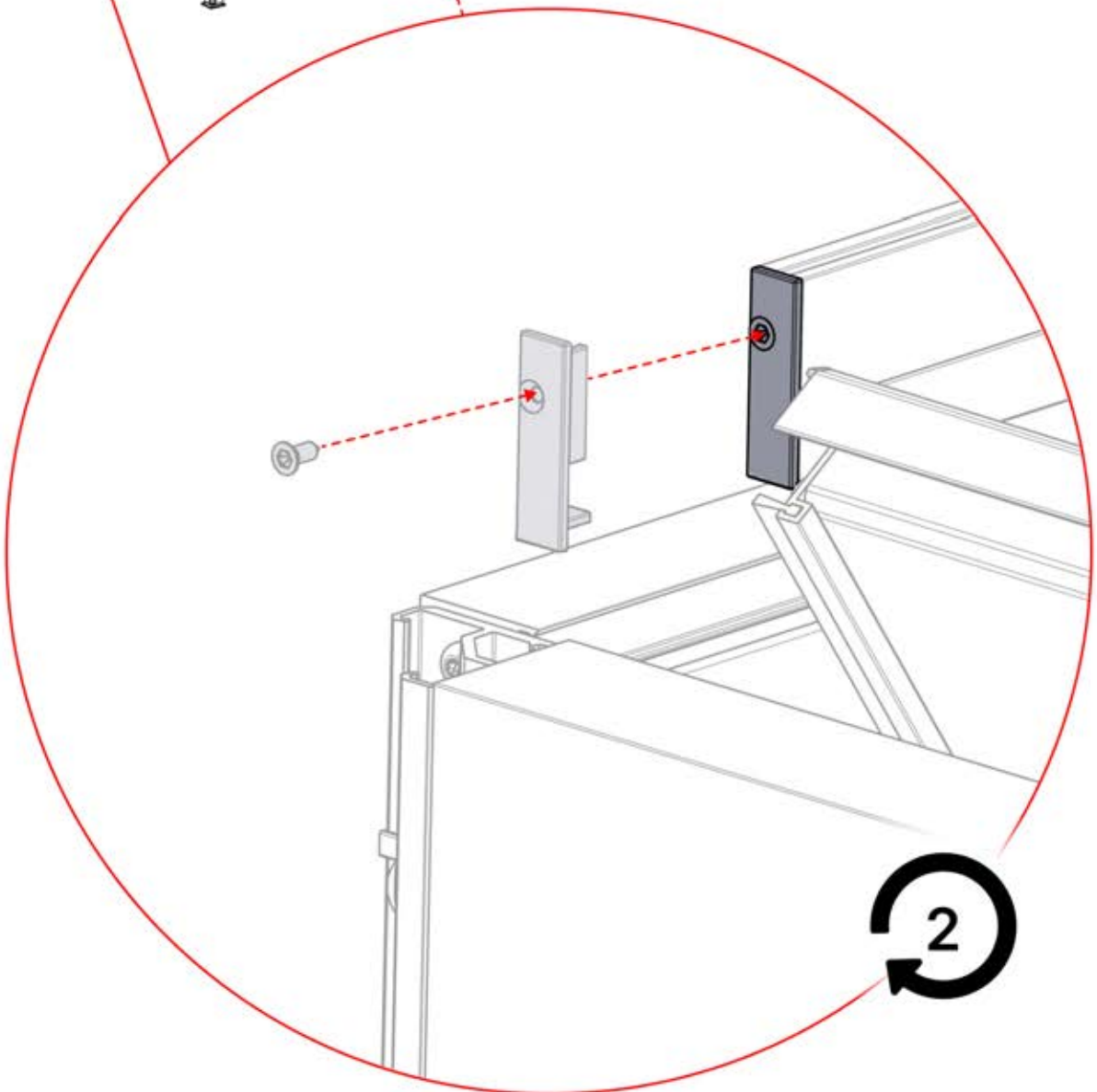

56



4

ANTHRACITE: B245
BLANC: B253
NOIR: B249

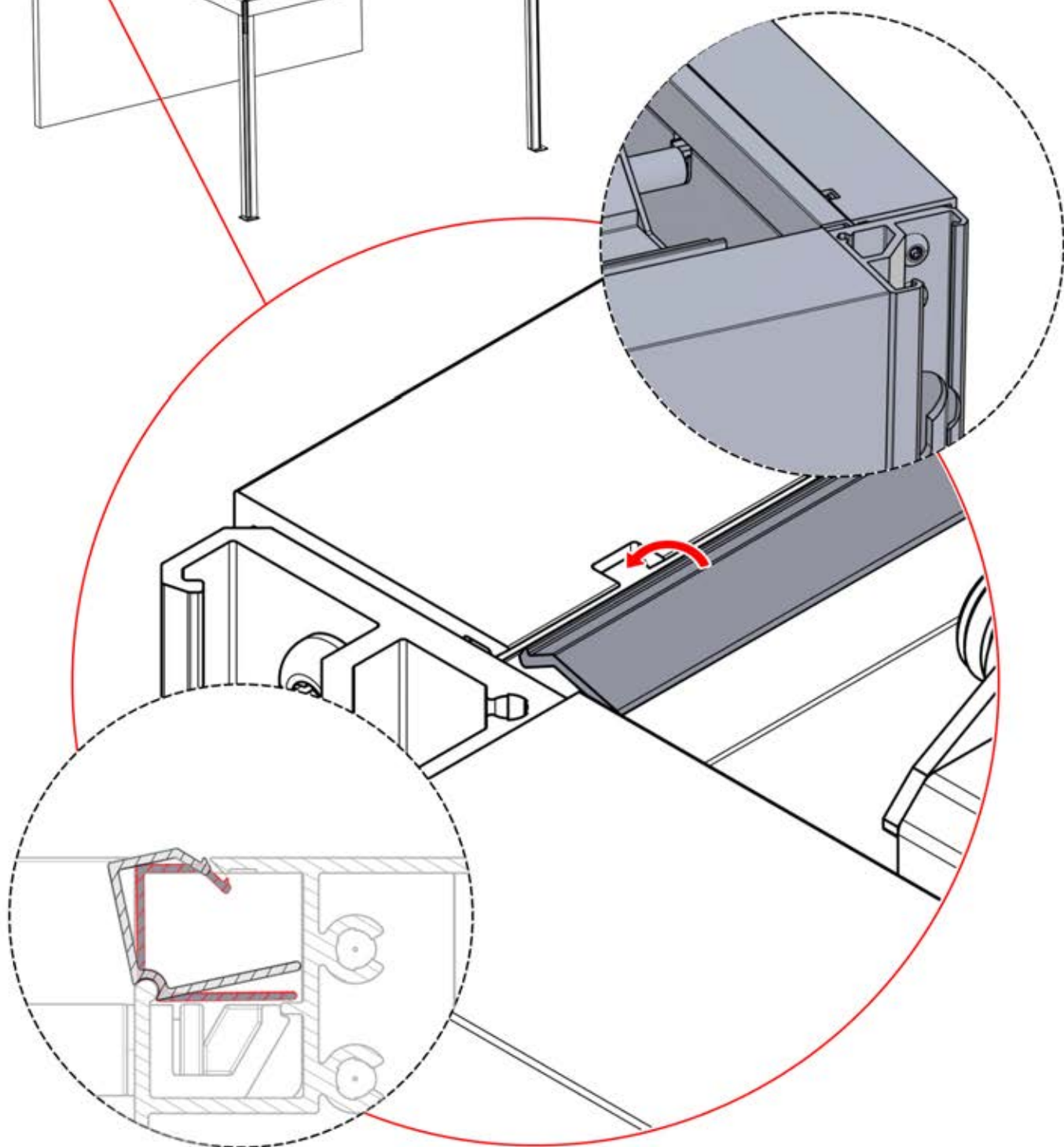
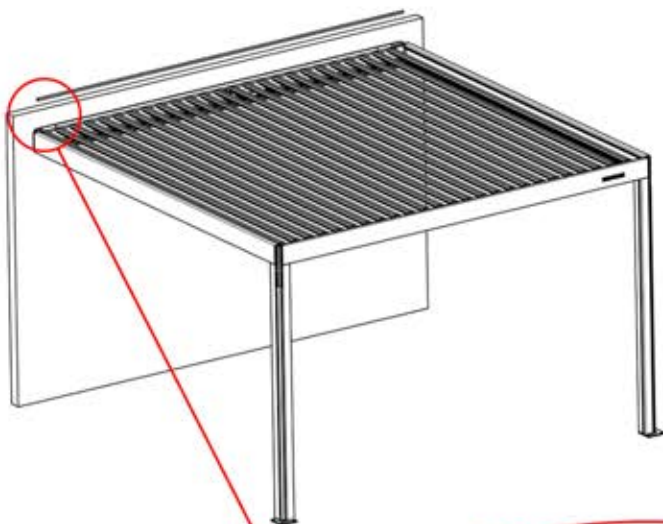
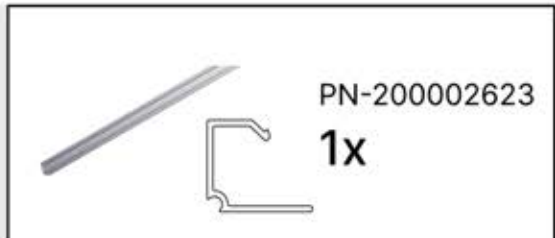

57



4

ANTHRACITE: B245
BLANC: B253
NOIR: B249

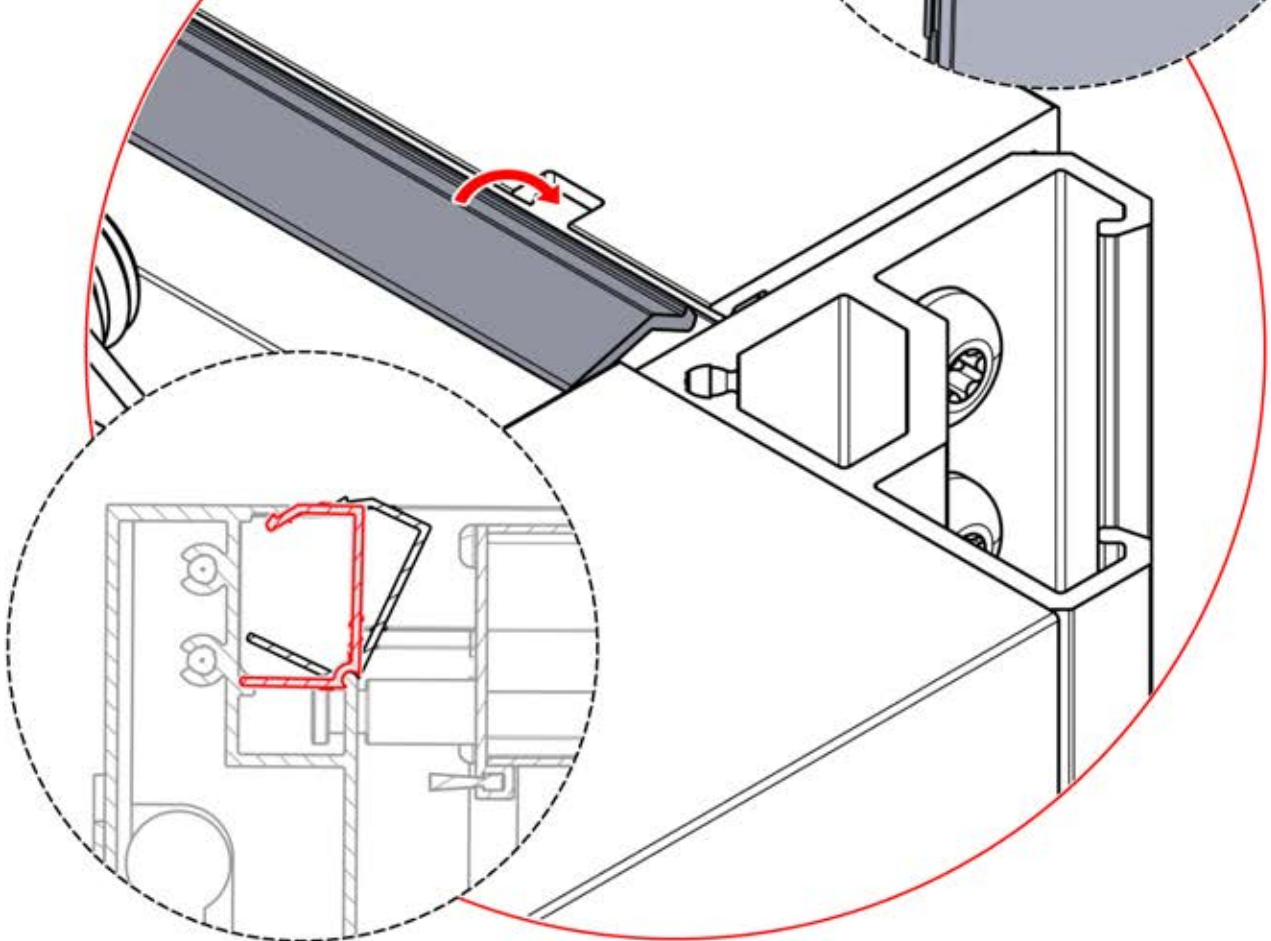
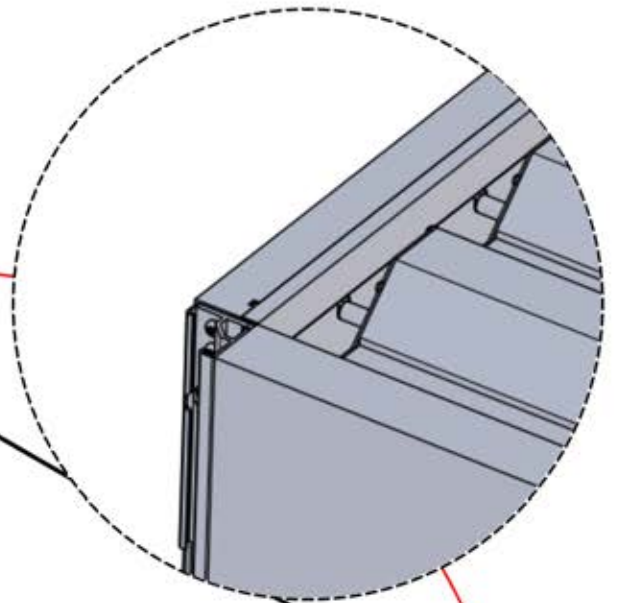
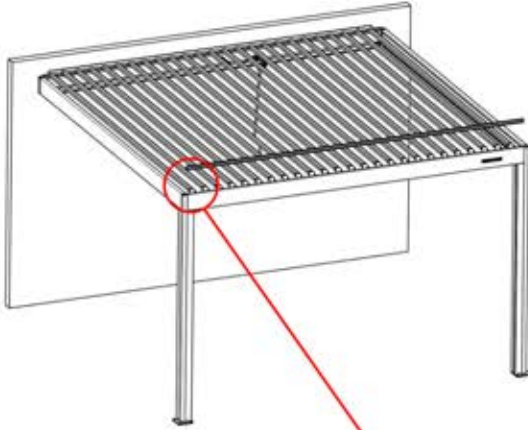
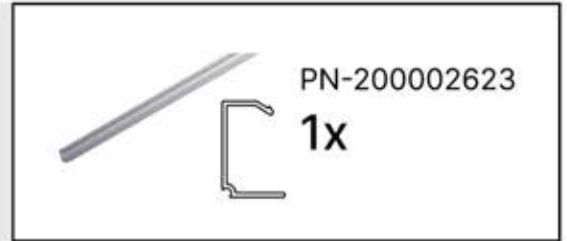

58

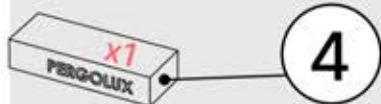

ANTHRACITE: B245
BLANC: B253
NOIR: B249



ANTHRACITE: C120
BLANC: C122
NOIR: C121

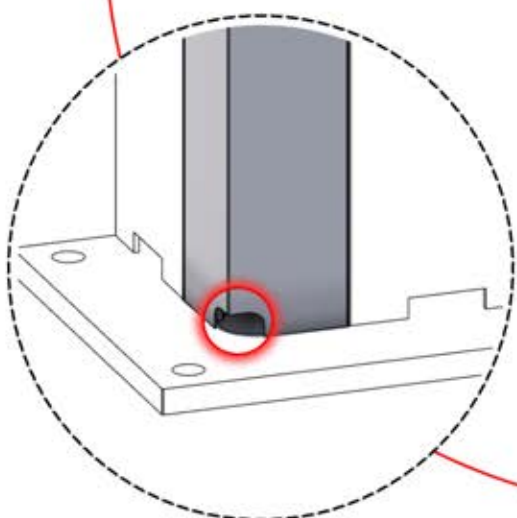
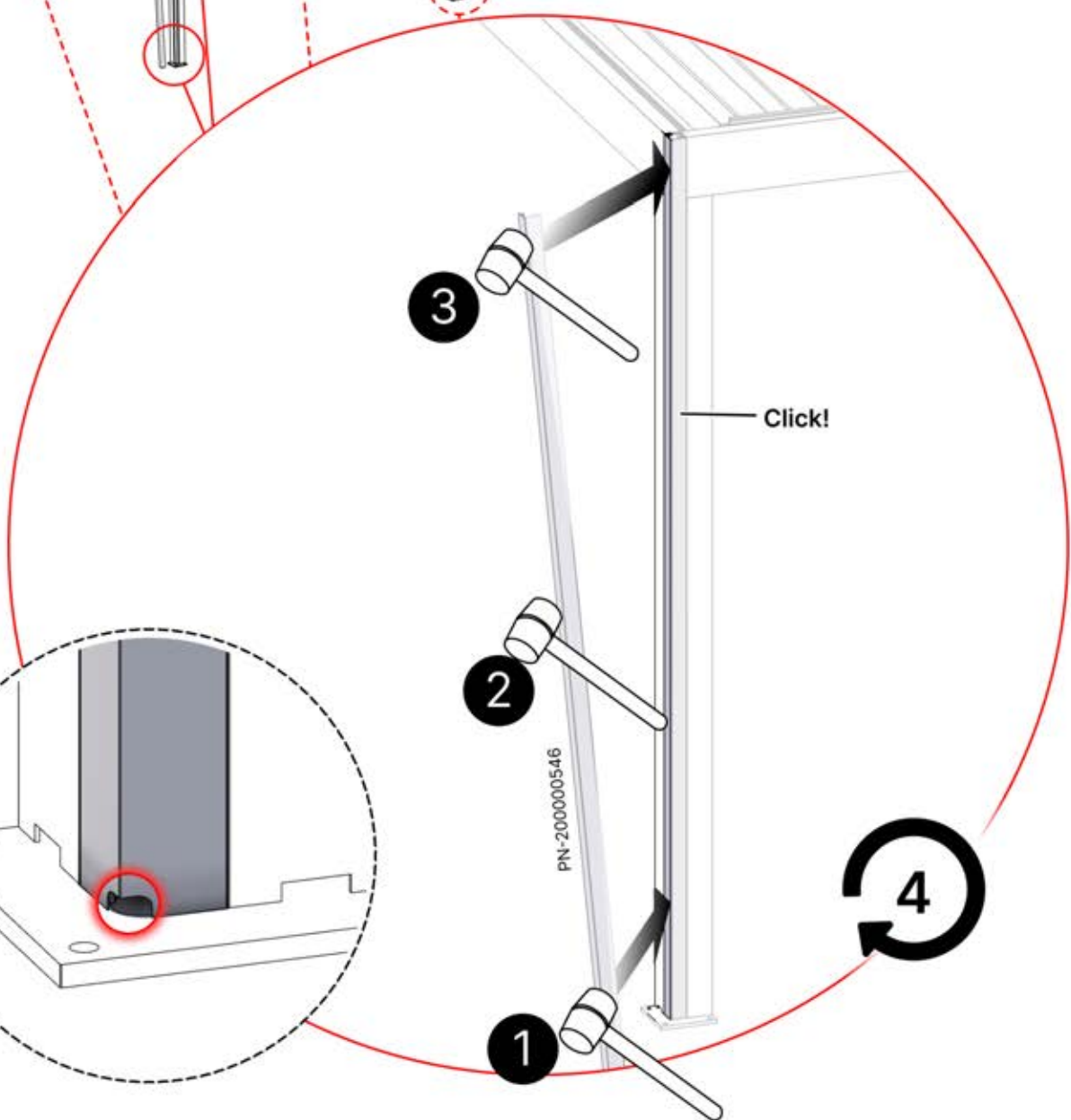
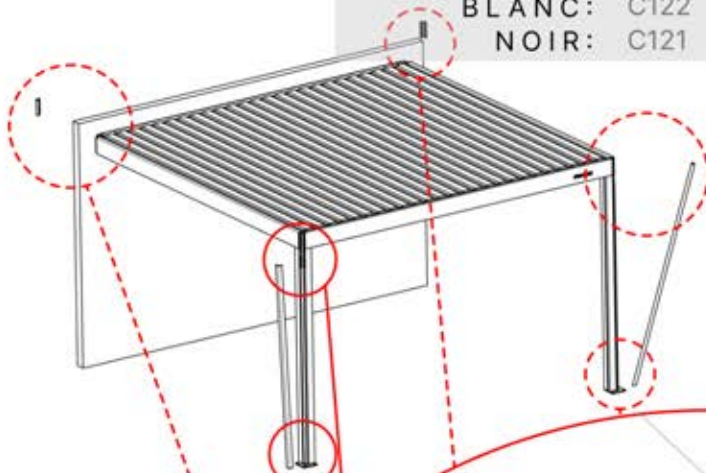

59



4

ANTHRACITE: B245
BLANC: B253
NOIR: B249



PN-200001514
4x



PN-200003323
2x



PN-200003322
2x



PN-200000840
18x

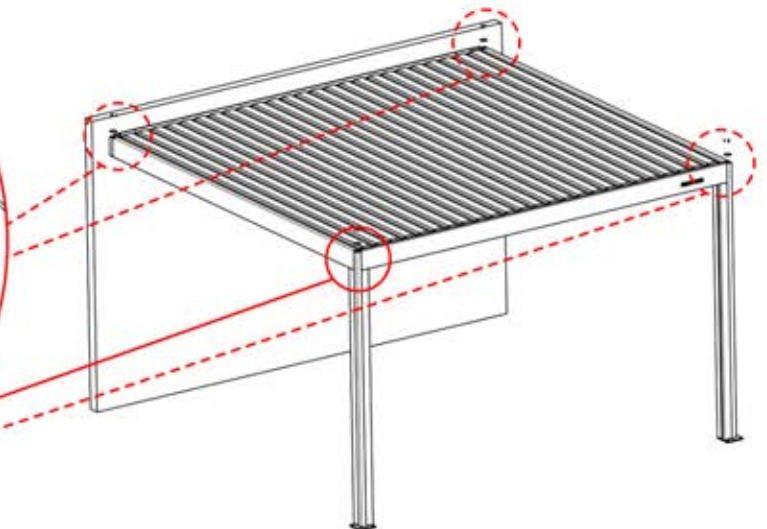
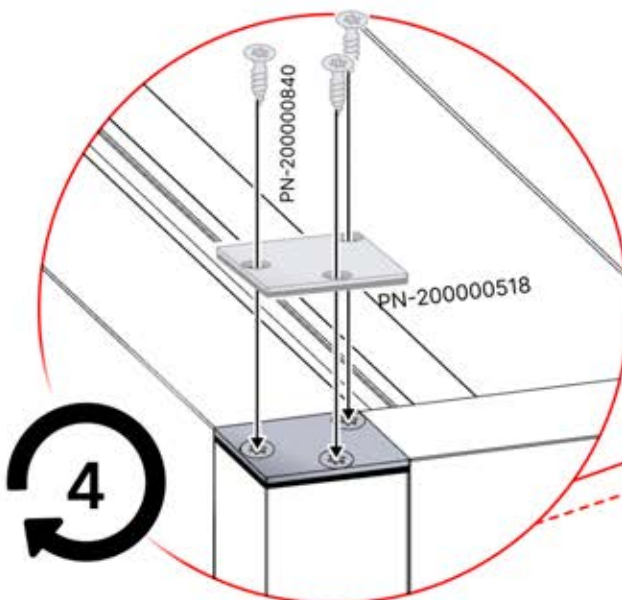
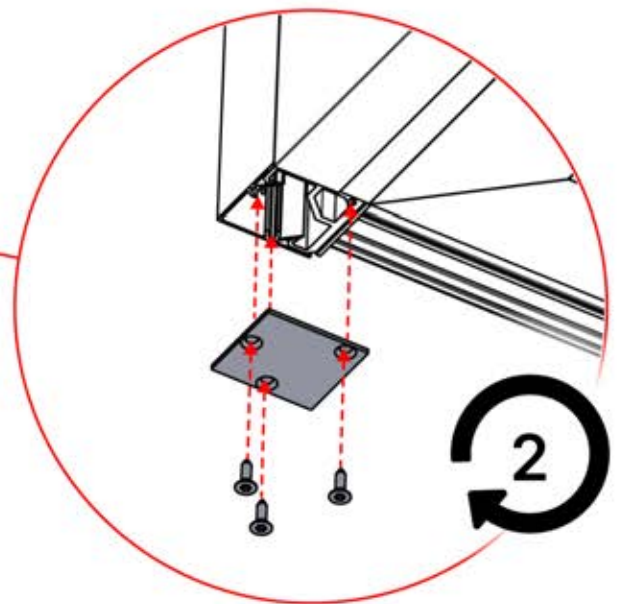
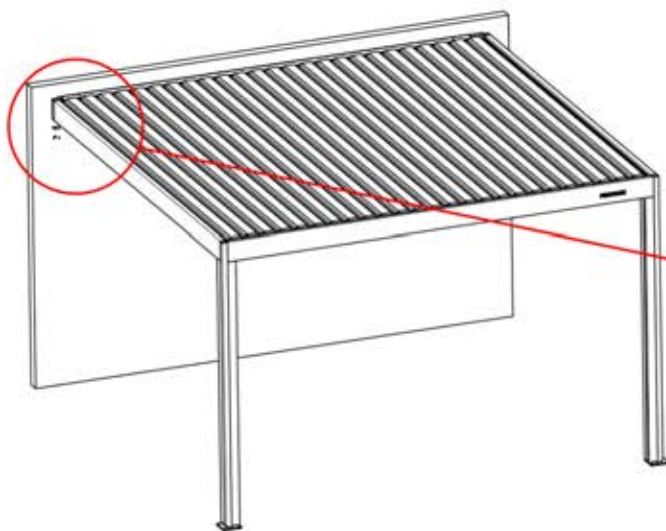

60

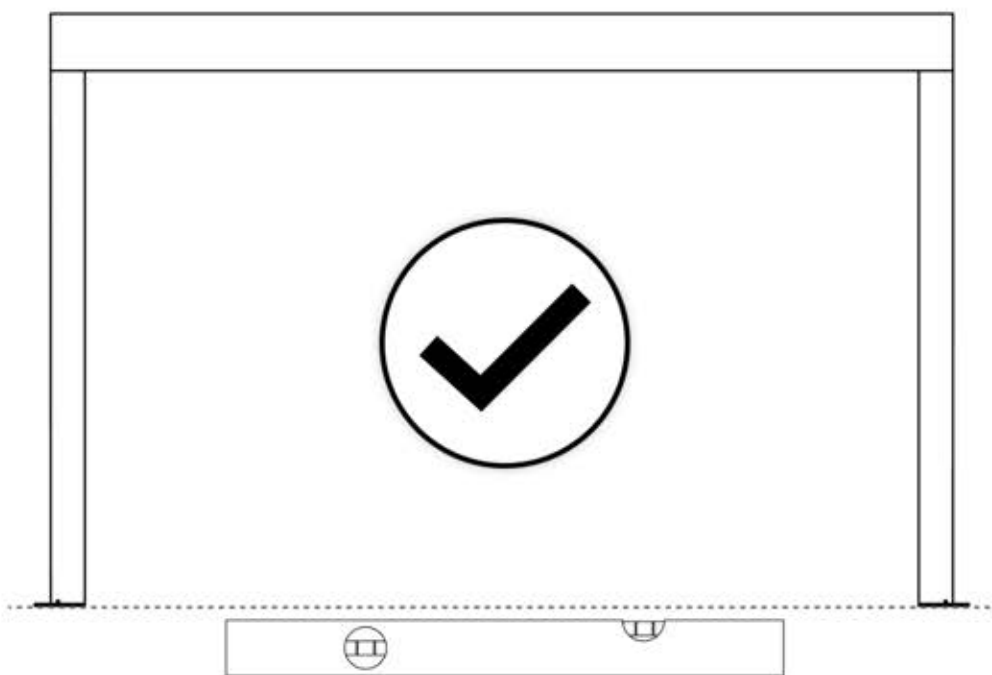
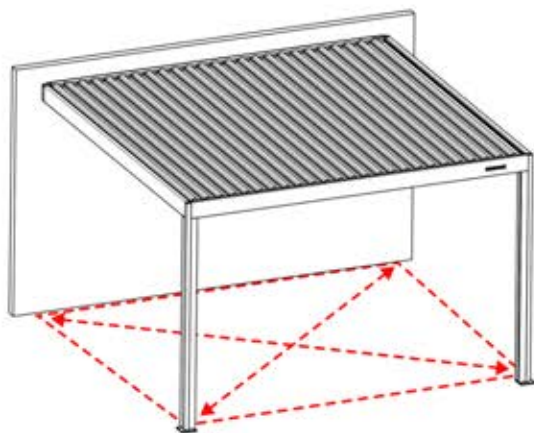
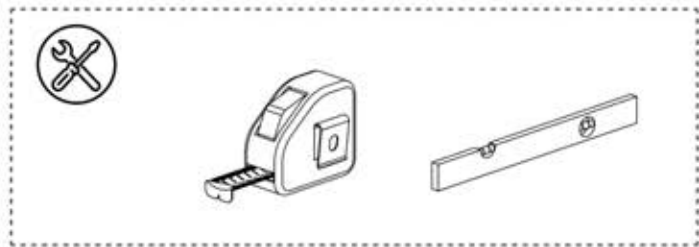

61



4

ANTHRACITE: B245
BLANC: B253
NOIR: B249

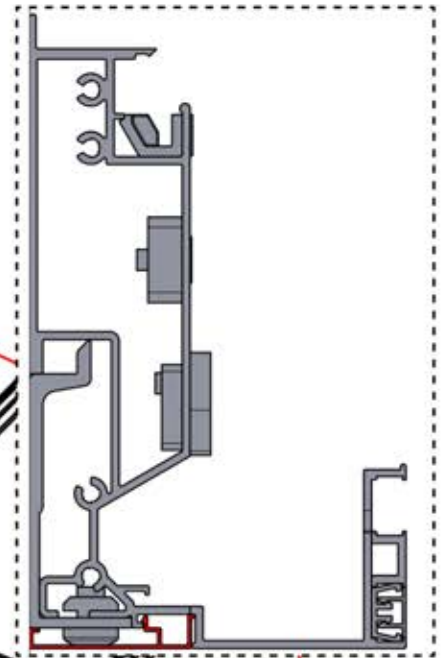
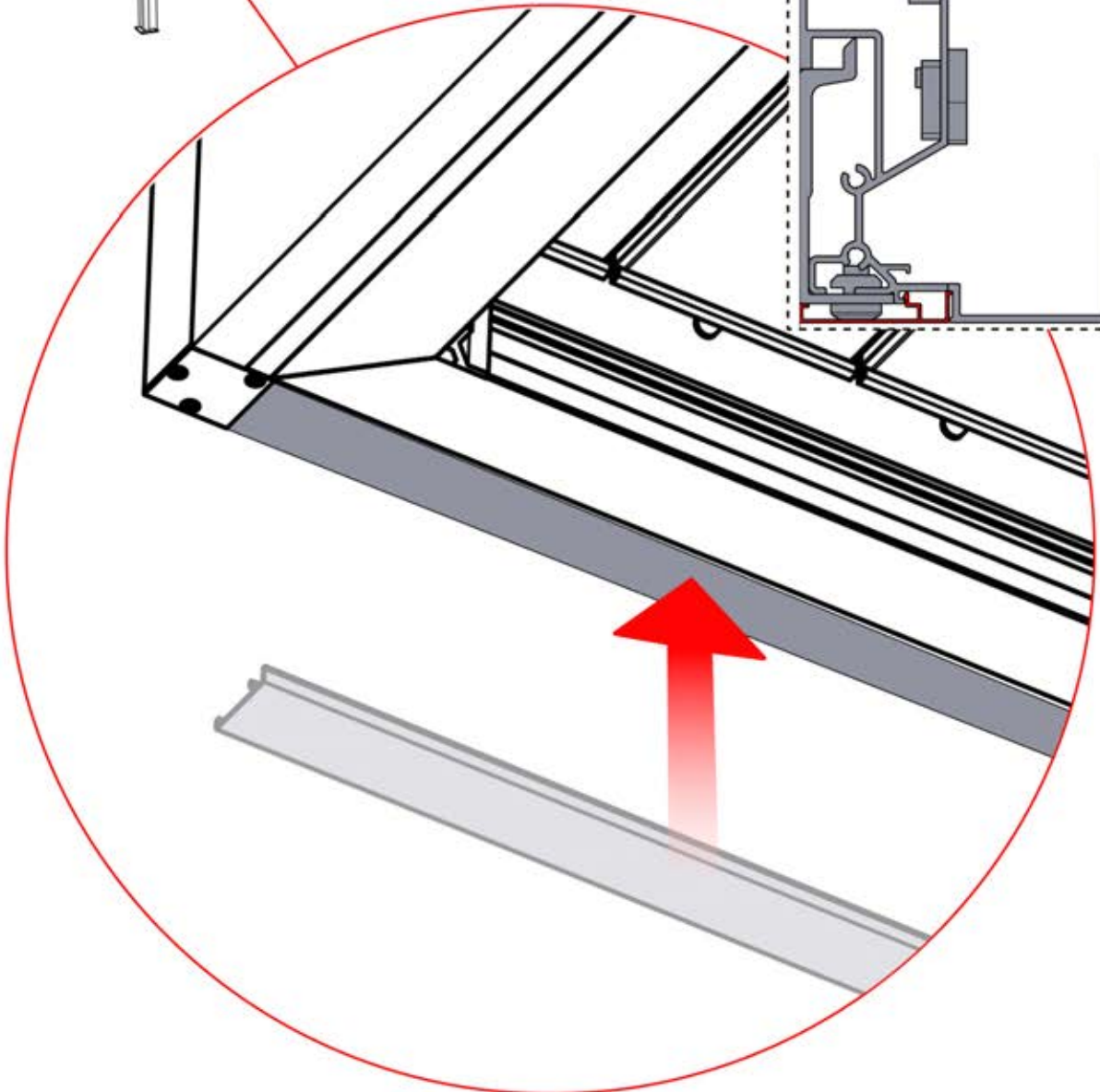
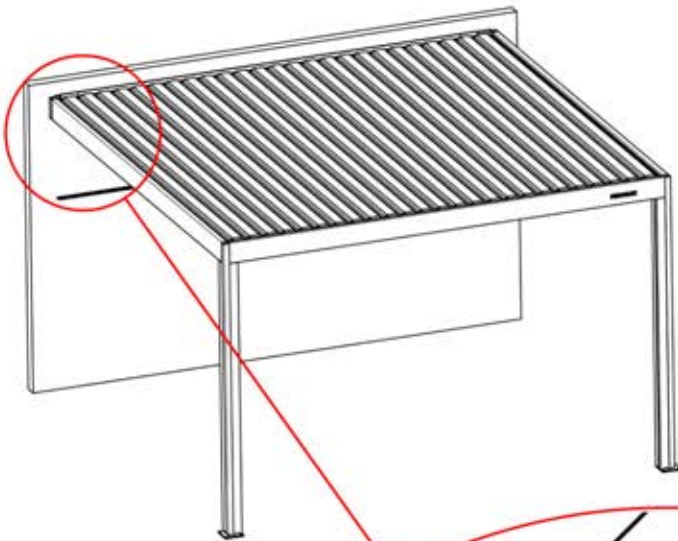
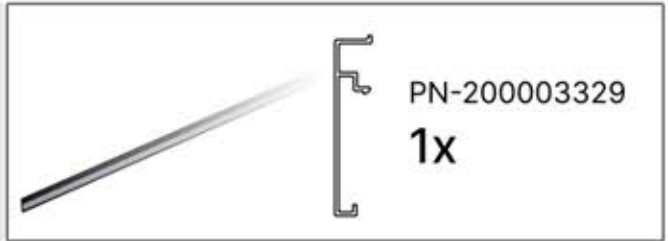

62

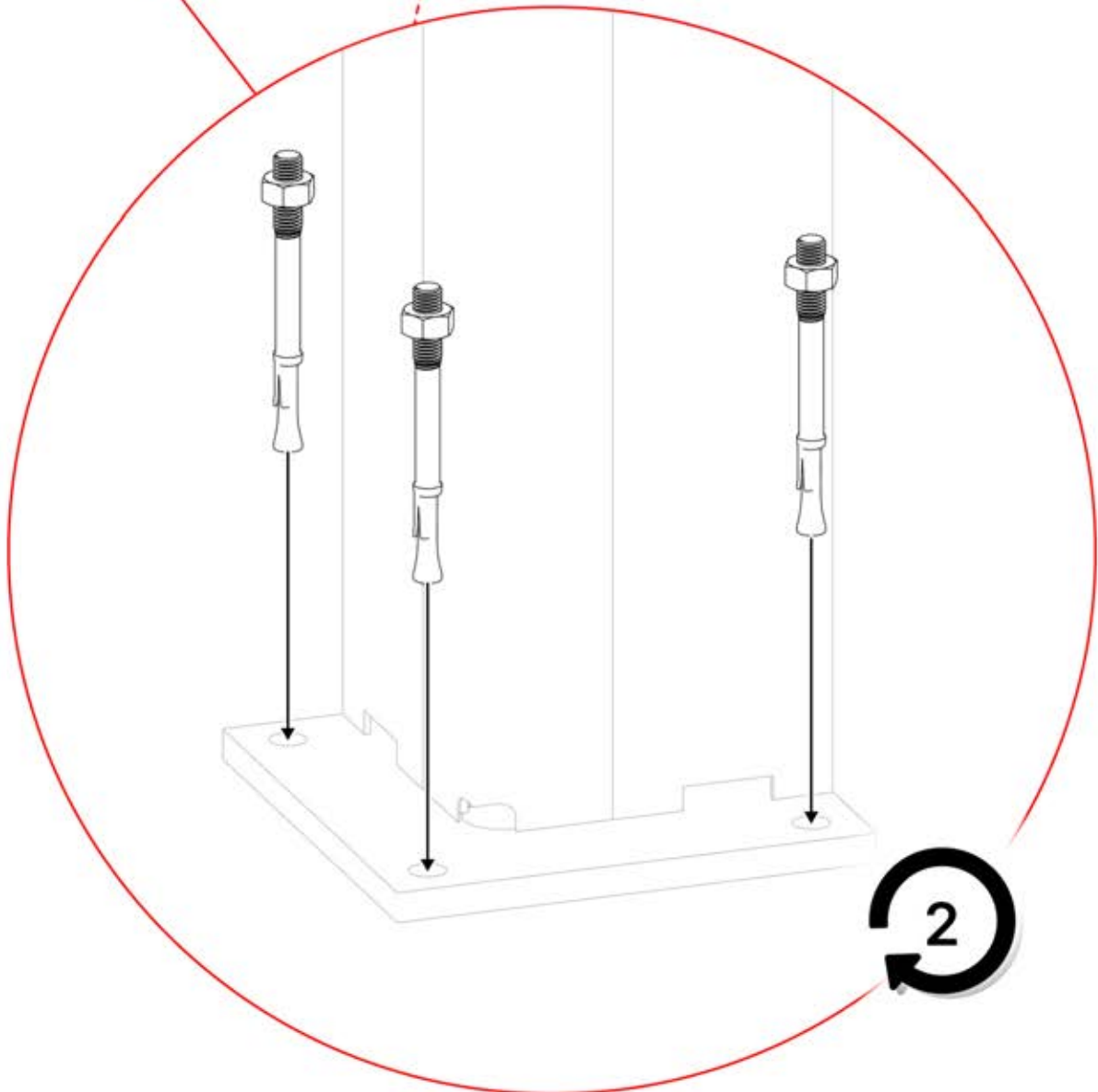
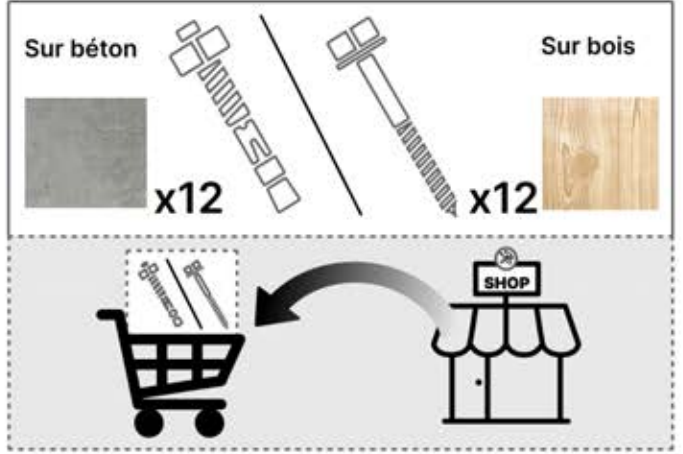
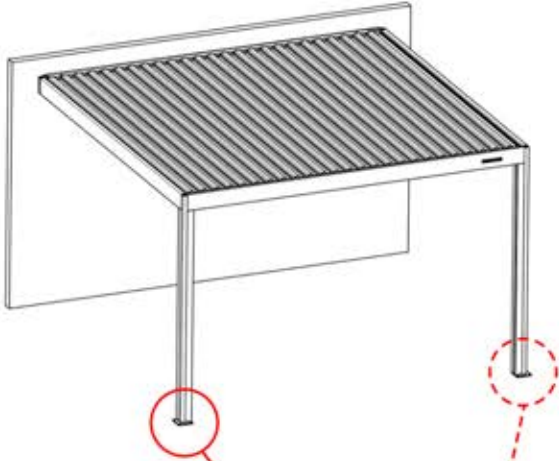

PERGOLUX | PERGOLA PRO AUTOPORTÉE

S4

4 X 4 M / 13' x 13'

