



PROBLEM SOLVER MACHINE VISION POWERSTATION

EMPOWERING MOBILITY

The Ultimate Mobile Scanning Solution for Warehouse Quality Operations

Unlock next-level automation and accuracy with the **DTG Problem Solver Machine Vision PowerStation**, a revolutionary mobile workstation designed to elevate warehouse quality operations to the next level. Engineered with Zebra's advanced Machine Vision (MV) cameras, AI-powered software, and a high-performance computing system, this powerful solution ensures precise identification and processing of products, packaging, and more.

Maximize Speed & Accuracy

- Automate scanning to capture barcodes, lot numbers, expiration dates, and sale dates in a single scan.
- Improve warehouse productivity by minimizing manual errors and streamlining operations.

Enhanced Quality Control & Inspection

- Utilize Zebra's AI-driven Machine Vision to detect defects and inconsistencies undetectable to the human eye.
- Prevent costly mistakes by instantly identifying and correcting labeling or packaging errors.
- Reduce chargebacks from retailers by complying with strict quality and barcoding requirements.



Problem Solver
Machine Vision PowerStation

100% Battery-Powered & Mobile

- Work anywhere with a fully mobile workstation that supports picking, packing, and fulfillment operations.
- Powered by long-lasting **Lithium Iron Phosphate (LFP)** batteries, ensuring a full shift of uninterrupted performance without risk of fire or explosion.



*Streamline Productivity with DTG's Mobile
Machine Vision PowerStations!*

PROBLEM SOLVER MACHINE VISION POWERSTATION

By combining Zebra's advanced scanning technology with mobility, the DTG Problem Solver Machine Vision PowerStation eliminates inefficiencies, reduces chargebacks, and boosts warehouse productivity. Bring the operator directly to the point of task for real-time visibility, faster issue resolution, and smarter automation.

Specifications

- Battery System: MPower X600
- Type: Swappable
- Chemistry: Lithium Iron Phosphate (LFP)
- Capacity: 600 Wh (2 x 300 Wh Batteries)
- Output: 120 W (Cont.) / 150 W (Peak)
- Recharge Time: 2-3 Hours
- Cart Dimensions: 78" H x 26" D x 18" W
- Cart Worksurface: 18" W x 25" D
- Cart Weight: 220 lbs

Features

- Made from powder-coated steel with thermofoil laminated surfaces for harsh environments
- AC power cord allows workstation to be charged directly on the unit or via externally mounted charging station (sold separately)
- Adjustable camera mount extrusion for Zebra VC40 Machine Vision Camera or equivalent
- Two locking swivel casters in the rear and two directional locking swivel casters in the front
- Lockable technology tray at the PowerStation's base
- 5-Year Warranty for cart, power system, and battery cells

Options

- Height Adjustable Worksurface: 18" W x 25" D with front-facing handles and weight capacity of 75 lbs
- Several other accessories/options are available. Contact DTG to learn more.

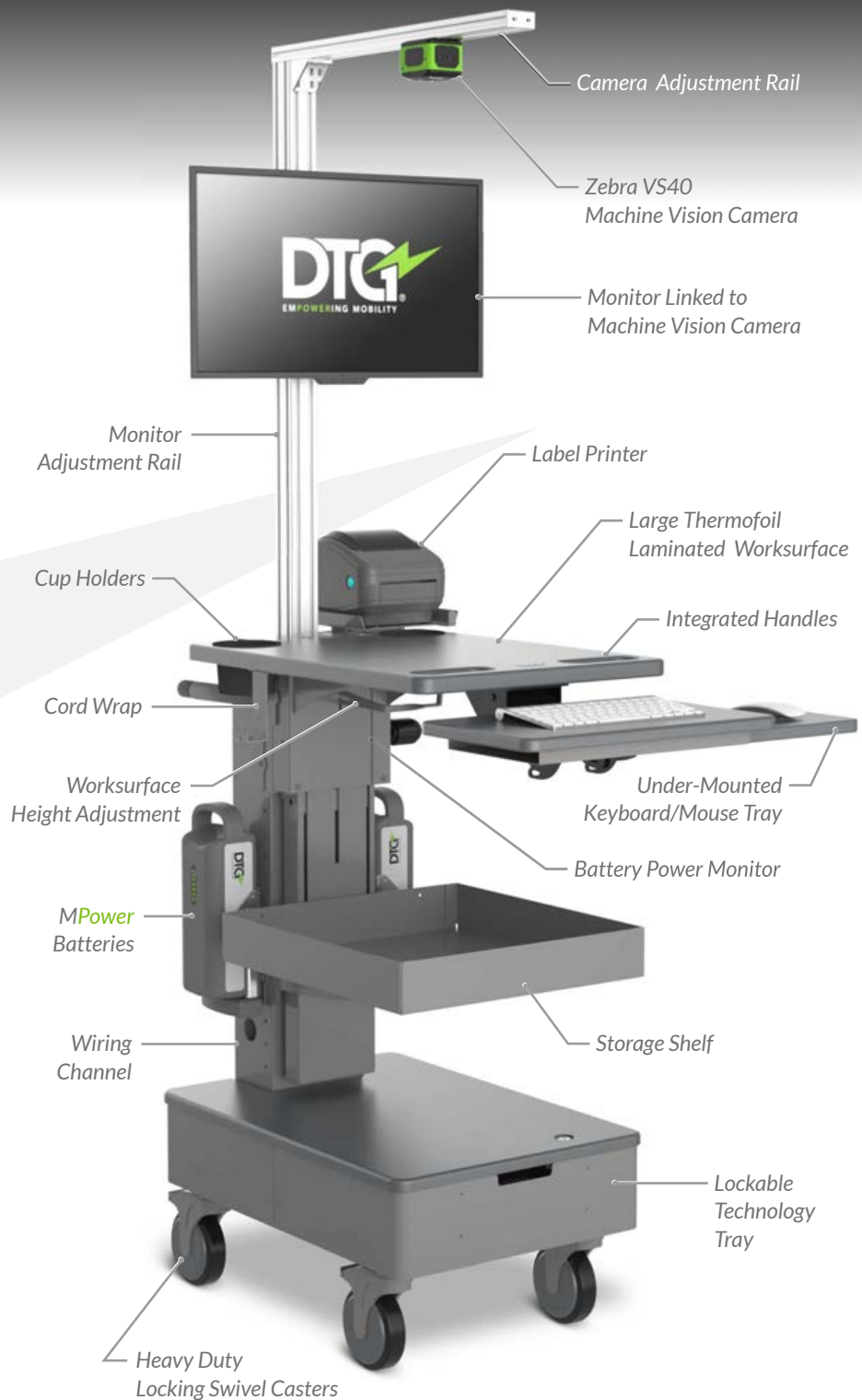

REQUEST A DEMO TODAY!

1.3-260320

DTG  
35 Upton Dr, Wilmington, MA 01887

(978) 532-0444 | Sales@DTGPower.com | www.DTGPower.com

