

SBE-STD-CB-1

Battery Pack

The Battery Pack is an optional accessory designed to extend the operating life of Move Solutions sensors.



KEY FEATURES



For indoor and outdoor operation



Extends battery life of Move Solutions sensors



Quick, flexible, and easy installation



Plug-and-play connection to Move Solutions sensors through provided cable



Based on high-density, non-rechargeable, user-replaceable lithium batteries.

Device operation

The Battery Pack is supplied pre-activated and ready for use with sensors equipped with Move Link connector. Prior to installation, refer to the sensor datasheet and/or user manual to verify compatibility with the Battery Pack.

User access to the internal components is not required during installation. The enclosure should only be opened for battery replacement.

When connected to a compatible Move Solutions sensor, the Battery Pack begins supplying power automatically. No configuration is required. The connection status is indicated by audible notifications as follows:

- **Connection established:** one long beep.
- **Connection lost:** five short beeps in sequence.

NOTE

If the Battery Pack is disconnected from the sensor, wait at least 15 seconds before reconnecting. Otherwise, the device will operate correctly but the connection confirmation sound will not be generated.

Battery life

The extended battery life is achieved by combining the sensor's internal batteries with the Battery Pack. Expected values for the combined operating time are provided in the sensor datasheet and depend on the sensor's product code, its configuration, and operating conditions.

Technical specifications

GENERAL DATA

Connections	Embedded, non-removable cable with Move Solutions 8-pole connector Move Link. Requires Move Solutions sensors provided with 8-pole Move Link connector.
IP rating ¹	IP67
Internal batteries	4x 19Ah 3.6V replaceable lithium battery (D-type LiSOC12 with JST EHR-2 connector, suggested EVE ER34615 EHR2)
Operating temperature range	From -40 °C to +85 °C
Dimensions	194.5 x 136.5 x 63 mm
Weight ²	0.9 kg
Package weight	1 kg
Case material	Polycarbonate
Included cable	Non-removable, 40 cm length
Installation options	Wall, floor, or ceiling mount using screw anchors (Ø6mm max). One set included in the package.

¹ The declared IP rating applies only when the lid is correctly screwed in place and the cable is connected to a compatible Move Solutions sensor.

² Refers to the Battery Pack unit itself. External accessories, such as mounting hardware, are not considered since they are optional and/or can be replaced with alternative parts to fit specific applications.

ORDERING INFORMATION

DEVICE	PART NUMBER
Battery Pack	SBE-STD-CB-1

Mechanical drawings

All dimensions are in millimeters

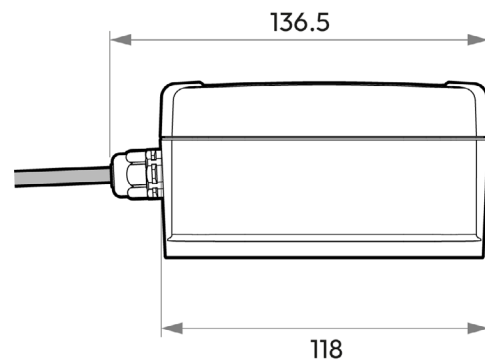
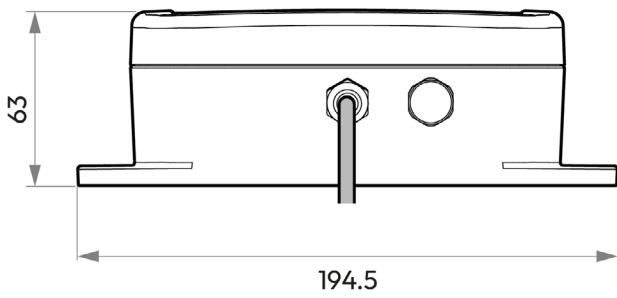
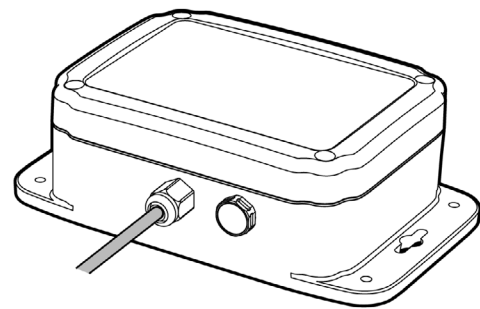
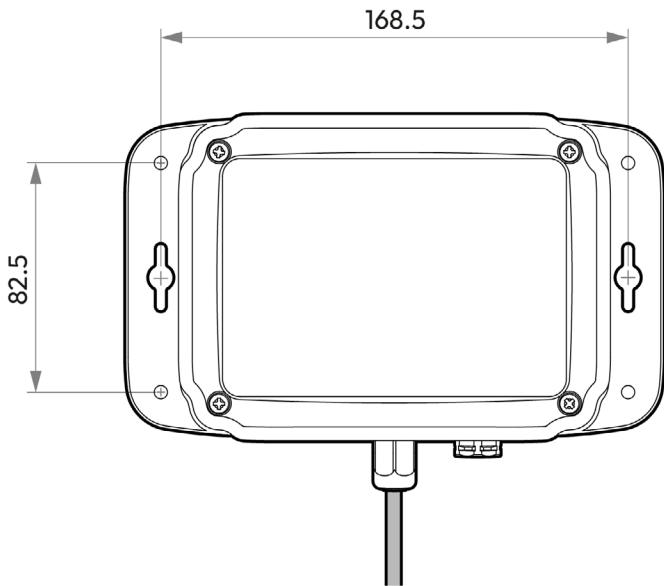

For complete information regarding proper use of the device, safety precautions, installation, operation, and maintenance requirements, users must refer to the official product manual.

DOCUMENT REVISIONS

N°	DATE	NOTES
REV. 1	14 April 2026	Initial release

Notice of publication

The information contained in this document may be subject to change without notification. For more detailed information, product specifications and to download up-to-date documents, visit our website at www.movesolutions.it.