

HeartFocus

Computer-assisted echocardiography acquisition software

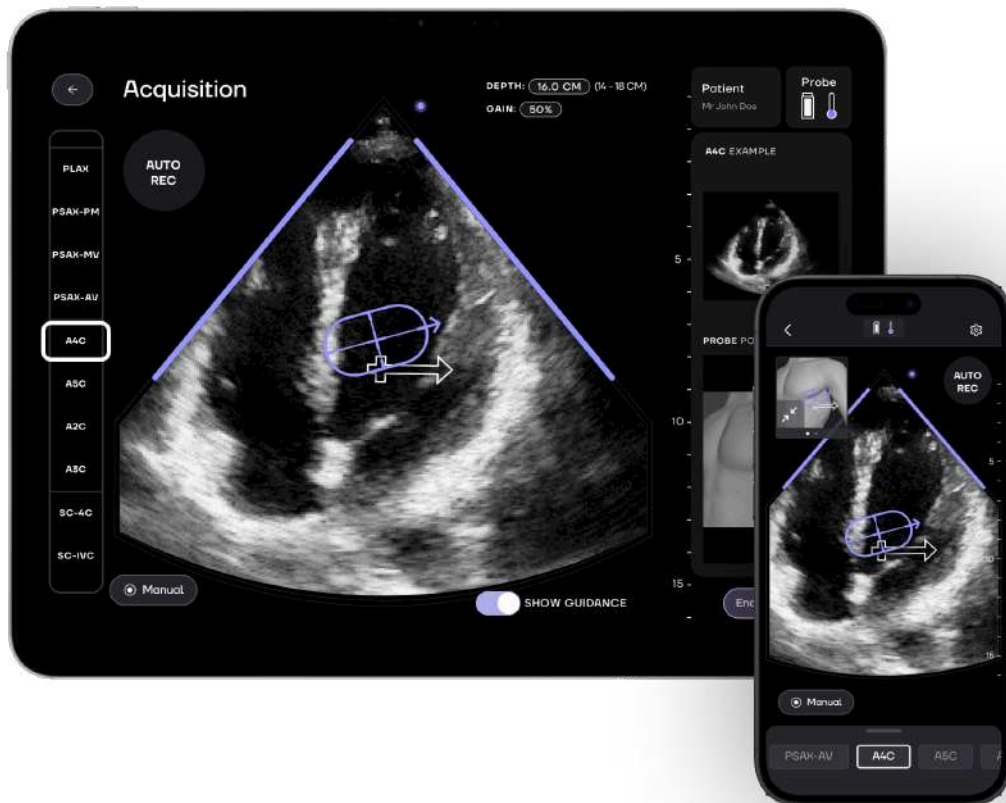

User manual

Copyright © 2021-2026, DESKi SAS. All rights reserved.

This User Manual is provided to HeartFocus software customers to support safe use and compliance with 21 CFR 892.2050 and applicable regulations.

No part of this document may be reproduced, copied in whole or in part, adapted, modified, or transmitted in any form or by any means, electronic, mechanical, photo reproductive, recording, or otherwise, without the prior written permission of DESKi SAS.

DESKi SAS has taken care to ensure the accuracy of this document. Nevertheless, DESKi SAS assumes no responsibility for errors or omissions and reserves the right to make changes without further notice to any products and accompanying technical information.

All intellectual property rights, including those created by patent grant or registration of a utility model or a design, are expressly reserved. Any unauthorized use is illegal.

© 2026 DESKi SAS All rights reserved. HeartFocus and the HeartFocus logo are registered trademarks of DESKi SAS. DESKi products/services may be covered by one or many patent applications.



DESKi S.A.S

2, Place de la Bourse
33000 BORDEAUX
FRANCE

Email: support@deski.ai

Web: www.heartfocus.ai



CONTENTS

CHAPTER 1 - INTRODUCTION	8
ABOUT THIS MANUAL	8
CONVENTIONS USED IN THIS MANUAL	8
ABBREVIATIONS AND ACRONYMS USED IN THIS MANUAL	9
COMPLIANCE	10
GENERAL DESCRIPTION	10
OPERATING PRINCIPLE	10
INTENDED USE/INDICATIONS FOR USE	11
OTHER TYPES OF STUDIES	12
INTENDED USERS	12
INTENDED PATIENT POPULATION	12
CONTRAINDICATIONS	12
CLINICAL PERFORMANCE CLAIMS	12
CLINICAL BENEFITS	12
CHARACTERIZATION OF USE ENVIRONMENT	12
PRECAUTIONS REGARDING SPECIFIC TYPES OF PATIENTS	13
PREDETERMINED CHANGE CONTROL PLAN	13
PROBE SPECIFICATIONS	16
CHAPTER 2 - SAFETY	17
QUALIFIED MEDICAL PROFESSIONAL	17
MAGNETIC RESONANCE	17
PRODUCT SAFETY	18
ULTRASOUND PROBE AND PRODUCT COMPATIBILITY	18
PATIENT INFORMATION	18
VALIDATE EXAMINATION DATA	18
USER INTERFACE INSTRUCTIONS	18
EXAMINATION VALIDATION	19
FORMAT AND VALUE RANGE	19
MOBILE DEVICE STORAGE	19
MOBILE DEVICE COMPATIBILITY AND REQUIREMENTS	19
JAILBROKEN OR ROOTED MOBILE DEVICE	19
ULTRASOUND-SYSTEM HAZARDS	19
ACOUSTIC OUTPUT AND ALARA	20
NON-ESSENTIAL APPLICATIONS	20
PERMANENT DELETION OF AN EXAM	20
IMAGE QUALITY AND DIAGNOSIS	20
PRESCRIPTIVE GUIDANCE CUES	21

HEARTFOCUS AI ACCURACY, USE, AND IMAGE SAVING	21
SPECIFIC TYPES OF PATIENTS	21
MAINTAIN PROBE CONTACT DURING AUTO RECORD	21
SECURE YOUR MOBILE DEVICE	22
MOBILE DEVICE MANAGEMENT	22
DISABLING TLS	22
CYBERSECURITY PRECAUTIONS AND PRACTICES	22
PHI PROTECTION	23
DICOM SERVER CONFIGURATION	23
HEARTFOCUS LICENSE	23
INTERNET CONNECTION REQUIREMENT	23
USAGE RESTRICTION	24
PROBE FIRMWARE UPDATE REQUIREMENT	24
Rx ONLY	24
CHAPTER 3 - CLINICAL STUDY AND NON-CLINICAL TESTING	25
CLINICAL STUDY	25
STUDY DESIGN	25
RESULTS	26
HUMAN FACTORS VALIDATION	29
SOFTWARE VERIFICATION AND VALIDATION	30
ALGORITHMS PERFORMANCE TESTING	30
DIAGNOSTIC-QUALITY VIEW DETECTION	32
LIVE GUIDANCE	32
AUTO RECORD AND BEST-EFFORT RECORD	32
CHAPTER 4 - SYSTEM DESCRIPTION	34
INTRODUCTION	34
ABOUT THE SOFTWARE	35
SOFTWARE FEATURES	36
SOFTWARE BILLS OF MATERIALS (SBOM)	37
DICOM CONFORMANCE STATEMENT	37
SYSTEM REQUIREMENTS	37
MOBILE DEVICE REQUIREMENTS	37
MOBILE DEVICE SETTINGS	38
MOBILE DEVICE SECURITY	39
IT NETWORK	40
COMPATIBLE ULTRASOUND PROBES	41
ULTRASOUND SYSTEM REQUIREMENTS	41
CHAPTER 5 - THE HEARTFOCUS APPLICATION	42
INSTALLING THE APP	42

LICENSE MANAGEMENT AND PROBE CONNECTION	43
MANAGING EXAMS	43
SETTINGS CONFIGURATION	47
EXAM CREATION	52
CARDIAC ULTRASOUND IMAGE ACQUISITION	56
EXAM VALIDATION	67
EXAM REVIEW	69
UNINSTALLING THE APP	71
CHAPTER 6 - CYBERSECURITY	72
SECURITY ISSUES	72
USER'S CYBERSECURITY RESPONSABILITIES	72
AUDIT LOGS	72
CHAPTER 7 - TROUBLESHOOTING	75
PROBE TROUBLESHOOTING	75
LICENSE TROUBLESHOOTING	75
LIVE GUIDANCE DOESN'T SHOW	76
EXAM CAN'T BE SENT	77

LIST OF FIGURES

Figure 1 - HeartFocus guides operators in the acquisition of diagnostic-quality cardiac clips.	11
Figure 2 - The HeartFocus acquisition page interface	33
Figure 3 - Acoustic windows and their associated views	34
Figure 4 - HeartFocus stakeholder interaction diagram	34
Figures 5a and 5b - HeartFocus Home page listing all the exams acquired on the device	43
Figure 6 - Actions possible depending on the exam status	43
Figure 7 - Confirmation pop-up for deletion	44
Figure 8 - Exam list order management	45
Figure 9 - Exams list filtering example	45
Figure 10 - Storage almost full pop-up	46
Figure 11 - Labeling information page	47
Figure 12 - Setup DICOM Server Page	49
Figure 13 - New DICOM Server configuration	50
Figure 14 - DICOM Servers list	50
Figure 15 & 16 - Success and error message after DICOM server test	50
Figure 17 - New exam page	52
Figure 18 - Warning message when leaving	53
Figure 19 - Missing last name field error message	54
Figure 20 - Wrong format error message	55
Figure 21 - Plug your probe message	56
Figure 22 - Overview of the acquisition page	57
Figure 23 - Slide up panel example	58
Figure 24- Settings subsection	58
Figure 25 - Visual representation of the objective	59
Figure 26 - Navigation bar with different types of records	61
Figure 27 - HeartFocus identifies a diagnostic quality view and automatically records it	62
Figure 28 - HeartFocus has recorded the highest quality clip obtained and allows you to save it	63
Figure 29 - Clip validation after a BER	64
Figure 30 - Slide your finger upper and lower to change the depth	65
Figure 31 - Slide your finger left and right to change the gain	65
Figure 32- Battery icon evolution	66
Figure 33- Temperature icon evolution	66
Figure 34 - Exam validation and review clips pages	67
Figure 35 - Exam information edition page	67
Figure 36 - Exam review page	68

Figure 37 - Error message on exam sent	69
Figure 38 - Success message on exam sent	69
Figure 39 - Exam already sent pop-up	70
Figure 40 - Audit logs showing key actions on Exam, Clip and DICOM server configurations	72

LIST OF TABLES

Table 1- Rationale and testing for each modification	14
Table 2- Ultrasound system requirements	14
Table 3- Primary objectives, endpoints, and success criteria for M1+M2 modifications	15
Table 4- Primary endpoint results	26
Table 5- Secondary endpoint results	27
Table 6- Study results: diagnostic-quality clips	28
Table 7- Primary objectives, endpoints, and success criteria	31

CHAPTER 1 - INTRODUCTION

ABOUT THIS MANUAL

To obtain a printed copy of this manual, at no extra cost, contact HeartFocus support at support@deski.ai.

HeartFocus Software interfaces with the following probes: Butterfly iQ+ and Butterfly iQ3. It is not designed to be compatible with any other ultrasound systems.

This manual accompanies HeartFocus and provides information on configuring HeartFocus and using it to capture diagnostic-quality ultrasound images. This manual is intended to be used by medical professionals who have received appropriate training on ultrasound basics and training on using the HeartFocus software, provided by either DESKi or by a trained clinician using HeartFocus training materials. Additionally, the medical professional should have prior training or experience with the compatible mobile device, including familiarity with navigating the system and switching between applications.



To obtain information about training, you can contact our support team via email at support@deski.ai.

The user can request the electronic or paper form user manual via email at support@deski.ai. This request does not require any extra cost and the maximum delivery time will be 7 calendar days.

Please read this operator's manual in its entirety before using the HeartFocus software.

CONVENTIONS USED IN THIS MANUAL

This manual uses the following symbols and text to indicate specific types of information:

	Indicates supplemental information and provides a tip on how best to use it
	Indicates a potential hazardous situation that, if not avoided, could result in death or serious injury.
	Indicates a potential hazardous situation, that, if not avoided, may result in minor or moderate injury.

ABBREVIATIONS AND ACRONYMS USED IN THIS MANUAL

AI - Artificial intelligence

ALARA - As Low As Reasonably Achievable

AV - Aortic Valve

A2C - Apical 2-Chamber

A3C - Apical 3-Chamber

A4C - Apical 4-Chamber

A5C - Apical 5-Chamber

BER - Best-Effort-Record

BMI - Body Mass Index

DICOM - Digital Imaging and Communications in Medicine

IT - Information technology

IVC - Inferior Vena Cava

LA - Left Atrial

LV - Left Ventricular

MDM - Mobile Device Management

MI - Mechanical Indice

MV - Mitral Valve

PACS - Picture Archiving and Communication System

PCCP - Predetermined Change Control Plan

PHI - Protected Health Information

PLAX - Parasternal Long-Axis

PPV - Positive Predictive Value

PSAX-AV - Parasternal Short-Axis at the Aortic Valve

PSAX-MV - Parasternal Short-Axis at the Mitral Valve

PSAX-PM - Parasternal Short-Axis at the Papillary Muscles

RA - Right Atrial

RNs - Registered Nurses

RV - Right Ventricular

SBOM - Software Bill of Materials

SC-4C - Subcostal 4-Chamber

SC-IVC - Subcostal Inferior Vena Cava

TI - Temperature Indice

TLS - Transport Layer Security

TV - Tricuspid Valve

2D-TTE - Two-dimensional transthoracic echocardiography

UDI - Unique Device Identification

COMPLIANCE

The Ultrasound Systems compatible with HeartFocus software (app) comply with relevant international and national standards and laws. The equipment manufacturer will supply compliance information upon request.

GENERAL DESCRIPTION

OPERATING PRINCIPLE

The HeartFocus software is a radiological computer-assisted acquisition guidance system that provides real-time user guidance during echocardiography to assist the user in acquiring anatomically standard diagnostic-quality 2D echocardiographic views.

It supports the acquisitions of 10 echocardiographic views: Parasternal Long-Axis (PLAX), Parasternal Short-Axis at the Aortic Valve (PSAX-AV), Parasternal Short-Axis at the Mitral Valve (PSAX-MV), Parasternal Short-Axis at the Papillary Muscles (PSAX-PM), Apical 4-Chamber (A4C), Apical 5-Chamber (A5C), Apical 2-Chamber (A2C), Apical 3-Chamber (A3C), Subcostal 4-Chamber (SC-4C), and Subcostal Inferior Vena Cava (SC-IVC).

To allow the acquisition of these views, HeartFocus can connect to an ultrasound system allowing it to receive a stream of ultrasound images.

The standard views acquired with HeartFocus may be assessed by qualified medical professionals to support their decision-making regarding patient care. The collected exams can be transferred notably using DICOM protocols.

HeartFocus assistance operates entirely offline, without requiring a cloud server to provide its core functionalities. All collected medical data is stored locally on the user's personal user's device. This data is never transferred to a server controlled by DESKi.

HeartFocus uses artificial intelligence to emulate the expertise of sonographers in positioning the probe on the patient's chest, and in identifying and recording diagnostic-quality clips.

It proposes 4 major functionalities to assist healthcare professionals in the acquisition of cardiac ultrasound images: Live Guidance, Diagnostic-Quality View Detection, Auto-Record, and Best-Effort-Record. Details about these features can be found in [CHAPTER 5 - THE HEARTFOCUS APPLICATION](#).

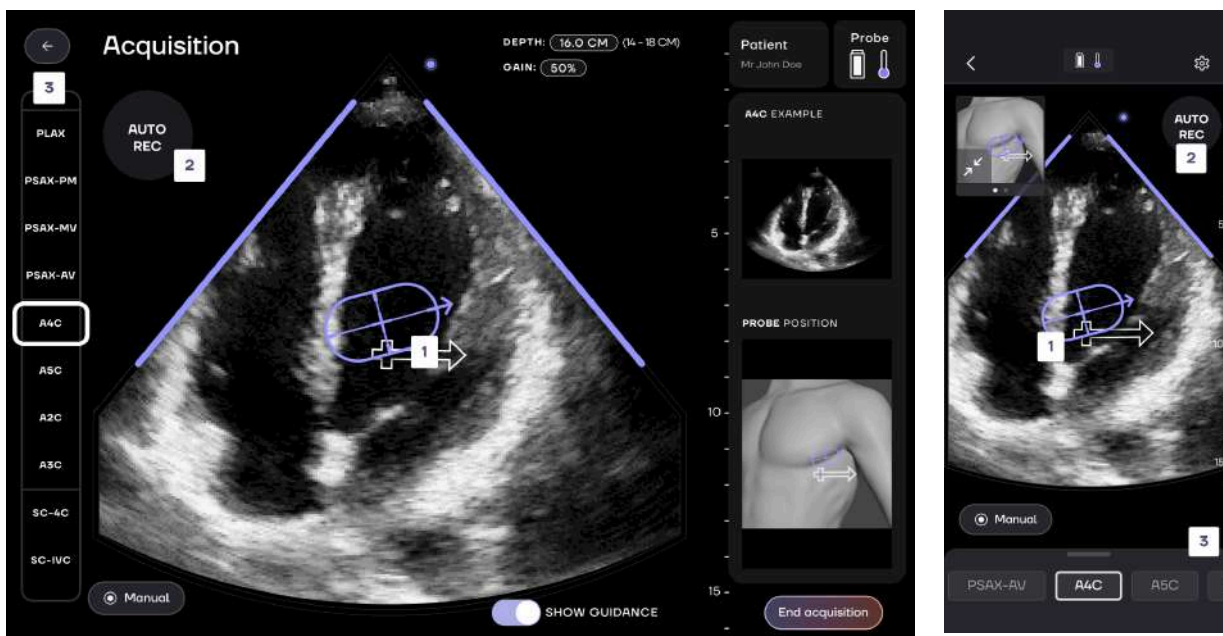

Legend :

- 1. Live Guidance UI
- 2. Auto-Record indicator
- 3. 10 echocardiographic views

Figure 1 - HeartFocus guides operators in the acquisition of diagnostic-quality cardiac clips.

INTENDED USE/INDICATIONS FOR USE

The HeartFocus software is intended to assist medical professionals in the acquisition of cardiac ultrasound images. HeartFocus software is an accessory to compatible general-purpose diagnostic ultrasound systems. HeartFocus guides the acquisition of two-dimensional transthoracic echocardiography (2D-TTE). Specifically, in the acquisition of the following standard views: Parasternal Long-Axis (PLAX), Parasternal Short-Axis at the Aortic Valve (PSAX-AV), Parasternal Short-Axis at the Mitral Valve (PSAX-MV), Parasternal Short-Axis at the Papillary Muscles (PSAX-PM), Apical 4-Chamber (A4C), Apical 5-Chamber (A5C), Apical 2-Chamber (A2C), Apical 3-Chamber (A3C), Subcostal 4-Chamber (SC-4C), and Subcostal Inferior Vena Cava (SC-IVC).

HeartFocus software is indicated for use in adult patients who require a cardiac ultrasound exam.

OTHER TYPES OF STUDIES

The HeartFocus software is not intended for transesophageal echocardiography or any other type of ultrasound study not listed under “Intended Use/Indications for use”.

INTENDED USERS

HeartFocus is intended to be used by medical professionals who have received appropriate training on ultrasound basics and training on using the HeartFocus software, provided by either DESKi or by a trained medical professional while using approved training materials.

Additionally, the medical professional should have prior training or experience with iPadOS or iOS devices, including familiarity with navigating the system and switching between applications.

INTENDED PATIENT POPULATION

The product is intended for adult patients.

CONTRAINDICATIONS

There are no contraindications for using HeartFocus software.

CLINICAL PERFORMANCE CLAIMS

The Clinical performance claims for the HeartFocus software are the following:

- Medical professionals can perform, with a short training, an exam allowing the evaluation of the left ventricular size and function, right ventricular size and presence of non-trivial pericardial effusion,
- Medical professionals can perform, with a short training, an exam allowing the evaluation of the function of the right ventricle, left and right atrium size, segmental kinetics of the left ventricle, aortic/ mitral and tricuspid valves, size of inferior vena cava,
- When used by medical professionals, the auto record feature presents a high specificity of diagnostic quality clips.

CLINICAL BENEFITS

HeartFocus provides a means for any medical professional to perform a cardiac ultrasound for diagnosis and eventually treatment after a short training.

CHARACTERIZATION OF USE ENVIRONMENT

HeartFocus is a software that is intended to be used in daily practice at the point of care, where the ultrasound system compatible with HeartFocus may be used this includes:

- medical offices,

- medical facilities such as hospitals, rehabilitation, recuperative care facilities, and retirement homes,
- patient homes, in the setting of homecare.

Users may refer to compatible ultrasound systems' instructions for use for additional information on their environment of use.

Finally, an internet connection is required to share the collected acquisitions with a data storage system, such as a Picture Archiving System and Communication System (PACS).

PRECAUTIONS REGARDING SPECIFIC TYPES OF PATIENTS

HeartFocus is not recommended for use and may lead to inaccurate guidance and quality indications in patients with the following conditions:

- Patient with cardiac anatomy that does not allow reference electrocardiographic sections to be made (situs inversus, single ventricle, congenital anomalies, etc.),
- Patient having known chest deformity (e.g. pectum excavatum),
- Patient who has undergone total or partial pneumonectomy.

PREDETERMINED CHANGE CONTROL PLAN

HeartFocus could expand its compatibility to additional ultrasound systems and additional operating systems. This will be addressed through 3 modifications in the Predetermined Change Control Plan (PCCP).

- **M1 - Retraining of the core algorithms:** This modification's scope is the retraining of the AI/ML models in the perspective of validating a new manufacturer prior to an M2. The modification is limited to retraining with additional data without changing the models' architecture or training procedure. It notably describes the data collection to retrain the models and the evaluation plan to validate the performance of the retrained models on the already-cleared ultrasound systems.
- **M2 - Extend the use of the ML-DSF with new ultrasound systems:** This modification's scope is the validation of HeartFocus on new ultrasound systems. It notably describes the data collection and evaluation plan to validate the performance of the AI/ML models on the new ultrasound system.
- **M3 - Extend the use of the ML-DSF with new operating systems:** This modification's scope is the extension of the compatibility with new operating systems.

M1 and M2 will be both triggered when DESKi makes a partnership with a new ultrasound manufacturer, and will always be performed together.

Table 1 describes, for each modification, its rationale and how it will be tested to ensure the safety and effectiveness of the device after the modification.

Modification	Rationale	Testing
M1 - Retraining of the core algorithms	Enhance the performance of the AI models in the perspective of extending the use of the ML-DS with new ultrasound systems	Execute AI performance on reference test set and system-level validation tests
M2 - Extend the use of the ML-DSF with new ultrasound systems	Enable support for a broader range of ultrasound systems	Execute AI performance tests on new system test set and system-level validation test
M3 - Extend the use of the ML-DSF with new operating systems	Enable support for a broader range of devices	Execute system-level validation test

Table 1- Rationale and testing for each modification

Table 2 describes the requirements for the ultrasound systems that can be cleared through the PCCP (M1+M2).

Requirement	Description
FDA-cleared ultrasound system compatible with HeartFocus' intended use	<ul style="list-style-type: none"> ● Ultrasound system shall be FDA-cleared ● Validated for cardiac use ● Validated for use on adults
Integration features	<ul style="list-style-type: none"> ● Technical integration shall allow HeartFocus to access live ultrasound stream ● Compatible for an integration on HeartFocus' operating systems
Minimal specifications	<ul style="list-style-type: none"> ● The ultrasound system shall provide an image stream at a minimum of 15 frames per second. ● Center or nominal frequency within 2–5 MHz, suitable for adult transthoracic echocardiography ● At least 30 cm depth, to allow full visualization of adult cardiac structures ● 2D B-mode imaging (grayscale)

	<ul style="list-style-type: none"> • Cone-shaped field of view with an opening angle of at least 80 degrees
--	--

Table 2- Ultrasound system requirements

For each M1+M2, additional testing data will be collected on the new ultrasound system to validate it. 40 US patients and 40 non-US patients will be included, ensuring that at least 25% of patients have a BMI \geq 30 kg/m².

The performance of the retrained algorithms will be validated on: the reference test set (used in the initial 510(k) submission), the test set(s) collected for the validation of ultrasound systems through previous M1+M2 (if applicable), and the new test set collected on the new ultrasound system. Performance testing on all these data should meet the success criteria defined in Table 3. Performance testing will integrate subgroup analysis on the ultrasound probe.

Table 3- Primary objectives, endpoints, and success criteria for M1+M2 modifications

Feature	AI/ML Algorithm	Objective	Endpoint	Success Criteria
Diagnostic-quality view detection	View Classification	Ability to classify ultrasound images with similar accuracy as experts	Cohen's kappa score between the model's predictions and the ground truth labels made by experts (by frame)	Lower bound of the 95% confidence interval of the Cohen's kappa score > 0.6 (substantial agreement) for the 10 reference views
Live guidance	Guidance	Ability to provide successful guidance cues on ultrasound frames	Positive predictive value of successful guidance cues (by frame)	Lower bound of the 95% confidence interval of the positive predictive value > 0.8 for the 10 reference views
Auto record	View Classification + Recording	Ability to save high-quality records according to experts	Positive predictive value of high-quality records among auto-records (by clip)	Lower bound of the 95% confidence interval of the positive predictive value > 0.6 and point estimate of the positive predictive value > 0.8 for the 10

				reference views
--	--	--	--	-----------------

In case M1+M2 fails (success criteria are not met), a single second iteration of M1+M2 will be performed. For the second iteration, the algorithm will be retrained using the existing training dataset and the non-US testing data (40 patients from the new ultrasound system) collected during the first M1+M2 iteration. A new test set of 40 non-US patients and 40 US patients will be collected using the new ultrasound system. The algorithm will then be evaluated using this new test set as well as the reference test set used in the initial 510(k) submission (34 patients from the standalone study and 240 patients from the clinical study, using retrospective analysis) and the test set(s) collected for the validation of previously cleared ultrasound systems (40 US + 40 non-US patients for each previously cleared ultrasound systems). If the second iteration of M1+M2 is not successful, the extension to the new ultrasound system will not be carried out through this PCCP. Each iteration of M1+M2 will be documented.

PROBE SPECIFICATIONS

Please refer to your ultrasound system's user manual for information regarding probe and system specifications. Some of the specifications listed may not be available on your system. General risks related to the ultrasound system, applicable beyond HeartFocus, are delineated in the ultrasound system dedicated user manual. You can directly consult the ultrasound system's user manual for comprehensive information on general ultrasound system-related risks.

CHAPTER 2 - SAFETY

This chapter provides instructions on the safe use of the product and offers information on safety guidelines. Pay close attention to warnings and cautions, and follow them before, during, and after using the product:



WARNING

Indicates a potential hazardous situation that, if not avoided, could result in death or serious injury.



PRECAUTION

Indicates a potential hazardous situation, that, if not avoided, may result in minor or moderate injury.

Use HeartFocus only if you have read and understood all the information in this section. Using the system without proper safety awareness can lead to a loss of time, delaying the opportunity to diagnose or treat the patient as quickly as possible

This section outlines the safety information to consider when using HeartFocus. HeartFocus is intended to be used by medical professionals who have received appropriate training on ultrasound basics and using the HeartFocus software, provided either by DESKi or by a trained medical professional using approved training materials.



PRECAUTION

QUALIFIED MEDICAL PROFESSIONAL

The images and data acquired using the device are to be interpreted only by qualified medical professional



WARNING

MAGNETIC RESONANCE

Keep compatible hardware with HeartFocus, including mobile devices and ultrasound probes, outside the MRI scanner room. For more information about the ultrasound system, please refer to the manuals of the probes you are using with the HeartFocus software.

PRODUCT SAFETY



ULTRASOUND PROBE AND PRODUCT COMPATIBILITY

The HeartFocus software is a software that only operates with compatible ultrasound systems. It is not designed to work with other ultrasound systems. Do not attempt to use HeartFocus with other ultrasound systems. For more details, refer to the [COMPATIBLE ULTRASOUND PROBES](#) section.

Do not use your system in combination with other products or components unless DESKi explicitly recognizes those other products or components as compatible.

Changes and additions to the system should be made only by DESKi or by third parties expressly authorized by DESKi to do so. Such changes and additions must comply with all applicable laws and regulations within the relevant jurisdictions and with best engineering practices.



PATIENT INFORMATION

Verify all patient information before proceeding with the examination. You can modify patient information during the examination validation or review. For more details, refer to the [EXAM VALIDATION](#) section.



VALIDATE EXAMINATION DATA

Before finalizing an examination, ensure that all information is correct and within the expected range. For more details, refer to the [EXAM VALIDATION](#) section.



USER INTERFACE INSTRUCTIONS

The user interface provides prompts to guide the user. Make sure you fully understand the instructions before beginning the examination. For more information on the interface and optimal system usage, refer to the [CARDIAC ULTRASOUND IMAGE ACQUISITION](#) section of the manual.

**PRECAUTION****EXAMINATION VALIDATION**

Before completing an examination, ensure that it is validated correctly. For more information, refer to the [EXAM VALIDATION](#) section of the manual.

**PRECAUTION****FORMAT AND VALUE RANGE**

Ensure that you follow the application's format requirements so that the information is consistent and processed correctly. Some data must be entered in a specific format or within a defined value range. For more details, refer to the [EXAM CREATION](#) section.

**PRECAUTION****MOBILE DEVICE STORAGE**

If you try to start an exam and your mobile device storage is almost full, a warning modal will appear. You will need to first delete some exams before creating new ones.

**PRECAUTION****MOBILE DEVICE COMPATIBILITY AND REQUIREMENTS**

Do not use the HeartFocus App on a mobile device that does not meet the minimum requirements or is not listed as compatible.

The HeartFocus application is designed to function strictly with the mobile devices listed at [List of compatible Apple devices](#). Before using the application, you must verify that your specific device model and operating system are currently supported.

Using the HeartFocus App on a mobile device that does not meet these requirements may affect system performance and image quality

**WARNING****JAILBROKEN OR ROOTED MOBILE DEVICE**

The HeartFocus App should only run on devices that are not jailbroken or rooted to ensure security and data integrity.

**PRECAUTION****ULTRASOUND-SYSTEM HAZARDS**

General risks related to the ultrasound system, applicable beyond HeartFocus, are described in the ultrasound system's dedicated user manual. You should directly consult the

ultrasound system's instructions for use for comprehensive information on general ultrasound system hazards.

 **PRECAUTION**

ACOUSTIC OUTPUT AND ALARA

The compatible ultrasound system with which HeartFocus functions as a software accessory, comply with the Standard for Real-Time Display of Thermal and Mechanical Acoustic Output Indices on Diagnostic Ultrasound Equipment (UD3-2004). It is important to monitor the Mechanical Index (MI) and Temperature Index (TI) values displayed on the Ultrasound System application interface during the exam. When conducting ultrasound studies, follow the ALARA principle: expose the patient to ultrasound energy at a level that is "As Low As Reasonably Achievable". Please refer to the Ultrasound System User Manual for important information on acoustic output and ALARA.

 **PRECAUTION**

NON-ESSENTIAL APPLICATIONS

When using HeartFocus, we recommend disabling non-essential applications to free up resources for the app. Resource-consuming applications such as antivirus software may affect the application's performance.

 **PRECAUTION**

PERMANENT DELETION OF AN EXAM

When deleting an exam, a confirmation message will prompt you to validate the action. Once confirmed, the exam will be permanently deleted and cannot be recovered. For more details, refer to the [MANAGING EXAMS](#) section in the user manual.

 **PRECAUTION**

IMAGE QUALITY AND DIAGNOSIS

Software users are responsible for image quality and diagnosis. The video clips acquired using HeartFocus are to be interpreted only by qualified medical professionals. The qualified medical professional must inspect the data used for analysis and diagnosis and ensure that the data is sufficient and appropriate in anatomical correctness and spatial and temporal resolution for the measurement being employed.

 **PRECAUTION**

PRESCRIPTIVE GUIDANCE CUES

HeartFocus provides Live Guidance that offers suggestions on how to manipulate the probe to capture the desired images. These suggestions have been verified and validated, but individual patient variations may cause the instructions to perform better in some patients than others.

 **PRECAUTION**

HEARTFOCUS AI ACCURACY, USE, AND IMAGE SAVING

HeartFocus provides Live Guidance during cardiac ultrasound exams for 10 standard echocardiographic views.

The accuracy of HeartFocus in estimating image quality has been verified and validated, but individual patient variations may introduce errors. As many echocardiographic views are similar to other views, errors may occur, and the saved HeartFocus video clips may occasionally contain errors. Therefore, it is important to review saved video clips independently using experienced clinical judgment prior to diagnosis.

Making a diagnosis based solely on HeartFocus without applying clinical judgment regarding view correctness and quality is not recommended.

 **PRECAUTION**

SPECIFIC TYPES OF PATIENTS

Ensure that the patient does not have specific conditions such as congenital heart anomalies or thoracic malformations. Refer to the [PRECAUTIONS REGARDING SPECIFIC TYPES OF PATIENTS](#) section for contraindications and recommendations regarding patients not suitable for using HeartFocus.

NOTE

MAINTAIN PROBE CONTACT DURING AUTO RECORD

It is important to maintain the probe contact and position during Auto-Record to ensure the capture of a good clip. If you move the probe, remove it from the patient, or otherwise interrupt the recording, the clip will not be recorded.

**PRECAUTION**

SECURE YOUR MOBILE DEVICE

Information Security: Follow all security and cybersecurity policies of your institution. If you do not know what these policies are, contact your information technology (IT) department. To use the HeartFocus App, it is required that you set a password, passcode, or other security settings to lock the screen of your mobile device. You should also renew periodically the password, passcode, or other security settings to lock the screen of your mobile device.

Usage security: When the use of HeartFocus is no longer necessary, navigate away from the HeartFocus application to disable use and lock the screen if the use of the mobile device is no longer necessary. To ensure maximum security, set up a PIN or passcode for the mobile device, which should typically be renewed every 30 to 90 days. If there is any suspicion of the PIN being compromised, it must be changed immediately, without waiting for the next scheduled renewal.

When HeartFocus is no longer going to be used on the applicable mobile device, please uninstall the application accordingly in order to remove any applicable user and patient data from the mobile device.

**PRECAUTION**

MOBILE DEVICE MANAGEMENT

To avoid data loss when uninstalling HeartFocus by accident, it is recommended that the mobile device is controlled by a Mobile Device Management (MDM) solution.

**PRECAUTION**

DISABLING TLS

It is strongly recommended to enable the TLS protocol on the DICOM server to secure the transmission of patient data. The absence of TLS encryption can lead to interception of communications and a risk of patient data theft by an unauthorized party. Refer to the [IT NETWORK](#) section for detailed information on DICOM server management.

**PRECAUTION**

CYBERSECURITY PRECAUTIONS AND PRACTICES

Malware, computer viruses, ransomware, and other cybersecurity threats are an increasing concern in healthcare IT

systems. Refer to 'Health IT Privacy and Security Resources for Providers' at <https://www.healthit.gov/topic/privacy-security-and-hipaa/> for information and guidance on implementing proper cybersecurity in the healthcare IT environment.



PHI PROTECTION

DICOM studies contain Protected Health Information (PHI). HeartFocus can operate within a PACS network and can send patient studies to a DICOM PACS server. HeartFocus is not intended for long-term storage of studies. This device adheres to HIPAA security and privacy guidelines. When viewing HeartFocus results in your DICOM Viewer, make certain to observe your institution's guidelines and practices for protecting PHI. Please refer to the ultrasound system's User Manual for important information about PHI protection.



DICOM SERVER CONFIGURATION

Ensure that the DICOM server configuration remains unchanged. If any modifications are detected, contact technical support immediately. Any changes to the DICOM server address or configuration must be verified and validated by a system administrator. Incorrect configuration may prevent the transfer of patient exams to the DICOM server, delaying the establishment of the diagnosis and potentially affecting medical care.



HEARTFOCUS LICENSE

A valid license is required to use the HeartFocus app. Please ensure you obtain and activate the license before accessing the app's features. Without a license, access to the app will be restricted. For more details, refer to [LICENSE MANAGEMENT AND PROBE CONNECTION](#).



INTERNET CONNECTION REQUIREMENT

The application requires a periodic internet connection to validate its license and maintain full functionality. Please ensure

your device is connected to the internet regularly to avoid any disruptions in service.



PRECAUTION

USAGE RESTRICTION

The HeartFocus application is designed exclusively for touch-screen interaction. Do not use external input devices such as the Apple Pencil, external keyboards, or computer mice. Using these accessories may interfere with the application's controls and prevent the acquisition of diagnostic-quality data.



PRECAUTION

PROBE FIRMWARE UPDATE REQUIREMENT

The probe's firmware must be kept up to date. Users should refer to the Butterfly probe user manual for detailed information on how to perform the firmware update.



PRECAUTION

Rx ONLY

U.S. federal law stipulates that this device must be sold by a doctor or with a doctor's prescription.

CHAPTER 3 - CLINICAL STUDY AND NON-CLINICAL TESTING

CLINICAL STUDY

A prospective multicentric clinical study was conducted to evaluate the use of HeartFocus by medical professionals without prior echocardiography training.

STUDY DESIGN

Eight (8) registered nurses (RNs) were trained and evaluated on their performance to acquire a 10-view 2D-TTE protocol (two-dimensional transthoracic echocardiography). Participants were scanned by the RN (study exam) and 10 standard views were obtained using a handheld ultrasound system with HeartFocus software: Parasternal Long Axis (PLAX), Parasternal Short Axis at the Aortic Valve (PSAX-AV), Parasternal Short Axis at the Mitral Valve (PSAX-MV), Parasternal Short Axis at the Papillary Muscles (PSAX-PM), Apical-4-Chamber (A4C), Apical-5-Chamber (A5C), Apical-2-Chamber (A2C), Apical-3-Chamber (A3C), Subcostal-4-Chamber (SC-4C), and Subcostal Inferior Vena Cava (SC-IVC). RNs received a half-day training on the basics of cardiac ultrasound and the use of the HeartFocus software and practiced on up to 9 patients before starting the study. The study continued enrollment until the eight RNs had completed scans of 30 patients each. For comparison, participants were also scanned to obtain the same 10 views by a trained medical professional without cardiac guidance, and using the same ultrasound system (control exam).

Following the study and control exams, a panel of five (5) expert cardiologist readers (not the same as the ones scanning the patients) independently provided assessments of whether the patient study, in its totality, provided sufficient information to assess 12 clinical parameters. In addition, this panel of five (5) expert cardiologist readers evaluated if the diagnostic image quality per clip was sufficient for clinical interpretation using the ACEP¹ scale (ACEP ≥ 3); the cardiologists graded each clip. The readers were blinded to assessments from other panel members as well as to which site the images were obtained and whether the images were obtained by an RN or a trained medical professional (sonographer or cardiologist). The results from the expert panel reads were used for the statistical analysis. To reduce possible sources of bias in the design, the RNs, sonographers, and cardiologists were all blinded to results determined by others. Four (4) prospectively defined primary endpoints were evaluated sequentially for the study, all of which assessed whether the patient study exam conducted by the RN, taken as a whole, was of sufficient image quality to visually make these clinical assessments. Specifically, the endpoints assessed whether, in the judgment of expert cardiologists, the studies permitted qualitative visual assessment of left ventricular (LV) size, LV function, right ventricular (RV) size, and the presence of non-trivial pericardial effusion. In addition, expert cardiologist readers performed a qualitative and quantitative assessment of the

¹ Liu, R. B. et al. Emergency Ultrasound Standard Reporting Guidelines. June 2018

ultrasound measurements. They visually determined the presence of LV or RV hypertrophy, dilation of the left or right ventricle or atrium, abnormal LV or RV function, abnormal mitral or tricuspid or aortic valve (*i.e.* structurally normal, abnormal, suspected device), pericardial effusion, dilatation of the IVC or any other abnormality. The cardiologists also measured the LV end-systolic and end-diastolic volumes and function. On parasternal analysis, they measured the septal and posterior wall thickness, the internal diameter of the LV (systole and diastole), as well as the aortic root. The diameter of the IVC was also evaluated. The acquisition time for the limited ultrasound exam for the novices was collected.

RESULTS

A total of 240 adults aged 22 years and older who were scheduled for a clinically indicated echocardiography examination at one of the two investigation centers were included in this study, with 120 patients at Site 1 (France) and 120 patients at Site 2 (USA).

The four primary endpoints were satisfied and demonstrated the clinical utility of HeartFocus guidance for medical professionals without specialized echocardiography training. Specifically, the eight (8) RNs acquired echocardiographic exams of sufficient image quality to make clinical assessments in the proportion of study exams conducted, as shown below.

Table 4- Primary endpoint results

Endpoint	Percent of diagnostic quality % [95% Wilson CI]
Qualitative Visual Assessment of LV Size	100 [98.4;100]
Qualitative Visual Assessment of LV Function	100 [98.4;100]
Qualitative Visual Assessment of RV Size	100 [98.4;100]
Qualitative Visual Assessment of Non-Trivial Pericardial Effusion	100 [98.4;100]

Secondary endpoints and additional analyses presented below were not evaluated based on a specific hypothesis. Since the evaluation of secondary endpoints and additional analyses did not allow for control of Type I error, the study results are presented as a descriptive demonstration of the use of HeartFocus guidance for the specific secondary endpoints and additional analyses.

Additional secondary endpoints were evaluated and demonstrated the robustness of the data, including eight (8) additional patient-level clinical parameters evaluated and each had a high proportion of scans considered to be of sufficient image quality to make each of the eight (8) additional patient-level clinical parameter assessments, *i.e.*, qualitative visual assessment of RV function, inferior vena cava (IVC) size, left atrial (LA), right atrial

(RA) size, aortic valve (AV), mitral valve (MV), tricuspid valve (TV) and segmental kinetics of the LV.

Specifically, the eight (8) RNs acquired echocardiographic exams of sufficient image quality to visually make clinical assessments in the proportion of study exams conducted, as shown below.

Table 5- Secondary endpoint results

Endpoint	Percent of diagnostic quality % [95% Wilson CI]
Qualitative Visual Assessment of RV Function	99.6 [97.7;99.9]
Qualitative Visual Assessment of LA Size	100 [98.4;100]
Qualitative Visual Assessment of RA Size	98.8 [96.4;99.6]
Qualitative Visual Assessment of Segmental Kinetics of the LV	95.4 [92.0;97.4]
Qualitative Visual Assessment of AV	98.8 [96.4;99.6]
Qualitative Visual Assessment of MV	100 [98.4;100]
Qualitative Visual Assessment of TV	95.4 [92.0;97.4]
Qualitative Visual Assessment of IVC Size	78.3 [72.7;83.1]

In addition to assessing if image quality was sufficient to make assessments, cardiologists also made specific qualitative visual assessments based on the study and control exams (e.g., presence or absence of non-trivial pericardial effusion). The proportion of scans in which the diagnostic decision was the same between study and control exams was very high, further demonstrating the usability of HeartFocus guidance. For primary clinical parameters, the range was 87.5% to 98.3%. Similarly, for secondary clinical parameters, the range was 87.1% to 99.6%.

To provide a robust assessment of the performance of HeartFocus guidance, subjects enrolled in the study included a broad range of patient characteristics representative of the intended use population. The standard of care echo revealed a high proportion of cardiac abnormalities (70.4%). In addition, many of the study patients were inpatients or had other challenging characteristics such as high BMI (59.6% with BMI > 25) and cardiac implantable devices (18.8%).

Subgroup analyses were conducted to evaluate the impact of specific baseline and demographic characteristics (i.e., BMI, presence of known cardiac abnormalities, scan sequence number within each acquiring nurse, and study site) on the outcomes of the

primary and secondary endpoints. The results demonstrated consistent performance across subgroups.

Furthermore, it was evaluated whether the RN users were able to obtain a high proportion of clips that were considered diagnostic quality. Specifically, the eight (8) RNs acquired echocardiographic clips of diagnostic-image quality for each of the standard views in the following proportion of study exams conducted.

Table 6- Study results: diagnostic-quality clips²

View	Percent of diagnostic quality % [95% Wilson CI]
PLAX	97.5 [94.7;98.8]
PSAX-AV	89.2 [84.6;92.5]
PSAX-MV	90.8 [86.5;93.9]
PSAX-PM	97.1 [94.4;98.6]
A4C	96.2 [93.0;98.0]
A5C	93.3 [89.4;95.9]
A2C	82.5 [77.2;86.8]
A3C	90.0 [85.6;93.2]
SC-4C	89.2 [84.6;92.5]
SC-IVC	77.5 [71.8;82.3]

The objective was to acquire 10 clips per patient so in total 2400 clips. Novices recorded 2362 clips and missed 38 clips. Among the recorded clips, 67.4% of the clips were saved with the “Auto-Record” feature, 21.3% with the “Best-Effort-Record” feature, and 11.3% with the “Manual Record” feature.

99.7% of the clips recorded with the “Auto-Record” feature were of diagnostic quality, demonstrating the high specificity of this feature. 93.9% of the clips recorded with the “Best-Effort-Record” feature were of diagnostic quality, and 40.5% of the clips recorded with the “Manual Record” feature were of diagnostic quality.

The average acquisition time per limited exam for novices in both centers was 23.6 ±10.6 minutes.

² Mean acquisition time per exam for RNs is 23.6 ± 10.6 minutes.

The study also demonstrated the safety profile of HeartFocus software. No device-related adverse events were reported in the pivotal study. In sum, this pivotal clinical study validated the clinical use of the HeartFocus software by users with no prior scanning experience to acquire limited (10-view) two-dimensional, point-of-care echocardiograms.

NOTE

The device has not been validated on expert sonographers and cardiologists who are qualified ultrasound users to use this aid during acquisition.

HUMAN FACTORS VALIDATION

A first human factors validation study on HeartFocus was conducted following the FDA Guidance Document, “Applying Human Factors and Usability Engineering to Medical Devices” and IEC 62366 1:205 standard. This study aimed to demonstrate that the HeartFocus user interface is safe and effective for the intended users, uses, and use environments. The HeartFocus user interface was developed through a series of preliminary evaluations during its development process to find the best and most effective design. The final version of the device has then been assessed in a summative evaluation.

During this evaluation, the characteristics of the user interface that could affect safety were identified by conducting a task analysis and recorded as use scenarios. 9 use scenarios, representing the primary functions of HeartFocus have been established. Potential errors leading to potential risks in these use scenarios have then been identified. The 7 scenarios concerned were considered “hazard-related” and selected for the usability summative evaluation, but no risk was identified regarding the health and safety of users.

The summative evaluation was conducted with 31 participants representing the intended users of HeartFocus and included novices (registered nurses) and trained medical professionals (cardiologists, sonographers, intensivists, emergency physicians).

User tests were carried out to observe the execution of all hazard-related scenarios. They were performed in an environment representative of the intended use conditions of HeartFocus. The user tests achieved a high success rate, with 100% success in 4 of the 7 scenarios and 97% success in the remaining 3, providing robust evidence that critical tasks can be performed with high accuracy and minimal risk.

Following the initial validation, an additional usability study was conducted for HeartFocus v1.3 to support the extension of the software to mobile phone platforms. This study aimed to demonstrate that the adaptation of the user interface to a smaller screen remains safe and effective. While the core clinical workflows and algorithms remain unchanged, a risk-based assessment identified two critical tasks as being potentially impacted by the new visual scaling and layout repositioning.

The summative evaluation for this update was performed with 8 representative novice users, representing a "worst-case" scenario for interface interpretation. Testing was conducted in a simulated clinical environment using various iPhone models to verify that the reduction in display area did not interfere with the user's ability to perceive guidance cues or interact with recording controls.

The evaluation resulted in a 100% success rate for all tested scenarios, with no use errors or close calls observed. Participants reported high levels of usability through standardized System Usability Scale (SUS) and AttrakDiff assessments. These results provide robust evidence that the HeartFocus user interface remains safe and effective across different device form factors, ensuring that the transition from tablet to phone does not introduce new risks to the image acquisition process.

SOFTWARE VERIFICATION AND VALIDATION

Software Basic documentation level verification and validation testing was conducted as required by IEC 62304 and FDA Guidance on General Principles of Software Validation, January, 2002.

The Quality Management System of DESKi describes how software as a medical device is specified, developed, and released, compliant with the IEC 62304: 2006 standard & A1: 2015.

DESKi has developed a Quality Management System according to the International Standard ISO 13485.

A comprehensive risk analysis was generated with detailed description of the hazards, their causes and severity, as well as acceptable methods for control of the identified hazards. DESKi developed a description, with test protocols including pass/fail criteria and report of results, of acceptable verification and validation activities at the unit, integration, and system level.

ALGORITHMS PERFORMANCE TESTING

Performance testing of the AI/ML algorithms has been conducted to evaluate the effectiveness of the AI/ML features of the HeartFocus software.

In total, the AI/ML algorithms were trained and tuned on 1,658 subjects and more than 1.5 millions ultrasound images, of which approximately 300,000 were collected using Butterfly probes. Performance testing was assessed on 40 French subjects (456,148 ultrasound images), and on 40 American subjects (399 ultrasound clips). Both training/tuning data and test data were collected on subjects of varying body mass index (BMI), age, and sex.

The performance of the retrained AI/ML algorithms was also evaluated using the same test set as the previous version, to ensure continued compatibility with the previously cleared ultrasound system.

The main features of the system were tested independently using the primary endpoints described in Table 7. Secondary endpoints were also evaluated to demonstrate the ability of the algorithms to:

- accurately detect anatomical structures of the heart in ultrasound images to indicate whether they can be used to guide the user,
- maximize the likelihood of capturing high-quality records,
- provide a relevant estimate of recording quality,
- automatically record clips identified to be of diagnostic quality by experts,
- guide from one reference view to another.

Subgroup analyses were performed across varying BMI (< 25, ≥ 25 and < 30, ≥ 30), age (< 65, ≥ 65), and sex (male, female).

Table 7- Primary objectives, endpoints, and success criteria

Feature	AI/ML Algorithm	Objective	Endpoint	Success Criteria
Diagnostic-quality view detection	View Classification	Ability to classify ultrasound images with similar accuracy as experts	Cohen's kappa score between the model's predictions and the ground truth labels made by experts (by frame)	Lower bound of the 95% confidence interval of the Cohen's kappa score > 0.6 (substantial agreement) for the 10 reference views
Live guidance	Guidance	Ability to provide successful guidance cues on ultrasound frames	Positive predictive value of successful guidance cues (by frame)	Lower bound of the 95% confidence interval of the positive predictive value > 0.8 for the 10 reference views
Auto record	View Classification + Recording	Ability to save high-quality records according to experts	Positive predictive value of high-quality records among auto-records (by clip)	Lower bound of the 95% confidence interval of the positive predictive value > 0.6 and point estimate of the positive predictive

				value > 0.8 for the 10 reference views
--	--	--	--	--

DIAGNOSTIC-QUALITY VIEW DETECTION

Experts (cardiologists and/or experienced sonographers) annotated the ultrasound clips to identify diagnostic-quality images. First annotation was performed by an expert (expert annotator) and was reviewed by a second expert (expert reviewer). When necessary, disagreements were resolved either through direct reconciliation by the 2 experts or by a third expert. The ground truth (or gold standard) was defined from the consensus between the first expert annotator and the expert reviewer(s). For each ultrasound frame, the View Classification model predicts whether it is of diagnostic quality. The evaluation consists of comparing the agreement between the model predictions and the experts' annotations using Cohen's kappa score³.

The evaluation was performed on 61,384 images from 40 subjects. Cohen's kappa scores range from 0.640 [0.625, 0.655] to 0.929 [0.924, 0.934], meeting the success criteria of Cohen's kappa score > 0.6 on the lower bound of the 95% CI for each reference view.

LIVE GUIDANCE

Live guidance was evaluated on ultrasound acquisitions where the frame and probe position were collected simultaneously. For a given reference view, each ultrasound frame is at a certain position (called the actual position) regarding the target position (where diagnostic-quality frames are captured). The Guidance model predicts guidance cues to help navigate toward this target position. The evaluation consists of computing the positive predictive value (PPV), which represents the proportion of ultrasound frames where the final position, after following the guidance cues, is closer to the target position than the actual position.

The evaluation was performed on 456,148 images from 40 subjects. Guidance cues PPV ranges from 0.825 [0.820, 0.830] to 0.899 [0.895, 0.903], satisfying the success criteria of PPV > 0.8 on the lower bound of the 95% CI for each reference view.

AUTO RECORD AND BEST-EFFORT RECORD

For each reference view, long-duration clips where an operator moves the ultrasound probe and obtains both diagnostic-quality and non-diagnostic-quality frames were collected. Based on the View Classification model's output, the Recording algorithms aim to automatically record diagnostic-quality clips (short duration) that could be saved in the clinical practice. The positive predictive value (PPV) of the Recording algorithms is evaluated for each reference view.

³ Cohen, J. (1960). A Coefficient of Agreement for Nominal Scales. *Educational and Psychological Measurement*, 20(1), 37-46. <https://doi.org/10.1177/001316446002000104>

The evaluation was performed on 366 long-duration clips from 40 subjects. While using the Auto record feature solely, the PPV ranges from 0.871 [0.711, 0.949] to 1.000 [0.908, 1.000], meeting the success criteria of $PPV > 0.6$ on the lower bound of the 95% CI and $PPV > 0.8$ on the point estimate for each reference view. While using both the Auto record and Best-Effort record, the PPV ranges from 0.872 [0.733, 0.944] to 1.000 [0.910, 1.000].

Overall, these performance testing results provide evidence in support of the functionality of HeartFocus AI/ML algorithms in accordance with the modifications “M1 - Retraining of the core algorithms” and “M2 - Extend the use of the ML-DSF with new ultrasound systems” of our [PREDETERMINED CHANGE CONTROL PLAN](#).

CHAPTER 4 - SYSTEM DESCRIPTION

INTRODUCTION

The HeartFocus software pairs with compatible ultrasound systems to acquire cardiac ultrasound images.

The AI technology assists healthcare professionals, regardless of their level of echocardiography training or knowledge, in the acquisition of cardiac ultrasound images by providing real-time guidance, automatic image recording, and quality assessment.

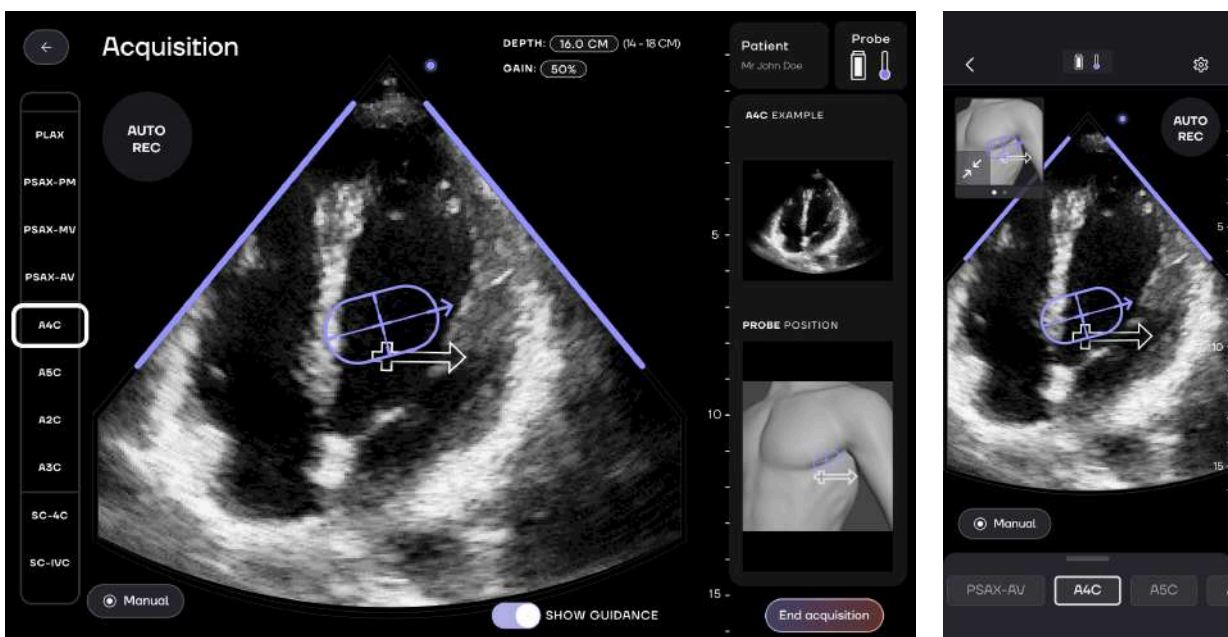

Figure 2 - The HeartFocus acquisition page interface

HeartFocus software is an advanced, AI-powered mobile application designed to assist healthcare professionals in obtaining high-quality echocardiographic images.

Thanks to advanced machine-learning models, HeartFocus provides real-time adaptive guidance to users, improving their ability to correctly position and orientate the ultrasound probe.

This software ensures the acquisition of diagnostic-quality echographic views of the heart, even for users with limited experience. HeartFocus offers guidance for capturing the 10 most commonly used cardiac views through three acoustic windows: parasternal, apical, and subcostal.

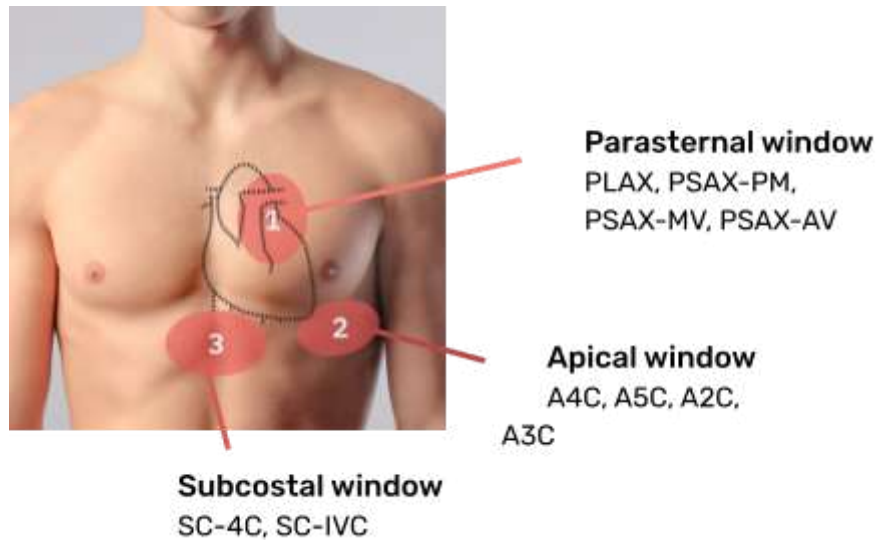

Figure 3 - Acoustic windows and their associated views

ABOUT THE SOFTWARE

HeartFocus software is an application that is installed on a mobile device (iPad or iPhone). It receives a stream of images from the Compatible probe and analyzes them in real-time to provide live cues to the user on how to move the probe on the patient's chest to obtain diagnostic-quality images. It emulates how a sonographer would manipulate the ultrasound probe to acquire and record a diagnostic-quality clip. HeartFocus software also enables the user to send acquired images to PACS servers using the DICOM standard format for the images.

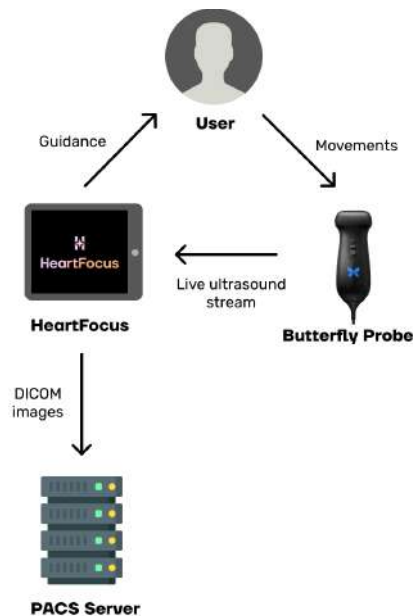

Figure 4 - HeartFocus stakeholder interaction diagram

SOFTWARE FEATURES

The HeartFocus software allows the creation and management of echocardiographic exams. For the performance of an exam, it supports the acquisition of 10 reference views through 3 acoustic windows :

- Through the parasternal window: Parasternal Long-Axis (PLAX), Parasternal Short-Axis at the Aortic Valve (PSAX-AV), Parasternal Short-Axis at the Mitral Valve (PSAX-MV), Parasternal Short-Axis at the Papillary Muscles (PSAX-PM)
- Through the apical window: Apical 4-Chamber (A4C), Apical 5-Chamber (A5C), Apical 2-Chamber (A2C), Apical 3-Chamber (A3C)
- Through the subcostal window: Subcostal 4-Chamber (SC-4C), and Subcostal Inferior Vena Cava (SC-IVC)

HeartFocus offers 4 major functionalities to assist healthcare professionals in the acquisition of cardiac ultrasound images

- **Live Guidance:** This feature provides real-time cues to the user on how to move the probe on the patient's chest to obtain diagnostic-quality images. The guidance UI is generated by a machine learning model that infers the probe's position relative to the target position, i.e. that would provide diagnostic-quality images. It emulates how a sonographer would manipulate the ultrasound probe to acquire a diagnostic-quality clip.
- **Diagnostic-Quality View Detection:** This feature detects real-time diagnostic-quality images and informs the user to hold the position and perform automatic recording. This detection is performed by a machine learning model that also allows the grading of the recorded clips. When the probe is well positioned and the image is of diagnostic quality, a triangle surrounding the ultrasound image appears in color shifting from blue (lower quality) to green (higher quality). The user shall hold the position so that an automated recording can be performed.
- **Auto-Record:** This feature triggers an automatic recording of a clip when the quality is predicted to be of diagnostic quality for a sufficient amount of time. It emulates how a sonographer would identify diagnostic-quality clips and record them.
- **Best-Effort-Record (BER):** This feature continually assesses clip quality while the user is scanning and, if the user cannot obtain a clip sufficient for an Auto-Record, the software allows the user to record the highest quality clip obtained so far retrospectively. It emulates how a sonographer would identify the best diagnostic-quality clips retrospectively.

The standard views acquired with HeartFocus may be assessed by qualified medical professionals to support their decision-making regarding patient care. The collected exams can be transferred notably using DICOM protocols.

SOFTWARE BILLS OF MATERIALS (SBOM)

To ensure transparency and security, you can obtain the Software Bill of Materials (SBOM) for our medical device software. The SBOM provides detailed information about the components and dependencies used in our software.

A machine-readable (CDX) version of the Software Bill of Materials (SBOM) can be obtained by contacting our support team via email at support@deski.ai.

DICOM CONFORMANCE STATEMENT

HeartFocus allows you to transfer exams to PACS servers using DICOM protocols. If needed, the DICOM conformance statement of HeartFocus can be obtained by contacting our support team via email at support@deski.ai.

SYSTEM REQUIREMENTS

MOBILE DEVICE REQUIREMENTS

The HeartFocus App is designed to operate on specific mobile devices that meet performance and safety standards. Because mobile device manufacturers frequently update hardware and software, the list of compatible devices is subject to change.

For the most up-to-date list of compatible devices and operating systems, please strictly refer to the official compatibility list at: [List of compatible Apple devices](#)

The software requires a display size equivalent to or larger than 8.3 inches and a minimum display aspect ratio of 1.523:1 to ensure proper visualization of the interface and diagnostic data.

NOTE

LOW DISPLAY RATIO DEVICES

Devices with a lower ratio or display size than the one on which HeartFocus has been tested do not guarantee a display that allows proper use of the software.

iPad Minimum Requirement

Operating System	iPad 6th Gen/iPadOS 17 or newer. Not compatible with beta or unreleased versions.
CPU	Apple A10 Fusion
GPU	A10-integrated PowerVR GPU (~6-core)

RAM	2 GB LPDDR4 SDRAM
Storage	32 GB
Display Size	Equivalent to or larger than 8.3 inches
Display ratio	Minimum display aspect ratio of 1.523:1

iPhone Minimum Requirement

Operating System	iPhone XS/iOS 17 or newer. Not compatible with beta or unreleased versions.
CPU	Apple A12 Bionic
GPU	Apple G11P 4-core GPU
RAM	3 GB
Storage	64 GB
Display Size	Equivalent to or larger than 4.7 inches
Display Ratio	Minimum display aspect ratio of 16:9

MOBILE DEVICE SETTINGS

The screen zoom of the mobile device must be set to their default level.

The mobile device should be configured with the screen auto-lock set to the minimum duration allowed by the operating system.

The brightness of the mobile device should be configured to automatic adjustment or to the maximum level.

A passcode or password must be required on the mobile device.

To ensure optimal performance of HeartFocus during ultrasound exam acquisition, users are advised to close all non-essential applications running on the device before starting HeartFocus.



AVOID RUNNING RESOURCE-INTENSIVE APPLICATIONS CONCURRENTLY WITH HEARTFOCUS

To ensure reliable and accurate operation of HeartFocus during ultrasound exam acquisition, users must avoid running

resource-intensive applications, such as antivirus software or system scans, concurrently with HeartFocus. Such applications may impact the device's performance and compromise the quality of the ultrasound acquisition.

MOBILE DEVICE SECURITY

HeartFocus stores and displays patient data, here are recommendations to reduce risk of unauthorized access to the patient data.

Follow all security and cybersecurity policies of your institution. If you do not know what these policies are, contact your information technology (IT) department.

To reduce the risk of unauthorized access to HeartFocus:

- The mobile device should be configured so that:
 - It automatically locks the screen after the minimum duration allowed by the operating system.
 - It requires a PIN or passcode to be unlocked.
- When the use of HeartFocus is no longer necessary:
 - Navigate away from the HeartFocus application to disable use and lock the screen.

To ensure maximum security of the PIN or passcode of the mobile device:

- Renew the PIN or passcode for the mobile device every 30 to 90 days.
- If there is any suspicion of the PIN being compromised, it must be changed immediately, without waiting for the next scheduled renewal.
 - HeartFocus provides audit logs that may indicate if patient data have been accessed or modified. See section Audit Logs.

To remove data stored by HeartFocus from your mobile device, uninstall the HeartFocus application using the standard iPadOS or iOS process when you no longer intend to use it.

NOTE

APP UNINSTALLATION

If you uninstall the HeartFocus application from your mobile device, all stored data will be permanently deleted and cannot be recovered. Make sure to transfer any important information before uninstalling.

IT NETWORK

HeartFocus Software (app) needs a data connection provided by the mobile device when the user wants to send exams to a DICOM enabled PACS.

The IT organization is responsible for configuring HeartFocus with the DICOM server parameters as specified in the section *Setting up a DICOM Server*.

As indicated in the section *Setting up a DICOM Server*, the Transport Security Layer (TLS) should be enabled to ensure a secured transfer of exams to a DICOM server.

The connection with DICOM server should enable a transfer with a transfer speed of 25 Mbps to ensure a transfer of an exam in about 1 minute. A higher bandwidth will shorten this delay.

If the DICOM server is configured with a disabled TLS parameter, your organization should ensure that the network used by the mobile device is safe to transfer data over a non-encrypted link. Consult with your IT/Security department to ensure that security and patient data protection is in accordance with the policy of your institution.

PRECAUTION

DISABLING TLS

It is strongly recommended to enable the TLS protocol on the DICOM server to secure the transmission of patient data. The absence of TLS encryption can lead to interception of communications and a risk of patient data theft by an unauthorized party.

If the DICOM server address or configuration is changed, HeartFocus notifies the user that the exam cannot be sent. In that case, one needs to set the correct parameters as explained in the section *Setting up a DICOM Server*.

PRECAUTION

DICOM SERVER CONFIGURATION

Any change to the DICOM server address or configuration must be verified and validated by a system administrator. Incorrect configuration may prevent the transfer of patient exams to the DICOM server, delaying the establishment of the diagnosis and potentially affecting medical care.

NOTE

DESKi EXAM DATA ACCESS

HeartFocus assistance operates entirely offline, without requiring a cloud server to provide its core functionalities.. All collected medical data is stored locally on the mobile device. This data is never transferred to a server controlled by DESKi.

COMPATIBLE ULTRASOUND PROBES

HeartFocus Software (app) operates only the following probes:

- Butterfly iQ+
- Butterfly iQ3

ULTRASOUND SYSTEM REQUIREMENTS

If you are using your Butterfly probe for the first time, you must register it in the Butterfly app before you can use the HeartFocus app.

Every 24 hours of cumulative use of the ultrasound system, it is necessary to open the Butterfly app to perform a “sanity check.” A pop-up message will appear on the screen, inviting you to do so.

For further information, please refer to [Butterfly user manuals](#).

CHAPTER 5 - THE HEARTFOCUS APPLICATION

INSTALLING THE APP

NOTE

INTERNET CONNECTION REQUIRED

An Internet connection is required to download, install, or update the HeartFocus application. No Internet connection or wireless connectivity is required to use the HeartFocus when performing an exam acquisition. In order to ensure the last version of HeartFocus is installed on the mobile device, the mobile device should have access to the internet once every 30 days.

NOTE

OBLIGATIONS

Before using HeartFocus, remember to declare “I declare that I read and understood the IFU and I am aware of the required training”

1. On your device, ensure you are connected to the Internet

In the device settings, ensure the WiFi is enabled and a connection has been established to a secure network.

2. Download the HeartFocus App

Search for the HeartFocus App in the App Store on your device. Start the download and wait until it is complete. The HeartFocus App icon will appear on the home screen of your device.

If you are using your Butterfly ultrasound system for the first time, you must set it up with the Butterfly app before you can use the HeartFocus app. Otherwise, an error message will appear on the screen, preventing you from accessing image acquisition (see [TROUBLESHOOTING](#)). For more information, refer to your ultrasound device’s user manual.

3. Preliminary Preparations

- Verify that the device is charged as needed to complete the exam.
- Have the ultrasound gel ready for use.
- Adjust the environment.

LICENSE MANAGEMENT AND PROBE CONNECTION

You may only use HeartFocus with probes that are linked to a valid license. License linking is performed on the [HeartFocus Portal](#), where you may purchase licenses and link licenses to your compatible probes using their serial number.

Upon app launch and probe connection, the software communicates securely with the HeartFocus Portal to verify the activation status of the connected probe.

If the probe has a valid license that the software can verify, you'll be able to use HeartFocus. Otherwise you may troubleshoot your probe connection on the acquisition page following the indicated instructions. If you are not able to troubleshoot your connection, see our [TROUBLESHOOTING](#) section or contact support@deski.ai.

MANAGING EXAMS

- **List of the exams**

You can access the list of the exams acquired on HeartFocus with your device on the home page of the application. The application presents a row or card for each exam performed, displaying the following information:

- First name and last name of the patient
- Date and hour of the exam creation
- Status of the exam: "In progress" or "Done"
- The synchronization status of the exam
 - Nothing is displayed if the exam is not in "Done" status
 - "Not sent" is displayed if the exam has never been sent to a DICOM server
 - "Sent" if the exam has been sent to a DICOM server
 - Note that the mention "Changes made" is also displayed if the exam has been modified after being sent

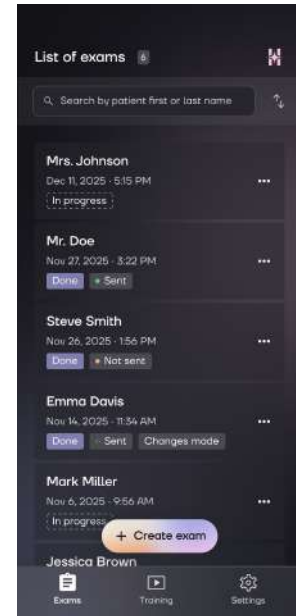
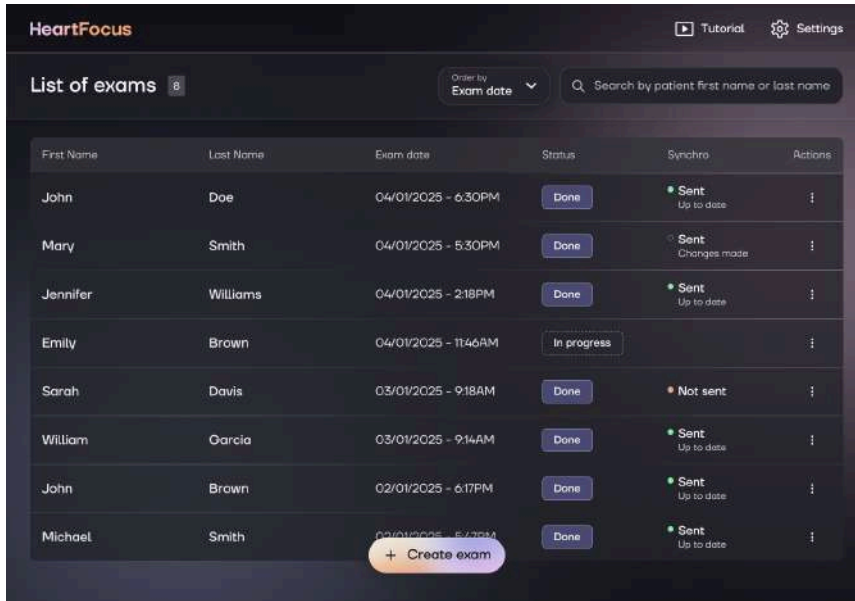

Figures 5a and 5b - HeartFocus Home page listing all the exams acquired on the device

● Actions

On each row, two actions are possible, accessible with the 3-dots icon. The actions possible depend on the status of the exam:

- Continue the acquisition if the exam is still in progress or open the exam if it is done (see [EXAM REVIEW](#)). This action is also the default action when a table row is directly tapped.
- Delete the exam

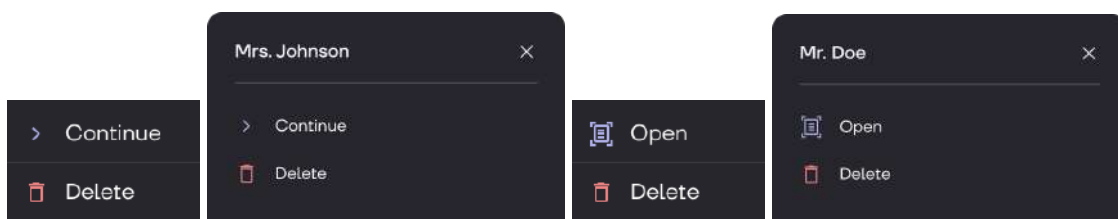

Figure 6 - Actions possible depending on the exam status

If you want to delete an exam, you will be asked for confirmation to avoid any errors.



EXAM DELETION IS IRREVERSIBLE

Once deleted, the exam cannot be restored.

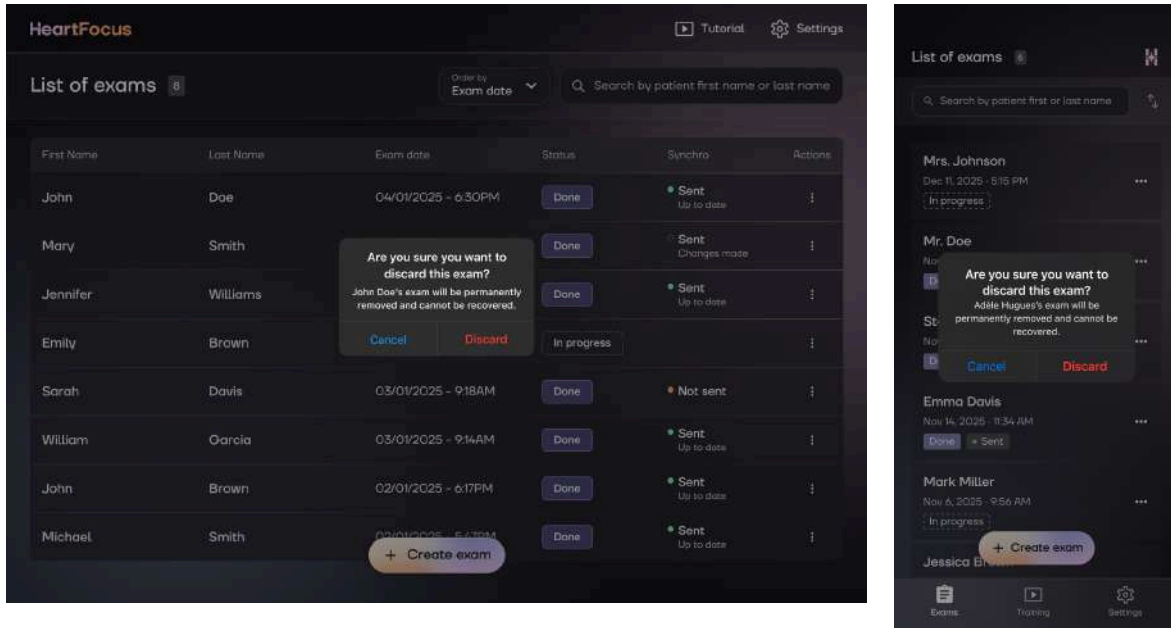

Figure 7 - Confirmation pop-up for deletion

NOTE

USAGE SECURITY

When the exams generated by using the HeartFocus application and stored locally on the device are no longer needed for clinical purposes, it is strongly recommended to delete them to reduce risks, especially if the exam has been successfully transferred to the DICOM server.

NOTE

NOT MORE THAN 100 EXAMS RECOMMENDATION

To ensure a smooth user experience, there should not be more than 100 exams listed in the HeartFocus application, it is strongly recommended to delete them to reduce risks.

● **Order the exams**

You can order the exam list by :

- Exam creation date (the most recent exams will appear first)
- Patient first name (the first names starting with A will appear first)
- Patient last name (the last names starting with A will appear first)
- Status (the exams “In Progress” will appear first)

You can change the order in which exams are displayed by pressing the dropdown menu or the two-arrows icon on top of the screen.

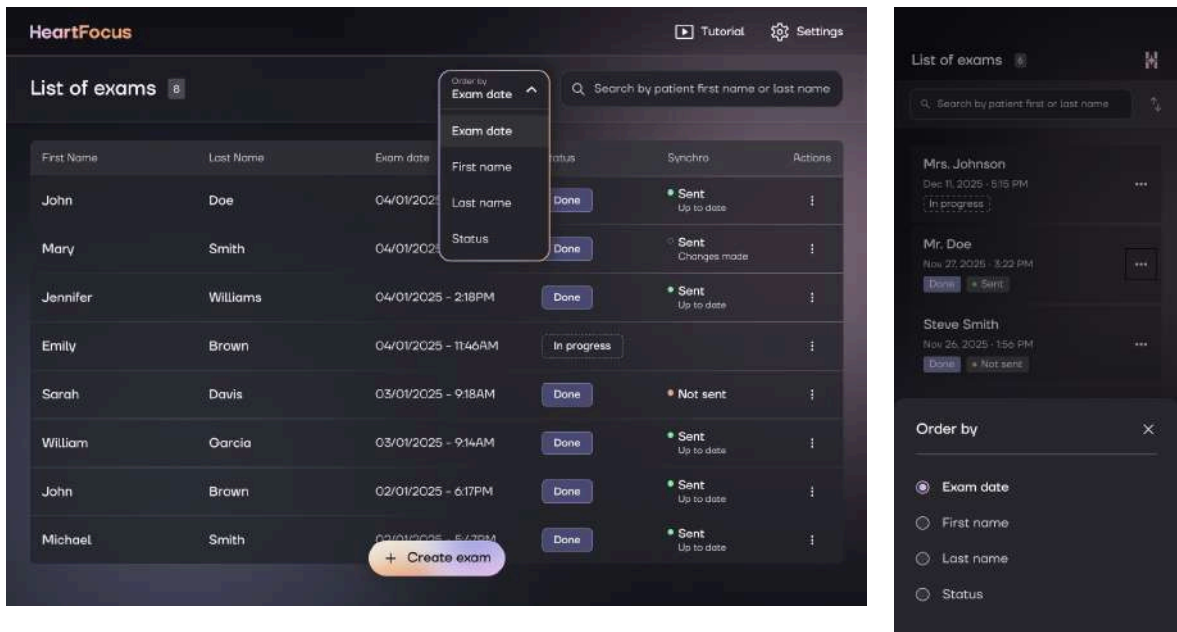

Figure 8 - Exam list order management

- Filter the exams

You can search for a specific exam by typing the patient’s first or last name in the search bar. The list will then be filtered to show only the exams that meet your constraints.

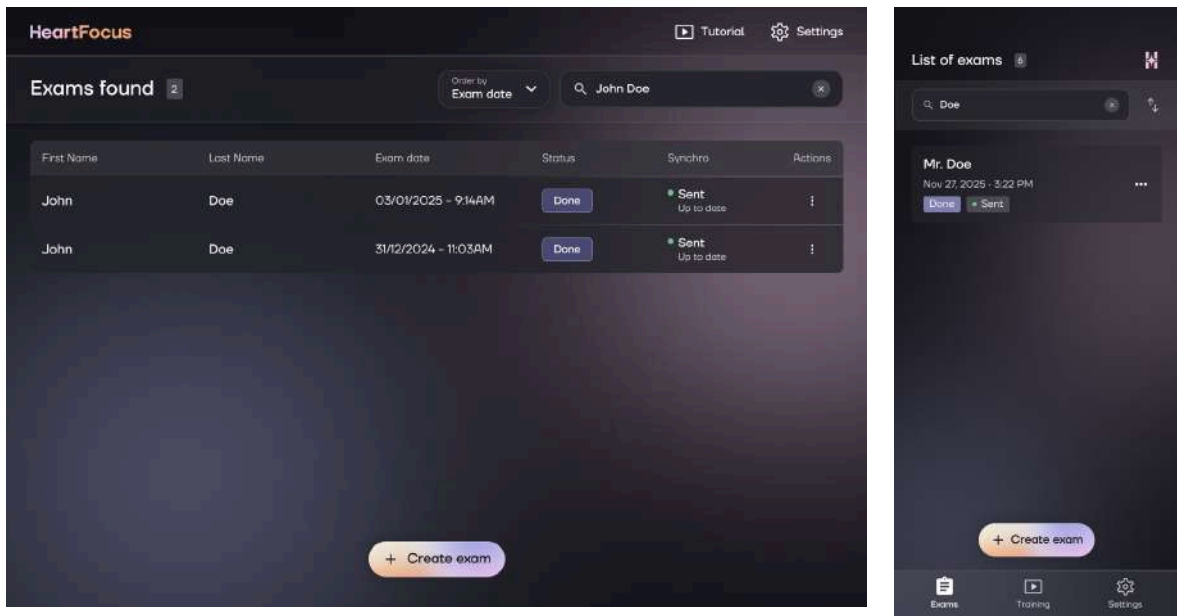

Figure 9 - Exams list filtering example

- **Mobile device storage is full**

If you try to create an exam and your device storage is almost full, a warning modal will appear. You will need to first delete some exams before creating new ones.

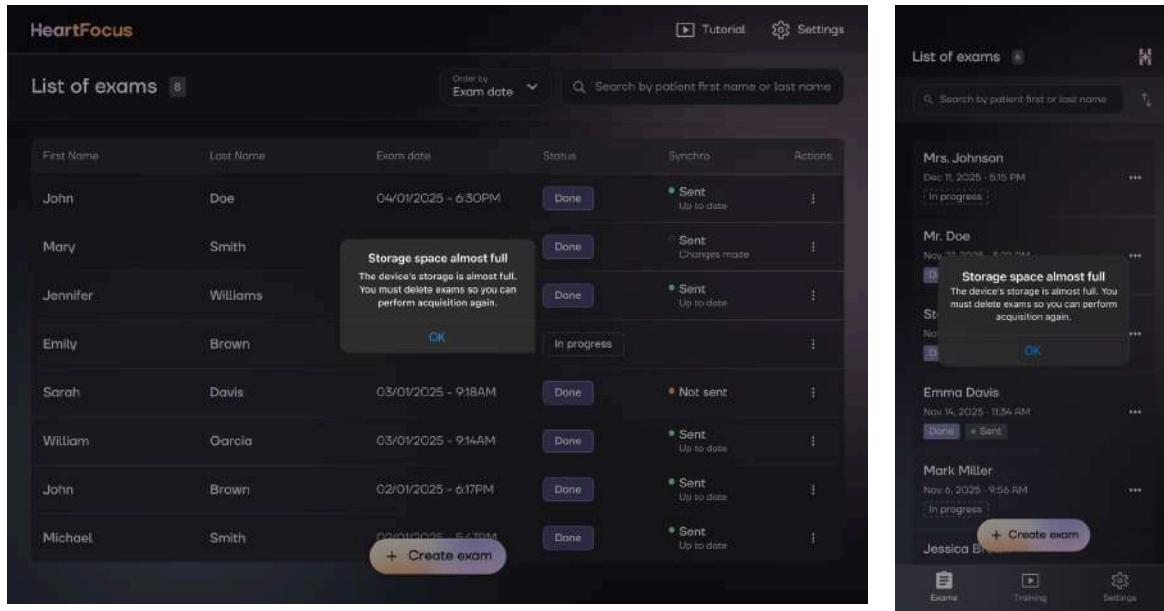

Figure 10 - Storage almost full pop-up

SETTINGS CONFIGURATION

- **About us**

Labeling information is displayed on this page: software version, caution, intended purpose, REF, UDI, Rx Only, quantity, address and contact information of DESKi, date of manufacture, link to user manual, link to privacy policy, medical device symbol, and MR unsafe symbol.

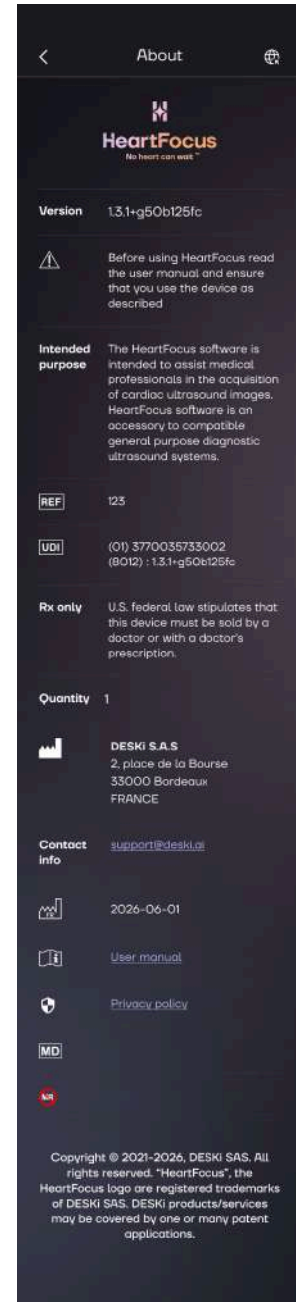
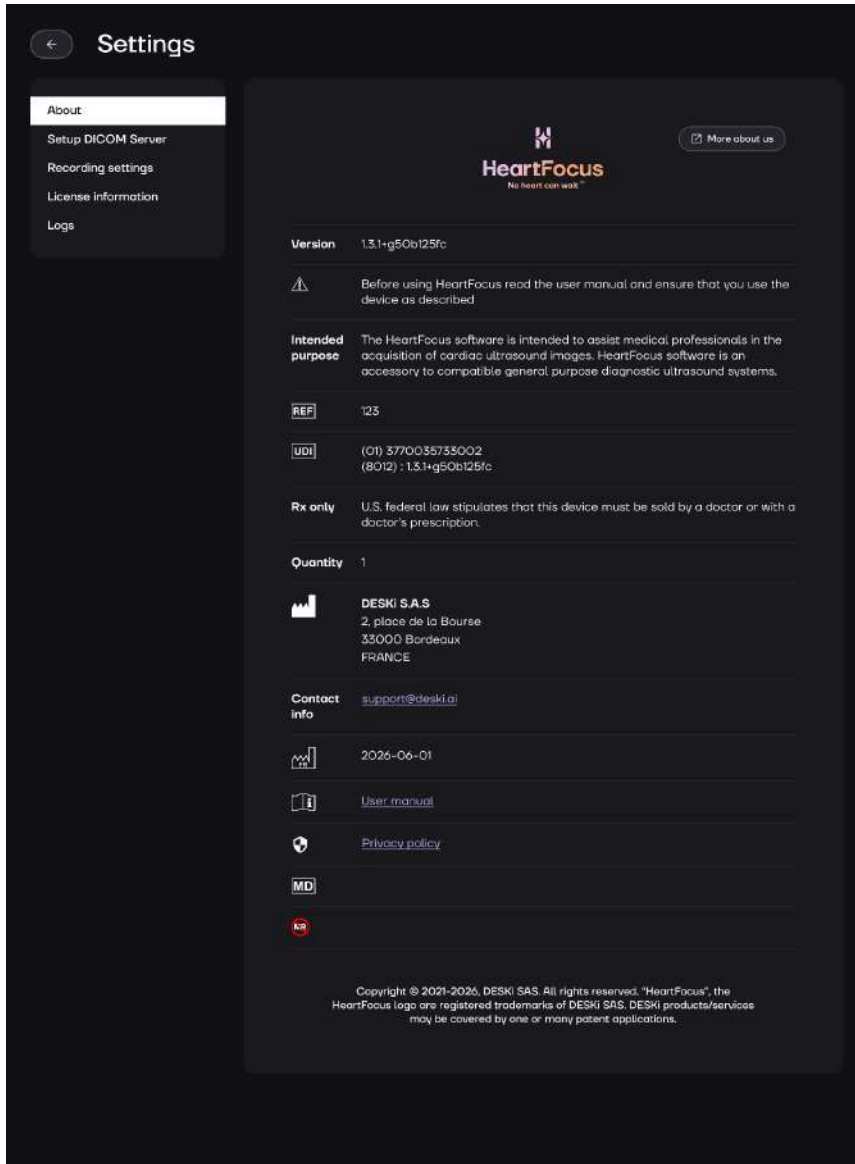









Figure 11 - Labeling information page

The following symbols appear on the About Page of the software application:

Symbol	Definition
	A caution.
	The catalogue number.

	The unique device identification number.
	The product manufacturer, including address.
	The date of manufacture.
	Consult the instructions for use.
	Consult the privacy policy of the software
	This is a medical device.
	MR unsafe symbol.



READ THE MANUAL

Before using HeartFocus, read this manual and strictly observe all precautions and label information.



SAFETY COMMUNICATION

Any incident related to the device should be reported to the manufacturer and the competent authority of the Member State where the user and/or patient is established.

- **Setting up a DICOM Server**

If you wish to send exams performed with HeartFocus to a DICOM server, you must configure it in the “Setup DICOM Server” section. The steps to follow are as detailed below:

- 1. Add a new DICOM Server**

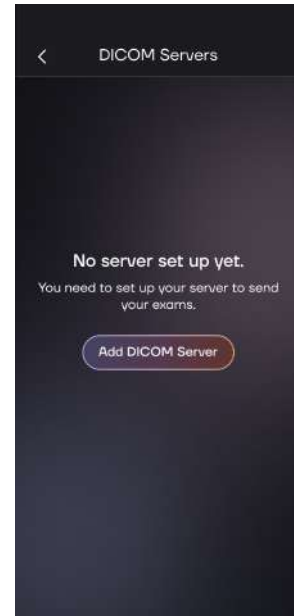
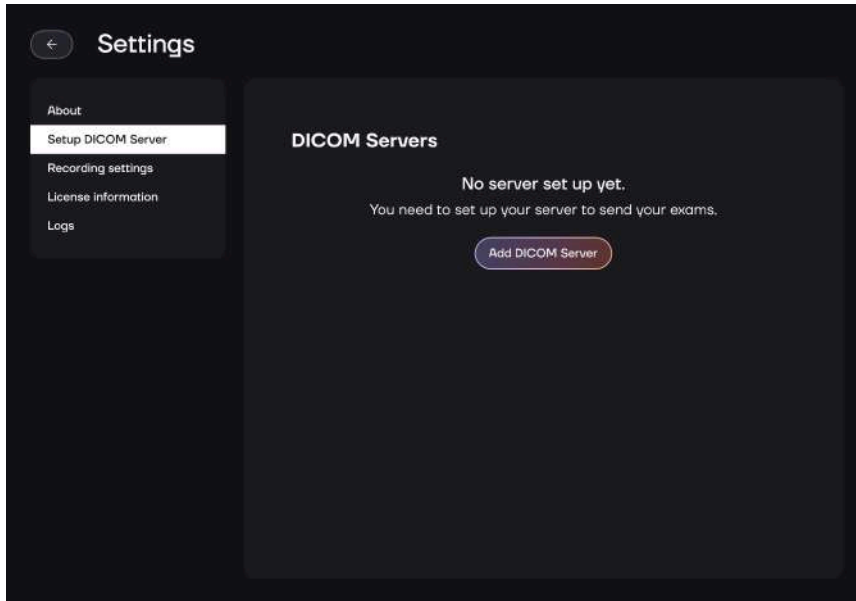

Figure 12 - Setup DICOM Server Page

Click on the “Add DICOM Server” button and fill out the pop-up form with the:

- The server application entity title
- The client application entity title
- The Server IP (a hostname is accepted)
- The Server port
- The option to enable TLS (Transport Layer Security)

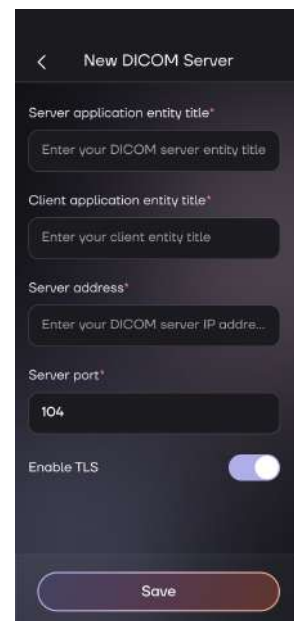
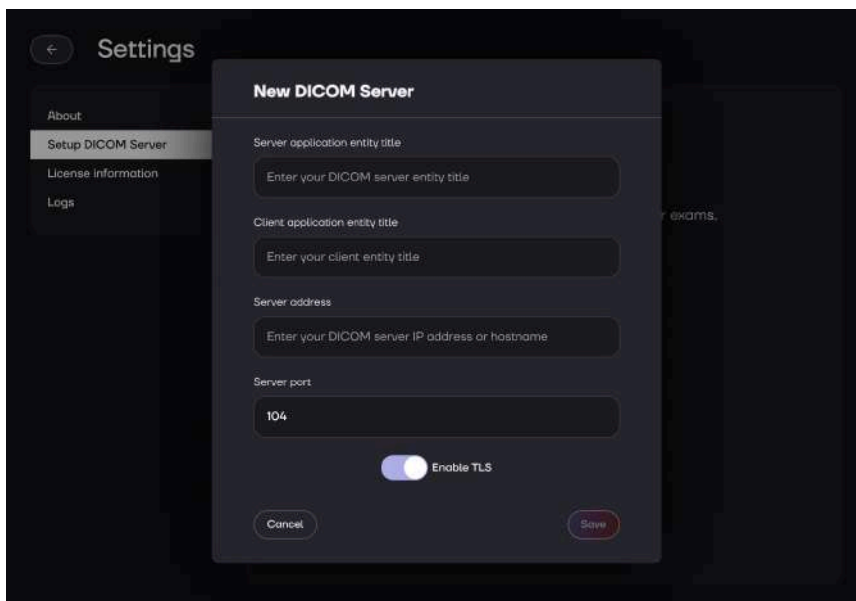

Figure 13 - New DICOM Server configuration

NOTE

INFORMATION SECURITY

When a DICOM server is configured with a disabled TLS parameter, your organization should ensure that the network used by the mobile device is safe to transfer data over a non-encrypted link. Consult with your IT/Security department to ensure that security and patient data protection is in accordance with the policy of your institution.

2. Test the connection to the server

Once added, the DICOM server will appear in the DICOM Servers List. By clicking on the 3 dots button and then pressing “Test”, you can test the connection.

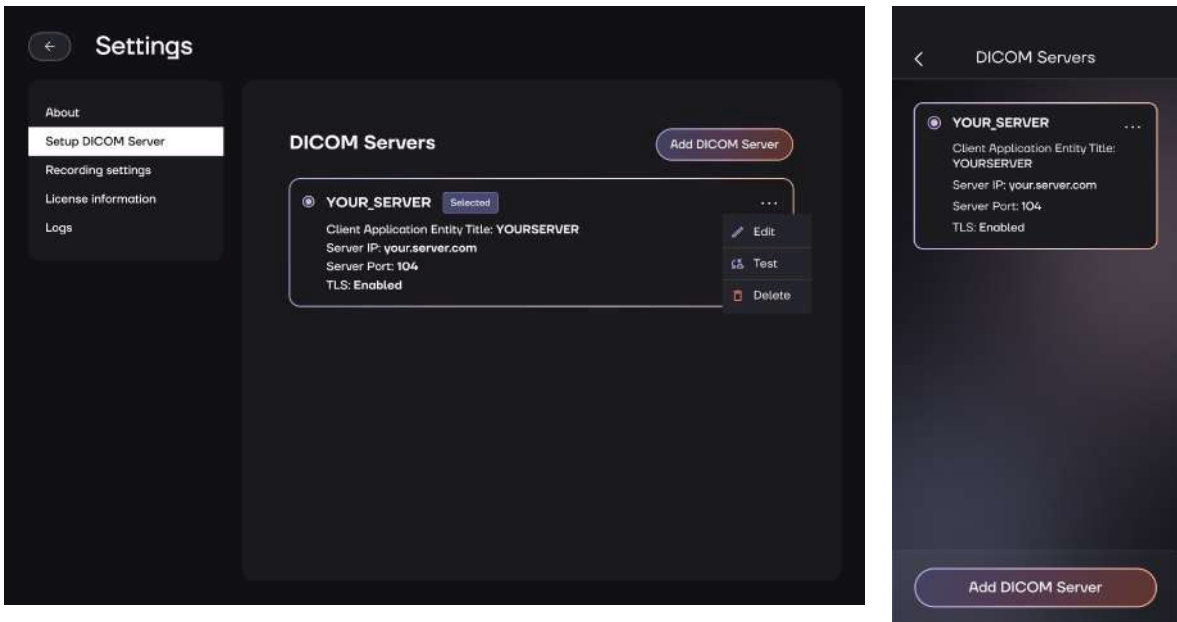

Figure 14 - DICOM Servers list

A success or error message will appear, depending on the result of the test.



Figure 15 & 16 - Success and error message after DICOM server test

NOTE**DATA CONNECTION REQUIRED**

To communicate with the DICOM server, the device should have an active data connection that enables HeartFocus to reach the DICOM server. It will always fail if your device is not connected to the appropriate Wi-Fi network or there is no cellular connection available. In a hospital, the DICOM server may only be available from a local Wi-Fi network.

3. Send exams to a DICOM server

Once communication with a DICOM server has been established, it is possible to send exams performed with HeartFocus to this server (see [EXAM REVIEW](#)).

If multiple servers have been configured, then the sending will be done to the server selected in the settings.

- **Recording settings**

When you are not able to perform an Auto-Record within the selected delay, the Best-Effort Record is proposed with the best quality clip you have made so far. In this section you may modify the delay before the Best-effort Record button appears (in seconds).

NOTE**DELAY BEFORE BEST-EFFORT RECORD**

The delay value used for the clinical study was at 90 seconds.

EXAM CREATION

- **Exam creation form**

To create a new exam on the HeartFocus application, you need to press the “Create exam” button on the Home Page.

You can then enter information about the patient demographics, the administrative details, and the context:

- Patient demographics: first name, last name, sex, date of birth, height, weight
- Administrative details: operator, referring physician, accession number, patient ID
- Context and observations: indications, notes

← New exam

Patient Demographics

First name:

Last name:

Sex:

Date of birth:

Height:

Weight:

Administrative details

Operator:

Referring physician:

Accession number:

Patient ID:

Context and observations

Indications:

Notes:

[Start acquisition](#)

← New exam

Patient Demographics

First name:

Last name*:

Sex:

Date of birth:

Height:

Weight:

Administrative details

Operator:

Referring physician:

Accession number:

Patient ID:

Context and observations

Indications:

Notes:

[Start acquisition](#)

Figure 17 - New exam page

If you start to enter some information on the creation form and then try to return to the home page, a warning message is displayed. It informs you that if you return to the home page, the information you entered on the exam creation page will be lost. A pop-up window will warn you when you try to leave the page when having some information entered.

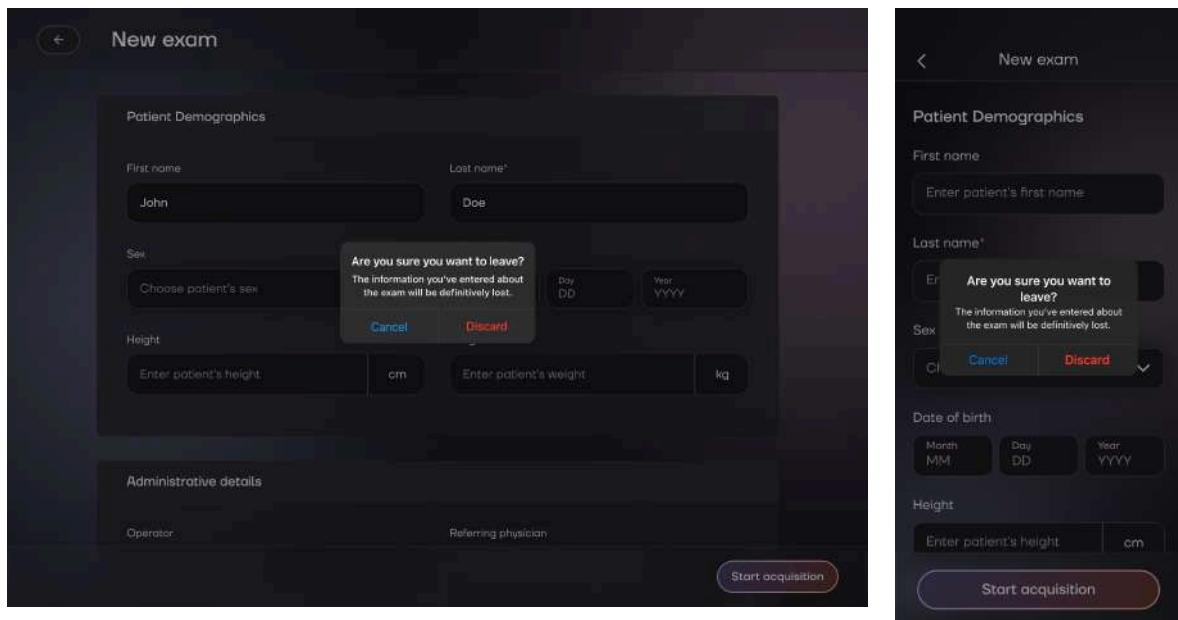

Figure 18 - Warning message when leaving

You can return to the home page or remain on the exam creation form.

- **Required field**

The patient's last name is the only required field in the form, which means you cannot successfully create an exam if you leave it empty. If you press the "Start acquisition" button leaving the patient's last name field empty, an error message will appear and the field will be highlighted in red.

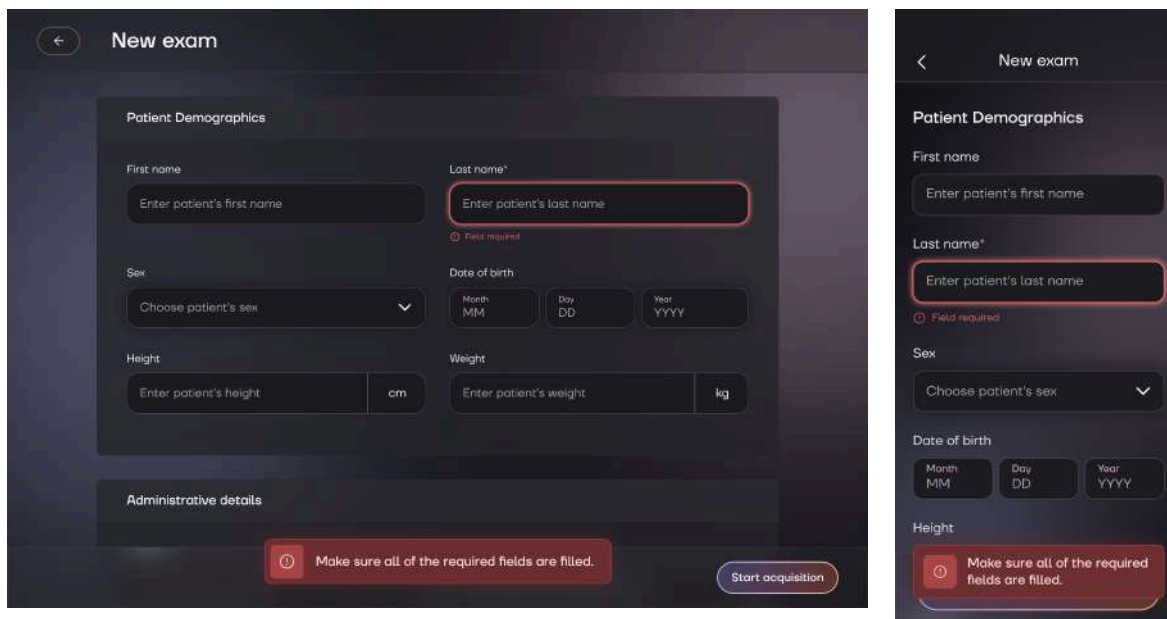

Figure 19 - Missing last name field error message

Once you have started the exam, you can modify or add to the exam information when you validate or send the exam (see [EXAM VALIDATION](#) and [EXAM REVIEW](#)).

- **Specific format**

Some information on the exam creation form needs to be in a specific format :

- The date of birth needs to be written in the Month/Day/Year format
- The weight needs to be expressed in kilograms. The entered value cannot be less than or equal to 0
- The height needs to be expressed in centimeters. The entered value cannot be less than or equal to 0

- **Values range**

Some information on the exam creation form has a specific values range:

- The date of birth must not exceed the current device system date and must not be older than 200 years compared to the current device system date.
- The weight must be at least 0.1 kg and at most 9999 kg.
- The height must be at least 0.1 cm and at most 9999 cm.

- **Values length**

Some information on the exam creation form cannot exceed a certain number of characters:

- The first name and last name combined cannot be longer than 64 characters
- The patient ID cannot be longer than 64 characters

- The accession number must contain at least 1 character and at most 16 characters
- The operator and referring physician cannot be longer than 63 characters
- The notes cannot be longer than 10240 characters

Due to these specific formats, value ranges, and values lengths, some information may be incorrect. The user should verify this data with the patient before creating the exam and during the review process before submission to ensure that all entered information is accurate.

If some values entered do not match the constraints, HeartFocus will display an error message and the relevant fields will be highlighted.

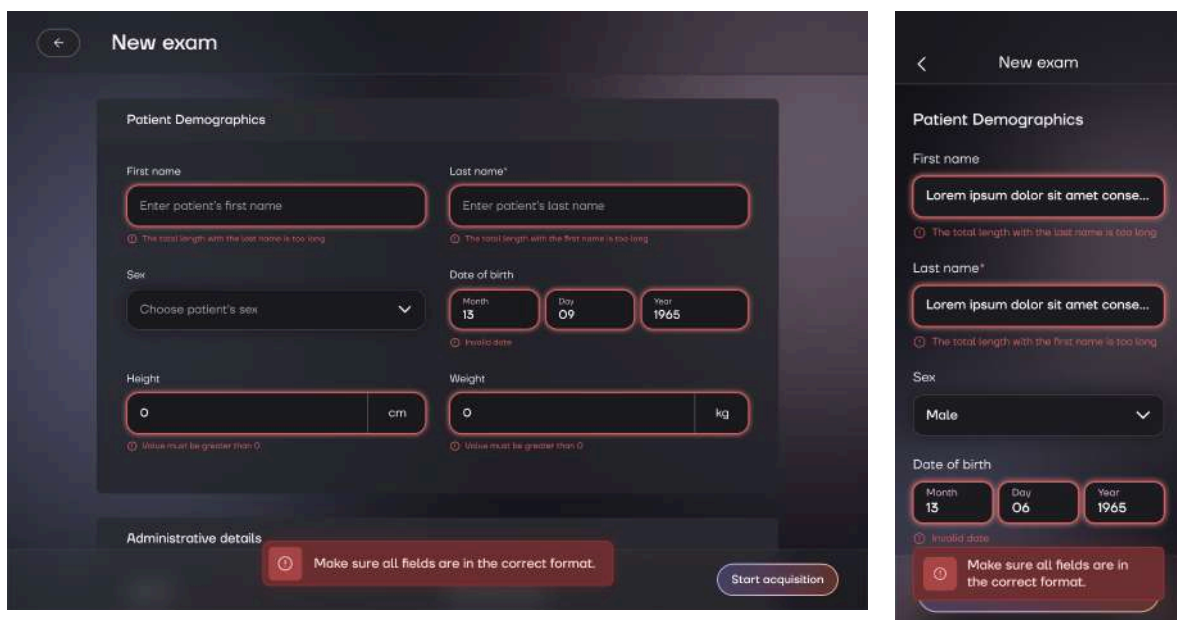

Figure 20 - Wrong format error message

NOTE

iOS User Experience

Some gesture interactions may not perfectly replicate the default iOS experience. Users may notice slight differences in gesture behavior or responsiveness compared to a standard iOS app.

CARDIAC ULTRASOUND IMAGE ACQUISITION

- **Butterfly probe connection**

When accessing the acquisition page, if you have no Butterfly probe connected to your device, a message is shown in the page telling you to do so.

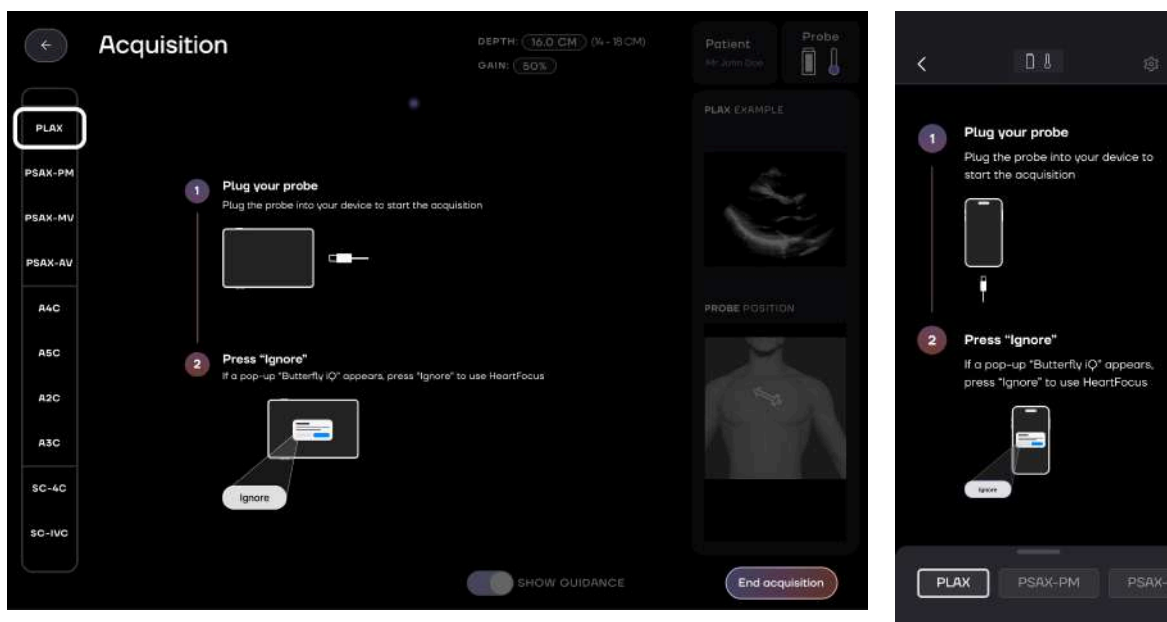

Figure 21 - Plug your probe message

Pay attention to press “Ignore” if a pop-up appears after plugging your probe to make sure you are not redirected outside the HeartFocus app.

Note that, if you are continuing an existing exam, you can review the clips previously acquired and end acquisition without needing to plug an ultrasound probe.

- **Acquisition page overview**

The acquisition page is composed of multiple elements:

1. The list of the 10 standard echocardiographic views. The one framed with a white rectangle is the one you are trying to acquire. You can click on another to change it.
2. The live-streamed image coming from the ultrasound system with the Live Guidance indicator
3. The Auto-Record indicator that fills itself in green when a recording is performed
4. The Best-Effort-Record button that appears after 20 seconds if an Auto-Record has not been saved yet
5. The Manual Record button
6. The suspend guidance button (under the settings subsection on iPhone)
7. The typical depth for the selected view and the current depth (in centimeters) and gain of the probe (under the settings subsection on iPhone)
8. The patient’s first and last name

9. The probe live indicators on the battery and heat
10. An example of the record to perform for the selected view (accessible by swiping the component on iPhone)
11. The indication of the probe position on the patient's torso
12. The "End Acquisition" button

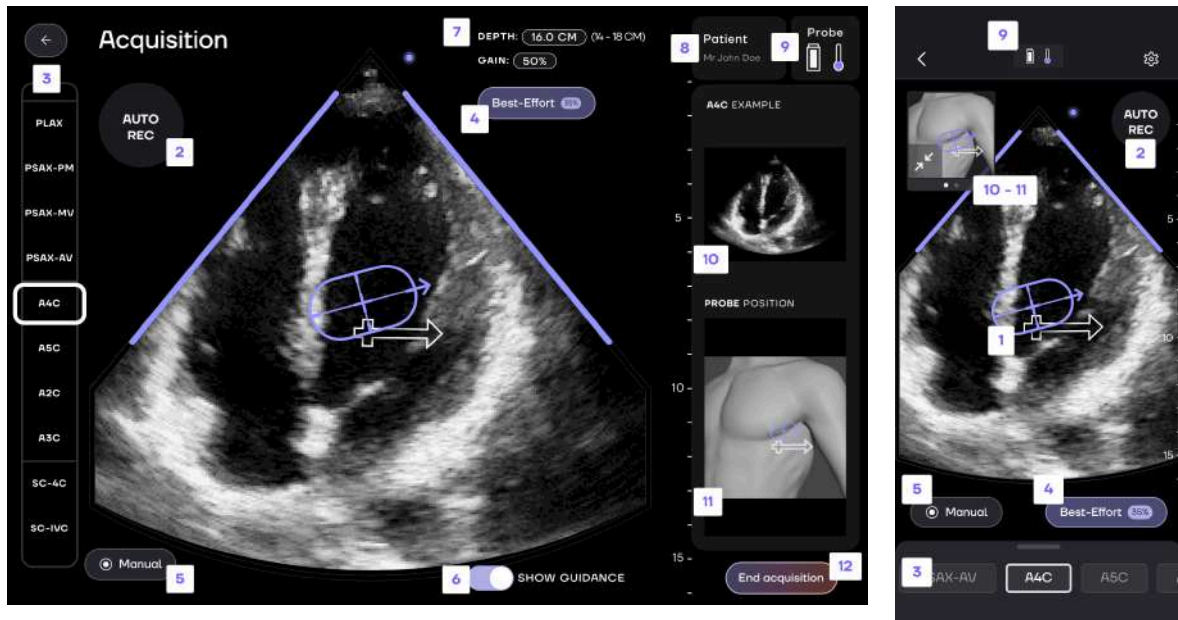

Figure 22 - Overview of the acquisition page

- **Slide-up panel on iPhone**

Specific to the acquisition page on iPhone devices, the sliding panel is where you can find a reminder of the patient's name, the 10 cardiac ultrasound views with their associated record if appropriate and the "End acquisition" button.

By pressing the name of a view or outside the panel, it will close automatically.

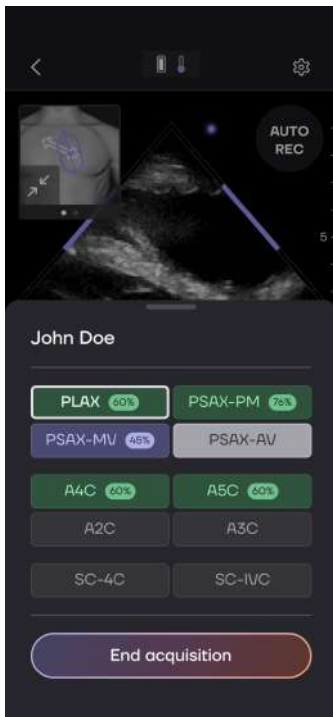

Figure 23 - Slide up panel example

- **Settings subsection**

Specific to the acquisition on iPhone devices, the settings subsection is accessible via the settings icon on top-right of the screen. It contains the suspend the guidance button and currently set values for depth and gain.

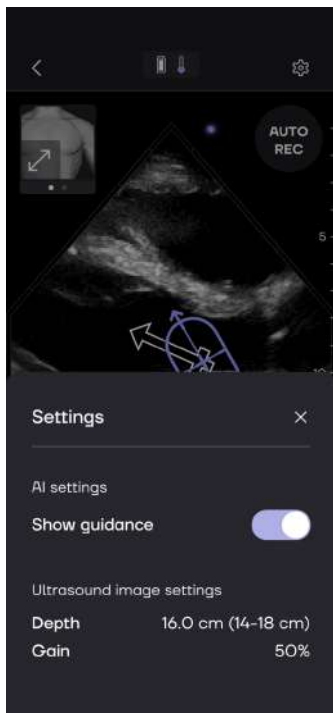
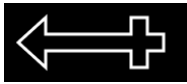

Figure 24- Settings subsection

- **Live Guidance feature**

To perform a cardiac ultrasound exam, it is necessary to find the best position and orientation of the probe to obtain a diagnostic-quality image. HeartFocus predicts the current position of the probe relative to the target position and displays two elements representing these positions :



The static white arrow represents the target position

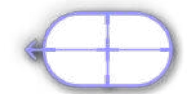

The moving guidance UI composed of an oval and a cross represents the actual probe position

The objective is to superimpose the cross of the Guidance UI on the white arrow.

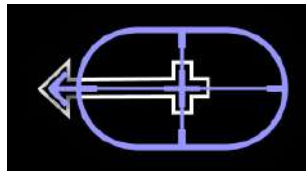

Figure 25 - Visual representation of the objective

To achieve this objective, multiple movements of the probe are possible to reach the target position. The Guidance UI alone shows all movements needed: translation, tilt, and rotation.

You can find in the figures below a correspondence between the Guidance UI and the appropriate movement to do.

Sometimes, a combination of multiple movements is needed to reach the probe's target position.

Translation	Tilt	Rotation

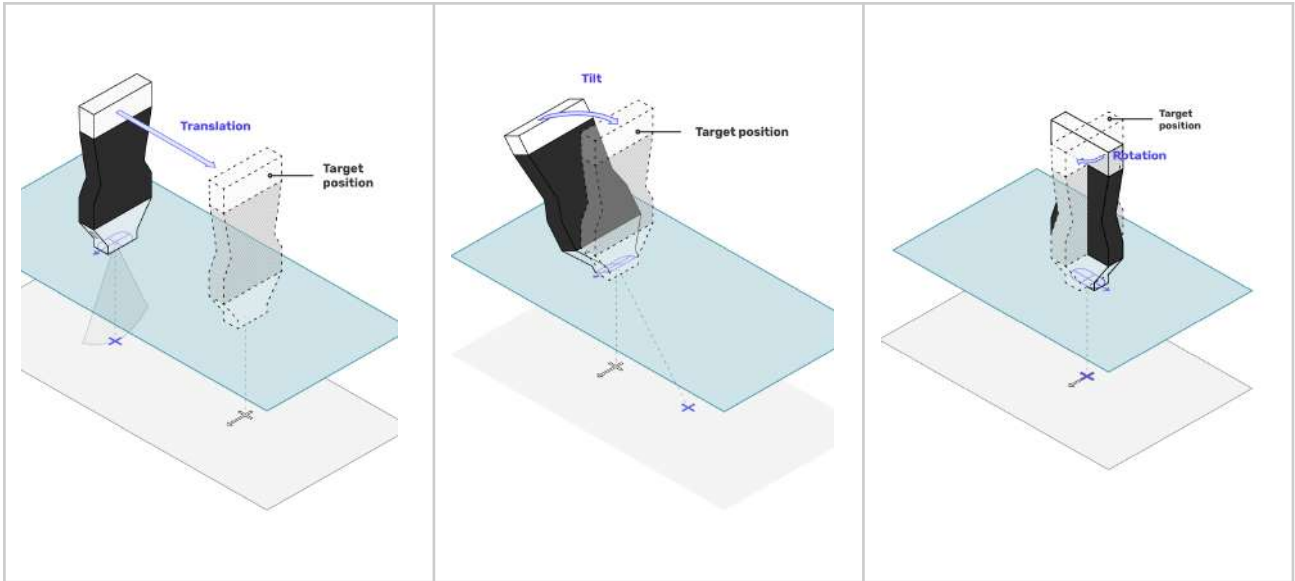

If the ultrasound image does not provide enough visible anatomical parts, the Guidance UI disappears. You should then move the probe to reach a position where there are sufficient anatomical parts visible to be guided again.

If you are a user trained in basic cardiac ultrasound and capable of obtaining a clip of sufficient diagnostic quality without the assistance of the Live Guidance, you may choose to suspend the Guidance in the user interface by clicking on the switch button “Show Guidance” (in the settings subsection on iPhone devices).

- **Diagnostic-Quality View Detection**

When the probe is well positioned and the image is of diagnostic quality, the triangle surrounding the ultrasound image shifts to green. This informs you you may hold the probe position to perform an Auto-Record.

Further when the image quality is getting near, the triangle side bar gets filled by blue bars, indicating you are getting close to diagnostic quality and that you are likely to get a Best-Effort-Record.

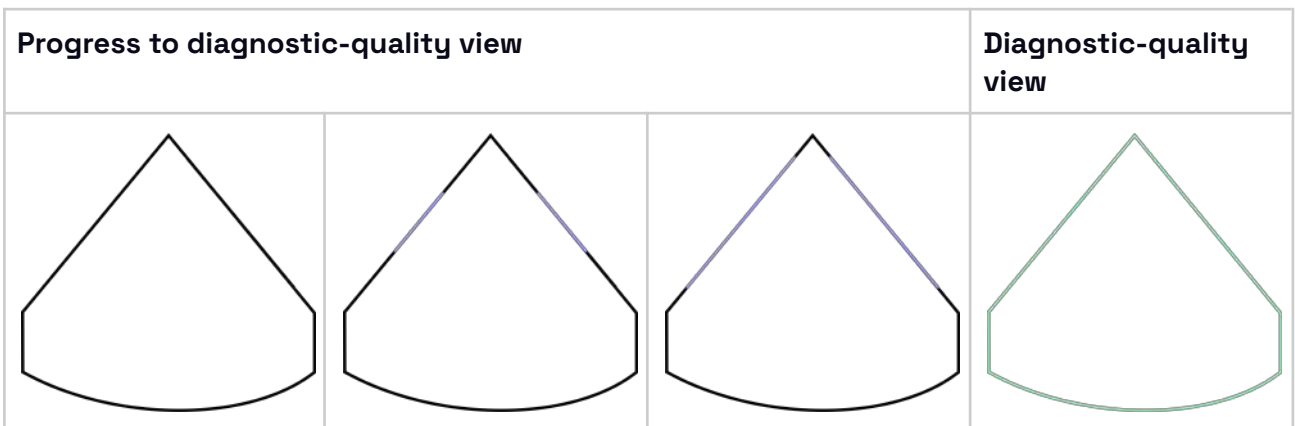

- **Types of recording**

3 different types of recordings are available in HeartFocus: the Auto-Record, the Best-Effort-Record, and the Manual Record. The view navigation bar appearance will change according to the type of recording made for each view: green for an Auto-Record, blue for a Best-Effort-Record, and white for a Manual Record.



ONE CLIP PER REFERENCE VIEW

During acquisition, only one clip per reference view can be recorded; therefore, a manual recording may erase an automatic recording.



Figure 26 - Navigation bar with different types of records

Auto-Record

The Auto-Record is an automatic recording triggered when the quality of the clip is predicted to be of diagnostic quality for 2.5 seconds. When diagnostic-quality images are detected, the Auto-Record UI element starts to fill itself to indicate the recording is ongoing. If diagnostic quality is maintained for 2.2s, the entire Auto-Record UI element is full, and the record is saved. The view navigation bar is updated to show an Auto-Record has been made for the selected view. Finally, an assessment of the quality of the recorded clip is presented as a percentage under the Auto-Record UI element.

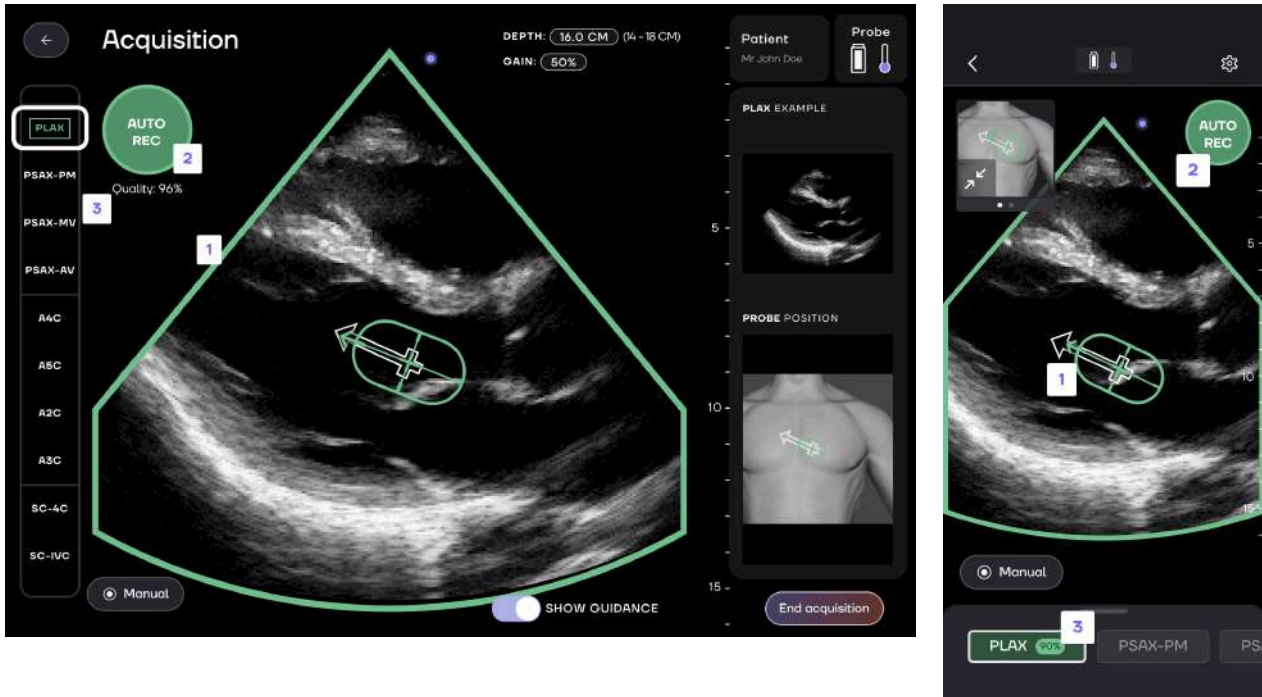

Legend :

- 1. Diagnostic-Quality indicator
- 2. Auto-Record indicator
- 3. Assessed quality

Figure 27 - HeartFocus identifies a diagnostic quality view and automatically records it

Best-Effort-Record

While you are scanning, HeartFocus continually assesses clip quality. If you are not able to perform an Auto-Record, HeartFocus will allow you to record the highest quality clip obtained so far retrospectively. The quality of the clip is always shown in percent. The Best-Effort-Record button is displayed after the delay parameter that can be set up in [SETTINGS CONFIGURATION](#).

In any case, if you have not recorded a clip for a given reference view and a Best-Effort-Record is available, it will be automatically saved when ending an exam.

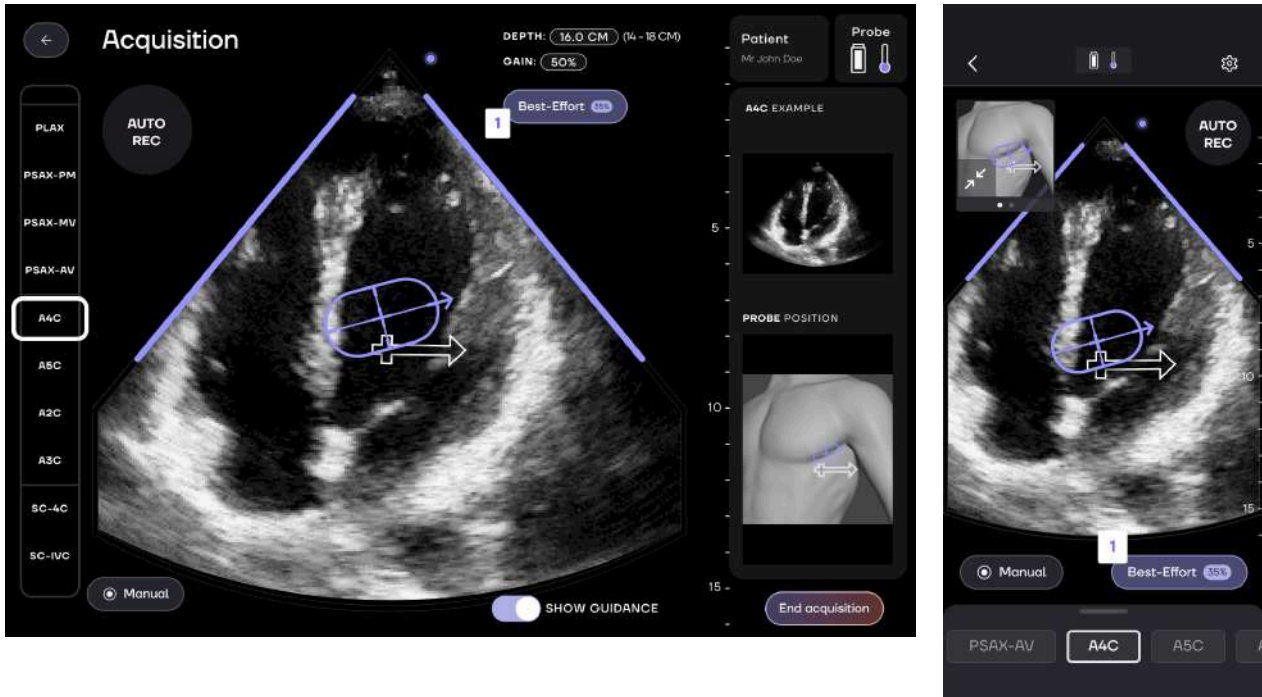

Legend :

1. BER button

Figure 28 - HeartFocus has recorded the highest quality clip obtained and allows you to save it

If you click on the “Best-Effort-Record” button, you will then be able to review the clip obtained and choose to save it or go back to the acquisition.

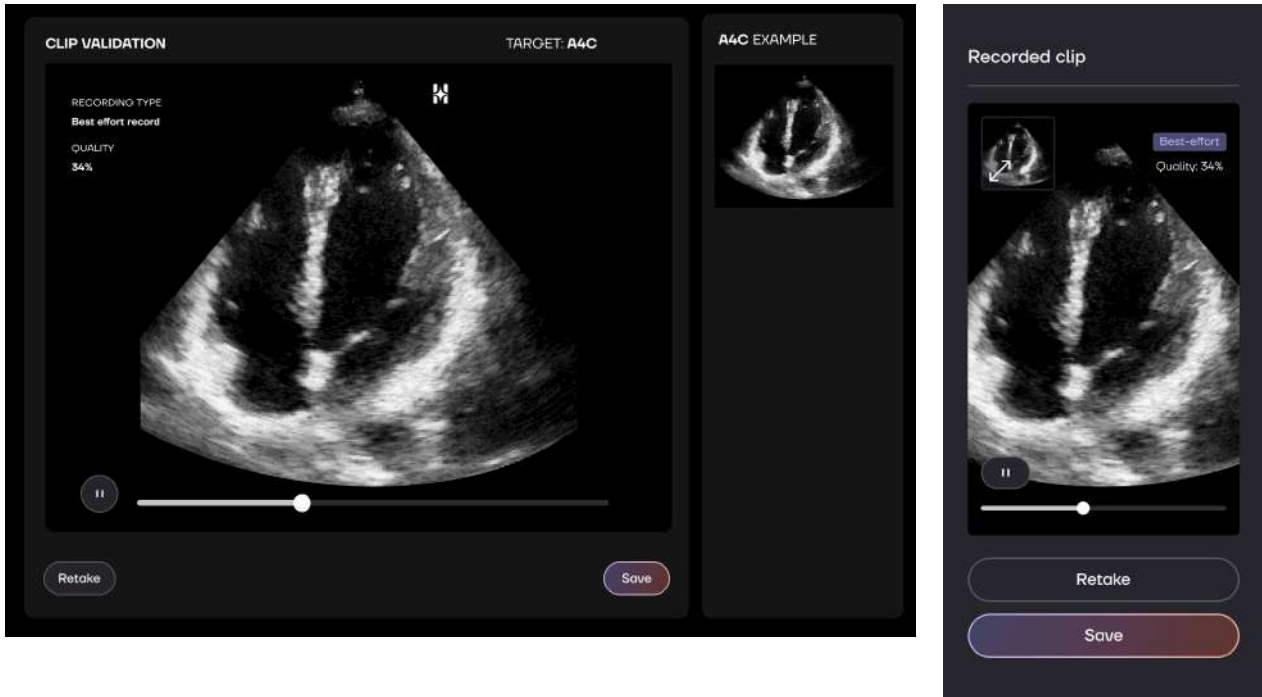

Figure 29 - Clip validation after a BER

Manual Record

By clicking on the “Manual Record” button, HeartFocus will capture retrospectively the 2.5 last seconds. However, there will be no assessment of the clip quality by an AI algorithm. You will then be able to review the clip captured and choose to save it or go back to the acquisition.

NOTE

MANUAL RECORD POSSIBLE AFTER 2.5 SECONDS

The manual record button will be enabled only 2.5 seconds after the start of acquisition or any change in depth/gain.

- **Managing depth and gain**

To change the depth of the image you can slide your finger from top to bottom to reduce it and from bottom to top to increase it. The current value is displayed on top of the screen or in the settings subsection in centimeters. The initial value is preset for each view.

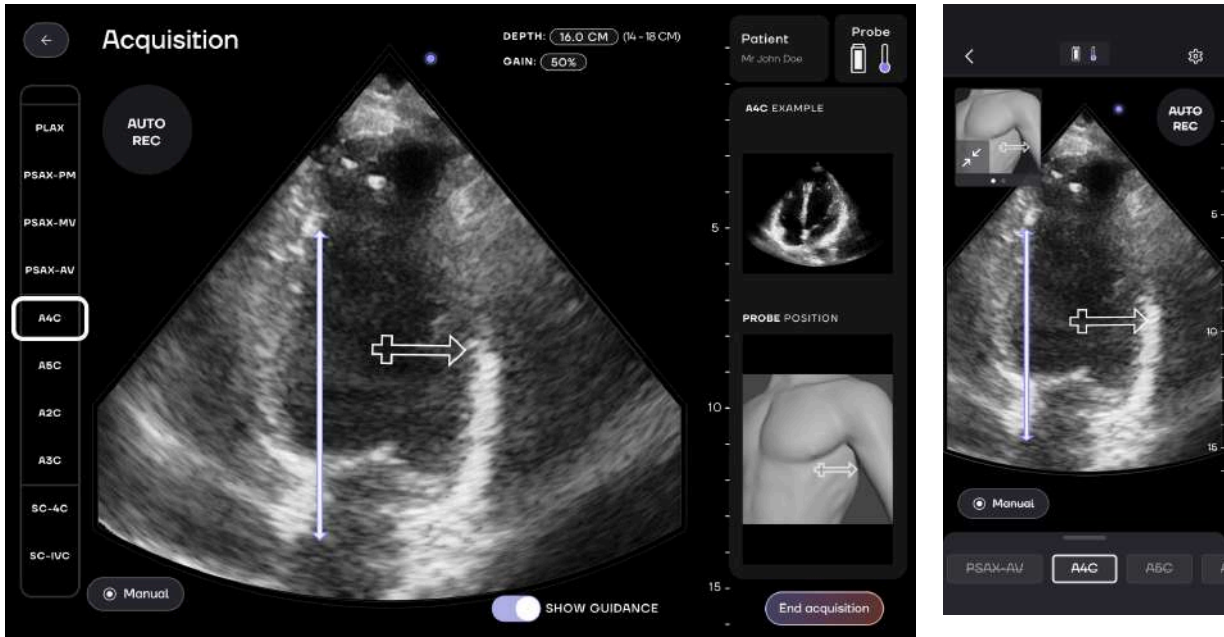

Figure 30 - Slide your finger upper and lower to change the depth

To change the gain of the image you can slide your finger from right to left to reduce it and from left to right to increase it. The current value is displayed on top of the screen or in the settings subsection as a percentage. 50% is the initial value.

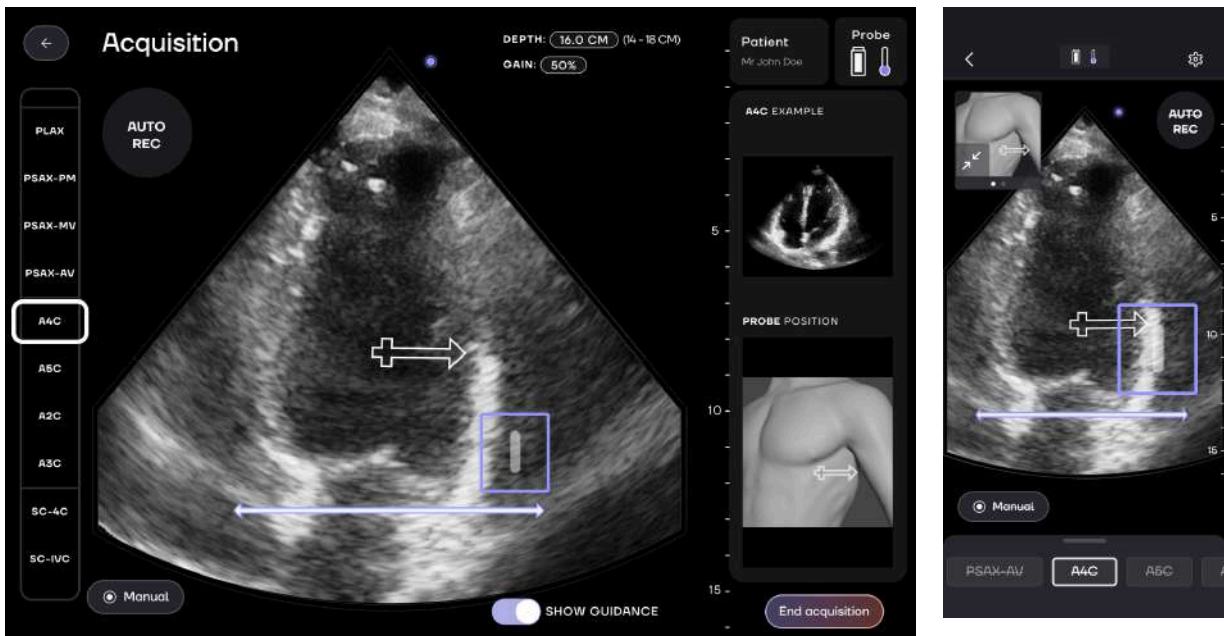

Figure 31 - Slide your finger left and right to change the gain

- **Probe temperature and battery levels**

Directly on the acquisition page, two icons are displayed to represent the current temperature and battery levels of the probe. The fill color of these icons changes depending on the criticality of the corresponding value.

The battery icon's fill color reflects the current battery probe level. Once the level reaches a critical threshold, the fill color changes to red.



Figure 32- Battery icon evolution

The thermometer icon's fill color reflects the current temperature probe level. Once the level reaches a warning threshold, the fill color changes to orange. Once the level reaches a critical threshold, the fill color changes to red.

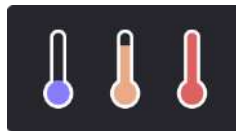

Figure 33- Temperature icon evolution

EXAM VALIDATION

Once the acquisition of the echocardiographic views is finished, you can access the exam validation page by clicking on the “End Acquisition” button on the Acquisition page. On iPhone devices the button is accessible by sliding up the panel at the bottom of the screen.

A specific screen allows you to view at the same time the exam information you entered at its creation and all records made in the exam.

On iPad, you can directly review all the clips. On iPhone, you can press a view name to access clip review.

If needed, you can go back to the acquisition if any of the recorded clips don't meet your requirements.

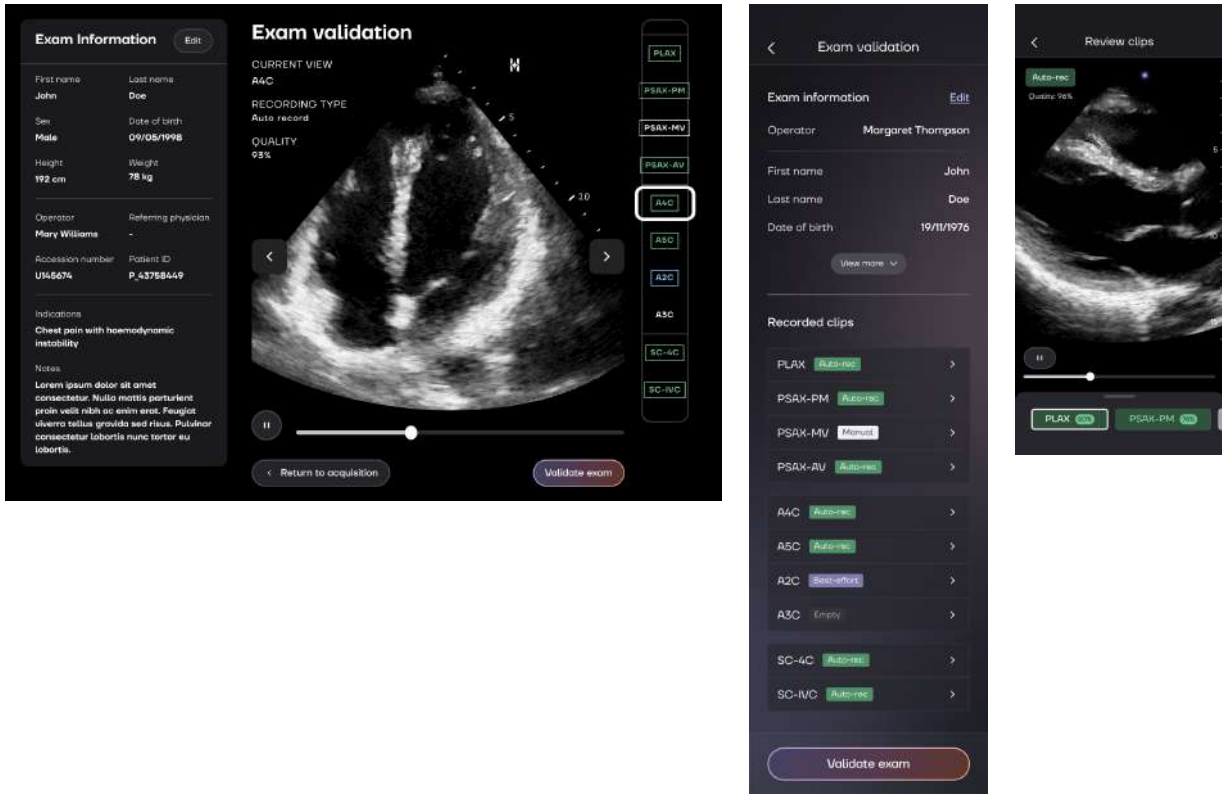

Figure 34 - Exam validation and review clips pages

You can edit the exam information by clicking on the button “Edit”, you will then be redirected to an information editing page.

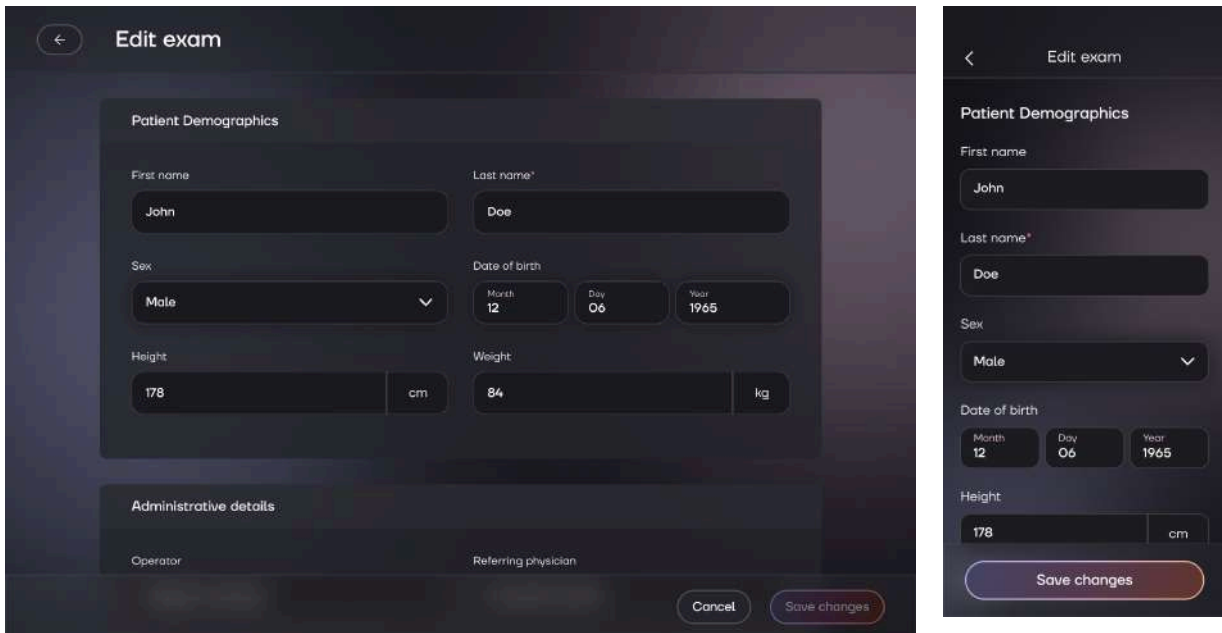

Figure 35 - Exam information edition page

On this page, you can modify all the entered information. To save your edits, click on the “Save changes” button. Otherwise, you can go back to the validation page by clicking on the “Cancel” or the arrow icon button.

Once you have finished verifying all the information, you can click the “Validate Exam” button. Validating the exam prevents clips from being lost since once validated, clips can no longer be deleted or modified. However, the clinical input from the exam creation form stays editable on the exam review page (see [EXAM REVIEW](#)).

EXAM REVIEW

Once the exam is validated, you can send it to a DICOM server. To do so, you need to click on the “Open” button on the actions list of the home page to access the exam review page. This page allows you to review at the same time the exam information you entered and all the clips you acquired. However, clips can no longer be modified at this stage of the process.

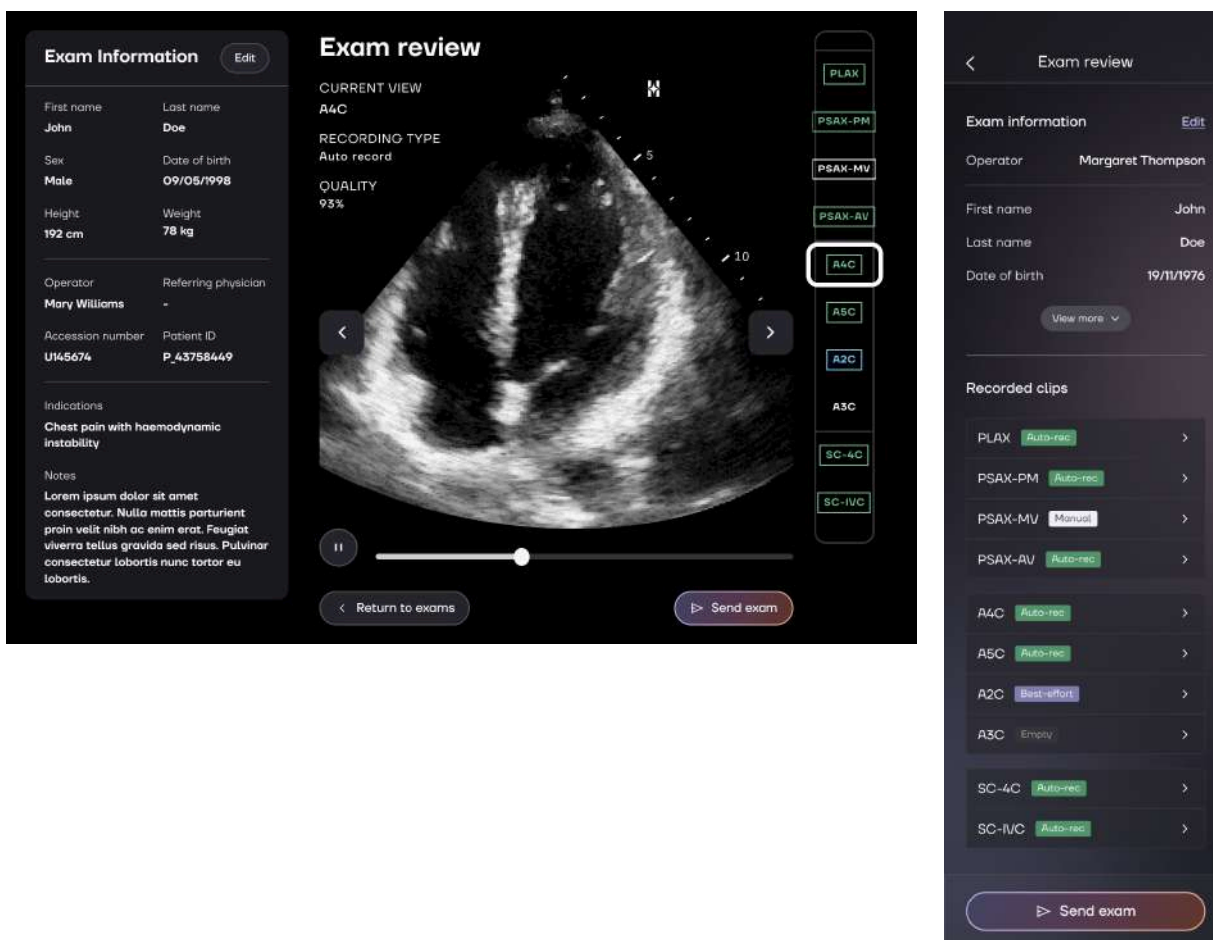

Figure 36 - Exam review page

You click on the button “Send exam” to send the exam to the DICOM server configured in the parameters of HeartFocus (see [SETTINGS CONFIGURATION](#)).

NOTE

DATA CONNECTION REQUIRED

To communicate with the DICOM server, the Mobile device should have an active data connection that enables HeartFocus to reach the DICOM server. It will always fail if your device is not connected to the appropriate Wi-Fi network or there is no cellular connection available. In a hospital, the DICOM server may only be available from a local Wi-Fi network. The transfer duration depends on the data connection speed with the DICOM server. A 25 Mbps connection will lead to a 1 minute transfer.

If your device is not connected to the Internet or if you haven’t configured any DICOM server, the send will fail and HeartFocus will show an error message.



Figure 37 - Error message on exam sent

If the exam is sent with success, a message will appear confirming it.

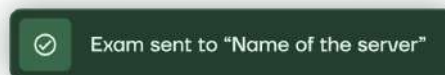

Figure 38 - Success message on exam sent

If your exam has already been sent, a pop-up message will appear to warn you. You can then choose between still sending the exam or canceling your action.

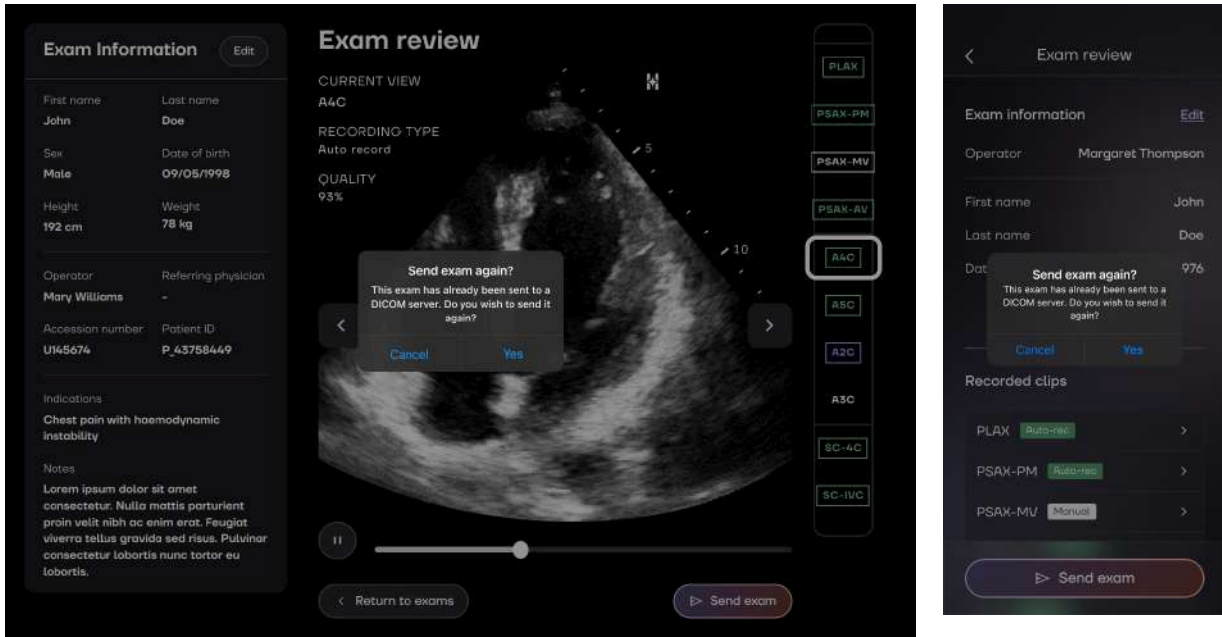

Figure 39 - Exam already sent pop-up

NOTE

EXAM SENT MULTIPLE TIMES

If you send the same exam multiple times, each one of them will have a different ID. Thus, if you send them to a unique DICOM server, the exam will be duplicated and not overwritten.

Likewise, if the same exam is sent on multiple DICOM servers, it won't have the same ID on all servers.

If an exam that has already been sent is modified (for example, by changing the patient's information) and resent, a duplicate of the exam for the same patient will be created. It will be the user's responsibility to manage this situation.

PRECAUTION

QUALIFIED MEDICAL PROFESSIONAL

The images and data acquired using the device are to be interpreted only by qualified medical professional

UNINSTALLING THE APP

On your device, touch and hold the HeartFocus app icon and press "Remove App". In the confirmation pop-up, press "Delete App". When the app icon disappears, the process is completed.

CHAPTER 6 - CYBERSECURITY

SECURITY ISSUES

Please contact your organization's IT or Security teams if you suspect you were the target or victim of a phishing attempt or other cybersecurity attacks or if you have any concerns regarding the safety and integrity of your device. Security issues within the DESKi product can be reported to our security team via the email security@deski.ai by following the Coordinated Vulnerability Disclosure process detailed here:

<https://heartfocus.ai/security/cvd>. Security issues identified within the DESKi application, as well as their remediation guidelines, will be communicated through email to users that have an active account.

USER'S CYBERSECURITY RESPONSABILITIES

- **Maintain a Secure Environment:** When online, ensure the mobile device is operated on a secure network with appropriate access controls, such as WPA2 or a more advanced security protocol. Avoid using the application on public or untrusted Wi-Fi networks.
- **System Updates:** Keep the mobile device's operating system (iOS/iPadOS) and the HeartFocus application updated to the latest versions as soon as they are available to ensure all security patches are applied.
- **User Authentication:** Implement and maintain strong, unique passcodes or biometric authentication on the mobile device to prevent unauthorized access.
- **Malware Protection:** While resource-intensive antivirus software should be avoided during active scanning, ensure the mobile device is periodically scanned for malware using a reputable security application when HeartFocus is not in use.
- **Secure Decommissioning:** Before disposing of or repurposing the mobile device, you must securely erase all data by performing a factory reset after uninstalling the HeartFocus application to ensure no Protected Health Information (PHI) remains.
- **Incident Reporting:** Immediately report any suspected security incidents, vulnerabilities, or unusual application behavior to your institution's IT department and to DESKi support at security@deski.ai.

AUDIT LOGS

HeartFocus includes a logging feature designed to enhance security and traceability. It records key actions within the app, helping to monitor activity and support the investigation of potential issues, especially those related to cybersecurity risks.

The key actions are the following:

- Exam operations such as creation, deletion, validation, reviewing
- Exam's clip deletion
- DICOM server configuration operations such as creation, deletion and update

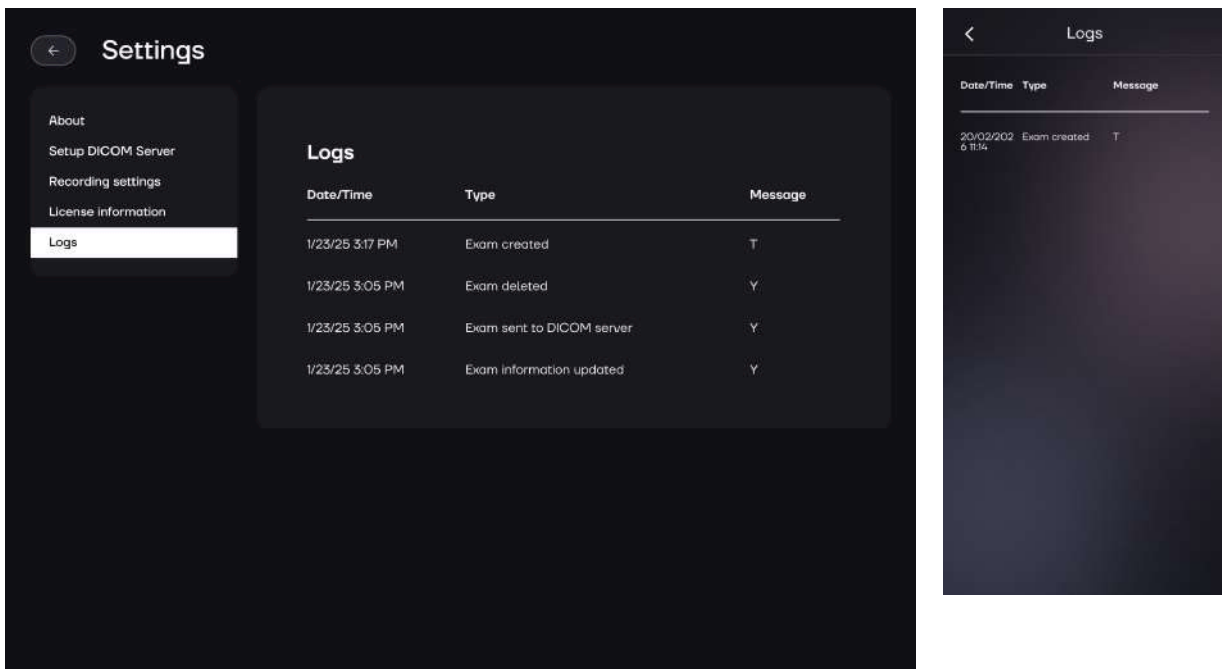

Figure 40 - Audit logs showing key actions on Exam, Clip and DICOM server configurations

- **Accessing the Logs**

Navigate to the About page in the app.

Select the Logs section. Here, you will find a detailed list of actions performed within the app.

- **Retention of the logs**

The logs are stored for 15 days.

After 15 days, logs are automatically deleted.

- **Use of the logs for forensic purposes**

The logs provide a detailed record of important actions, making it possible to investigate and understand any irregularities or cybersecurity incidents that may occur. This feature is intended to help users and administrators trace events and detect potential threats, or understand what happened in the last 2 weeks.

The logs are sorted from the most recent event to the oldest one.

Each log contains the following information:

- Date/Time of the event
- Type of the event indicating the key action that has been performed
- Message that provides an additional context for the event

The message attribute is set depending on the key action:

- If the key action is exam related then the message is composed of the first letter of the first name followed by the first letter of the last name of the patient
 - Or only the first letter of the last name of the patient, if no first name was provided for the exam's patient
- If the key action is clip related then the message is the same as for an exam plus the name of the view (PLAX, PSAX-MV, etc...)
- If the key action is DICOM server configuration related, the message contains the value of the Server IP

CHAPTER 7 - TROUBLESHOOTING

The following section describes the possible scenarios that may occur when using HeartFocus, and how to resolve them.

If you encounter a **persisting problem** that you can't solve, you can contact our support team via email at support@deski.ai.

PROBE TROUBLESHOOTING

When plugging your ultrasound probe to the HeartFocus App, you can encounter several error messages related to your probe. Here are some tips for resolving errors.

Error message	Root cause	Action(s) to do
Incompatible probe	The probe you have connected to the mobile device is not a Butterfly iQ+ or iQ3 model.	Connect a probe model compatible with the HeartFocus app (Butterfly iQ+ or iQ3 only)
Unavailable probe	The probe has reached its maximum temperature	Let the probe cool down before connecting it again
	The battery level of the probe is too low	Recharge the probe before connecting it again.
	The probe is not registered with Butterfly.	Open the Butterfly app and register your probe. (For further information, refer to the probe user manual)
Probe charging	The probe connected to the mobile device is also charging at the same time.	Disconnect the probe from its charger.
Critical Battery Level	The battery level of the probe is too low	Recharge the probe before connecting it again.
Oops.. A problem occurred	An unexpected error occurred	Disconnect and reconnect the probe. You can also restart the HeartFocus app.

LICENSE TROUBLESHOOTING

When plugging your ultrasound probe to the HeartFocus App, you can encounter several error messages related to your license. Here are some tips for resolving errors.

Error message	Root cause	Action(s) to do
Internet connection required	Your mobile device is offline, and an internet connection is required to retrieve or update your license information.	Connect your mobile device to the internet.
No license found	Your probe isn't linked to any license	If you haven't purchased any license for the HeartFocus app, access heartfocus.ai and purchase one.
		If you have purchased one or more license(s), you probably didn't link your probe to it. Access portal.heartfocus.ai where you may link licenses to your compatible probes using their serial number.
You're about to lose access to HeartFocus	Your license auto-renewal has been cancelled.	Access portal.heartfocus.ai to reactivate the auto-renewal of your license before it expires.
	Your license auto-renewal payment has failed.	Access portal.heartfocus.ai to update your payment method before the end of the grace period we are granting you.
Something's wrong with your license	An unexpected error occurred with your license.	Contact support@deski.ai
Oops... Something went wrong	An unexpected error occurred while retrieving your license data.	Contact support@deski.ai

LIVE GUIDANCE DOESN'T SHOW

If you have been scanning for while without seeing the Live Guidance UI, follow and review the following protocol for acquiring an image:

- Make sure the position and orientation of the probe corresponds to the target position displayed on the 3D torso (see [Figure 22 - Overview of the acquisition page](#))
- Verify that the current depth is suitable for the selected view
- Manipulate the probe's angle to make sure it points towards the heart
- Manipulate the patient to make sure intercostal spaces are opened at the maximum
- Guide the patient with their respiration

EXAM CAN'T BE SENT

If you have been trying to send an exam but never succeeded, try following the next steps :

- Make sure your device is connected to the Internet or to the appropriate Wi-Fi network
- Verify that a DICOM Server has been configured in the settings of HeartFocus and test the connection to it (see [SETTINGS CONFIGURATION](#))
- If you still can't connect your device to a DICOM server contact your IT department to make sure you have made all the necessary configuration

Note that you can't send empty exams. An error message will appear if you try to do so.