



LAING INNOTECH

Installation and operating instruction

LTC Series

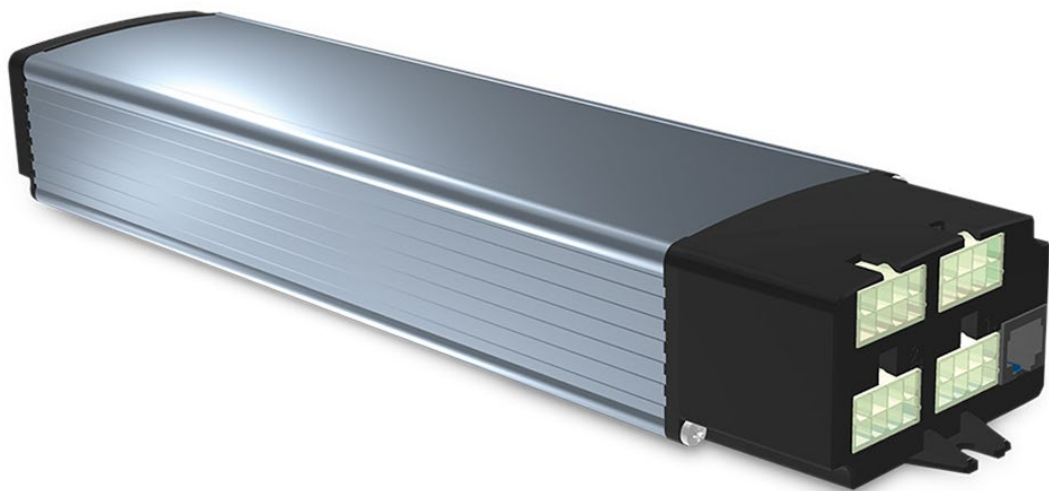

Table of contents

1 The LTC table controller	- 5 -
1.1 Application	- 5 -
1.2 For whom this document is prepared for.....	- 5 -
1.3 Preconditions for the use of this document	- 5 -
1.4 Safety instructions	- 5 -
1.4.1 Indications for all Laing Table Controllers and all accessories (products).....	- 6 -
1.4.2 Indications for the operation of height adjustable tables	- 6 -
1.5 Design of the table controllers	- 6 -
1.6 Specifications	- 7 -
1.6.1 Controller for mains connection LTC	- 10 -
1.6.2 Controller for DC-operation LTCD	- 12 -
1.6.3 Controller for battery-operation LTCB.....	- 12 -
1.7 Environmental conditions	- 13 -
1.8 Dimensions controller for mains connection LTC.....	- 13 -
1.9 Dimensions controller for DC-operation LTCD.....	- 14 -
1.9.1 LTCD.....	- 14 -
1.9.2 LTCD Rev. 2 (from 2025).....	- 14 -
1.10 Dimensions controller for battery-operation LTCB	- 15 -
1.11 Options	- 15 -
1.12 Delivery contents	- 15 -
2 Installation of the controllers	- 15 -
2.1 Battery controller LTCB	- 16 -
2.2 Controller with GyroSense / GraviSense	- 16 -
2.3 Installation of the control panels.....	- 17 -
2.3.1 Rectangular control panels	- 17 -
2.3.2 Oval control panels	- 17 -
2.4 Electrical connection	- 18 -
2.4.1 Connectable Motors.....	- 19 -
2.4.2 Pin assignment controller.....	- 19 -
2.5 Connection of the motors	- 20 -
2.6 Connection of the control panels and other control options.....	- 20 -
2.6.1 Control panels with cable.....	- 20 -
2.6.2 Connection of two control panels	- 21 -
2.6.3 Connection of up to 11 control panels	- 21 -
2.7 Wireless control panel LM4RW	- 22 -
2.7.1 Connection.....	- 22 -
2.7.2 Mounting the wireless control panel.....	- 22 -
2.7.3 Pairing the control panel and the controller	- 23 -
2.7.4 Battery change	- 24 -
2.8 Mains connection LTC.....	- 24 -
2.9 Connection LTCD.....	- 24 -
2.10 Connection, battery change and charging of the LTCB	- 25 -
2.11 Preconditions for the start of operation of the controller	- 26 -
3 Start of operation	- 27 -
3.1 Current based collision detection	- 27 -
3.2 GyroSense based collision detection	- 27 -
3.3 GraviSense based collision detection	- 28 -
3.4 Adjusting the sensitivity level by the user.....	- 28 -
3.5 Reference run.....	- 29 -
3.6 Determining the stroke by the reference run.....	- 30 -
3.7 Safety zone.....	- 30 -
3.8 Safety Input	- 31 -
3.9 Automatic motor recognition.....	- 32 -

4 Control through control panels	- 33 -
4.1 All Control panels	- 33 -
4.2 Control panels with memory keys	- 33 -
4.3 Recall memory position with 2-Button control panel without height indication	- 33 -
4.4 Control panels with height indication	- 34 -
4.5 Configuration of the controller through "LM" control panels (control panels without height indication).....	- 34 -
4.5.1 Store memory positions with "LM" control panels	- 34 -
4.5.2 User height limit adjustment by "LM" control panels	- 34 -
4.5.3 Minimum stroke	- 35 -
4.5.4 Changing the sensitivity of the collision detection by "LM" control panels	- 36 -
4.5.5 Initiating a reference run by "LM" control panels	- 36 -
4.6 Configuration of the controller through "LD" control panels (with height indication)...	- 37 -
4.6.1 Operation of "LD" control panels without memory keys	- 37 -
4.6.2 Storing memory positions by "LD" control panels	- 37 -
4.6.3 Activating button mode of the memory keys by "LD" control panels.....	- 37 -
4.6.4 User height limit adjustment by "LD" control panels.....	- 38 -
4.6.5 Stroke limitation adjustment by "LD" control panels.....	- 39 -
4.6.6 Minimum stroke	- 41 -
4.6.7 Changing the sensitivity of the collision detection by "LD" control panels	- 41 -
4.6.8 Initiating a reference run by "LD" control panels	- 42 -
4.6.9 Adjusting direction of the reference run.....	- 42 -
4.6.10 Changing height indication from centimeter to inch by "LD" control panels.....	- 42 -
4.6.11 Entering the info menu by "LD" control panel.....	- 43 -
4.6.12 Shifting the height indication by "LD" control panels	- 43 -
4.6.13 Defining the rounding for height indication by "LD" control panels	- 44 -
4.6.14 Resetting user settings by "LD" control panel	- 44 -
4.6.15 Activating the BLE module	- 45 -
4.6.16 Resetting the controller name	- 45 -
4.6.17 Activating the pairing mode	- 46 -
4.6.18 Deleting connections to wireless control panels	- 46 -
4.6.19 Resetting the private mode for the app	- 47 -
4.6.20 Entering the option menu by "LD" control panel.....	- 47 -
4.6.21 Resetting the number of connected motors	- 48 -
4.6.22 Resetting the Safety Adapter	- 49 -
4.6.23 Setting the starting point for the safety zone.....	- 49 -
4.6.24 Displaying the last error by "LD" control panel	- 50 -
4.7.25 Synchronization of 2 controllers by LD control panel	- 51 -
5 Synchronization of up to 6 controllers by HUB.....	- 52 -
5.1 Port designation	- 53 -
5.1.1 HUB LH-06	- 53 -
5.1.2 HUB LH-06 Rev. 2.....	- 54 -
5.2 Configuration.....	- 54 -
5.2.1 Connecting the controllers to the HUB	- 54 -
5.2.2 Remaining ports	- 55 -
5.3 HUB startup	- 55 -
5.4 Operation	- 56 -
5.5 Connecting a PC to the HUB	- 56 -
5.6 Exchanging a controller	- 56 -
5.7 HUB Menu handling.....	- 57 -
5.7.1 Restarting the HUB by „LD“ control panel.....	- 57 -
5.7.2 Deleting the configurations stored in the HUB by "LD" control panel.....	- 57 -
5.7.3 Adjusting the number of controllers connected to the HUB by "LD" control panel.....	- 58 -

5.7.4	Choosing the HUB port for transferring the configuration by “LD” control panel	- 58 -
5.7.5	Displaying the last error in HUB mode by “LD” control panel	- 59 -
5.7.6	Connecting 6 Controllers to the HUB	- 59 -
6	BLE Option	- 60 -
7	WiFi Option	- 60 -
8	TCP-Adapter	- 61 -
9	Status and failure modes indicated by the LED	- 61 -
9.1	Menu codes for control panels without height indication “LM”	- 62 -
9.2	Menu codes indicated by “LD” control panels	- 63 -
9.3	Failure codes indicated by the control panels	- 68 -
10	Sound signals	- 76 -
11	Directives and approvals	- 78 -
11.1	Directives followed	- 78 -
11.2	Approvals for European Controllers (230V versions)	- 78 -
11.3	Approvals for USA and Canada (115V versions)	- 78 -

1 The LTC table controller

Thank you for choosing our controller. The well-shaped controllers can be easily mounted below a tabletop or into a crossbar of a height adjustable table. A variety of control panels and control modes enable the user to find the optimum solution for many applications.

This instruction describes how to install and how to operate the controller.

1.1 Application

The LTC Controller series is designed and can be exclusively used to control motors for the height adjustment of tables. It has to be verified that the performance parameters of the motors and the connections of the motors fit the parameters and connections of the controller.



Attention: If used for other applications neither the function nor the safety can be ensured! Therefore, such use is not permitted, and warranty will be voided if used in applications outside the table height adjustment area.

1.2 For whom this document is prepared for

This document is an installation and operation instruction for the LTC series Laing Table Controllers and its accessories. The document is dedicated to manufacturers of height adjustable table frames and tables.

This document is not intended for end users!

1.3 Preconditions for the use of this document

This document describes the installation and operation of the controllers. It is assumed that the controller has already been configured for the application on which it is intended to be used. All parameters for the table the controller is intended to be mounted must be programmed before the actual installation.

Do not install the system before programming!

1.4 Safety instructions



Attention: There are no parts inside the controller which are serviceable or repairable by the user! Do not open the controller. If opened, the warranty will be void.

1.4.1 Indications for all Laing Table Controllers and all accessories (products)

Before any work is done with the products, read the instruction manual and follow the instructions!



Attention: The products may only be used as intended. Danger may occur if products are used in another way or in other applications than the intended ones.

- The installation may only be performed by qualified personnel with the required knowledge and the required capabilities!
- When making electrical connections, applicable electrical codes must be observed in respect to the way the connection is made, as well as who is authorized to perform such connection!
- Electrical installations can only be made by authorized personnel!
- Operation outside the specified operation limits is not allowed!
- Operation outside the specified environmental conditions is not allowed!

1.4.2 Indications for the operation of height adjustable tables



- Operation of a height adjustable table is only allowed after being instructed by a person familiar with the product or after thorough study of the instruction manual.
- Children are not allowed to play on the table.
- When operated, no persons are allowed on the tabletop
- **Danger of collision!** The table must be placed in a way that it can operate without colliding with any objects like drawers or windowsills!
- **Danger of injury by squeezing!** The table must be placed and operated in a way that no person can be squeezed between the tabletop or other parts of the table and other objects in the vicinity of the table.
- Children under the age of 8 and people with mental or physical disabilities are only allowed to operate the table if they have been sufficiently familiarized with the operation of the table and if it is certain, that they will not be overburdened with the operation of the table.
- Use of the table is only permitted in closed buildings where it can be ensured that no water or high humidity can get to the electrical parts.
- The controllers are manufactured and tested using the utmost care. Should there be a problem, please contact our service department.

1.5 Design of the table controllers

- Highly efficient switching power supply drives one, two, three or four motor channels (controllers for mains connection)
- The motor channels are controlled by a powerful processor

- The controller can be configured to a wide variety of applications by easy-to-use configuration software
- The aluminum housing provides superior heat dissipation which is why in most applications the cool down time is not determined by the controller but by the motors connected to the controller
- Optional integrated collision detection
- Status indication by LED or by control panels with height indication
- A bus connection is provided for the following uses
 - Connection of the control panels
 - Configuration of the controller by PC
 - Firmware update
 - Synchronization of up to six controllers
- An internal extension port is provided for the optional placement of a WiFi or BLE module. The BLE module enables the operation by wireless control panels

1.6 Specifications

380-Watt series

Type	LTC 302 EU	LTC 382 EU	LTC 383 EU	LTC 384 EU
Max. output power	300 W	380 W	380 W	380 W
Output voltage	24 V	24 V	24 V	24 V
Output current total	15 A	19 A	19 A	19 A
Motor channels	2	2	3	4
Max. current per channel	9 A	9 A	9 A	9 A
Synchronization	By HUB or LD	By HUB or LD	By HUB or LD	By HUB or LD

Type	LTC 302 US	LTC 382 US	LTC 383 US	LTC 384 US
Max. output power	300 W	380 W	380 W	380 W

Output voltage	24 V	24 V	24 V	24 V
Output current total	15 A	19 A	19 A	19 A
Motor channels	2	2	3	4
Max. current per channel	8 A	8 A	8 A	8 A
Synchronization	By HUB or LD	By HUB or LD	By HUB or LD	By HUB or LD

530-Watt series

Type	LTC 532 EU	LTC 533 EU	LTC 534 EU
Max. output power	530 W	530 W	530 W
Output voltage	36 V	36 V	36 V
Output current total	22 A	22 A	22 A
Motor channels	2	3	4
Max. current per channel	11 A	11 A	11 A
Synchronization	By HUB or LD	By HUB or LD	By HUB or LD

Type	LTC 532 US	LTC 533 US	LTC 534 US
Max. output power	530 W	530 W	530 W
Output voltage	42 V	42 V	42 V
Output current total	16 A	24 A	32 A

Motor channels	2	3	4
Max. current per channel	8 A	8 A	8 A
Synchronization	By HUB or LD	By HUB or LD	By HUB or LD

240-Watt series

Type	LTC 242 EU
Max. output power	240 W
Output voltage	24 V
Output current total	10 A
Motor channels	2
Max. current per channel	8 A
Synchronization	By HUB or LD

Type	LTC 242 US
Max. output power	240 W
Output voltage	24 V
Output current total	10 A
Motor channels	2
Max. current per channel	8 A

Synchronization	By HUB or LD
-----------------	--------------

1.6.1 Controller for mains connection LTC

380-Watt series

Type	LTC 302 EU	LTC 382 EU	LTC 383 EU	LTC 384 EU
Input voltage	220-240 V 50/60 Hz	220-240 V 50/60 Hz	220-240 V 50/60 Hz	220-240 V 50/60 Hz
Input current	2,9 A	3,5 A	3,5 A	3,5 A
Frequency	50/60 Hz	50/60 Hz	50/60 Hz	50/60 Hz
Standby power	50 mW	50 mW	50 mW	50 mW

Type	LTC 302 US	LTC 382 US	LTC 383 US	LTC 384 US
Input voltage	100-120 V 50/60 Hz	100-120 V 50/60 Hz	100-120 V 50/60 Hz	100-120 V 50/60 Hz
Input current	5,3 A	6,3 A	6,3 A	6,3 A
Frequency	50/60 Hz	50/60 Hz	50/60 Hz	50/60 Hz
Standby power	50 mW	50 mW	50 mW	50 mW

530-Watt series

Type	LTC 532 EU	LTC 533 EU	LTC 534 EU
------	------------	------------	------------

Input voltage	220-240 V 50/60 Hz	220-240 V 50/60 Hz	220-240 V 50/60 Hz
Input current	4,9 A	4,9 A	4,9 A
Frequency	50/60 Hz	50/60 Hz	50/60 Hz
Standby power	50 mW	50 mW	50 mW

Type	LTC 532 US	LTC 533 US	LTC 534 US
Input voltage	100-120 V 50/60 Hz	100-120 V 50/60 Hz	100-120 V 50/60 Hz
Input current	10 A	10 A	10 A
Frequency	50/60 Hz	50/60 Hz	50/60 Hz
Standby power	50 mW	50 mW	50 mW

240-Watt series

Type	LTC 242 EU
Input voltage	220-240 V 50/60 Hz
Input current	2,3 A
Frequency	50/60 Hz
Standby power	50 mW

Type	LTC 242 US
Input voltage	100-120 V 50/60 Hz

Input current	4,3 A
Frequency	50/60 Hz
Standby power	50 mW

1.6.2 Controller for DC-operation LTCD

Type	LTCD 302	LTCD 382	LTCD 383	LTCD 384
Input voltage	10V-36V	10V-36V	10V-36V	10V-36V
Input current	15 A	15 A	22 A	30 A
Frequency	DC	DC	DC	DC
Standby power 12V	80 mW	100 mW	100 mW	100 mW
Standby power 24V	180 mW	220 mW	220 mW	220 mW

1.6.3 Controller for battery-operation LTCB

Type	LTCB 302	LTCB 382	LTCB 383	LTCB 384
Battery voltage	32V	32 V	32V	32V
Input current	13 A	13 A	13 A	13 A
Frequency	DC	DC	DC	DC
Standby power battery and controller	5 mW	5 mW	5 mW	5 mW

1.7 Environmental conditions

The environmental conditions are valid for all controllers and accessories

Environmental temperature for storage and transport: min: -20°C to max: 60°C

min: -4°F to max: 140°F

Environmental temperature for operation:

min: 5°C to max: 45°C

min: 41°F to max: 113°F

Max. humidity for storage, transport and operation: 95% non-condensing

1.8 Dimensions controller for mains connection LTC

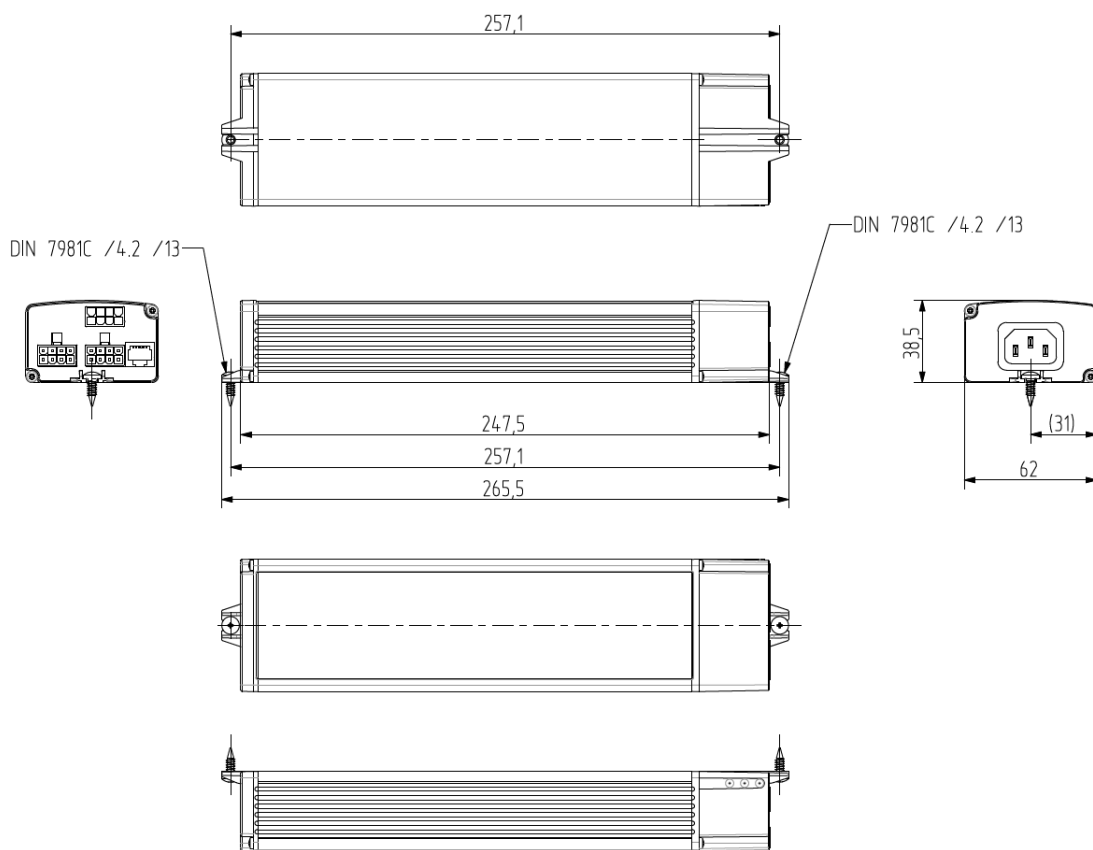

1.9 Dimensions controller for DC-operation LTCD

1.9.1 LTCD

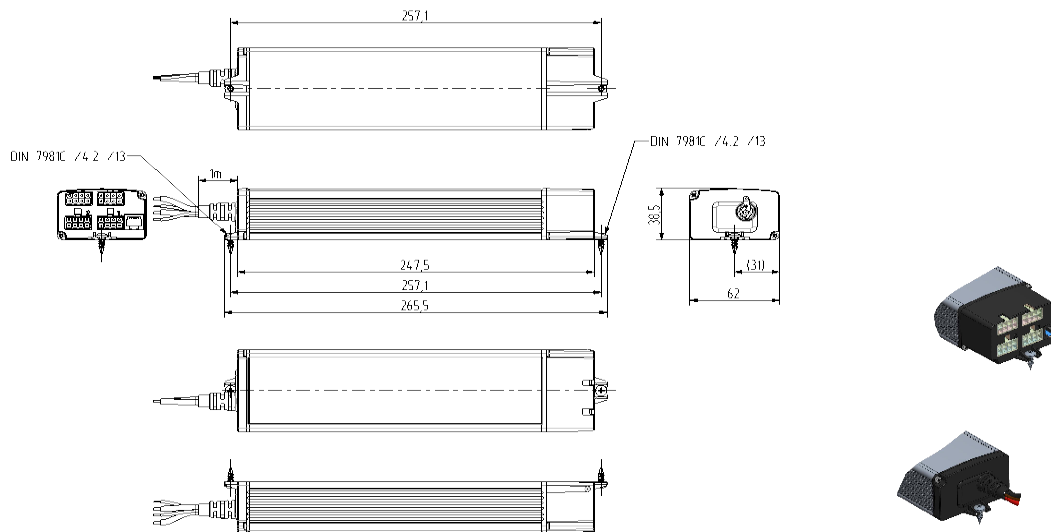

1.9.2 LTCD Rev. 2 (from 2025)

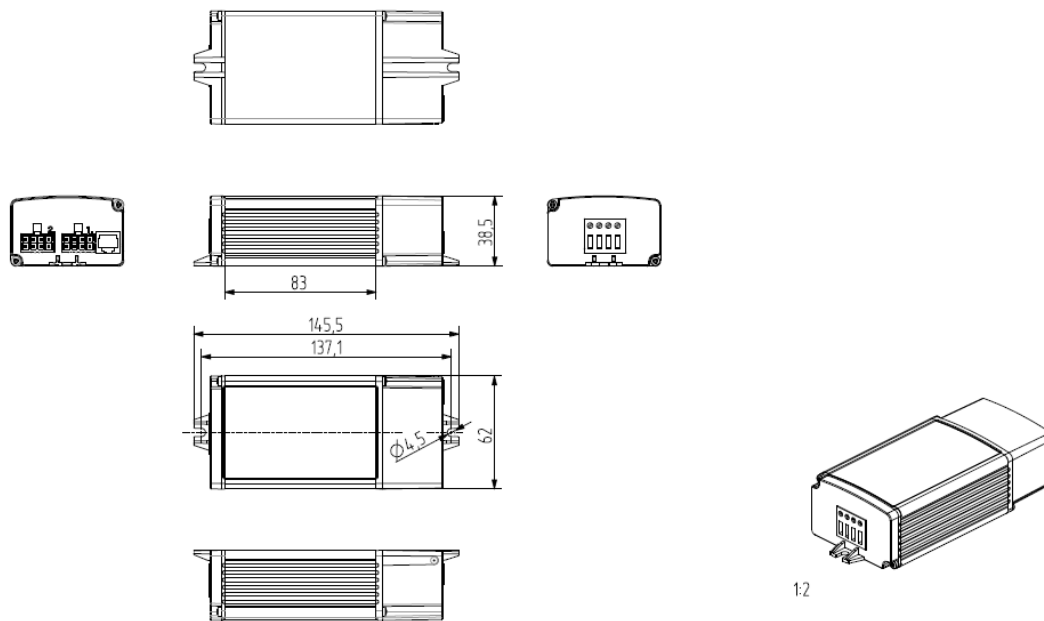

1.10 Dimensions controller for battery-operation LTCB

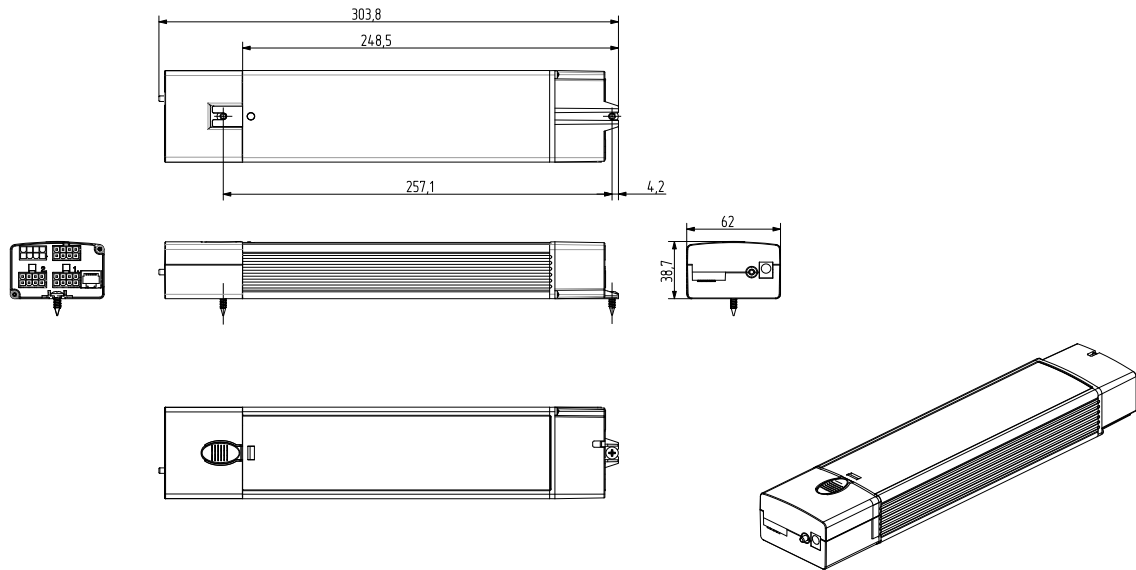

1.11 Options

The following options can be ordered with the controller

- WiFi module: the controller will be supplied with an integrated WiFi module. All table functions can be controlled through WiFi
- BLE module: the controller will be supplied with an integrated BLE module. All table functions can be controlled through BLE, this can be done for example by a smart phone app. This also is required for the wireless control panel.
- GyroSense/ GraviSense option: the controller will be supplied with an integrated collision detection sensor.

1.12 Delivery contents

The controller will be supplied in bulk packages; these contain the controller only. The power cable, motor cables and control panels will be supplied in separate bulk package boxes. Fixing screws are not provided.

2 Installation of the controllers

The controller will be attached to the bottom of the tabletop by two screws, one on each fixing point at the ends of the controller. A suitable fastener size is #8 wood screw. The length is determined by the thickness of the tabletop; however, it should be a minimum of ½ inch. When using other size screws, it is important,

that the shaft of the screw is not wider than the slot in the fixing point and that the head is not bigger in diameter than 3/8 inch. The torque is determined by the material of the tabletop; it is important that the fixing points at the endcap of the controller don't get deformed.

The controller can also be mounted on the cross bar; in this case the mounting can be done by M4 metric screws with a spring washer to secure the connection.

2.1 Battery controller LTCB

For mounting the battery controller, the battery must be removed from the controller. The controller can be screwed to the tabletop directly through hole A. It is mandatory that the screw head is not higher than 1/8 inch. Otherwise, the battery can't be inserted into the controller.

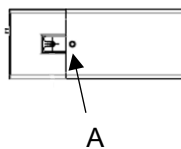

The device can be installed either horizontally or vertically. When installed vertically, the battery must be positioned at the top.

Important! When the controller with GyroSense or GraviSense option is used, the controller must be mounted directly to the bottom of the tabletop to ensure an optimal function of the collision detection.

2.2 Controller with GyroSense / GraviSense

The sensing element of the GyroSense and the GraviSense for the collision detection is contained in the controller itself. This is why the controller with the GyroSense or GraviSense option must be mounted directly to the bottom of the tabletop as otherwise the movement of the tabletop cannot be properly sensed.

The standard setting assumes that the controller will be mounted in parallel to the cross bar which connects the two legs of the table. Should the controller be mounted perpendicular to the cross bar, the configuration of the controller must be adapted to that. Without that, a reliable collision detection will not be possible.

For the successful function of the GyroSense and the GraviSense, it is very important that the table stands with all legs on the floor so that it cannot wobble. If the table can wobble the GyroSense or the GraviSense may react to the wobbling instead of a collision.

2.3 Installation of the control panels

2.3.1 Rectangular control panels

The square control panels will be mounted from the bottom to the edge of the tabletop in a way that the keys will be easily accessible. The cable must be attached to the bottom of the tabletop in a way that it does not put tension on the control panel or the controller but also does not hang loose.

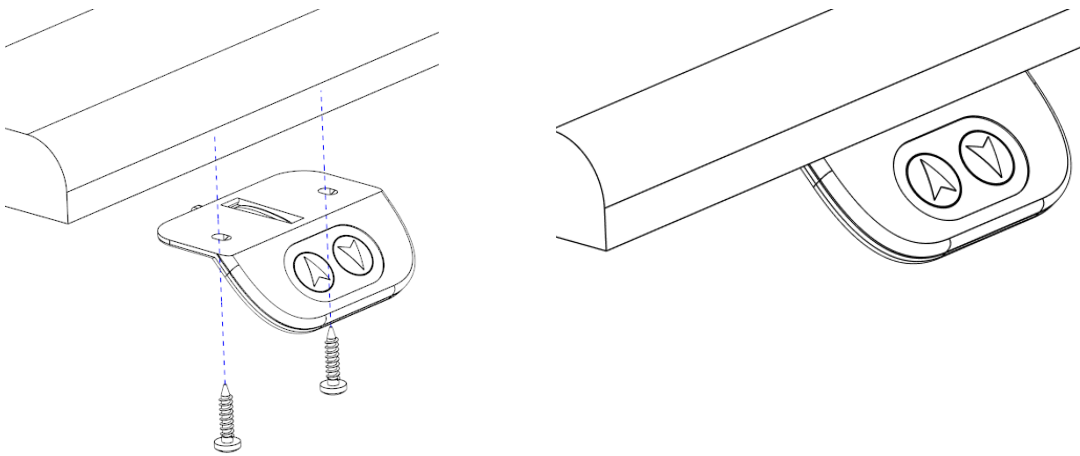

2.3.2 Oval control panels

For the installation of the oval control panels an appropriate pocket and a ½" hole must be machined into the tabletop. The cable will be put through the hole from the top, then the control panel will be pressed from the top into the pocket. **While inserting the control panel make sure the control panel will not be pressed too hard, if required the size of the pocket has to be adjusted.** The cable must be attached to the bottom of the tabletop in a way that it does not put tension on the control panel or the controller but also does not hang loose.

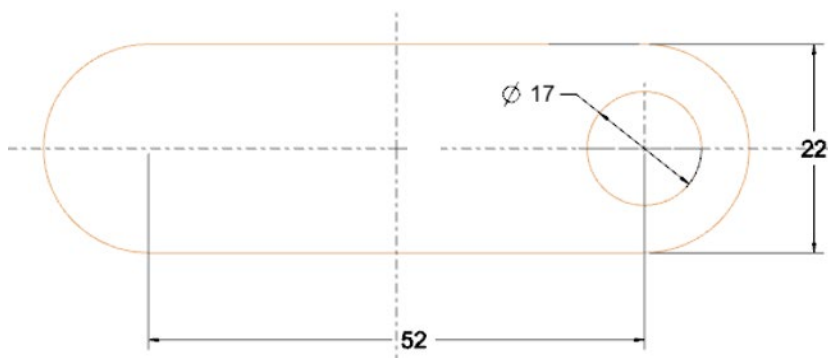

Cutout for control panels with two and four buttons IC series

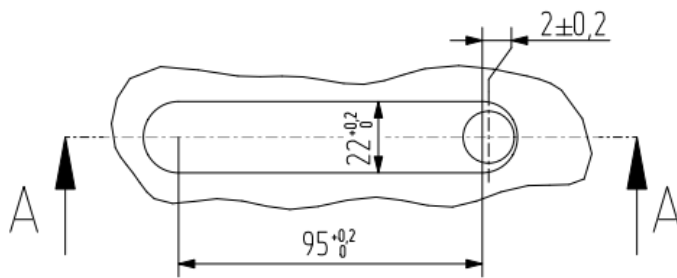

Cutout for control panels with six buttons IC series

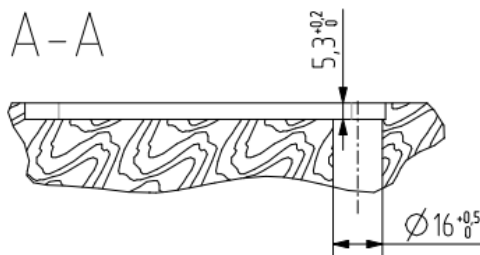

Cross section table cut-out

2.4 Electrical connection

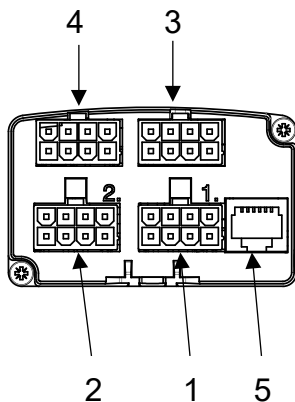

The picture shows the output connection side of the controller.

- 1 Motor 1
- 2 Motor 2
- 3 Motor 3 (LTC 383 and LTC 384)
- 4 Motor 4 (LTC 384 only)
- 5 Control panel and bus connection

2.4.1 Connectable Motors

The controllers are designed to be connected to motors with the following ratings. Besides the suitable rating, it is required that the motor connectors correspond to the pin assignment shown under “Pin assignment for motors” below.

Nominal voltage	24 V
Maximum current	8 A
Number of hall sensors (90°)	2
Hall sensor supply voltage	5 V
Maximum current hall sensors	50 mA

2.4.2 Pin assignment controller

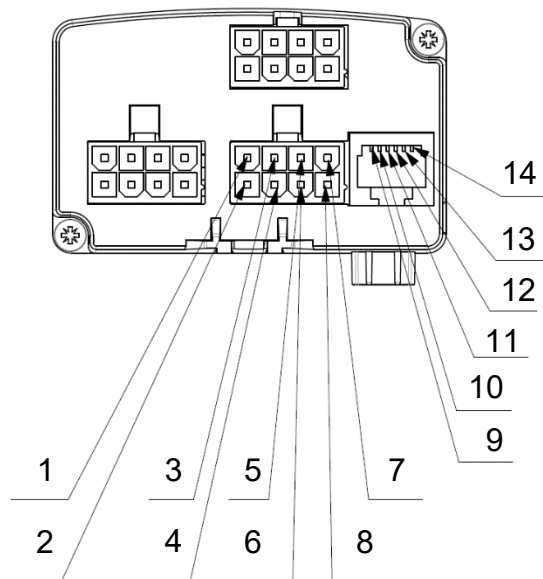

Pin assignment motor

1	Motor connection 1
2	Hall sensor 1
3	Ground
4	Hall sensor +5 V
5	Optional 2
6	Optional 1
7	Hall sensor 2

Pin assignment bus

9	+5V output
10	RS 485 A
11	RS 485 B
12	+5V input
13	Analog control panel
14	Ground

8 Motor connection

2.5 Connection of the motors

The motors must have an 8 pole Molex plug and must comply with the requirements described under “Connectable motors”

The motors may then be plugged into the controller connectors in the order shown on the controller cover. When plugged in, the snap-in pin will retain the plug. Make sure to press the snap-in pin when unplugging a motor to avoid damage to the plug or to the controller.

2.6 Connection of the control panels and other control options

2.6.1 Control panels with cable

The control panels with cable must be plugged into connector 5 of the controller. Make sure that the plug is locked by the snap-in. To unplug, the snap-in pin must be pressed, not doing so may result in plug or controller damage!

2.6.2 Connection of two control panels

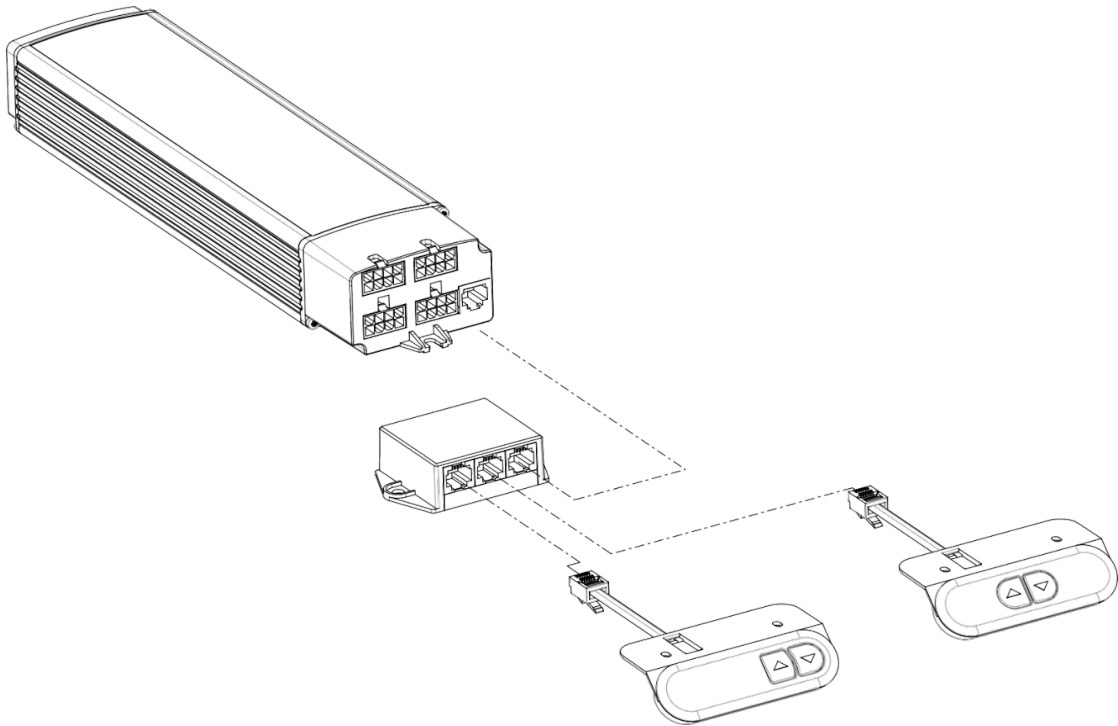

The controllers can be controlled by two control panels. To do so the Splitter-Adapter is required. The connections must be made as shown in the picture. The Splitter-Adapter is connected to the controller, a control panel with height indication is connected to the second port, a control panel without height indication to the third.



Attention! It is not possible to connect two control panels with height indication or two control panels without height indication to one controller. This will result in the malfunction of the controller. Should more control panels be required see next step.

2.6.3 Connection of up to 11 control panels

It is possible to control one controller by up to 11 control panels. To do so the HUB LH 6 is required. The controller will be connected to one port of the HUB, to the other ports of the HUB, control panels can be connected in any combination of control panels with height indication and without height indication. Where a controller or control panel with height indication is connected, a control panel without height indication can be added by using a Splitter-Adapter.

When more than one control panel is used, the control panel activated first is in control, pressing a button on another control panel while a control panel is still in

use, will stop the movement. This also applies when the movement is initiated by BLE or WiFi.

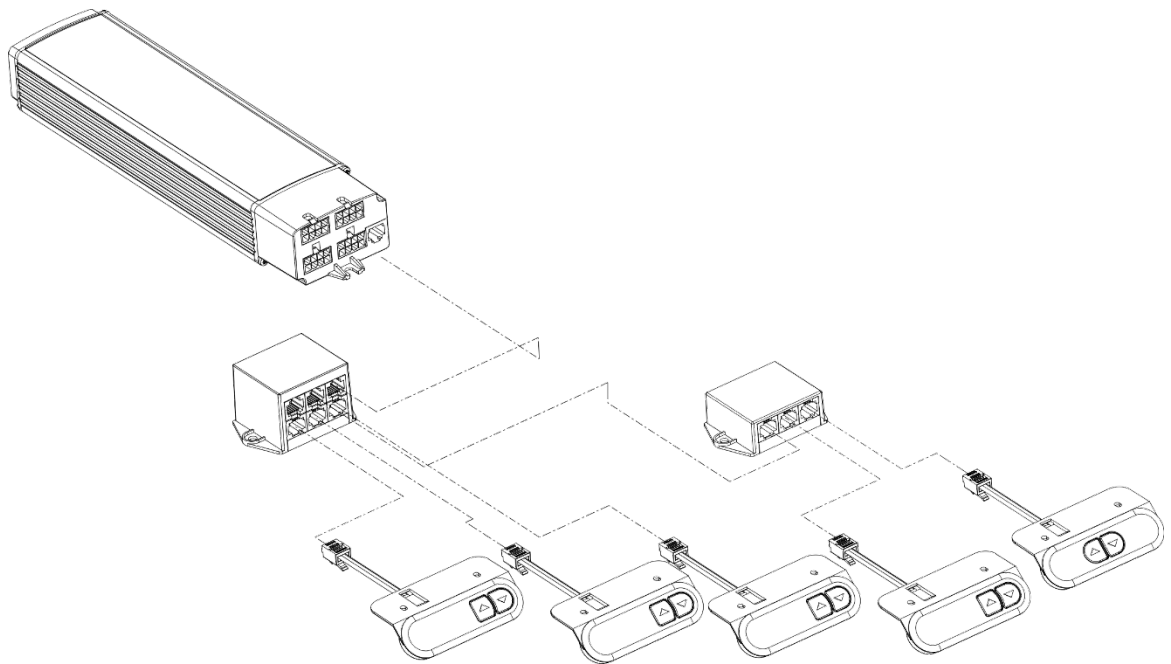

2.7 Wireless control panel LM4RW

2.7.1 Connection

The wireless keyboard LM4RW can be connected to any controller that is equipped with a BLE Module. Make sure the BLE module in the controller is activated through the Wizard or the LD control panel before using the keyboard.

In addition to the wireless control panel, other control panels can be connected to the controller.

2.7.2 Mounting the wireless control panel



Attention: It is mandatory that the keyboard will be mounted in a position from where the movement of the table can be observed while pressing! Mounting the keyboard outside the range of sight is not allowed!

The control panel LM4RW will be supplied with an adhesive tape on the bottom. Peel off the protective film and glue the keyboard to the desired place. The place should not be further away from the controller than about 5 feet. Where required the control panel can be fixed with a screw too.

2.7.3 Pairing the control panel and the controller

First the control panel must be paired to the controller. After plugging the controller in to the mains, the controller is ready for pairing for the first 15 seconds. If the controller is plugged in already, the mains cable must be unplugged until the LED in the controller goes off, so wait about 20 seconds until plugging it back in.

While the controller is ready for pairing, press the “up“ and “down“ keys on the control panel simultaneously, until you hear a sound from the motors connected to the controller. If the melody goes upwards, the keyboard is paired to the controller. Now the controller can be controlled by the keyboard.

If the keyboard has been paired to the controller before already, the pairing action will result in an unpairing of the keyboard. This is indicated by a descending melody given out by the motors. After being unpaired, the controller will not react to the keyboard commands anymore.

The pairing can also be started through the wizard. For this the pairing mode must be activated on the “basic“ page. By pressing the “up“ and “down“ key of the keyboard simultaneously within 15 seconds of activation of the controller the same effect as described above will occur.

Up to 15 keyboards can be paired with one controller, a keyboard can be paired with an unlimited number of controllers.

To connect another keyboard or to connect the keyboard to another controller, perform the described pairing procedure again with a different keyboard or a different controller.

When a keyboard is paired with more controllers, all controllers will start moving, once they get the command by the keyboard. However, while the controllers start and stop simultaneously, they will not be synchronized.

If more than one keyboard is paired with a controller, always the keyboard pressed first controls the controller. If another keyboard is pressed during the movement, the movement will stop.

Key functions (the key must be pressed and kept pressed)

Up Arrow: Table will move upwards

Down Arrow: Table will move downwards

“1“ Key: Table will move to memory position 1

“2“ Key: Table will move to memory position 2

2.7.4 Battery change

Once the controller will not react any more to the control panel the battery in the control panel has to be changed. To do so, a blade must be inserted carefully between the top cover and the surface the control panel is glued to, to lift off the top cover. Then the battery can be changed on the PCB. It must be made sure that the key design matches the printed designations on the PCB when the cover is put back on the device.

2.8 Mains connection LTC

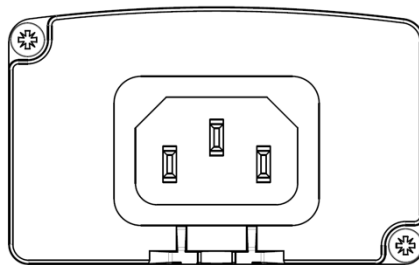

After the connection of the motors and the control panels the controller can be connected to the mains by plugging in the power supply cable to the connector shown on the picture. After that the cable can be plugged into the power socket.



Attention: Ensure that the power cable is positioned to provide strain relief at the plug, preventing the plug from being disconnected from the controller.

2.9 Connection LTCD

The controllers of the LTCD series are equipped with a 4-cored connection cable.

- Blue: ground
- Brown: 10 V-36 V plus
- Red: 5 V input (optional)
- Black: 5 V output (optional)

The power supply for the controller occurs through the blue and the brown core. If the controller is supplied with voltage through these cores, the connected motors are operated when requested through a control panel.



Attention! Do not supply reverse voltage to the controller as this will damage the controller! Therefore, make sure that blue is minus and brown is plus!

When the controller is powered by a power supply what provides 5 V control voltage and where the main power supply can be switched on by a 5 V signal, then the blue and brown cores have to be connected as described, in addition to that the 5 V control voltage from the power supply must be connected to the red core of the controller cable, the signal input of the power supply has to be connected to the black core of the controller cable. If then a button is pressed on the control panel, the controller will provide 5 V to the black core what then will start the main power supply what will provide the power to the brown core. This ensures minimizing power consumption, as the main power supply can stay on standby until a movement is required.

The LTCD Rev. 2 is equipped with terminal connections.

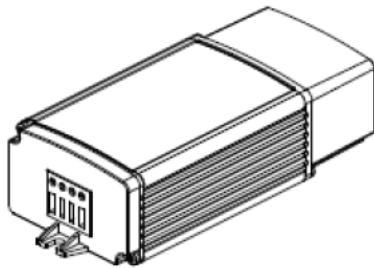

Connection from left to right:

10V-36V

Ground

5V input

5V output

2.10 Connection, battery change and charging of the LTCB

The battery controller doesn't have to be connected; it's only required to push the battery pack inside the controller and to make sure it snapped in.

By pushing the button on the battery pack, the charging status will be displayed. If all LEDs are lit, the battery is fully charged. If only the first LED is lighted, the

battery is almost discharged, if the first LED is blinking, the battery must be charged.

The battery can be charged inside or outside of the controller. Therefore, the battery charger must be plugged into the charging socket and connected to the mains. While charging the first LED is blinking until the charging status exceeds 25 %, then the first LED is lighted permanently and the second LED is blinking. The charging process is completed when all LEDs are lit permanently. Charging can also be done while operating the controller.

The charging time is about 6 hours; charging can be done between 41°F and 113°F battery cell temperature.

Whilst the motors are active, the LEDs which show the current charging status are lighted.

If the battery cells reached a temperature below 41°F or above 113°F, operating the controller isn't possible, until the cells reached the permitted temperature range again.

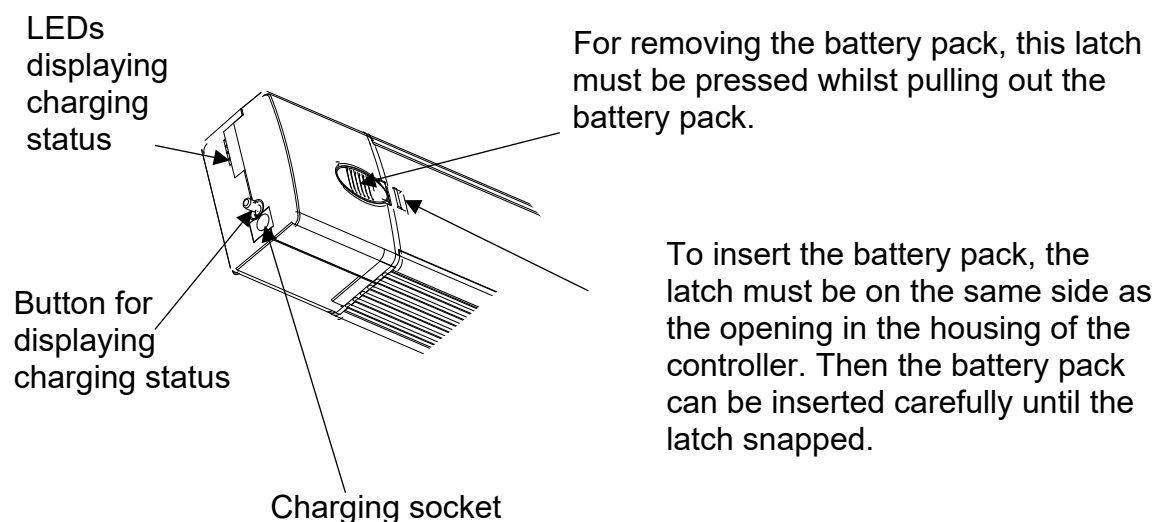

2.11 Preconditions for the start of operation of the controller



Before the start of operation make sure that the parameter set suitable for the table to be operated is loaded into the controller. If this is not the case, the table may make undesired movements, also required protection settings may not be activated! **Starting the controller with the wrong parameter set may result in injury to the operator and damage to both the table and the controller!**



Attention: When operated, the table must be free of obstacles and must be able to move over the whole movement range without hitting anything or injuring anyone!

3 Start of operation

After mounting the controller and the control panels, making all electrical connections and making sure that the right parameter set is loaded to the controller, the table can be put into service.

Upon power up, the table makes a reference run to acquire the reference position. To do so the “up” or “down” key must be pressed until the table reaches the reference position (normally the lowest point or the position of a limit switch) and further until the table elevates to the lowest programmed position (this may be about 20mm or 3/4” higher than the lowest position).

After the reference has been established, the table is ready for regular operation. By pushing the “up” or “down” key, the table can be moved between the upper and the lower positions defined in the parameter set in the controller specific for this table.

3.1 Current based collision detection

As a standard all controllers are equipped with a simple, current-based collision detection. This collision detection must be activated through the parameter set. To achieve a satisfactory functioning of this feature, parameters specific to the table must be defined and entered.

When activated the current based collision detection will stop the movement of the table as soon as the tabletop hits an obstacle. After the stop the tabletop will move in the opposite direction by the distance specified in the parameter set. After that the “up” or “down” key must be pressed again to move the table.



Attention: Please note that the sensitivity of the current based collision detection on downward movements is reduced drastically if the table is loaded with weight!

Should the performance of the current based collision detection not be satisfactory, the use of the GyroSense or the GraviSense collision detection system is recommended.

3.2 GyroSense based collision detection

The Laing GyroSense System provides collision detection between a table and an obstacle. To enable that, controllers ordered with this option are equipped with a very sensitive sensor that will sense even the smallest disturbance of the table’s upward or downward movement.

This system ensures a reliable detection of a collision, if the collision leads to a very small change in the position of the tabletop.

To sense such a change in position, the GyroSense equipped controller must be mounted to the tabletop. Placing the controller in the crossbar will not work!



Attention: Even if the system will sense reliably even very small, unusual movements of the table, it cannot be 100% insured that this will avoid injuries of the table users and people around the table as also the mechanic of the table and the environment of the table can cause such injuries! This is why no liability can be accepted for personal injury or any other damage! It is the user's sole responsibility to make sure that personal injury and any other damage is avoided throughout the operation of the table.

3.3 GraviSense based collision detection

As a third option for the collision detection the gravitation sensor can be used. This mode reacts to the change of the angle of the tabletop throughout travel.

For every axis it can be adjusted at which deviation from the starting angle a collision event is initiated. This option eliminates the danger that the table may tilt by more than the adjusted angle. If the angle is for example set to 2°, the movement will stop as soon as the absolute angle in reference to the center of earth varies by more than 2° throughout travel.

To sense such a change in position, the GraviSense equipped controller must be mounted to the tabletop. Placing the controller in the crossbar will not work!



Attention: Even if the system will sense reliably even very small, unusual movements of the table, it cannot be 100% insured that this will avoid injuries of the table users and people around the table as also the mechanic of the table and the environment of the table can cause such injuries! This is why no liability can be accepted for personal injury or any other damage! It is the user's sole responsibility to make sure that personal injury and any other damage is avoided throughout the operation of the table.

3.4 Adjusting the sensitivity level by the user

After using the table over a longer period, it is possible that the movement of the table becomes rough because of wear and/or dirt. This may result in an activation of the collision detection without any collision occurring. Therefore, it is possible for the user to change the sensitivity level of the collision detection by using the control panel menu.

This happens simultaneously for all three types of collision detection if they are activated and for all values set for the motors or axes.

By default, the sensitivity level is set to the highest sensitivity “2”.

For each type of collision detection there is a percentage set in the controller, by which the limit value of the sensitivity is being changed. When changing the sensitivity level from 2 to 3, each limit value is multiplied by the according percentage and added to the limit value, when switching from 3 to 4 it is added once again.

If the limit value for the Y-axis is adjusted for example to 40 and the percentage change is set to 50 %, then, when switching the sensitivity level from 2 to 3, 50 % of 40 are being added, so the limit value amounts to 60. When switching from 2 to 4, the limit value amounts to 80, the collision detection hence is only half as sensitive as with the default setting.

If configured in this way in the controller, sensitivity level 1 can be selected by the user, which results in all collision detections being deactivated.



Attention: In this case no collision detection is provided anymore.

Adjusting the sensitivity level is described in the menu description for “LM” and “LD” control panels.

3.5 Reference run

At first start up, when the table legs have an uneven height or if the wrong height is indicated, a reference run is required. For this the reference mode must be activated by pushing the “down” arrow 4 times.

When the reference mode is activated, all legs will move downwards with the defined reference speed, no matter if the “up” or “down” key is pressed. The movements are synchronized until the first leg reaches its reference position, after that the remaining legs will continue moving in the “current mode” until they reach their reference position. After that the travel will be set to “0”, that means that the control panel will show the height above the floor. Then the drives move upwards by the defined bottom margin.

The reference position can be acquired by:

- Hitting the lower stop of the drive
- Reaching a middle switch
- Reaching a limit switch at the lower end what disconnects the motor

The method by which the reference position is being acquired must be set in the Wizard.

If a power failure occurs or the mains plug is being pulled out while traveling, the controller will go to reference mode automatically.

If it isn't possible to perform a reference run downwards, a reference run can be set upwards. For this, it is required that the drive contains a limit switch or an upper stop at the top position, which can be driven against.

3.6 Determining the stroke by the reference run

When the stroke detection is activated in the Wizard, a reference run will not only establish the reference position but will also determine the stroke of the drive. To enable this, the drives must be equipped with a limit switch at bottom and at the top, or the drive must support that the bottom and top mechanical stop can be hit to enable the controller to determine the end position without limit switch. If this is the case, the feature can be activated in the Wizard in two ways. It is possible to activate it either in a way that the stroke is determined in every reference run or just once.

When the reference run is activated, then all drives will move downwards with the set reference speed, irrespective of whether the "up" or "down" arrow is pressed. The movements are synchronized until the first leg reaches its reference position, after that the remaining legs will continue moving in the current mode until they reach their reference position. After that, the travel will be set to "0", that means that the control panel will show the height above the floor.

Then the movement is reversed, the drives move upwards, until the first drive reaches its upper limit switch or hits the upper mechanical limit. Then all drives will stop, the actual height will be entered as travel and the drives will move downwards by the defined "top margin" or, in case this is lower than the "top margin" to the "user high".

After this process the stroke is set and isn't smaller than the "minimum pass" anymore, which is why it won't be detected again with the next reference run if the "one time" stroke detection is set. If a stroke detection is still desired, the automatic stroke detection can be requested by the menu 63 (menu 63 is only visible when the automatic stroke detection is activated).

3.7 Safety zone

For applications where there is risk of an accident when reaching the final part of the downward movement, e.g. when heavy tool shop tables are moved, a safety zone can be activated.

This function must be activated in the controller through the Wizard. There also a height must be entered where the safety zone starts, and a speed must be defined which is active while in the safety zone.

This function is only active when moving downwards!

If the controller is set accordingly, the downwards movement will stop when the set height is reached. Only after pressing the down button again will the movement continue with the speed set for the safety zone.

Alternatively, the controller can be set through the Wizard in a way that the movement continues with the speed set for the safety zone when the set height is reached. In this case the button doesn't have to be pushed again.

Through P35 the starting point of the safety zone can be set. For this, the drive must be driven to the desired height, then first P12, after that P35 must be called.

If the bottom user height is changed, the safety zone also moves for the set difference because the safety zone is always calculated based on the bottom user height.

3.8 Safety Input

The controller connector for motor 1 provides an input which can be configured as safety input. This function must be activated in the controller through the Wizard, also the voltage levels for normal operation and triggering of the safety function must be set. The connection is made through the safety adapter which provides an RJ45 connector where the safety devices can be connected.

If the safety device provides a voltage triggering the safety function, the controller reacts as if there were a collision. The movements will be stopped, and the drives will move in the opposite direction by the amount defined under "move back after collision".

The activation of the safety input can also be done automatically, when the safety adapter is plugged in. The automatic activation must be set in the Wizard, then the safety input function is activated and stays activated after the safety adapter was plugged in once to the motor 1 connector.

If the adapter is removed after that, the safety function will stay activated, that means an operation without safety adapter and attached safety equipment is not possible. By use of the "LD" control panels this function can be reset to auto detect mode, as described below in the menu Handling section.



Attention: The controller can only be used to protect equipment. It is not suitable to protect humans!

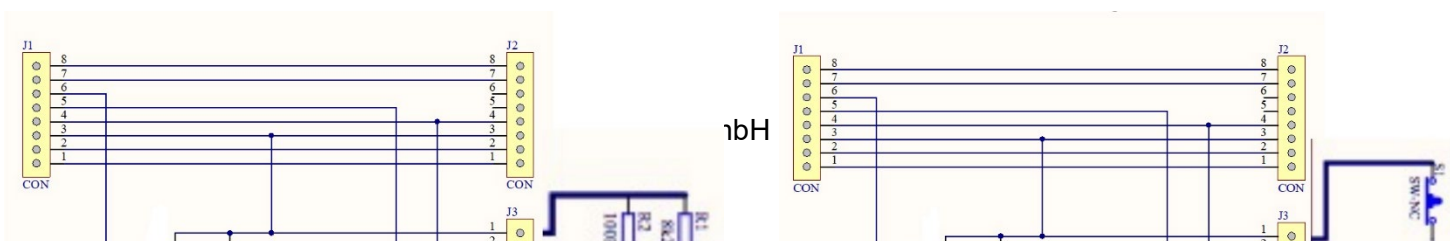

The picture shows the connection of a ribbon switch or sensing bumper to the safety input of the controller. The left side shows the content of the safety adapter, on the right side the part provided by the customer is shown in bolt lines. The 100 Ohm resistor represents the contact resistance of the ribbon switch.

The picture shows the connection of light curtains to the safety input of the controller. The left side shows the content of the safety adapter, on the right side the part provided by the customer is shown in bolt lines.

3.9 Automatic motor recognition

When the automatic motor recognition is activated in the controller through the Wizard the controller will check at every start up how many motors are connected by sensing where the Pin 3 to 6 of the motor connector is bridged.

If the number of detected motors equals the number set in the Controller, the drives will work.

If the number of detected motors is bigger than the number set in the Controller, the number of detected motors will be saved to the controller.



If the number of detected motors is smaller than the number set in the Controller, the drives will not work, the failure code F16 "Motor Presence Error" will be shown. In this case the number of motors in the controller must be changed by the Wizard or by using the "LD" control panels as described below in the menu handling section (see menu handling section chapter 9).

When automatic motor recognition is activated in the controller, it is recommended to set the number of motors to 1 when the controller is delivered to the customer. This can be done through the Wizard or by downloading the appropriate configuration file. Then, when put into service the controller will automatically set the number of motors to the number recognized.

The number of motors can be selected between one and the number of motor channels of the controller used.

4 Control through control panels

4.1 All Control panels

	Table will move upward	Keep the key pushed until the desired position is reached
	Table will move downward	Keep the key pushed until the desired position is reached

4.2 Control panels with memory keys

By using the memory keys the user can assign individual heights to these keys what then can be recalled when the memory key is pressed.

Which memory positions are stored in a new controller depends on the parameter set entered into the controller when configured by the table supplier.

	Recall previously stored memory positions	Keep the appropriate memory key pushed until the table stops at the stored position
---	---	---

4.3 Recall memory position with 2-Button control panel without height indication

Memory positions with a 2-button control panel without height indication can be recalled when the button mode is activated.

- To recall memory position 1, the “up” key must be pressed twice shortly one after another.

- To recall memory position 2, the “down” key must be pressed twice shortly one after another.

4.4 Control panels with height indication

Control panels with height indication show the actual height of the tabletop in centimeters or inches depending on the configuration.

4.5 Configuration of the controller through “LM” control panels (control panels without height indication)

In the Wizard it can be chosen whether the menu is accessible through the control panel or not. If not, the user is only able to set the memory position and to request a reference run.

4.5.1 Store memory positions with “LM” control panels

- Move the table to the desired height by use of the “up” or “down” keys
- press the memory key the position should be saved to 4 times quickly one after another
- Successful position saving will be confirmed by the number of sounds that correspond to the selected memory key number
- From now on height stored in the memory position can be adjusted by pressing and holding pressed the selected memory key until the table stops at the height stored



4.5.2 User height limit adjustment by “LM” control panels

4.5.2.1 Adjusting the upper and lower user height limits

Should window boards or drawer containers limit the possible movement of the table, then an upper and lower limit can be defined as follows:

- Move the tabletop by using the arrow keys to the maximum or minimum desired height
- Press the “up” arrow key 4 times quickly one after another
- Reaching the program mode will be confirmed by a sound
- Press the “down” arrow key shortly twice



- Reaching the limit adjustment menu will be confirmed by two sounds
- Then:
 - If the maximum height should be defined press the “up” key. The successful adjustment of the new upper limit will be confirmed by a sound
 - If the minimum height should be defined press the “down” key. The successful adjustment of the new lower limit will be confirmed by a sound



Attention: The top and lower positions must keep a minimum distance so that the table can still move after the new limits have been adjusted. This minimum distance is defined in the parameter set entered into the controller. Saving a new upper or lower limit is not possible if the minimum distance is not maintained. In this case, when pushing the appropriate arrow key to save the new limit the following sound can be heard, indicating that the new limit was not saved. In this case the distance between the upper and lower limit must be increased and the process must be repeated.



4.5.2.2 Deleting the user height limits

- Move the tabletop to the upper or lower limit by using the arrow keys (press the key until the table stops as the adjusted limit is reached)
- Press the “up” arrow key 4 times quickly one after another
- Reaching the program mode will be confirmed by a sound
- Press the “down” arrow key shortly twice
- Reaching the limit adjustment menu will be confirmed by two sounds
- Then:
 - If the tabletop is at the upper position and the adjustment for the upper position shall be deleted press the “up” arrow key.
 - If the tabletop is at the lower position and the adjustment for the lower position shall be deleted press the “down” arrow key.
- Successful deletion of the position will be confirmed by a sound

4.5.3 Minimum stroke

To prevent the user from setting the stroke by user height limit and stroke limit in a way that no movement is possible anymore, a minimum stroke is defined in the controller which can be adjusted in the Wizard.

Thereby, it's impossible to set upper and lower limits which fall below the minimum stroke.

If for example the upper user height limit shall be decreased in a way that the minimum stroke is undercut, the lower user height limit must be decreased as well, so the minimum stroke is ensured again.

4.5.4 Changing the sensitivity of the collision detection by “LM” control panels

Over time the movement of the table may change due to wear, dirt or change of the lubrication properties. This may result in a false activation of the collision detection. In this case the sensitivity of the collision detection can be adjusted as follows:



- Press the “up” arrow key 4 times quickly one after another
- Reaching the program mode will be confirmed by a sound
- Press the “down” arrow key 3 times quickly one after another
- Reaching the sensitivity menu will be confirmed by three sounds
- By use of the “down” arrow key the sensitivity of the collision detection can now be adjusted



- Press the “down” arrow key once (one sound): the collision detection will be deactivated
- Press the “down” arrow key two times (two sounds): the collision detection will be set to the factory setting, maximum sensitivity
- Press the “down” arrow key three times (three sounds): the collision detection will be set to medium sensitivity
- Press the “down” arrow key four times (four sounds): the collision detection will be set to low sensitivity

In the Wizard it can be selected whether deactivating the collision detection through the control panel is possible or not.

In the Wizard the following can be selected:

- Deactivating collision detection by sensitivity levels “on”: all four steps of the sensitivity levels are accessible through the control panel.
- Deactivating collision detection by sensitivity level “off”: only steps 2-4 of the sensitivity levels are accessible, deactivating the collision detection through the control panel isn’t possible

4.5.5 Initiating a reference run by “LM” control panels

Should the table for whatever reason show the wrong height or should one leg be higher than the other, a reference run must be initiated:



- Press the “down” arrow key 4 times quickly one after another

- Pressing either arrow key will now initiate the reference run. The key must be kept pressed until the table reaches its reference position and then moves back the set distance. Now the reference is recalibrated, the table should be leveled, and the height indication should be correct.

If a power failure occurs or the mains plug is being pulled out while traveling, the controller will go to reference mode automatically.

4.6 Configuration of the controller through “LD” control panels (with height indication)

In the Wizard can be chosen whether the menu is accessible through the control panel or not. If not, the user is only able to set the memory positions and to request a reference run.

4.6.1 Operation of “LD” control panels without memory keys

The LD control panels without memory keys cannot use memory one and memory two keys for the menu handling.



- Scrolling can only be done by the “up” arrow key
- Instead of the memory key 1, press the “down” arrow once
- Instead of the memory key 2, press the “down” arrow twice

4.6.2 Storing memory positions by “LD” control panels



- Move the tabletop by using the arrow keys to the desired height
- Press the memory key this height should be assigned to 4 times quickly one after another. Now the present position of the table is stored in the selected memory position



4.6.3 Activating button mode of the memory keys by “LD” control panels

In this menu item it can be selected if the memory position key must be kept pressed until the memory position is reached or if one key press is sufficient for the table to move to the stored height.



- Press the “up” arrow key 4 times quickly one after another
- Reaching the program mode will be confirmed by a sound





- The display will now show “P01”
- Press the “up” or “down” arrow key until the display shows “P05”
- Press the memory key “one” once shortly
- The display shows “0” or “1”
 - If it shows “0”, the memory key must be kept pressed until the desired height stored under the memory position is reached
 - If it shows “1”, the memory key must be pressed only once, then the table will move to the desired height stored under the memory position



- By using the arrow keys the indication can be toggled from “0” to “1” and from “1” to “0”. Once the right selection is made push the memory key “one” to confirm the selection, a sound will confirm that the setting is stored, the display will go back to normal operation and indicate the height
- When the selection is set to “1”, the table will move into the stored memory position until the position is reached. Make sure that such an “automatic” operation is allowed in the country the table is operated. If not, the selection “0”, where the movement can be stopped by releasing the key has to be selected
- When the selection “1” is made, the “automatic” movement can be stopped at any time by pressing any key on any control panel connected to the controller

In the Wizard in addition to the values “0” for button mode deactivated and “1” for button mode activated, it is also possible to select “2”. When selected, the button mode through the control panel is not possible, and the menu will not be visible.

4.6.4 User height limit adjustment by “LD” control panels

4.6.4.1 Adjusting the upper and lower limit

Should, for example, windowsills or drawers limit the possible movement of the table, an upper and lower limit can be defined as follows:



- Move the tabletop by using the arrow keys to the minimum or maximum desired height
- Press the “up” arrow key 4 times quickly one after another
- Reaching the program mode will be confirmed by a sound
- The display will now show “P01”
- Press the “up” or “down” arrow key until the display shows:
 - “P06” for adjustment of the lower height limit, the table must be at the minimum position
 - “P07” for adjustment of the upper height limit, the table must be at the maximum position



- Press the memory key “one” shortly to store the selected limit, the successful storage of the user position will be confirmed by the sound displayed



Attention: The top and lower positions must keep a minimum distance so that the table can still move after the new limits have been adjusted. This minimum distance is defined in the parameter set entered into the controller. Saving a new upper or lower limit is not possible if the minimum distance is not maintained. In this case, when pushing the appropriate arrow key to save the new limit the following sound can be heard, indicating that the new limit was not saved. In this case the distance between the upper and lower limit must be increased and the process must be repeated.



4.6.4.2 Deleting the user height limits



- Move the tabletop by use of the arrow keys to the minimum or maximum height (Keep the “up” or the “down” key pressed until the table stops moving)
- Press the “up” arrow key 4 times quickly one after another
- Reaching the program mode will be confirmed by a sound
- The display will now show “P01”
- Press the “up” or “down” arrow key until the display shows
 - “P06” for deletion of the lower height limit select, the table must be at the lowest position
 - “P07” for deletion of the upper height limit select, the table must be at the highest position



- Press the memory key “one” shortly to confirm the deletion, the successful deletion will be confirmed by a sound

4.6.5 Stroke limitation adjustment by “LD” control panels

4.6.5.1 Adjusting the stroke upper and lower limits

In some cases, the table may be built in a way that the maximum travel of the drive is limited by some additions to the table like facings. In this case a stroke upper and lower limit can be adjusted what limits the stroke of the drives. The user height then can only be adjusted within the adjusted stroke range.



Attention: Before the stroke limits are adjusted, the user height limits must be deleted when the stroke limits reach into the user height limit range! As the controller will be supplied with set limits, changes can only be made when the present value is deleted as described below, after that a new limit can be set.



- Move the tabletop by using the arrow keys to the minimum or maximum desired height
- Press the “up” arrow key 4 times quickly one after another
- Reaching the program mode will be confirmed by a sound
- The display will now show “P01”
- Press the “up” or “down” arrow key until the display shows “P12”



- Press the memory key “one” shortly to enter the menu.
- The display now will show “P30”
- Press the “up” or “down” arrow key until the display shows
 - “P31” for adjustment of the upper height limit, the table must be at the maximum position
 - “P32” for adjustment of the lower height limit, the table must be at the minimum position
- Press the memory key “one” shortly to store the selected limit, the successful storage of the user position will be confirmed by the sound displayed



Attention: The top and lower limits must keep a minimum distance so that the table can still move after the new limits have been adjusted. This minimum distance is defined in the parameter set entered into the controller. Saving a new upper or lower limit is not possible if the minimum distance is not maintained. In this case, when pushing the appropriate arrow key to save the new limit the following sound can be heard, indicating that the new limit was not saved. In this case the distance between the upper and lower limit must be increased and the process must be repeated.



4.6.5.2 Deleting stroke limits

Make sure, no user height limit is defined. If a user height limit is defined, see “delete user height limits” and delete the limits set before you proceed!



- Move the tabletop by use of the arrow keys to the minimum or maximum height (keep the “up” or the “down” key pressed until the table stops moving)
- Press the “up” arrow key 4 times quickly one after another
- Reaching the program mode will be confirmed by a sound
- The display will now show “P01”



- Press the “up” or “down” arrow key until the display shows “P12”
- Press the memory key “one” shortly to enter the menu.
- The display now will show “P30”
- Press the “up” or “down” arrow key until the display shows
 - “P31” for the deletion of the upper stroke limit, the table must be at the highest position
 - “P32” for the deletion of the lower stroke limit, the table must be at the lowest position



- Press the memory key “one” shortly to confirm the deletion



- The sound shown will confirm the deletion

4.6.6 Minimum stroke









To prevent the user from setting the stroke by user height limit and stroke limit in a way that no movement is possible anymore, a minimum stroke is defined in the controller which can be adjusted in the Wizard.

Thereby, it's impossible to set upper and lower limits which fall below the minimum stroke.

If for example the upper user height limit shall be decreased in a way that the minimum stroke is undercut, the lower user height limit must be decreased as well, so the minimum stroke is ensured again.

4.6.7 Changing the sensitivity of the collision detection by "LD" control panels

Over time the movement of the table may change due to wear or change of the lubrication properties. This may result in a false activation of the collision detection. In this case, the sensitivity of the collision detection can be adjusted as follows:

-  • Press the "up" arrow key 4 times quickly one after another
-  • Reaching the program mode will be confirmed by a sound
-  • The display will now show "P01"
-  • Press the "up" or "down" arrow key until the display shows "P08"
-  • Press the memory key "one" shortly to enter the setting mode
-  • The display now will show the actual sensitivity level
-  • Press the "up" or "down" arrow key to select the desired sensitivity of the collision detection
 - 1: The collision detection will be deactivated
 - 2: Default setting, highest sensitivity
 - 3: Medium sensitivity
 - 4: Lowest sensitivity
-  • Press the "memory one" key shortly to confirm the selection

In the Wizard it can be selected whether deactivating the collision detection through the control panel is possible or not.

In the Wizard the following can be selected:

- Deactivating collision detection by sensitivity levels "on": all four steps of the sensitivity levels are accessible through the control panel.
- Deactivating collision detection by sensitivity level "off": only steps 2-4 of the sensitivity levels are accessible, deactivating the collision detection through the control panel isn't possible

4.6.8 Initiating a reference run by “LD” control panels

Should the table out of any reason show the wrong height or one leg is higher than the other a reference run must be initiated by the following action



- Press the “down” arrow key 4 times quickly one after another
- Now the controller is in reference mode, the display now shows “---“
- Now either arrow key must be kept pressed until, the table reaches its reference position and then moves back to the lower position. If the reference is established the display will show the actual height. Now the reference is recalibrated, the table is leveled, and the height indication is correct.

If a power failure occurs or the mains plug is being pulled out while traveling, the controller will go to reference mode automatically.

4.6.9 Adjusting direction of the reference run

If a reference run downwards isn’t possible, an upwards reference run can be set. Therefore, it is mandatory that the drive has a limit switch, or a limit stop at the top end which can be driven against.



- Press the “up” arrow key 4 times quickly one after another
- Reaching the program mode will be confirmed by a sound
- The display will now show “P01”
- Press the “up” or “down” arrow key until the display shows “P14”
- Press the memory key “one” shortly to select the menu
- The display will now show “P60”
- Press the “up” or “down” arrow key until the display shows “P62”
- Press the memory key “one” shortly to enter the setting mode
- Press the “up” or “down” arrow key to select the desired setting
 - “0”: reference run downwards
 - “1”: reference run upwards
- Press the memory key “one” shortly to confirm the selection

4.6.10 Changing height indication from centimeter to inch by “LD” control panels

The height can be indicated in centimeter or inch. The factory setting depends on the parameter set loaded into the controller.







- Press the “up” arrow key 4 times quickly one after another

- Reaching the program mode will be confirmed by a sound
- The display will now show “P01”
-  • Press the “up” or “down” arrow key until the display shows “P10”
- Press the memory key “one” shortly to enter the setting mode
-  • The display now shows the actual setting
 - 0: Metric, indication in centimeter
 - 1: Imperial, indication in inch
-  • Press the “up” or “down” arrow key to select the desired setting
- Press the memory key “one” shortly to confirm the selection



4.6.11 Entering the info menu by “LD” control panel

For service purposes certain values and settings can be indicated in the display. The service menu can be entered as follows:

-  • Press the “up” arrow key 4 times quickly one after another
- Reaching the program mode will be confirmed by a sound
-  • The display will now show “P01”
- Press the “up” or “down” arrow key until the display shows “P11”
-  • Press the memory key “one” shortly to enter the menu
- The display now will show “P50”
-  • Press the “up” or “down” arrow key to select the desired menu item
- Once the desired menu item is reached press the memory key “one” shortly, now the value for the selected item will be shown
-  • To leave the menu item shortly press the memory key “two”
- Menu items:
 - P50: Charging state of the battery in percentage (LTCB)
 - P51: Temperature of the battery (LTCB)
 - P52: The last three figures of the vendor product ID
 - P53: Controller voltage (230 V, 115 V, 36 V, 32 V (battery))

4.6.12 Shifting the height indication by “LD” control panels

The indicated height shows the height from the floor to the tabletop. On some occasions when the table or drive is elevated or lowered it might be desired to shift the indicated height. To shift the indicated height, the lowest position of the table from the ground needs to be measured. Then proceed as follows:

-  • Press the “up” arrow key 4 times quickly one after another
- Reaching the program mode will be confirmed by a sound
- The display will now show “P01”
-  • Press the “up” or “down” arrow key until the display shows “P12”
- Press the memory key “one” shortly to enter the menu.



- The display now will show “P30”
- Press the “up” or “down” arrow key until the display shows “P33”
- Press the memory key “one” shortly to enter the setting mode
- Press the “up” or “down” arrow key to shift the indicated height until the measured value of the lowest table position is shown on the display
- Press the memory key “one” shortly to confirm the selection, now the accurate current height is shown.
- To leave the menu item press the memory key “two”

4.6.13 Defining the rounding for height indication by “LD” control panels

In this menu it can be defined how the height values indicated in the display will be rounded. For example, instead of indicating 50,1 or 48,8 the display will show 50. The rounding works the same way for centimeters and for inches.



- Press the “up” arrow key 4 times quickly one after another
- Reaching the program mode will be confirmed by a sound
- The display will now show “P01”



- Press the “up” or “down” arrow key until the display shows “P12”
- Press the memory key “one” shortly to enter the menu
- The display now will show “P30”
- Press the “up” or “down” arrow key until the display shows “P34”
- Press the memory key “one” shortly to enter the setting mode
- The display will now show the currently set value
- By pressing the “up” or “down” arrow key the desired setting can be selected:
 - “0” the display will show the first decimal
 - “1” the display will show only ,0 or ,5 as decimal
 - “2” the display will show only ,0 as decimal



- Press the memory key “one” shortly to confirm the selection
- To leave the menu item press the memory key “two”

4.6.14 Resetting user settings by “LD” control panel

This menu allows to reset all user settings to the values set when the controller was supplied to the customer. The following values will be reset:

- Memory position 1 to 4
- Upper user limit
- Lower user limit
- Button mode
- Collision detection
- Unit used in the display

- Indicated height
- Precision of the indication in the display



- Press the “up” arrow key 4 times quickly one after another
- Reaching the program mode will be confirmed by a sound



- The display will now show “P01”
- Press the “up” or “down” arrow key until the display shows “P12”



- Press the memory key “one” shortly to enter the menu
- The display now will show “P30”



- Pressing the memory key “one” shortly will reset the user settings
- To leave the menu item press the memory key “two”

4.6.15 Activating the BLE module

In this menu the BLE module in the controller can be activated or deactivated.



- Press the “up” arrow key 4 times quickly one after another
- Reaching the program mode will be confirmed by a sound
- The display will now show “P01”



- Press the “up” or “down” arrow key until the display shows “P13”
- Press the memory key “one” shortly to enter the menu
- The display now will show “P40”
- Press the memory key “one” shortly to enter the setting mode
- The display will now show the currently set value
- By pressing the “up” or “down” arrow key the desired setting can be selected:



- “0” BLE deactivated
- “1” BLE activated
- Press the memory key “one” shortly to confirm the selection
- To leave the menu item press the memory key “two”

4.6.16 Resetting the controller’s name

Through the Wizard or through the app the controller can be given a name which will be indicated in the app. This menu item will delete the selected name and reset it to the serial number.



- Press the “up” arrow key 4 times quickly one after another
- Reaching the program mode will be confirmed by a sound
- The display will now show “P01”



- Press the “up” or “down” arrow key until the display shows “P13”
- Press the memory key “one” shortly to enter the menu



- The display now will show “P40”
- Press the “up” or “down” arrow key until the display shows “P41”
- Press the memory key “one” shortly to delete the name
- The name is now reset to the serial number
- To leave the menu item press the memory key “two”

4.6.17 Activating the pairing mode

To connect a wireless control panel to the controller it has to be paired. To do this the controller must be put into pairing mode. This can be done in two ways:

1. After the controller is connected to the mains, it will be in pairing mode for 15 seconds. If the controller is plugged in already, unplug it for about 30 seconds. Then plug it back in, after that the controller is in pairing mode for 15 seconds. Within this time the keyboard can be paired to the controller
2. Call this menu



- Press the “up” arrow key 4 times quickly one after another
- Reaching the program mode will be confirmed by a sound
- The display will now show “P01”



- Press the “up” or “down” arrow key until the display shows “P13”
- Press the memory key “one” shortly to enter the menu
- The display now will show “P40”
- Press the “up” or “down” arrow key until the display shows “P42”
- Press the memory key “one” shortly to enter the pairing mode
- The controller will now be in pairing mode for 15 seconds, throughout this time the controller can be paired with a wireless control panel

4.6.18 Deleting connections to wireless control panels

This menu item will delete all paired wireless control panels in the controller.

To control the controller by a wireless control panel after this process, it has to be paired again first.



- Press the “up” arrow key 4 times quickly one after another
- Reaching the program mode will be confirmed by a sound
- The display will now show “P01”
- Press the “up” or “down” arrow key until the display shows “P13”
- Press the memory key “one” shortly to enter the menu
- The display now will show “P40”
- Press the “up” or “down” arrow key until the display shows “P43”

- Press the memory key “one” shortly to delete the connections
- Now all wireless control panel connections in the controller are deleted
- To leave the menu item press the memory key “two”

4.6.19 Resetting the private mode for the app

Through the App it is possible to activate the private mode in the controller. In this mode only the smart phone which activated the private mode can communicate with the controller.

By this menu item the private mode can be reset, after that the controller is accessible through all smart phones again.



- Press the “up” arrow key 4 times quickly one after another
- Reaching the program mode will be confirmed by a sound
- The display will now show “P01”



- Press the “up” or “down” arrow key until the display shows “P13”
- Press the memory key “one” shortly to enter the menu
- The display now will show “P40”
- Press the “up” or “down” arrow key until the display shows “P44”
- Press the memory key “one” shortly to reset the private mode
- Now the controller is accessible from all smart phones again

4.6.20 Entering the option menu by “LD” control panel



- Press the “up” arrow key 4 times quickly one after another
- Reaching the program mode will be confirmed by a sound
- The display will now show “P01”



- Press the “up” or “down” arrow key until the display shows “P13”
- Press the memory key “one” shortly to enter the menu
- The display will now show “P40”
- Press the “up” or “down” arrow key to select the desired menu
- When the desired menu is shown, press the memory key “one” to enter the menu
- To leave the menu item press the memory key “two”

The following settings can be set in the option menu.

- Enable or disable the BLE module
Select “P40”, select “1” to enable BLE, “0” to disable BLE, press the memory key “one” to confirm the selection

- Resetting the controller name to the serial number
Select “P41”, press “1” to reset the controller name shown in the app
- Activating the pairing mode for wireless control panels
Select “P42”, press “1” to activate the pairing mode for connecting wireless control panels
- Deleting connections to wireless control panels
Select “P43”, press “1” to delete all paired wireless control panels
- Resetting the private mode
Select “P44”, press “1” to reset the private mode
- Enable or disable WiFi
Select “P46”, select “1” to enable WiFi, “0” to disable WiFi, press the memory key “one” to confirm the selection

4.6.21 Resetting the number of connected motors

The controller can be configured in a way to automatically recognize the number of connected motors. The controller saves the recognized number as the actual number of drives connected. When a motor is added, the number will increase automatically.

When the number of motors is reduced, due to safety reasons the controller will not start the motors as someone might have forgotten to plug in a motor.

So, when the number of connected motors is reduced, the number must be reduced in the controller through the Wizard or through this menu item to the actual number or a smaller number. Then the controller can be operated again.



- Press the “up” arrow key 4 times quickly one after another
- Reaching the program mode will be confirmed by a sound
- The display will now show “P01”
- Press the “up” or “down” arrow key until the display shows “P14”



- Press the memory key “one” shortly to enter the menu
- The display now will show “P60”
- Press the memory key “one” shortly to enter this menu
- The display will now show the set number of motors so a number between 1 and the maximum number of motors the controller can handle
- By pressing the “up” or “down” arrow key the number of motors can be adjusted. If the automatic motor recognition is activated the number can be set to one, with the next movement the controller will recognize the actual number and save it. If the automatic motor recognition is not activated, the motor number must be set to the actual number.

- By pressing the memory key “one” the selected value will be saved

4.6.22 Resetting the Safety Adapter

The controller can be configured to activate the safety input function automatically, when the safety adapter is plugged into the Motor 1 connection. Thereafter the controller will only start the motors when the safety adapter and the safety devices are connected.

If the controller should operate without safety adapter after that, the safety input function must be deactivated through the Wizard or this menu item. However, for safety reasons automatic recognition will stay active.



- Press the “up” arrow key 4 times quickly one after another
- Reaching the program mode will be confirmed by a sound
- The display will now show “P01”



- Press the “up” or “down” arrow key until the display shows “P14”
- Press the memory key “one” shortly to enter the menu
- The display will now show “P60”
- Press the “up” or “down” arrow key until the display shows “P61”
- Press the memory key “one” shortly to enter the menu item
- The display will now show the currently set value
- By pressing the “up” or “down” arrow key the desired setting can be selected:



- “1” Safety adapter active, operation is only possible when safety adapter and safety devices are connected
- “2” Automatic recognition of safety adapter active, operation possible without safety adapter
- Press the memory key “one” shortly to confirm the selection
- To leave the menu item press the memory key “two”

4.6.23 Setting the starting point for the safety zone

For applications where there is risk of an accident when reaching the final part of the downward movement, e.g. when heavy tool shop tables are moved, a safety zone can be activated.

This function must be activated in the controller through the Wizard. There also a height must be entered where the safety zone starts, and a speed must be defined which is active while in the safety zone. This function is only active when moving downwards. In the Wizard can be set whether the downwards movement will stop when the set height is reached until the “down” button is pressed again

or if the movement continues without stop with the speed set for the safety zone when the set height is reached.

The starting point for the safety zone can be set as follows:

for safety reasons the automatic recognition will stay active.



- Drive the table to the desired height
- Press the “up” arrow key 4 times quickly one after another
- Reaching the program mode will be confirmed by a sound
- The display will now show “P01”



- Press the “up” or “down” arrow key until the display shows “P12”
- Press the memory key “one” shortly to enter the menu
- The display will now show “P30”
- Press the “up” or “down” arrow key until the display shows “P35”
- Press the memory key “one” shortly to set the starting point for the safety zone
- To leave the menu item press the memory key “two”
- If the bottom user height is changed, the safety zone also moves for the set difference because the safety zone is always calculated based on the bottom user height

4.6.24 Displaying the last error by “LD” control panel

If the control panel displays an error, it is possible to check through the menu on which drive the error occurred.

- Press the “up” arrow key 4 times quickly one after another
- The display will now show “P01”
- Press the “up” or “down” arrow key until the display shows “P15”
- Press the memory key “one” to select “P76”
- Press the memory key “one” shortly to display the 3-figured error code.
The first figure shows which drive is affected, the second and third figure shows the error
- Errors which aren’t drive-specific, like for example “power supply overload” are displayed with 2 figures only

4.7.25 Synchronization of 2 controllers by LD control panel

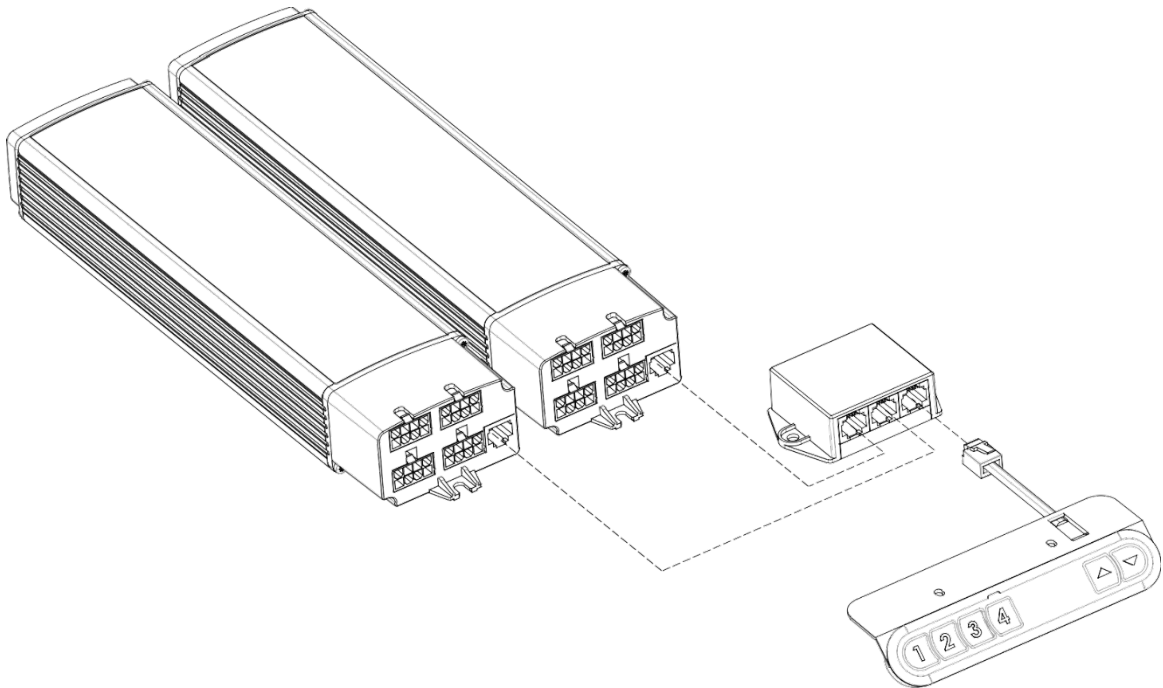

All control panels with height indication (LD series) can synchronize 2 controllers. The controllers must be configured as single controllers. The controllers and the control panel will be connected by the Sync-Adapter whereby care has to be taken, so that the control panel will be connected to the designated input. The movement can also be initiated by BLE- or WiFi-module installed in one or both controllers.

Attention! For this function the connected controllers must have the same firmware version! If this is not the case Error F23 will be shown.

The electronics in the Sync-Adapter will now configure the HUB mode in the controllers.

Now, all drives connected to the two controllers will be synchronized.

If only one controller is connected to the Sync Adapter, no operation is possible. When disconnected from the Sync-Adapter, the controllers automatically will go back to normal mode after a reset is made by unplugging the controllers for a few seconds.

4.6.25.1 Displaying the last error when synchronizing 2 controllers by “LD” control panel

If the control panel displays an error, it is possible to check through the menu on which drive the error occurs when 2 controllers are synchronized through the Sync Adapter.

- Press the “up” arrow key 4 times quickly one after another
- The display will now show “P01”
- Press the “up” or “down” arrow key until the display shows “P15”
- Press the memory key “one” to select “P76”
- Depending on which port of the Sync-Y-Adapter is affected by the error, 71 (port 1) or 72 (port 2) will be shown
- Press the memory key “2”, then press the “up” or “down” arrow key until the display shows the menu which was shown in P76. When e.g. “72” was shown, the menu “P72” must be selected
- Press the memory key “one” shortly to display the 3-figured error code. The first figure shows which drive is affected (motor output 1-4), the second and third figures show the error
- Errors which aren’t drive-specific, like for example “power supply overload” are displayed with 2 figures only

5 Synchronization of up to 6 controllers by HUB

By use of the HUB LH 6 up to 6 controllers can be synchronized allowing them to move up to 24 legs synchronously. Every connected keyboard as well as WiFi- and BLE-modules in the connected controllers can be used to move the connected drives.

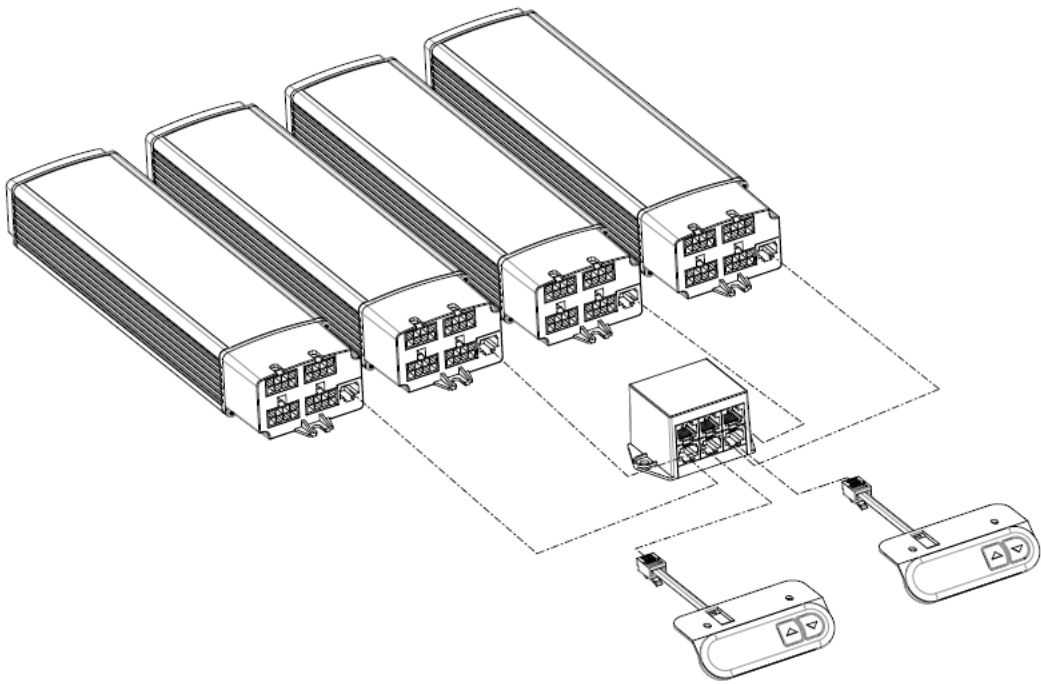

5.1 Port Designation

5.1.1 HUB LH-06

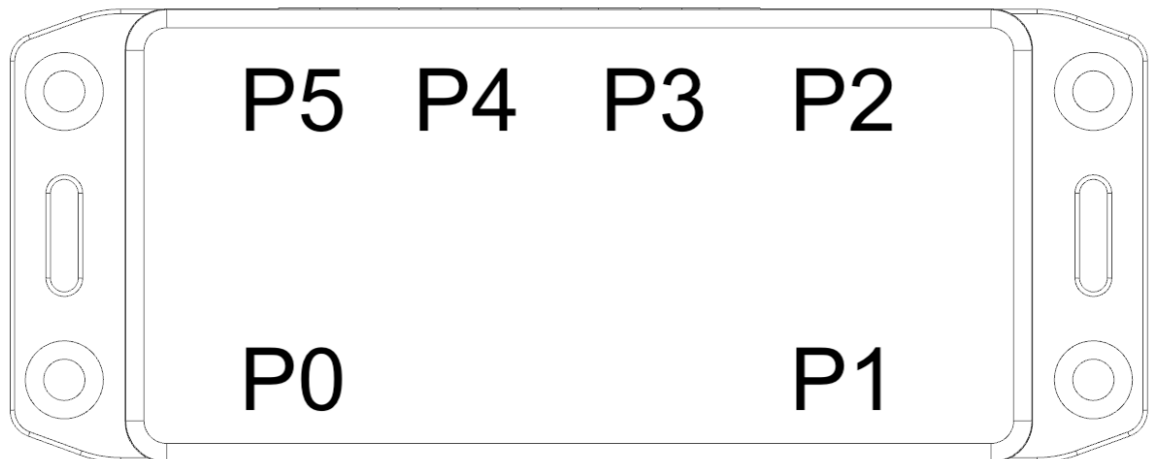

5.1.2 HUB LH-06 Rev. 2

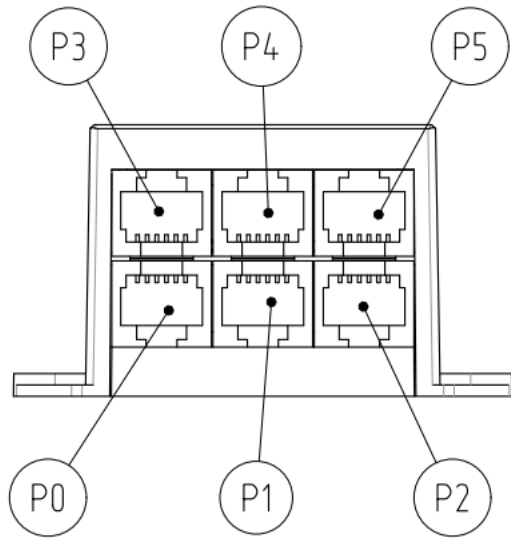

5.2 Configuration



Attention: When delivered, the number of controllers connected to the HUB is set to 6. This ensures that the system will not start operating, before all anticipated controllers are connected to the HUB. Once the system is set up, the actual number of connected controllers must be set through the menu 91. Without that, there will be no operation!

5.2.1 Connecting the controllers to the HUB

Controllers and control panels can be connected to all the 6 ports. The controllers will be connected by a 6P6C interface cable to the HUB. To any port connected to a control panel with height indication, a control panel without height indication can be added by using a Splitter-Adapter.

To be able to start a movement if 6 controllers are connected, either, at least on one port a control panel without height indication must be connected by use of an Injector-Adapter or at least one of the controllers must have a BLE-module or WiFi-module.

Only configured controllers can get connected to the HUB. The configuration is done in the same manner as for single use. **All controllers must have the same firmware version.**

5.2.2 Remaining ports

The ports not connected to controllers can be connected to control panels with or without height indication. By use of a Splitter-Adapter every port connected to a control panel with height indication can be connected to a control panel without height indication. All connected control panels will operate all drives connected to all the controllers plugged into the HUB, synchronously.

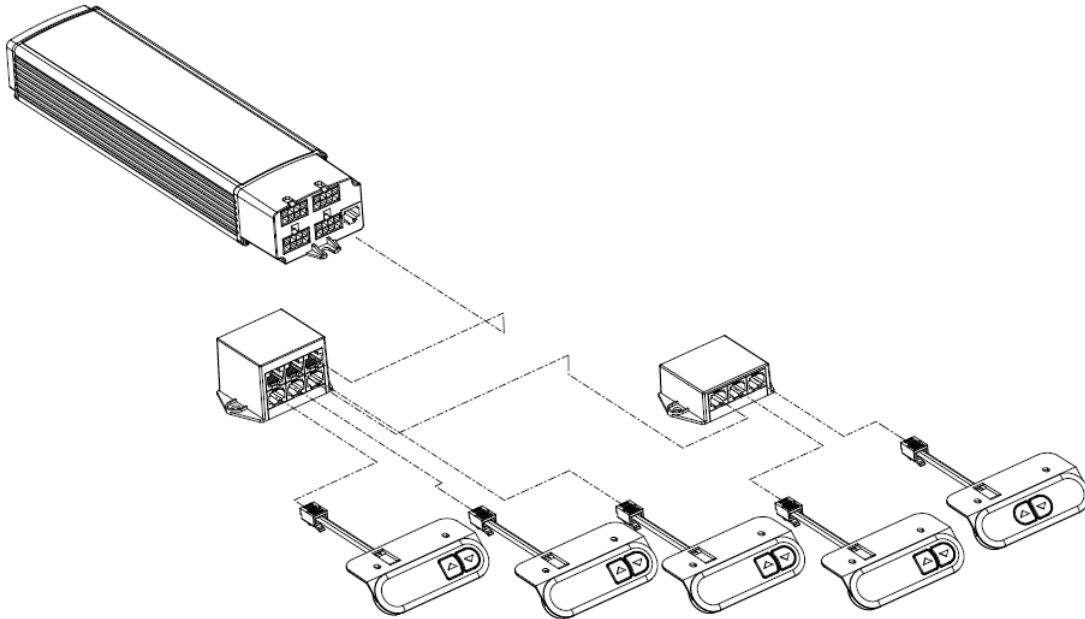

5.3 HUB startup

Throughout startup, the HUB will check how many controllers are connected to the HUB. This number will be compared to the number the HUB is configured for.

If the HUB detects the number of controllers it is configured for, the system can operate.

If the HUB detects more controllers, than it is configured for, the HUB will adjust the number of controllers required for operation to the number of controllers detected. From then on, the HUB requires this number of controllers to be operable.

If a smaller number of controllers is connected to the HUB than it is configured for, failure F24 will be shown, the system cannot operate. In this case the number of controllers must be set by the Service App or by Menu 91 to the actual value.

Unconfigured HUBs are set up for 6 controllers, so, unless 6 controllers are connected, the number of controllers must be set in any case by the menu 91. If

thereafter the number of controllers is reduced, then no operation will be possible. Failure F24 will be shown until at least the number of controllers the HUB is configured for is found by the HUB or the number is adjusted by the Service App or Menu 91. The HUB checks every port for controllers, not only the ports once already used by controllers!

The HUB will synchronize all drives of the connected controllers. For this it is mandatory that the parameters used for the movement of the drives are the same. This is why the HUB will check these parameters critical for the movement, should there be a discrepancy, the HUB will copy the parameters used for the movement from the controller connected to the lowest port number to all other controllers.

Now the HUB is ready to operate.

5.4 Operation

A movement of the connected drives can be initiated by all connected control panels, also by WiFi or BLE which might be installed in one or more of the connected controllers. Always the control panel used first will be and remain active, until the movement is done. After that another control panel can be used.

If another control panel is used while a movement is still in progress, all movements will be stopped.

5.5 Connecting a PC to the HUB

The HUB can be monitored and configured by the Service App. For that the HUB will be connected to the PC by an interface cable.

When the interface cable is plugged into port P1, the Service App can be opened. Here it is possible to set for example the number of connected controllers. When saving the configuration to the HUB, the changed values will be transferred to all connected controllers, and all controllers will be restarted. This process lasts several seconds; throughout this time no movement can be started.

5.6 Exchanging a controller

If a controller must be exchanged, the configuration in the HUB for this port can be transferred to the new connected controller. If this process is repeated, the configuration can be transferred to various controllers.

- a. Unplug the old controller from the HUB
- b. Choose the port on which the controller is going to be exchanged through the menu 92 and confirm

- c. Plug in the new controller into the selected port. The controller already must be connected to the mains
- d. The complete parameter set, not only the parameters relevant for the movement, is going to be loaded into the new controller.

5.7 HUB Menu handling

The HUB and the controllers connected to the HUB can be configured by the control panels with height indication. All menu items available for single controllers are usable except for:

Menu 50 to 53 (Info menu) and menu 40 to 46 (option menu)

In addition to that, the following menus are available that are required for the HUB only.

5.7.1 Restarting the HUB by the „LD“ control panel

Should the HUB not work anymore or should new recognition of the connected controllers be required, the HUB can be restarted. Thereafter the HUB will search for controllers for 5 seconds.



- Press the “up” arrow key 4 times quickly one after another



- The display will now show “P01”
- Press the “up” or “down” arrow key until the display shows “P17”



- Press the memory key “one” shortly to enter the menu
- The display now will show “P90”
- Press the memory key “one” shortly to restart the HUB
- To leave the menu item press the memory key “two”, the HUB will continue operating

5.7.2 Deleting the configurations stored in the HUB by the “LD” control panel

With this menu the configurations stored in the HUB will be deleted and the number of connected controllers will be set to zero. After deletion, the configurations of the connected controllers will be copied into the HUB, and the number of the connected controllers will be stored.



- Press the “up” arrow key 4 times quickly one after another
- The display will now show “P01”
- Press the “up” or “down” arrow key until the display shows “P17”
- Press the memory key “one” shortly to enter the menu “P90”



- Press the “up” or “down” arrow key until the display shows “P91”
- Press the memory key “one” to select the menu item
- Now the present controller number the HUB is set for is shown
- Press the “up” or “down” arrow key until the display shows “0”
- Press the memory key “one” shortly to reset and restart the HUB

5.7.3 Adjusting the number of controllers connected to the HUB by “LD” control

panel

When an unconfigured HUB is supplied, the number of connected controllers is set to 6. That means that the HUB will only operate when 6 controllers are connected. This setting ensures that the HUB cannot be operated before all desired controllers are connected and the right number of controllers is entered into the HUB by this menu item.



- Press the “up” arrow key 4 times quickly one after another
- The display will now show “P01”



- Press the “up” or “down” arrow key until the display shows “P17”
- Press the memory key “one” shortly to enter the menu “P90”
- Press the “up” or “down” arrow key until the display shows “P91”
- Press the memory key “one” to select the menu item



- Now the present controller number the HUB is set for is shown
- Press the “up” or “down” arrow key until the display shows the desired number of controllers



- Press the memory key “one” shortly to save the number to the HUB
- If at the next startup more controllers will be connected, the HUB automatically will save the actual number. Should the number of connected controllers be reduced thereafter, the number must be adjusted again through this menu item, as for safety reasons the number of the connected controllers cannot be smaller than the number the HUB is set to.

5.7.4 Choosing the HUB port for transferring the configuration by “LD” control

panel

If a controller should get exchanged, the configuration stored in the HUB for this port can be transferred into the new controller. Therefore, the port must be selected from the following menu.

- Press the “up” arrow key 4 times quickly one after another

- The display will now show “P01”
- Press the “up” or “down” arrow key until the display shows “P17”
- Press the memory key “one” shortly to enter the menu “P90”
- Press the “up” or “down” arrow key until the display shows “P92”
- Press the memory key “one” to select the menu item
- Press the “up” or “down” arrow key until the display shows the port, from which the configuration should be transferred
- Press the memory key “one” to select the port and to activate the transfer
- After the transfer is completed, the port continues with its regular operation

5.7.5 Displaying the last error in HUB mode by “LD” control panel

If the control panel displays an error in the HUB mode, it is possible to check through the menu on which drive the error occurred.

- Press the “up” arrow key 4 times quickly one after another
- The display will now show “P01”
- Press the “up” or “down” arrow key until the display shows “P15”
- Press the memory key “one” to select “P76”
- Depending on which port of the HUB is affected by the error, a number between 70 and 75 will be displayed
- Press the memory key “2”, then press the “up” or “down” arrow key until the display shows the menu which was shown in P76. When “e.g. 72” was shown, the menu “P72” must be selected
- Press the memory key “one” shortly to display the 3-figured error code. The first figure shows which drive is affected (motor output 1-4), the second and third figures show the error
- Errors which aren’t drive-specific, like for example “power supply overload” are displayed with 2 figures only

5.7.6 Connecting 6 Controllers to the HUB

If 6 controllers are to be connected to a HUB, an injector adapter is required. This adapter connects an LM control unit and the HUB to one controller, allowing all controllers connected to the HUB to be operated via this unit.

This is only necessary if none of the controllers are equipped with WiFi or BLE.

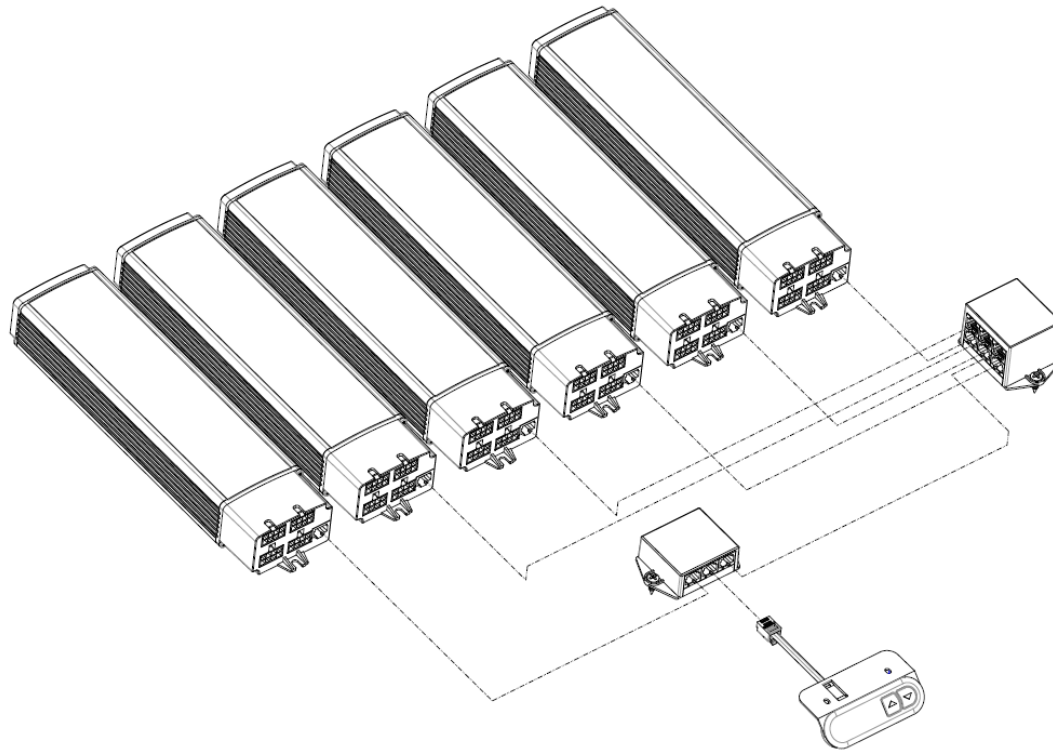

6 BLE Option

Controllers with BLE option have a BLE module integrated in the controller which can communicate with other BLE enabled devices and with the wireless control panels. This option allows you to operate the table through an app or and it enables the controller to provide information about its status and or movements to an app.

The BLE module identifies itself with the serial number of the controller, so even when more controllers are equipped with BLE the desired controller can be identified. Through the app or the Wizard, the controller can be given a name, what then will be shown instead of the serial number.

The BLE module can provide all information available inside the controller, for example to an app.



Attention: When controlled through an app, moving the table is possible without visual contact to the table. It must be made sure that the table will be observed throughout any movement to avoid injury!

7 WiFi Option

Controllers with WiFi option have a WiFi module installed inside the controller that can connect to and communicate with WiFi networks. This allows the controller to be controlled, for example by higher level controls. The network the controller should connect to can be entered by the Wizard to the controller. After

the SSID and the passcode have been entered, the controller connects automatically to the network. Then the full functionality of the controller and all information inside the controller can be initiated and accessed through WiFi. The controller identifies itself in the network by its serial number or by the name assigned to it.



Attention: When controlled through WiFi moving the table is possible without visual contact to the table. It must be made sure that the table will be observed throughout any movement to avoid injury!

8 TCP-Adapter

The TCP adapter converts the standard integrated Modbus RTU into Modbus TCP.



9 Status and failure modes indicated by the LED

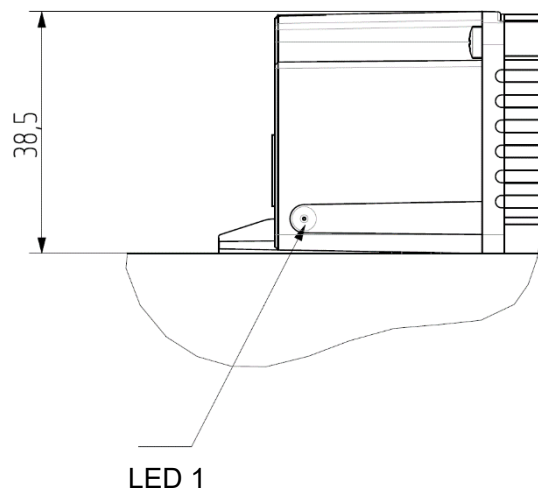

The LED on the controller indicates the following:

Indicated code	Meaning	Failure solution
Constantly on	Controller is switched on and / or motors are running	If LED is not on, check the power cable
Single blink	Controller is in standby mode	Press a button on the keyboard to initiate a movement
Constantly blinking	Controller is in reference mode	Press up or down button to perform a reference run. Keep button pressed until the reference run is finished!
Short and long blinks, SOS Short short short Long long long Short short short	The LED shows a sequence of long and short signals.	If a control panel with digital height adjustment is connected, read out the failure code. In case of a control panel without digital height indication by reading out the SOS flash sequence a failure identification is not possible.

9.1 Menu codes for control panels without height indication “LM”

The control panels without display indicate the actual menu item by sounds created when entering the various menu items.

Indicated menu	Meaning	Explanation
PM1 one sound	Store memory positions	The memory positions for the control panel memory keys can be stored
PM2 two sounds	Set user upper and lower limit	Users can set individual upper and lower limits for their controller to avoid e.g. collision with a window board above or drawer container below the table
PM3 three sounds	Adjust sensitivity of collision detection	For the current based as well as the GyroSense and GraviSense based collision detection here the sensitivity can be adjusted. Also, the collision detection can be deactivated
PM4 four sounds	Initiate Reference mode	If the table gets out of level a reference run can be initiated in this menu item
PM5 five sounds	Change from metric to imperial units	Here the indicated units can be changed from metric to imperial and back

9.2 Menu codes indicated by “LD” control panels

The following menu code indications will be shown by the control panels with height indication. If control panels without height indication are used, refer to the sounds created when entering the various menu items.

Indicated menu	Meaning	Explanation
P1	Store memory position 1 (remains only for compatibility reasons, use four key presses instead)	The memory position one for the control panel memory key one can be stored
P2	Store memory position 2 (remains only for compatibility reasons, use four key presses instead)	The memory position two for the control panel memory key two can be stored
P3	Store memory position 3 (remains only for compatibility reasons, use four key presses instead)	The memory position three for the control panel memory key three can be stored
P4	Store memory position 4 (remains only for compatibility reasons, use four key presses instead)	The memory position four for the control panel memory key four can be stored
P5	Memory key handling	Users can select if the memory key must be kept pressed until the memory position is reached or if a short key press is sufficient
P6	Set user lower limit	Users can set individual lower limits for their controller to avoid e.g. collision with a drawer container below the table

P7	Set user upper limit	Users can set individual upper limits for their controller to avoid e.g. collision with window board
P8	Sensitivity level for the collision detection	For the current based, as well as the GyroSense and GraviSense based collision detection in this menu item the sensitivity can be adjusted. Also, the collision detection can be deactivated
P9	Initiate reference mode (remains only for compatibility reasons, use four key presses instead)	If the table gets out of level or the height is not indicated right, a reference run can be initiated in this menu item
P10	Change from metric to imperial units	In this menu item the indicated units can be changed from metric to imperial
P11	Enter info menu	This menu item leads to the information menu
P12	Enter service menu	This menu item leads to the service menu
P13	Enter option menu	This menu item leads to the option menu
P14	Enter reset menu	This menu item leads to the reset menu
P15	Enter error menu	This menu item leads to the error menu

P17	Enter HUB menu	This menu item leads to the HUB menu (only when connected to HUB!)
Service menu		
P30	Reset user settings	All user settings will be reset to the factory settings
P31	Distance from top endpoint	Set the distance from the top endpoint the travel will stop
P32	Distance from bottom endpoint	Set the distance from the bottom endpoint the travel will stop
P33	Distance from the floor	Set the distance from the floor the display will indicate
P34	Display precision	Set if the indicated value is rounded to 0.1, 0.5 or 0.0
P35	Start of the safety zone	Set the starting point of the safety zone
Option menu		
P40	Activate BLE	Activate or deactivate the BLE
P41	Reset controller name	Controller name will be reset to the serial number

P42	Enter pairing mode	Activate pairing mode for the controller to connect a wireless control panel
P43	Clear paired control panels	All connections to control panels saved in the controller will be deleted
P44	Reset private mode	The private mode for the controller will be deactivated
P46	Activate WiFi	Activate or deactivate the WiFi
Info menu		
P50	Charging state of the battery	Shows the current charging state of the battery in percent
P51	Battery temperature	Shows the current temperature of the battery
P52	VendorID	Shows the last 3 figures of the vendor product ID
P53	Controller voltage	Shows the controller voltage
Reset menu		
P60	Motor number	Adjust/reset the number of motors set in the controller

P61	Safety mode	Reset safety mode to auto detect mode
P62	Reference run downwards/upwards	Select whether reference run is done downwards or upwards
P63	Stroke detection	Repeat the stroke detection, when "one-time" stroke detection is activated
Error menu		
P76	Last error	Displaying the last error
HUB menu		
P90	Restart HUB	The HUB can be restarted with this menu item
P91	Delete configurations	Configurations stored in the HUB will be deleted and the number of controllers will be set to 0
P92	HUB port for transferring configuration	HUB port from which stored configurations should be loaded into a new controller can be selected

9.3 Failure codes indicated by control panels

Throughout regular operation the LED is constantly on. In standby mode the LED blinks once every 5 seconds.

The following failure indications will be shown by the control panels with height indication. If control panels without height indication are used, an error will be shown through the LED by a SOS blinking sequence (short short short long long long short short short)

Indicated Failure code LED blinking	Failure	Failure solution
con	Communication error	There is no communication between the controller and the control panel. Check the electrical connection
- - - fast blinking of the LED	Reference mode	The controller entered reference mode; a reference run must be performed
F1	EEPROM initialization error	Reset error by pressing any key If the error remains restart system by unplugging the power cable of the controller and plugging it in again after 20 seconds If the error reoccurs the controller may be damaged, contact the supplier
F2	EEPROM write error	Reset error by pressing any key If the error remains restart system by unplugging the power cable of the controller and plugging it in again after 20 seconds

		If the error reoccurs the controller may be damaged, contact the supplier
F3	EEPROM Read error	<p>Reset error by pressing any key</p> <p>If the error remains restart system by unplugging the power cable of the controller and plugging it in again after 20 seconds</p> <p>If the error reoccurs the controller may be damaged, contact the supplier</p>
F4	EEPROM inconsistency error	<p>Reset error by pressing any key</p> <p>If the error remains restart system by unplugging the power cable of the controller and plugging in again after 20 seconds.</p> <p>If the error reoccurs the controller may be damaged, contact the supplier</p>
F5	Collision detected through GyroSense, GraviSense or current based collision detection	<p>Reset error by pressing any key</p> <p>Should errors reoccur, decrease sensitivity level of the collision detection through the control panel menu system</p>
F6	Motor current reached the overcurrent stop level	Reduce load on the table

		Reset error by pressing any key
F7	Motor current reached the error overcurrent level.	Reduce load on the table Reset error by pressing any key
F8	Motor current reached the fault overcurrent level.	Try to reduce load on the table or ensure a smoother travel path of the table mechanism Reset error by pressing any key
F9	Maximum allowed energy amount (E_{lim}) entered into the motors.	Wait for some time, to allow the motors to cool back. The E_{lim} decrease mechanism allows partial usage of the system after a one-minute wait time, however for a complete cool back, around 13 minutes are required Reset error by pressing any key
F10	Maximum allowed energy amount (E_{lim}) supplied by the controller	Wait for some time to allow the controller to cool back. The E_{lim} decrease mechanism allows partial usage of the system after a one-minute wait time, however for a complete cool back, around 13 minutes are required Reset error by pressing any key

F11	Maximum temperature level of the controller main power supply reached	Wait for some time to allow the controller main power supply to cool back Reset error by pressing any key
F12	Maximum temperature level of the controller's motor one and two drive reached	Wait for some time to allow the controller to cool back Reset error by pressing any key
F13	Maximum temperature level of the motor three and four drive reached	Wait for some time to allow the controller to cool back Reset error by pressing any key
F14	The maximum height difference between the table legs was exceeded	The system enters reference mode automatically Execute reference run by keeping pressed up or down key of the control panel until reference run is done
F15	Motor blocked or so overloaded that it cannot speed up	Try to reduce load on the table or ensure a smoother travel path of the table mechanism Reset error by pressing any key

F16	Number of motors connected to the controller does not correspond to the number of motors the controller was configured for	<p>Check if all motors are properly connected to the controller</p> <p>Reset error by pressing any key</p>
F17	Controller overloaded	<p>Reset error by pressing any key</p> <p>If the Error remains restart system by unplugging the power cable of the controller and plugging it in again after 20 seconds</p> <p>If the error reoccurs the controller may be damaged, contact the supplier</p>
F18	Hardware failure	<p>Reset failure by pressing any key</p> <p>Should the failure remain, separate controller from the mains for 20 seconds</p> <p>Should the failure remain, contact the supplier</p>
F19	Wrong sequence of the drives	<p>The drives must be connected in sequence to the controller, starting with 1, then 2,3,4. There cannot be a gap between two successive controllers</p>



F20	Safety-adapter missing	<p>The controller is configured for a safety-adapter; however, a safety-adapter is not connected</p> <p>Connect a safety-adapter!</p>
F21	Safety-adapter active	<p>The safety adapter has been triggered</p> <p>Remove the reason for the safety-adapter trigger and push the button again</p>
F22	One of two hall-sensors is not giving any signal	Check hall-sensors and cable
F23	Controllers with different parameter sets are connected to the HUB / Syny-Y-Adapter	Connect controllers with similar parameter set ID
F24	Number of connected controllers to the HUB is smaller than number for which the HUB is configured	Correct number of controllers in the Wizard or through menu 91 with the control panel or connect the correct number of controllers



F25	The battery reached the overcurrent level	Reduce load of the table
F26	Battery short-circuit	Solve short-circuit
F27	Battery overvoltage	Battery may be damaged, contact the service
F28	Battery undervoltage	Connect battery to charger
F29	Internal battery error	Push the button on the battery pack 8 times shortly one after another Should the error remain, contact the service
F30	Low battery power	Battery isn't capable to give the required performance anymore, connect battery to charger

F31	battery temperature out of range	Temperature of the battery cells over 45°C/ 113°F → let battery cool down under 10°C/ 50°F → bring battery temperature in the permitted range
F32	Firmware versions of controllers connected to the HUB or Sync-Y-Adapter are not similar	Use controllers with similar firmware versions

10 Sound signals

The following sound signals are given out by the controller:

Sound	Meaning	Explanation
	Acknowledgement signal	The sound acknowledges a selection
	Fail signal	The sound indicates that a selection could not be made as intended

	<p>Deletion confirmation</p>	<p>The sound indicates that a value has been deleted like the user height</p>
	<p>OK Signal</p>	<p>The sound confirms a selection</p>

11 Directives and approvals

11.1 Directives followed

RoHS 2. 2011/65/EU

Reach 2006/121/EC

Low voltage 2014/35/EU

EMC 2014/30/EU

11.2 Approvals for European Controllers (230V versions)

The CE sign is based on the compliance to the following standards:

EN 60335-1 2012

EN 61000-6-3 2007

EN 61000-6-2 2005

EN 61000-3-2 2006+A1 2009+A2 2009

EN 61000-3-3 2008

EN 62233 2008

ISO 13849-2 Performance level „B“

11.3 Approvals for USA and Canada (115V versions)

ETL Mark Approval is based on the following standards:

ANSI/UL 60950-1:2007+A1+A2

CAN/CSA-22.2 No. 60950-1:2007+ A1+A2

Revision_11_E, 07.07.2021



LAING INNOTECH

Declaration of Conformity

We, **Laing Innotech GmbH & Co. KG.**, Theodor-Heuss-Str. 23 D-71566 Althütte, declare under our sole responsibility that the products

Product: Motor Controller
Models: LTC 302, LTC383, LTC384

to which this declaration relates, is in compliance with the following documents:

Directives: 2014/35/EU Low Voltage Directive
2014/30/EU EMC Directive
2011/65/EU RoHS Directive

Product Safety Standard: IEC 60335-1:2010 + AMD1:2013

EMC Standards: EN 61000-6-1:2007
EN 61000-6-2:2005
EN 61000-6-3:2007+A1
EN 61000-6-4:2007+A1



Althütte, 15th of July 2021

Manufacturer's representative