

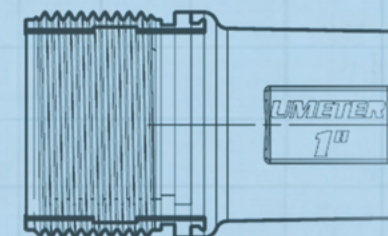

# Umeter®

## ULTRASONIC WATER METER USER MANUAL

About & Safety
Umeter® Overview
Installation
Outputs
LCD Reference
Smart Protocol
Specifications





Umeter® Clamp



Umeter® N-Line

## About Umeter®

The SunSonic Umeter® ultrasonic water meter uses ultrasonic sound waves to detect large flow ranges with the highest accuracy by using ultrasonic technology and no moving parts. The Umeter® is designed to simplify the installation and maintenance of ultrasonic water meters. It provides three different communication outputs, enabling users to track and manage their meter data remotely with multi-device connectivity. There are two versions of Umeter®:

- **Umeter® Clamp**
- **Umeter® N-Line**

The SunSonic Umeter® Clamp can be installed in any orientation, angle, and/or direction. This offers a simplified installation and supplies accurate data over its entire lifetime while guaranteeing no leaks during or after its installation. Its patent-pending clamp design works on CPVC, PEX type A, B as well as Copper type L, M.

The SunSonic Umeter® N-Line is SunSonic's solution to the traditional in-line ultrasonic water meter design. The Umeter® N-Line can be installed in any orientation, angle, and/or direction. Its patented design uses a low-pressure loss flow tube comprised of a polymer material made of 50% fiberglass. Its patented, integrated brass-threaded ends enable a secure installation and create a fortified fit.

## Safety Information

The installation of any Umeter® product must comply with all relevant local, state, and federal rules, codes, and regulations. Failure to read and follow these instructions may lead to improper use, wrongful application or mishandling of the Umeter®, which could lead to personal injury or equipment damage.



# Umeter® Clamp Overview

## Applications:

The Umeter® Clamp minimizes installation time by clamping onto CPVC/Copper L, M or PEX A, B piping to supply accurate data throughout its entire lifetime.

## Standard Features:

The Umeter® Clamp is NTEP\* certified to be used in any orientation, angle, and/or direction. It was designed to offer an installation experience unsurpassed in speed and efficiency. With its patent-pending clamp, this ultrasonic water meter is guaranteed to cause no leaks during and after its installation. The Umeter® Clamp meets AWWA C715 accuracy, is UL certified and listed with UL 1951 and UL 2043, and offers the most versatile communication output for any ultrasonic water meter.

## Umeter® Clamp Design:

The patent-pending clamp design enables the user to clamp the ultrasonic meter to a pipe without any tools, plumbing expertise, or materials with the confidence the installation will never cause leaks. This innovative design saves both time and installation costs, is available for 3/4-inch and 1-inch pipe diameters, and can be used on CPVC/Copper type L, M, and PEX type A, B pipe material.

# Umeter® N-Line Overview

## Applications:

The Umeter® N-Line is a patented design comprised of its low-pressure loss tube, patented, integrated brass threading, and its fortified polymer material to provide highly accurate water flow data throughout its entire lifetime.

## Standard Features:

The Umeter® N-Line is NTEP\* certified to be used in any orientation, angle, and/or direction. With its patented design, this ultrasonic meter is made to withstand potential damage during its installation process, as well as be a robust and resilient ultrasonic water meter in its field of use. The Umeter® N-Line meets AWWA C715 accuracy, is NSF certified, contains no moving parts, and is UL certified and listed with UL 1951 and UL 2043.

## Umeter® N-Line Design:

The patented N-Line design combines its low-pressure loss tube, patented-integrated brass-threaded end connections, and its polymer material for maximum pressure capabilities. The tube of the N-Line is a robust polymer material containing 50% fiberglass. It is available for 3/4-inch and 1-inch pipe diameters.

### Umeter® Unboxing

- LCD may be blank until its ambient light sensor detects light.
- If no light is detected after a period of time, the display will return to a blank state.
- The Empty Pipe icon (  ) should be active. Icon will deactivate after a successful installation.

Ambient light sensor



\* NTEP 24-003, certified for use in California and areas where required.



# Installing Umeter® Clamp

## Indoor installation only

### Preparation

1. Confirm the pipe type coincides with the meter model.

**Example:** Umeter®-C-PEX-075



2. Clean the couplant, thermistor, and pipe surfaces with a 70% isopropyl alcohol cleaning wipe or equivalent.
3. Ensure installation location is **10x pipe diameter** from any elbows, valves, and fittings upstream.

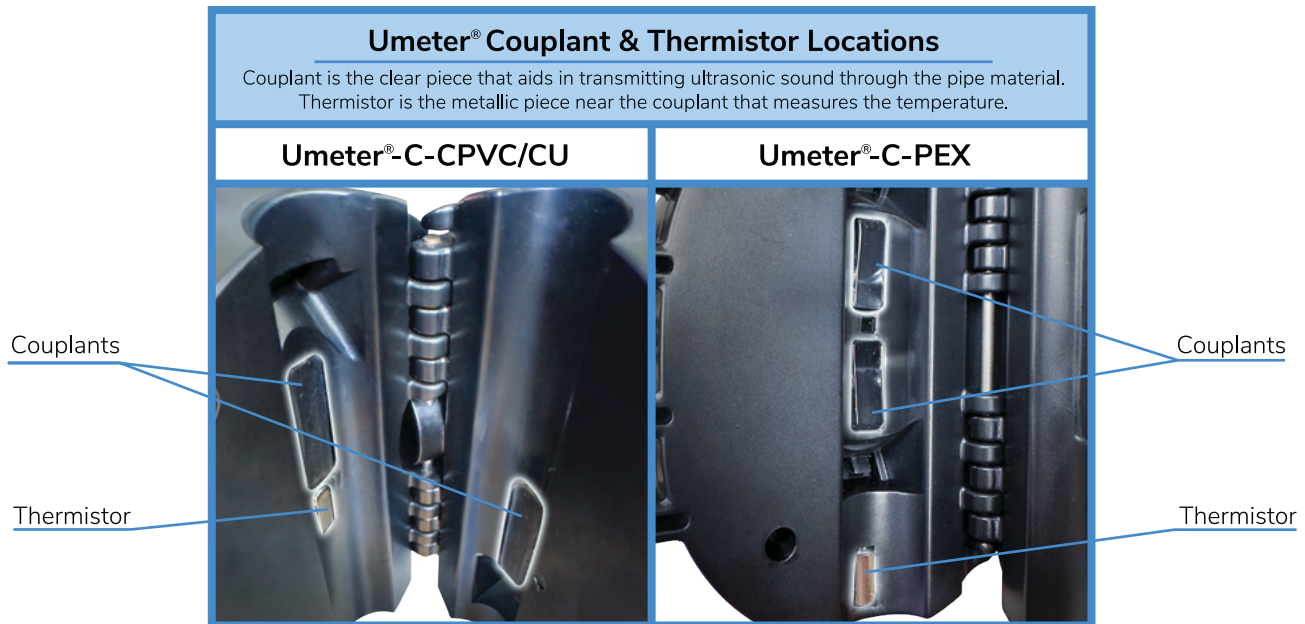

### Installation

**NOTICE: installation is suitable for any direction, orientation, and angle.**

1. When unboxing the meter, the LCD may be blank until its ambient light sensor detects light.
  - A. Empty Pipe (🚰) icon should be active (on) until properly installed.
2. Verify the meter surfaces and pipe surfaces are free from debris, stickers, oil, and other contaminants.
3. Confirm the pipe's water flow direction coincides with the "FLOW" arrow on the meter body.
  - A. Ensure installation location is **10x pipe diameter** from any elbows, valves, and fittings upstream.
4. Clamp the meter onto the pipe. Bring the clamp into its closed position.



Unlocked



Closed

5. Ensure the pipe is full of water and confirm the Empty Pipe icon is deactivated (off) for a proper installation.





# Installing Umeter® N-Line

## Indoor installation only

### Preparation

1. Confirm the pipe type coincides with the meter model.

Example: Umeter®-N-1



2. Confirm the pipe's water flow direction coincides with the "FLOW" indicators on the meter body.
3. Close the water supply valve.

### Installation

**NOTICE: installation is suitable for any direction, orientation, and angle.**

1. When unboxing the meter, the LCD may be blank until its ambient light sensor detects light.
  - A. Empty Pipe (🚰) icon should be active (on) until properly installed.
2. Verify the meter's brass threaded ends are free from debris, oil, and other contaminants.
3. Place the meter in line with the piping and confirm the pipe's flow direction coincides with the "FLOW" indicators on the meter body.
4. Tighten enough to create a seal.
5. Gently open the upstream valve to allow water to flow.

**NOTE: opening the valve too quickly may cause damage to the meter.**

6. Test for leaks.
7. Ensure the pipe is full of water and confirm the Empty Pipe icon is deactivated (off) for a proper installation.



## Outputs

The Umeter® provides the most versatile communication output by supplying three output options per meter:

- Pulse output - contact closure type output.
- Encoded output (Sensus Protocol) - used on encoded device, limited data.
- Smart output- used on devices and coincides with Smart Protocol.

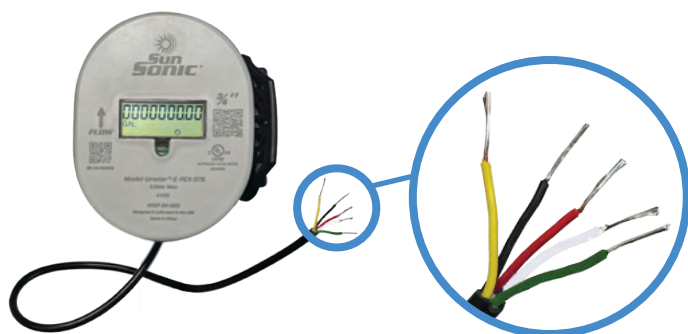

Output	Umeter® Wire	Function
Pulse	Red	PLS +
	White	PLS -
Encoded / Smart*	Black	GND / COM
	Green	TX / DATA
	Yellow	RX / CLK

\* The Umeter® comes standard with Pulse output and Encoded output. Smart output is available on request.



# Umeter® LCD





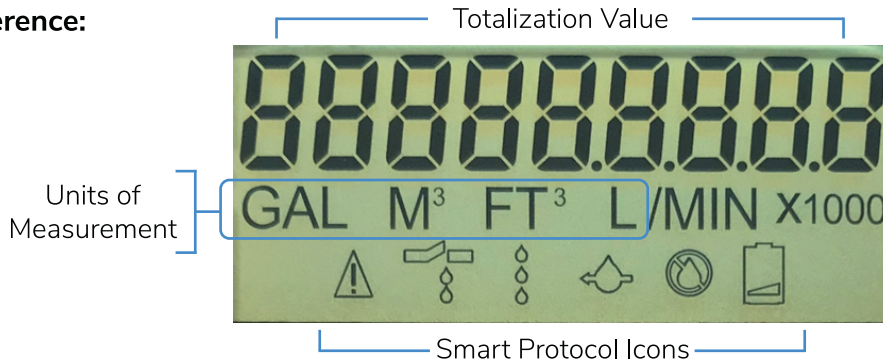

## Umeter® Display

The Umeter® will show real-time totalization when water flow is detected.

## Umeter® LCD Reference:



# LCD Icon Reference

Description	Alarm Indication	Alert Activation/Deactivation
 General Alerts - Alarms indicated by several blinks. - Multiple alarms have a longer pause between each alarm.	No water usage for 30 days. One blink.	Alarm activates after no normal flow is detected for 30 consecutive days. Alarm automatically deactivates after normal flow is detected.
	Minimum Water Temp. Two rapid blinks.	Alarm activates when lower water temperature limit is exceeded. Meter will continue to operate but outside of its specified range. Alarm deactivates 60 days after being within its range.
	Maximum Water Temp. Three rapid blinks.	Alarm activates when upper water temperature limit exceeded. Meter will continue to operate but outside of its specified range. Alarm deactivates 60 days after being within its range.
	Low Signal Four rapid blinks.	Alarm activates when signal interference/signal issue is detected. Meter continues to operate unless a catastrophe is encountered. Alarm clears after 60 days of being within a normal signal state.
 Suspected Burst Pipe		Alarm activates when maximum flow rate is exceeded. No consumption is recorded until the flow rate returns to its normal range. Alarm deactivates when within normal flow range.
 Suspected Leak		Alarm activates after 24 consecutive hours of flow between minimum and normal rate (leak window). Alarm deactivates after the meter detects 15 consecutive minutes of flow or no flow.
 Reverse Flow		Alarm is activated immediately upon detecting 4 gpm of reverse flow (flow opposite of flow indicator on the meter). Alarm deactivates after 60 days unless the alarm event has reoccurred.
 Empty Pipe		Alarm is activated immediately when the pipe is not full or partially full. Alarm deactivates when the pipe becomes full or after a successful installation.
 Battery Indicator		Alarm activates when there is 1 year of battery life remaining or a battery issue is detected.

# Smart Protocol

Smart Protocol remotely informs the user of the current status of the Umeter®.

- These coincide with the alarms that are displayed on the Umeter® LCD\*.
- All Smart Protocols activate and deactivate based on the same parameters as the Umeter® alert icons.
- Smart Protocol must be connected. Refer to your wireless device manufacturer.

\* LCD totalization value is ultimately the correct value versus any other device connected to the pulse wires.

\*\* Umeter® models ordered with Smart Protocol are labeled with "-SMP" and are programmed exclusively for Smart Protocol.



# Clamp Specifications

Umeter® Ultrasonic Meter Size	3/4 inch	1 inch
Normal Test Flow Limits	0.5 - 35 gpm	0.75 - 55 gpm
Minimum Test Flow Rate	0.05 gpm	0.15 gpm
Safe Maximum Operating Capacity (SMOC)	35 gpm	55 gpm
Typical Pressure Loss	None. The Umeter® Clamp is clamped around the existing pipe.	
Meter Flow Orientation	Any orientation, angle, and/or direction.	
Pipe Type	CPVC/Copper L and M, PEX A and B.	
Operating Characteristics	<ul style="list-style-type: none"> <li>+/- 1.5% over normal flow range.</li> <li>+/- 5.0% minimum to normal flow range.</li> </ul>	
Storage Temperature	-20° - 140°F (-28.9° - 60°C).	
Measured-fluid Temperature Range	36° - 90°F (2.2° - 32.2°C).	
Installation Location	Indoor only.	
Register Type	LCD.	
Totalization Display Resolution	<ul style="list-style-type: none"> <li>Gallons: 0. XX</li> <li>Cubic feet: 0.XXX</li> <li>Cubic meters: 0.XXXX</li> <li>Liters: 0.X</li> </ul>	
Battery	Replaceable 10-year battery life.	

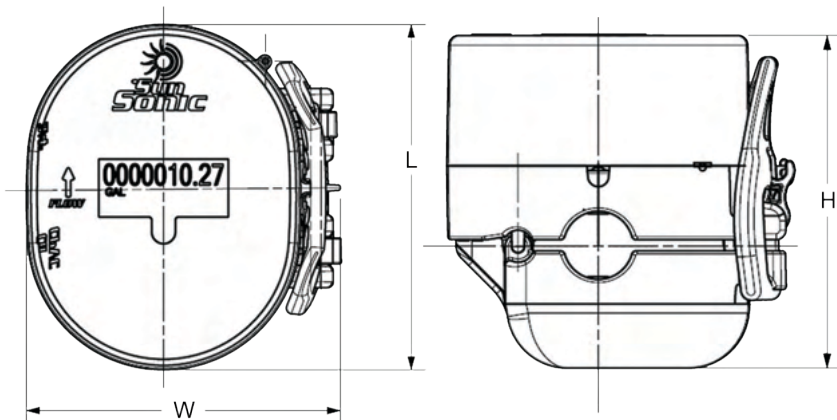

Umeter® Clamp Series Size	-075			-1		
	L	W	H	L	W	H
Umeter®-C-CPVC/CU	4.78 in.	4.30 in.	4.14 in.	4.78 in.	4.30 in.	4.25 in.
Umeter®-C-PEX	4.78 in.	4.30 in.	3.32 in.	4.78 in.	4.30 in.	3.32 in.



# N-Line Specifications

Umeter® Ultrasonic Meter Size	3/4 inch	1 inch
Normal Test Flow Limits	0.5 - 35 gpm	0.75 - 55 gpm
Minimum Test Flow Rate	0.05 gpm	0.15 gpm
Safe Maximum Operating Capacity (SMOC)	35 gpm	55 gpm
Typical Pressure Loss	2 psig max.	
Meter Flow Orientation	Any orientation, angle, and/or direction.	
Operating Characteristics	<ul style="list-style-type: none"> <li>• +/- 1.5% over normal flow range.</li> <li>• +/- 5.0% minimum to normal flow range.</li> </ul>	
Storage Temperature	-20° - 140°F (-28.9° - 60°C).	
Measured-fluid Temperature Range	36° - 140°F (2.2° - 60°C).	
Installation Location	Indoors only.	
Maximum Operating Pressure	175 psi.	
Register Type	LCD.	
Totalization Display Resolution	<ul style="list-style-type: none"> <li>• Gallons: 0. XX</li> <li>• Cubic feet: 0.XXX</li> <li>• Cubic meters: 0.XXXX</li> <li>• Liters: 0.X</li> </ul>	
Battery	Replaceable 10-year battery life.	

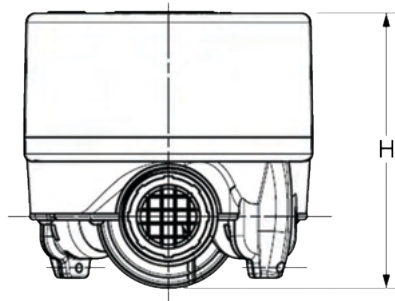
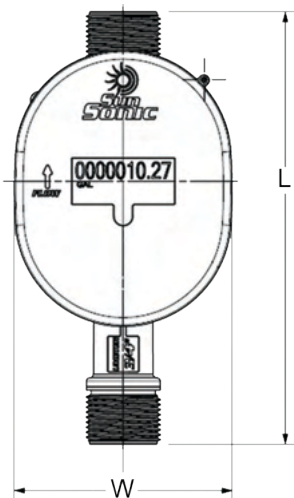

Umeter®-N-Line Series Size	-075			-1		
	L	W	H	L	W	H
Umeter®N	7.50 in.	3.78 in.	3.60 in.	10.75 in.	3.78 in.	3.76 in.