



900 N. 400 W. Ste. 11  
North Salt Lake, UT 84054

## 9000 SERIES OPERATOR'S MANUAL



Produced by General Water Technologies

Thank you to our loyal customers!

Contact: 888-586-5654 M-F 8:00 AM – 5:00 PM MST (message prompt after hours for emergency response 24/7)  
Service: [service@genwater.com](mailto:service@genwater.com)  
Sales: [sales@genwater.com](mailto:sales@genwater.com)  
Orders: [orders@genwater.com](mailto:orders@genwater.com)  
Accounting: [accounting@genwater.com](mailto:accounting@genwater.com)

## **INDEX**

<b>Safety References</b>	<b>3</b>
<b>Specifications</b>	<b>4</b>
<b>Water Purity Conversion Charts</b>	<b>5</b>
<b>Purification Process</b>	<b>6</b>
<b>Continuous Decontamination</b>	<b>6</b>
<b>System Features</b>	<b>7</b>
<b>Startup</b>	<b>8</b>
<b>Flow Chart</b>	<b>9</b>
<b>D.I. Canister Replacement</b>	<b>10</b>
<b>Filter Replacement</b>	<b>10</b>
<b>Recommended Filter &amp; Membrane Replacement Schedule</b>	<b>11</b>
<b>Making a connection with Push-Fit Fittings</b>	<b>11</b>
<b>Daily Checklist</b>	<b>12</b>

## Safety References

This water purification system complies with state-of-the-art standards in terms of technology and safety regulations. All parts have been produced and or manufactured by preferred vendors to GWT specifications, and then assembled by GWT personnel (henceforth “supplier”) according to our proprietary design.

The supplier has taken all precautions to ensure safe operation. Users must ensure that the installation is performed in a manner that the method/mode of operation will not be affected. A signature at installation verifies that this is the case. Return visits to amend this placement will be subject to additional fees.

The system is supplier factory-approved and fulfills our safety standards.

***Please read the following safety precaution before start-up and comply with them during operation.***

The system must be operated by trained staff. Users should read this manual prior to utilizing this equipment.

The user is allowed to carry out only that maintenance work described in this manual or provided at training by the installation team. Only use designated spare parts for maintenance work.

The system must be connected to a fused, grounded power supply.

If leaks in the system become evident, the unit must be isolated immediately from the electrical supply and the fault rectified. If required, inform your suppliers customer service department.

Carry out maintenance and inspections as recommended by the supplier at the recommended intervals to insure user-safety and optimal system performance.

The supplier does not take any responsibility for injuries to users caused by improper application of this system, including negligence or abuse.

# Specifications

## Basic System Info (per system)

Model	GWT 9000
Production Capability	150 l/h max
Delivery (Peak Flow) Capability	4 gpm
Footprint (System face on)	24" depth x 14" wide x 60" tall
System Weight (floor mount only)	315 lbs in operation
Footprint w/Pan & Pump Kit	25" x 25" square, 2" lip, (system and all components fit inside footprint)
Door Hinge	Right, opening left to right
RO Pressure (Range)	80 - 175 PSI
Delivery Pressure	As Indicated by instrumentation, adjustable
Dispense Tap for Manual Fill	Included
Manual feed by lab in event of water outage	Not included in this model
Touchscreen Interface	Not included in this model
Live Remote Viewing	Not included in this model
Audible Leak Detection/Alarm	Not recommended
GWT 2000 DI Canister Consumable Footprint	Not included in this model
LC 123 Carbon Filters	Inside door, daily vigilance required, exchange as necessary
Startup Amperage	6-7 AMP
Running Amperage	3-4 AMP

## Presite Requirements (per system)

Domestic Water Feed to Equipment	3/4" Supply line w/ 3/4" dedicated drop to unit
Connection to Domestic 3/4" Line	3/4" FNPT ball valve
Minimum Pressure	50 PSI
Pressure Gauge	Upstream side of 3/4" FNPT ball valve
Power Connection	120 VAC/20 AMP
Drain Capacity	3 gallons/minute

## Water Purity Conversion Charts

Parts Per Million (PPM)	Grains Per Gallon (GPG)	Hardness Rating
0 - 75	0 – 4.3	Soft
76 - 150	4.4 – 8.7	Moderately Hard
151 - 300	8.8 – 17.5	Hard
Over 300	17.6+	Very Hard

Conductivity (Microsiemens/cm)	Resistivity (MegOhm/cm)
0.056	18
0.063	16
0.071	14
0.083	12
0.100	10
0.133	7.5
0.200	5
0.500	2
1.000	1
1.333	0.75
2.00	0.5
4.00	0.25
10.00	0.1
20.00	0.05
40.00	0.025
80.00	0.013
100.00	0.01
200.00	0.005
500.00	0.002
1000.00	0.001
2000.00	0.0005
5000.00	0.0002
10000.00	0.0001

## Purification Process

The process flow with all its components is illustrated on the flow chart (see pg. 8).

When the system is started in normal operation the inlet valve opens and the reverse osmosis pump starts. The inlet valve controls the water supply into the system. The inlet valve will close, and the pump will stop when the system is shutdown, unplugged, paused, permeate tank is full, or the inlet water pressure drops.

The sediment filter (if applicable) and carbon filter absorb organic chemicals like chlorides, insecticides, pesticides and herbicides from the water and remove particles larger than 5 microns.

The reverse osmosis pump increases the input pressure to the operating pressure for the reverse osmosis process. The pressure is indicated in psi inside the front door on the left gauge.

The reverse osmosis modules remove ~ 98%~ of the waters salt content. Moreover, heavy metal complexes, and organic material with molecular weight exceeding 300 Daltons are rejected. The purified water product is called Permeate; the wastewater including all rejected components is called concentrate. The concentrate is then directed the drain.

The permeate quality is controlled with a Permeate sensor. The Permeate quality is displayed on the front display.

The system is connected to a storage tank with a level sensor. The production of permeate to fill the tank is regulated by the level sensor. When the permeate reaches the maximum level (100%) the production will stop. If the permeate falls below 70% the production of the permeate will be started again and the tank will be filled to the maximum level. If the permeate level falls below 10% distribution pump will automatically shut off and illuminate “Tank Empty” light to prevent a pump failure.

## System Features

This water purification system is designed to produce Permeate out of drinking water from public supply. It unifies purification technologies with Reverse- Osmosis according to the latest developments. The system is connected to a tank with level control measurement.

The production rate of permeate has reduced salt content of 98-99%. Water quality and tank filling is displayed on the systems screen.

The system runs in the following modes:

**RO RUNNING Mode:** Permeate water production and tank filling

```
RO Running
Permeate Cond    0ãS
Permeate Temp  2.6BC
RO Runtime 00000 HRS
```

**TANK FULL Mode:** Production is stopped, and the system is waiting for new water demand.

```
Tank Full
Permeate Cond    0ãS
(From last run)
RO Runtime 00000 HRS
```

**TANK FULL DRAW DOWN Mode:** Production is stopped, and the system is waiting for new water demand.

```
Tank Full--Draw Down
Permeate Cond    0ãS
(From last run)
RO Runtime 00000 HRS
```

**POWER OFF Mode:** System has been turned off.

```
Power Off
```

All components of the water systems cabinet are assembled in an aluminum housing. The front door can easily be opened for the access of the modules. The rear panel can be accessed by removing four screws.

# Flow Chart

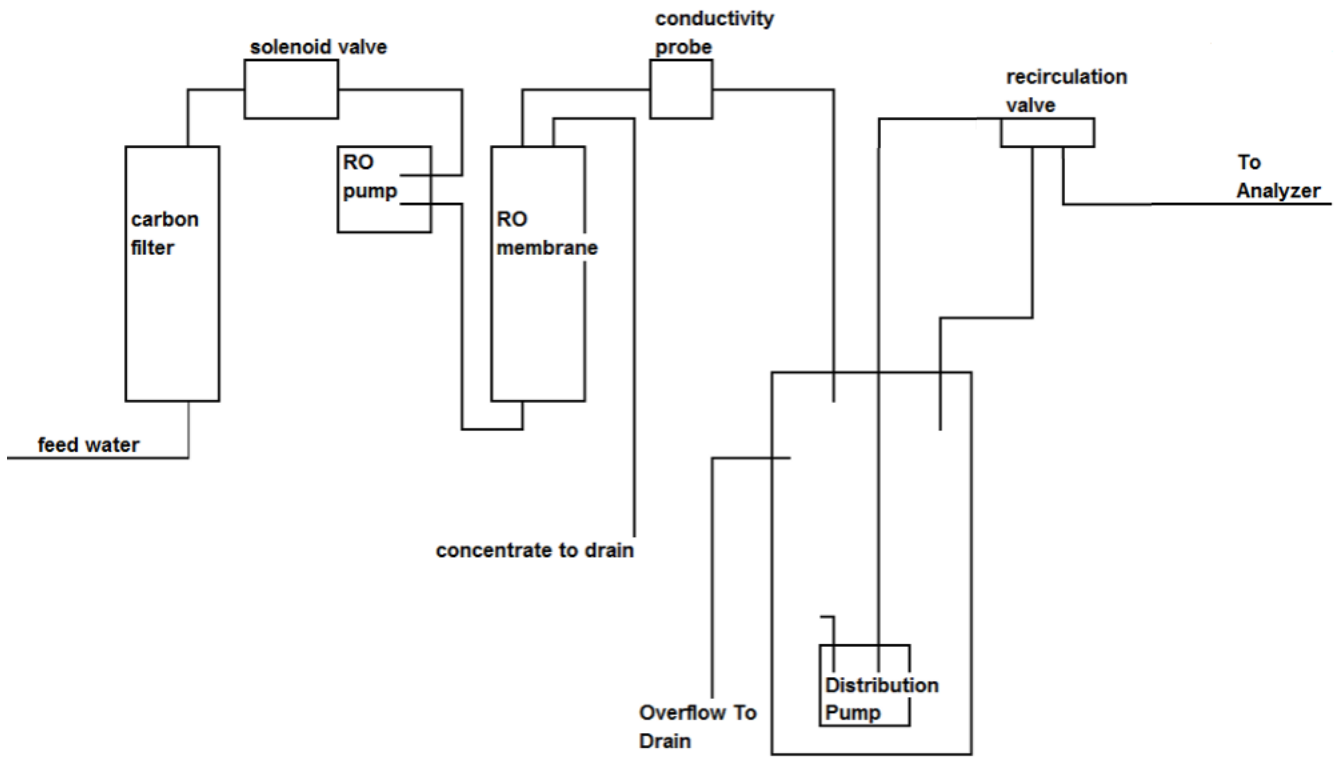

## How to Change Carbon Filter

1. Turn off production switch.
2. Turn off supply water valve.
3. Push red button on top of blue filter housing to relieve pressure.
4. Remove filter housing by turning filter wrench to the left.
5. Pull out filter and replace with new filter.
6. Install filter housing by turning housing by hand until tight. (do not use wrench to tighten)
7. Turn on supply water valve and check for leaks.
8. Turn on production switch.



## Recommended Filter & Membrane Replacement Schedule

FILTER	FREQUENCY (Approx)
Carbon Filter	Change when filter looks brown or when the top Screen says “Low Pressure”
RO Membrane	1-5 Years GWT Replaces this during yearly recertification.

\*Replacement frequency depends on feed water quality and pure water usage.

## Making a connection with Push-Fit Fittings

John Guest fittings are used throughout the system.

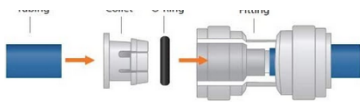

### Step 1 – Cut Tubing

Cut the tube square ensuring it is free of score marks. Avoid damage to the internal O-ring by removing burrs and sharp edges on the tubing. Inside the fitting are stainless steel grippers that grab the tubing.

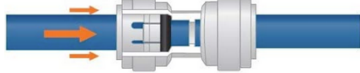

### Step 2 – Assemble the Connection

Push the pipe into the fitting to the tube stop. The collet has stainless steel grippers that hold the pipe firmly in position. The O-ring provides a permanent leak proof seal. Simply pull on the tube to check it is secure.

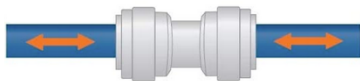

### Step 3 – Disconnect

Depressurize the line before removing the tube. Push in the collet (ring closest to tube) squarely against the face of the fitting. The tube can be removed when the collet is pushed in. The fitting can be re-used.

# Daily Checklist

Month \_\_\_\_\_ Year \_\_\_\_\_

Serial # \_\_\_\_\_

\*Please contact General Water Technologies 801-294-2426 with any questions.

Date	Permeate, $\mu\text{S}/\text{cm}$ Range 0.0 - 50.0	Runtime	<u>Color of Carbon Filters</u> (Change at dark brown or Low Pressure message)			<u>CLS Signature</u>
1			Left	Right	Changed?	
2			Left	Right	Changed?	
3			Left	Right	Changed?	
4			Left	Right	Changed?	
5			Left	Right	Changed?	
6			Left	Right	Changed?	
7			Left	Right	Changed?	
8			Left	Right	Changed?	
9			Left	Right	Changed?	
10			Left	Right	Changed?	
11			Left	Right	Changed?	
12			Left	Right	Changed?	
13			Left	Right	Changed?	
14			Left	Right	Changed?	
15			Left	Right	Changed?	
16			Left	Right	Changed?	
17			Left	Right	Changed?	
18			Left	Right	Changed?	
19			Left	Right	Changed?	
20			Left	Right	Changed?	
21			Left	Right	Changed?	
22			Left	Right	Changed?	
23			Left	Right	Changed?	
24			Left	Right	Changed?	
25			Left	Right	Changed?	
26			Left	Right	Changed?	
27			Left	Right	Changed?	
28			Left	Right	Changed?	
29			Left	Right	Changed?	
30			Left	Right	Changed?	
31			Left	Right	Changed?	