



SINCE 1989



Präzise . Schnell . Innovativ

WEMARO

Experte für Zerspanungswerkzeuge

WEMARO hat sich auf die Entwicklung, Herstellung und den Vertrieb von Zerspanungswerkzeugen zur Bearbeitung von Aluminium, Kunststoff, Stahl und Verbundwerkstoff spezialisiert.

Seit 1989 fräsen, bohren und sägen unsere hochpräzisen Werkzeuge weltweit Profile, Platten und Vollmaterial. Schlanke Prozesse und eine flache Hierarchie ermöglichen es uns, schnell auf die Wünsche und Herausforderungen unserer Kunden zu reagieren. Durch diese enge Zusammenarbeit ist es uns möglich, immer wieder neue und innovative Werkzeuge zu entwickeln.

Unsere Wurzeln liegen in der Fenster- & Türenindustrie, sowie auch dem Fassaden- und Metallbau. Hier werden unsere Produkte, wie z. B. Sägeblätter, Einzahnfräser oder Olivenbohrer, überwiegend bei der Zerspanung von Kunststoff-, Stahl- und Aluminium-Profilen eingesetzt.

Mit Vertretungen in über 50 Ländern sind unsere Produkte auf der ganzen Welt zu finden.

About us

Expert for cutting tools

WEMARO specialises in the development, manufacture and distribution of cutting tools for machining aluminium, plastic, steel and composite materials.

Since 1989, our high-precision tools have been milling, drilling and sawing profiles, sheets and solid material worldwide. Lean processes and a flat hierarchy enable us to react quickly to the wishes and challenges of our customers. This close cooperation enables us to develop new and innovative tools continuously.

Our roots lie in the window & door industry as well as metal construction and curtain wall. Here, our products, such as circular saw blades, single flute cutters or drills, are mainly used in the machining of plastic, steel and aluminium profiles.

With representatives in over 50 countries, our products can be found all over the world.

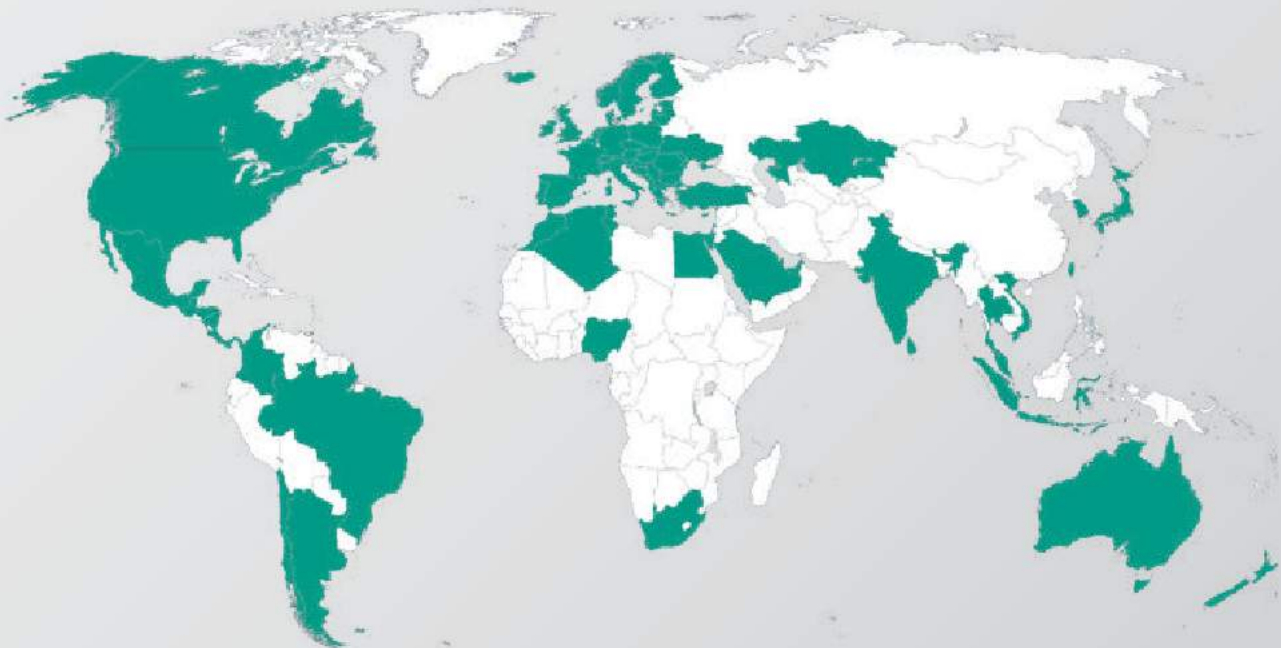



#fräsen

3 - 27

#mill

#bohren

28 - 43

#drill

#alucobond

44 - 45

#alucobond

#sägen

46 - 56

#saw

#kühlen

58 - 60

#cool

#kleben

61

#glue

#spannen

62 - 66

#clamp

#verputzen

70

#welding clean

#schneiden

71

#cut

#einrollen

72

#gasket

#schrauben

73 - 76

#screw

#handwerken

77 - 80

#craft

#verschweißen

81 - 84

#weld

#ersetzen

86 - 87

#replace





Partner seit 1990

**THORWESTEN**
MASCHINENBAU



WEMARO[®]

SINCE 1989

zum Fräsen und Bohren von Profilen aus Aluminium, Kunststoff und NE-Metallen

- verwendbar auf allen Kopierfräsen, Wasserschlitzfräsen und Bearbeitungszentren: AFS, BJM, elumatec, Emmegi, FOM, Haffner, KABAN, Kombimatec, MLA, Pertici, Pressta-Eisele, Rapid, Rotox, Schirmer, Striffler, TEKNA, Thorwesten, Wegoma, etc.
- Drehzahlbereich ca. 8.000 - 20.000 UpM
- bei Aluminiumbearbeitung ist auf direkte und ausreichende Kühlung zu achten!

Single flute cutters HSS-E

for slotting and drilling in Aluminium- and UPVC-profiles

- used on copyrouters, drainage slot routers and CNC-machining-centres: AFS, BJM, elumatec, Emmegi, FOM, Haffner, KABAN, Kombimatec, MLA, Pertici, Pressta-Eisele, Rapid, Rotox, Schirmer, Striffler, TEKNA, Thorwesten, Wegoma, etc.
- speed approx. 8.000 - 20.000 rpm
- direct and adequate cooling-spray is particularly important for aluminium working!

Art.-Nr.	A	B	D	E
060 008 003	3	12	60	8
060 006 004	4	12	60	6
060 008 004	4	12	60	8
060 008 204	4	20	60	8
080 008 004	4	12	80	8
080 008 254	4	25	80	8
010 008 254	4	25	100	8
010 008 124	4	12	100	8
011 008 004	4	40	100	8
011 008 204	4	20	120	8
060 006 005	5	12	60	6
060 008 005	5	12	60	8
060 008 185	5	18	60	8
070 008 255	5	25	70	8
080 008 255	5	25	80	8
080 008 355	5	35	80	8
090 008 255	5	25	90	8
090 008 355	5	35	90	8
010 008 145	5	14	100	8
011 008 025	5	20	100	8
011 008 255	5	25	100	8
011 008 305	5	30	100	8
011 008 005	5	40	100	8
011 008 545	5	45	100	8
020 008 005	5	14	120	8
011 008 205	5	40	120	8
060 006 006	6	14	60	6
060 008 006	6	14	60	8
070 008 256	6	25	70	8
080 008 006	6	14	80	8
080 008 256	6	25	80	8
010 008 146	6	14	100	8
011 008 006	6	40	100	8
060 008 007	7	14	60	8
080 008 007	7	14	80	8
080 008 008	8	14	80	8
080 008 258	8	25	80	8
080 008 408	8	40	80	8
010 008 008	8	14	100	8
010 008 258	8	25	100	8
011 008 008	8	40	100	8

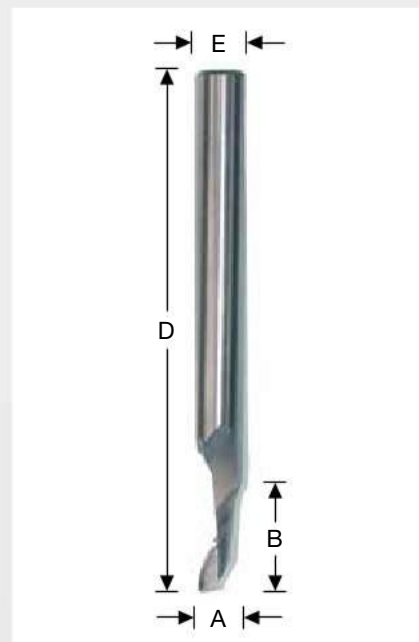

Art.-Nr.	A	B	D	E
020 008 008	8	14	120	8
020 008 258	8	25	120	8
020 008 408	8	40	120	8
080 008 009	9	14	80	8
011 008 009	9	40	100	8
080 008 010	10	14	80	8
010 008 140	10	14	100	8
010 008 010	10	22	100	8
080 010 010	10	14	80	10
020 010 010	10	14	120	10
080 008 011	11	14	80	8
080 008 012	12	14	80	8
090 008 512	12	50	90	8
010 008 012	12	28	100	8
080 010 012	12	14	80	10



Wussten Sie eigentlich schon,
Did you actually know,

.....dass sich die Standzeiten von HSS-Werkzeugen durch moderne PVD-Beschichtungen erheblich verlängern lassen?
 Wir beraten Sie gerne!

*.....that the life-time of HSS cutting tools can be significantly extended when using modern PVD coatings?
 We are happy to help!*

Unsere Standard-Beschichtungen TiN / CrN / TiCN / DLC... bitte umblättern!

Our standard coatings TiN / CrN / TiCN / DLC... please turn the page!

Ein Zahnfräser HSS-E - Hals freigeschliffen

91001

zum Fräsen und Bohren von Profilen aus Aluminium, Kunststoff und NE-Metallen-

- verwendbar auf allen Kopierfräsen, Wasserschlitzfräsen und Bearbeitungszentren: AFS, BJM, elumatec, Emmegi, FOM, Haffner, KABAN, Kombimatec, MLA, Pertici, Pressta-Eisele, Rapid, Rotox, Schirmer, Striffler, TEKNA, Thorwesten, Wegoma, etc.
- Drehzahlbereich ca. 8.000 - 20.000 UpM
- bei Aluminiumbearbeitung ist auf direkte und ausreichende Kühlung zu achten!

Single flute cutters HSS-E - stepped shank -

for slotting and drilling in Aluminium- and UPVC-profiles

- used on copyrouters, drainage slot routers and CNC-machining-centres: AFS, BJM, elumatec, Emmegi, FOM, Haffner, KABAN, Kombimatec, MLA, Pertici, Pressta-Eisele, Rapid, Rotox, Schirmer, Striffler, TEKNA, Thorwesten, Wegoma, etc.
- speed approx. 8.000 - 20.000 rpm
- direct and adequate cooling-spray is particularly important for aluminium working!

Art.-Nr.	A	B	C	D	E
080 108 004	4	18	35	80	8
090 108 004	4	16	45	90	8
080 106 005	5	18	35	80	6
080 108 005	5	18	35	80	8
090 108 005	5	16	45	90	8
090 108 155	5	16	55	90	8
010 108 005	5	18	35	100	8
010 108 255	5	25	55	100	8
020 108 005	5	14	35	120	8
020 108 175	5	14	75	120	8
020 108 145	5	20	45	120	8
025 108 005	5	14	65	125	8
080 108 006	6	14	35	80	8
090 108 006	6	16	45	90	8
010 108 006	6	18	35	100	8
080 108 007	7	14	45	80	8
080 108 008	8	14	54	80	8
010 108 008	8	14	68	100	8
010 108 308	8	30	70	100	8
020 108 008	8	14	90	120	8
020 108 308	8	30	70	120	8
085 110 010	10	14	65	85	10
090 010 451	10	25	45	90	10
096 110 010	10	14	75	96	10
010 110 010	10	30	70	100	10
020 110 010	10	14	95	120	10
020 110 310	10	30	70	120	10

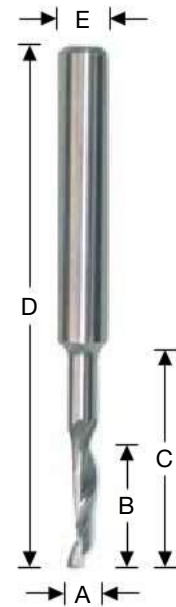

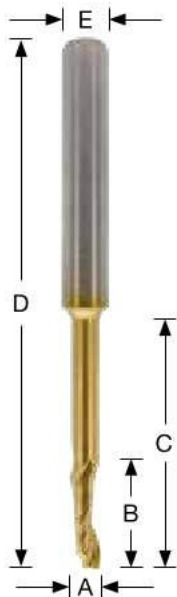

Einzahnfräser HSS-E

91003

TiN-beschichtet

- für längere Standzeit bei PVC-Bearbeitung

Single flute cutters HSS-E

TiN-coated

- for longer durability in UPVC-profiles

Art.-Nr.	A	B	C	D	E
060 018 004	4	12		60	8
060 018 005	5	12		60	8
060 018 185	5	18		60	8
080 118 005	5	18	35	80	8
090 118 005	5	16	45	90	8
011 018 255	5	25		100	8
011 018 005	5	40		100	8
060 018 006	6	14		60	8
080 018 008	8	14		80	8
080 118 008	8	14	54	80	8
020 018 008	8	14		120	8

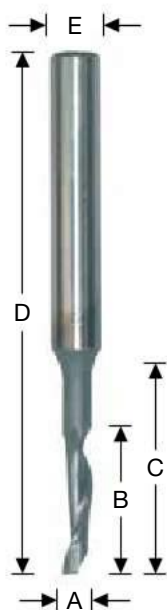

Einzahnfräser HSS-E

91004

CrN-beschichtet

- für längere Standzeit bei Aluminium-Bearbeitung

Single flute cutters HSS-E

CrN-coated

- for longer durability in Aluminium-profiles

Art.-Nr.	A	B	C	D	E
060 028 003	3	12		60	8
060 028 004	4	12		60	8
060 028 005	5	12		60	8
060 028 185	5	18		60	8
080 128 005	5	18	35	80	8
080 028 355	5	35		80	8
060 028 006	6	14		60	8
080 128 006	6	18	35	80	8
060 028 007	7	14		60	8
080 028 008	8	14		80	8
080 128 008	8	14	54	80	8
080 028 258	8	25		80	8
090 028 451	10	25	45	90	10

Einzahnfräser HSS-E

91005

TiCN-beschichtet

- für längere Standzeit bei Aluminium- und PVC-Bearbeitung

Single flute cutters HSS-E

TiCN-coated

- for longer durability in Aluminium- and UPVC-profiles

Art.-Nr.	A	B	C	D	E
060 048 005	5	12		60	8
060 048 006	6	14		60	8
060 048 007	7	14		60	8
080 048 008	8	14		80	8
080 148 005	5	18	35	80	8
080 148 008	8	14	54	80	8

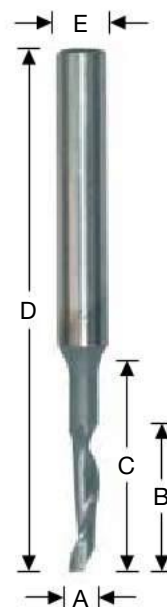

Wasserschlitzfräser HSS-E

91010

Zweischneidig, spiralig

- für Wasserschlitzfräsen
- elumatec, Haffner, Kombimatec, MLA, ROTOX, Striffler, Wegoma, etc.
- für Aluminium-Bearbeitung

Waterslot cutters HSS-E

Two flutes, spiral

- for elumatec, Haffner, Kombimatec, MLA, ROTOX, Striffler, Wegoma, etc.
- for aluminium-working

Art.-Nr.	A	B	D	E
012 008 905	5	30	90	8
012 008 005	5	40	100	8

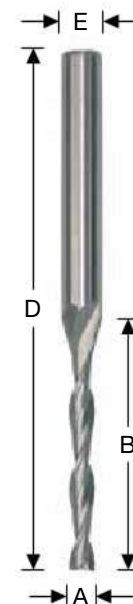

Wasserschlitzfräser HSS-E

91011

Zweischneidig, spiralig mit Bohrspitze

- für Wasserschlitzfräsen
- elumatec, Haffner, Kombimatec, MLA, ROTOX, Striffler, Wegoma, etc.
- für PVC-Bearbeitung

Waterslot cutters HSS-E

Two flutes, spiral with drill point

- for elumatec, Haffner, Kombimatec, MLA, ROTOX, Striffler, Wegoma, etc.
- for UPVC-working

Art.-Nr.	A	B	D	E
014 006 005	5	45	100	6
014 008 305	5	30	90	8
014 008 495	5	40	90	8
014 008 405	5	40	100	8

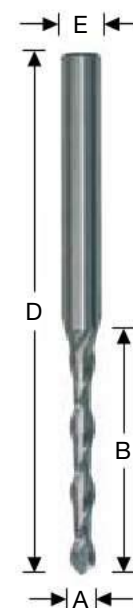

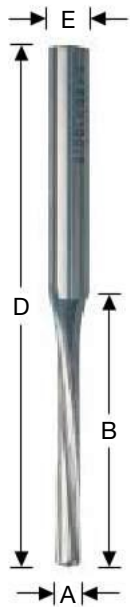

Bohrnutenfräser HSS-E

91012

Zweischneidig, spiralg, leichter Drall, Rechtslauf / Linksdrahl

- für Aluminium- und PVC-Profilbearbeitung.
- Spezialausführung für höchste Beanspruchung.
- für elumatec, Haffner, Kombimatec, MLA, ROTOX, Pertici, etc.

Milling cutters HSS-E

Two flutes, spiral, slow spiral, RH cut / LH spiral

- for aluminium- and UPVC-routing and waterslotting.
- Specially designed to give added strength and prevent breakages.
- for elumatec, Haffner, Kombimatec, MLA, ROTOX, Pertici, etc.

Art.-Nr.	A	B	D	E
015 008 440	4	40	100	8
015 008 535	5	35	80	8
015 008 540	5	40	100	8
015 008 545	5	45	120	8

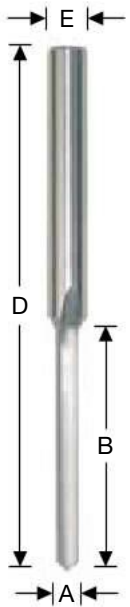

Wasserschlitzfräser HSS-E

91021

Einschneidig, gerade, mit Bohrspitze

- für Wasserschlitzfräsen
- für PVC-Bearbeitung
- für elumatec, Haffner, Kombimatec, MLA, ROTOX, Striffler, Wegoma, etc.

Waterslot cutters HSS-E

Single flute, straight, with drill point

- for UPVC-working
- for elumatec, Haffner, Kombimatec, MLA, ROTOX, Striffler, Wegoma, etc.

Art.-Nr.	A	B	C	D	E
013 008 254	4	25		100	8
013 008 705	5	30		70	8
013 008 305	5	35		80	8
013 008 485	5	45		90	8
013 008 355	5	35		100	8
013 008 455	5	45		100	8
013 008 555	5	55		100	8
013 120 545	5	45		120	8
013 008 306	6	30		100	8
013 008 456	6	45		100	8
013 108 308	8	30	62	100	8

Spezialfräser für Brandschutztüren, Edelstahl, JANSEN-Profile, Schüco auf Seite 44

Special milling bits for fire-proof doors, stainless steel, JANSEN-profiles, Schüco on page 44

Einzahnfräser HSS-E

91023

Spezialausführung für Stahlprofile

- beschichtet für längere Standzeit

- verwendbar auf allen Kopierfräsen und Bearbeitungszentren:
elumatec, Emmegi, Haffner, MLA, Pertici, Pressta-Eisele, Rapid, Rotox, Striffler, TEKNA, Wegoma, etc.
- Drehzahlbereich ca. 6.000 - 12.000 UpM
- auf direkte und ausreichende Kühlung ist zu achten!

Single flute cutters HSS-E

Special cutters for steel cutting

- coated for longer durability

- used on copyrouters and CNC-machining-centres:
elumatec, Emmegi, Haffner, MLA, Pertici, Pressta-Eisele, Rapid, Rotox, Striffler, TEKNA, Wegoma, etc.
- speed approx. 6.000 - 12.000 rpm
- direct and adequate cooling-spray is particularly important for steel working!

Art.-Nr.	A	B	D	E
160 038 005	5	12	60	8
180 038 008	8	14	80	8

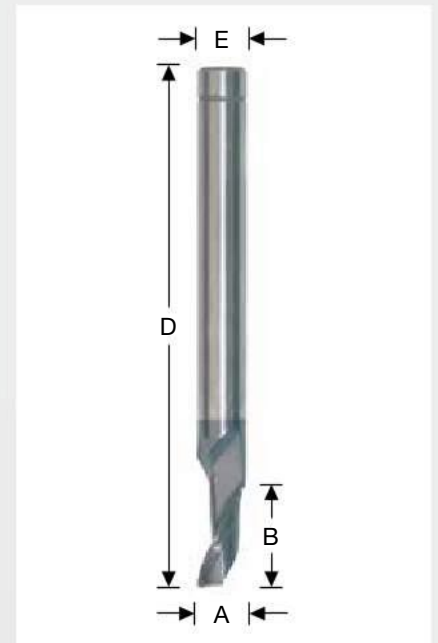

Schaftfräser VHM

91131

Zweischneidig, spiralig,

für Stahlbearbeitung mit Spezialbeschichtung „SteelMaxx“

- verwendbar auf Kopierfräsen und Bearbeitungszentren, z.B. Schüco, Mecal, etc.

Milling cutters - solid carbide -

Two flutes, spiral,

for steel working - special coated „SteelMaxx“

- for copy routers and high speed router machines, as Schüco, Mecal, etc.

Art.-Nr.	A	B	D	E
182 766 004	4	10	57	6
182 766 005	5	10	57	6
182 766 006	6	10	57	6
182 768 008	8	16	63	8
182 761 010	10	19	72	10

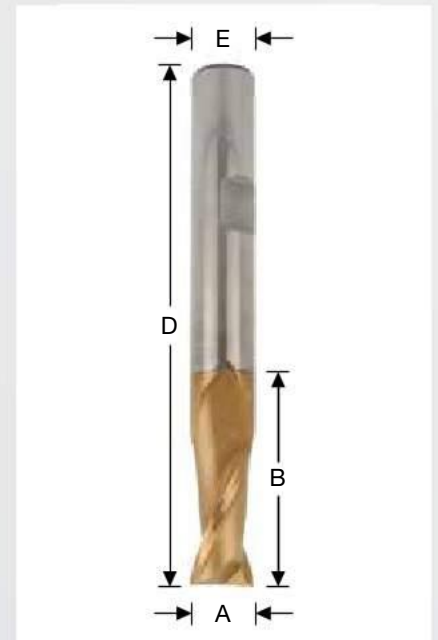

Doppelfräser VHM

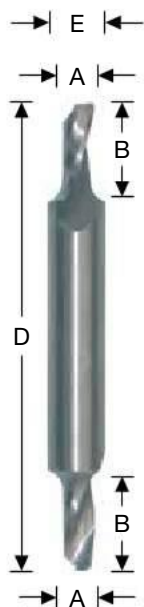

Einschneidig, spiralig

Spezialausführung für Stahlprofile

- verwendbar auf allen Kopierfräsen und Bearbeitungszentren: elumatec, Emmegi, Haffner, MLA, Pertici, Pressta-Eisele, Rapid, Rotox, Striffler, TEKNA, Wegoma, etc.
- Drehzahlbereich ca. 6.000 - 12.000 UpM
- zur Bearbeitung von Stahlprofilen auf Kopierfräsen
- bei Stahlbearbeitung ist auf direkte und ausreichende Kühlung zu achten!

Double-ended single flute cutters - solid carbide -

Single flute, spiral

Special cutters for steel cutting

- used on copyrouters and CNC-machining-centres: elumatec, Emmegi, Haffner, MLA, Pertici, Pressta-Eisele, Rapid, Rotox, Striffler, TEKNA, Wegoma, etc.
- speed approx. 6.000 - 12.000 rpm
- for working steel profiles on copy-routers
- direct and adequate cooling-spray is particularly important for steel working!

Art.-Nr.	A	B	D	E
065 708 005	5	11	65	8



Wussten Sie eigentlich schon,
Did you actually know,

.....dass die Lebensdauer Ihrer Zerspanungswerkzeuge durch die korrekte Auswahl des geeigneten Kühlschmiermittels erheblich verlängert werden kann?

Ab Seite 58 finden Sie die optimal abgestimmten Produkte.

.....that the lifespan of your cutting tools can be extended considerably by choosing the correct coolant liquid?

You can find optimized products from page 58.

Bohrnutenfräser HSS-E

91025

Zweischneidig, spiralgig

- mit Spezial-Stirnanschliff für leichtes Eintauchen
- für Aluminium und Kunststoff

Milling cutters HSS-E

Two flutes, spiral

- special grinded for easy drilling
- for aluminium and UPVC

Art.-Nr.	A	B	D	E	Bild / pic
082 008 004	4	12	60	8	1
082 008 005	5	12	60	8	1
082 008 006	6	14	60	8	1
082 008 008	8	14	80	8	1
082 008 208	8	30	100	8	2
082 008 308	8	40	100	8	2
082 008 010	10	14	80	8	1
082 010 010	10	45	95	10	2
012 010 010	10	25	120	10	2
082 008 012	12	14	80	8	1
012 012 012	12	30	120	12	2
082 012 112	12	53	110	12	2
082 012 013	13	26	83	12	1
082 012 114	14	53	110	12	2
082 016 016	16	63	123	16	2
082 016 018	18	63	123	16	2
082 020 020	20	75	141	20	2

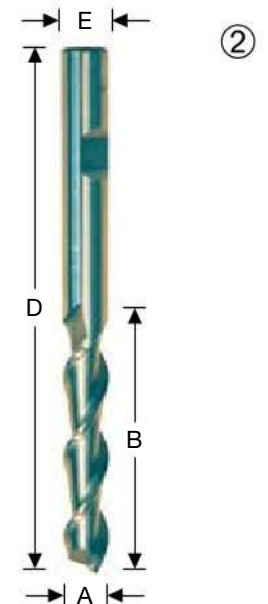
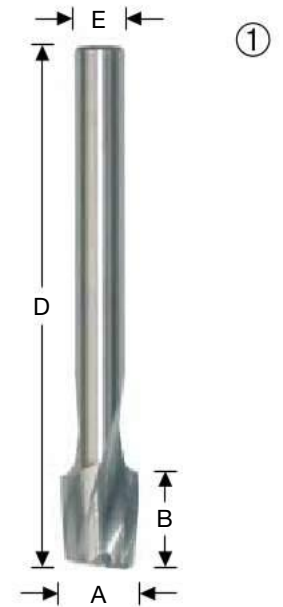

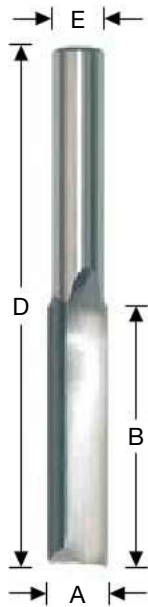

Bohrnutenfräser HSS-E

91026

Zweischneidig, gerade genutet

- für PVC-Bearbeitung auf Kopierfräsen (z.B. Schlosskästen)

Slot milling cutters HSS-E

Two flutes, straight

- for UPVC-working, used on copyrouters

Art.-Nr.	A	B	D	E	
075 010 008	8	30	75	10	
075 008 010	10	40	75	8	
097 010 010	10	40	97	10	
075 008 012	12	40	75	8	
075 010 012	12	40	75	10	
097 010 012	12	48	97	10	
097 010 014	14	48	97	10	
097 010 016	16	48	97	10	
097 010 018	18	48	97	10	
097 710 010	10	40	97	10	HM-best / Carb. tip.
097 710 012	12	40	97	10	HM-best / Carb. tip.
097 710 014	14	40	97	10	HM-best / Carb. tip.
090 778 016	16	30	90	8	HM-best / Carb. tip.
097 710 016	16	45	97	10	HM-best / Carb. tip.

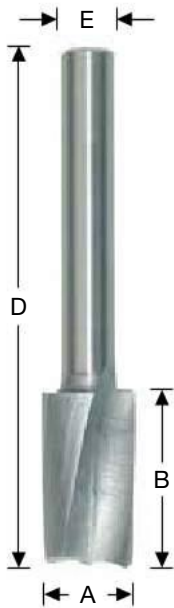

Schlosskastenfräser HSS-E

91027

Zweischneidig, spiralig

- für PVC-Bearbeitung

Slot milling cutters HSS-E

Two flutes, spiral

- for UPVC-working

Art.-Nr.	A	B	D	E	
082 008 312	12	25	75	8	
082 008 412	12	25	85	8	
082 008 512	12	50	90	8	
082 008 314	14	25	75	8	

Fräsbohrer HSS-E - elumatec -

91029

passend zu elumatec KF 78/60

Routing drills HSS-E - elumatec -

for elumatec KF 78/60

Art.-Nr.	A	B	D	E
078 365 100	10	90	148	10
078 365 101	10	72	126	10

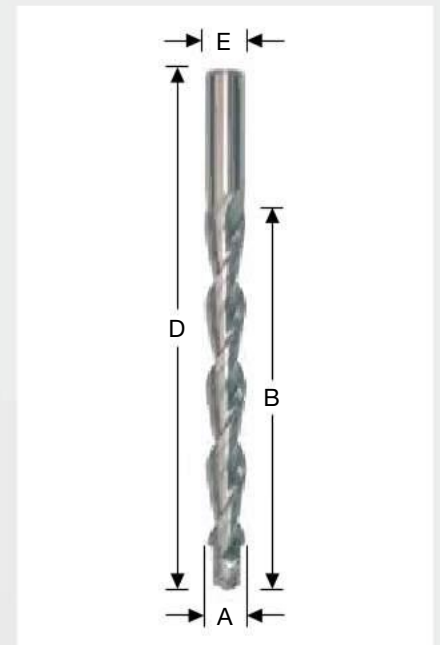

Schafffräser HSS-E - elumatec -

91030

Zweischneidig, spiralig

- passend zu elumatec KF 178

- R = Rechtslauf - L = Linkslauf

Milling cutters HSS-E - elumatec -

Two flutes, spiral

- for elumatec KF 178

- R = RH-rotation - L = LH-rotation

Art.-Nr.	A	B	C	D	E	
178 366 010	10	22	60	100	10	R
178 366 110	10	22	40	100	10	L
178 366 210	10	22	70	120	10	R

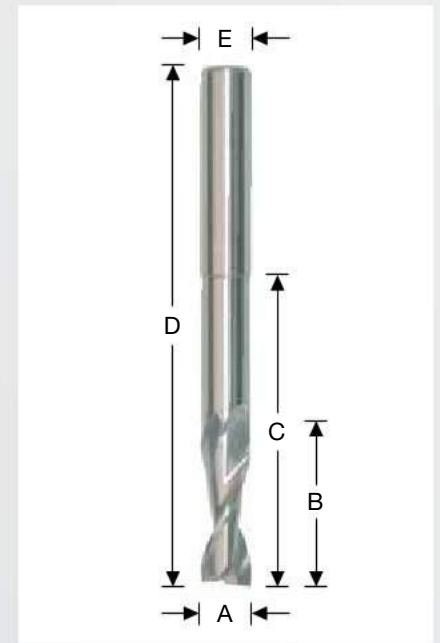

Wussten Sie eigentlich schon,
Did you actually know,

.....dass wir unsere Werkzeuge auch nach Kundenwunsch / Eigenmarke oder zusätzlichen Daten / Artikelnummern beschriften können?
Ein kurzes Info-Video finden Sie mit diesem QR Code.
Wir informieren Sie gerne!



.....that we can offer special laser marking for our tools on customer request / brand or additional data / part numbers etc.?
A short video is available with this QR code.
We will be happy to inform you!

Innenfalz- / Dichtungsnutfräser HSS-E

für Schweißraupen-Verputzmaschinen

- z.B. elumatec, Stürtz, KMW, Urban, Rotox, Wegoma, etc.

- TiN-Beschichtung auf Anfrage

Router cutters & gasket groove cutters HSS-E

for corner cleaning machines

- as elumatec, Stürtz, KMW, Urban, Rotox, Wegoma, etc.

- TiN-coating on demand

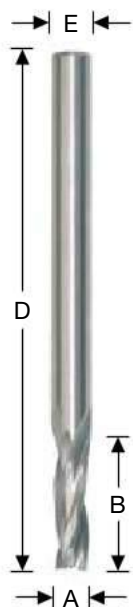

Art.-Nr.	A	B	D	E	Z/T	
068 006 005	5	24	68	6	2	
068 006 006	6	24	68	6	2	
016 706 006	6	20	120	6	2	VHM / TC
016 178 006	6	25	100	8	2	VHM / TC
016 128 206	6	20	120	8	2	
016 128 306	6	20	120	8	3	
055 006 065	6,5	16	55	6	2	
066 006 065	6,5	16	66	6	2	
075 006 065	6,5	16	75	6	2	
016 108 207	7	20	100	8	2	
016 108 307	7	20	100	8	3	
016 178 007	7	25	100	8	2	VHM / TC
016 128 207	7	20	120	8	2	
016 128 307	7	20	120	8	3	
055 006 075	7,5	16	55	6	2	
066 006 075	7,5	16	66	6	2	
075 006 075	7,5	16	75	6	2	
095 006 075	7,5	19	95	6	2	
016 108 308	8	20	100	8	3	
016 128 208	8	20	120	8	2	
016 128 308	8	20	120	8	3	
016 178 148	8	20	140	8	2	VHM / TC

Bohrnutenfräser HSS-E

91033

für Bearbeitungszentren elumatec, Stürtz, Thorwesten, Wegoma, etc.
- auch beschichtet lieferbar

Slot milling cutters HSS-E

for CNC-machines as elumatec, Stürtz, Thorwesten, Wegoma, etc.
- also available with coating

Art.-Nr.	A	B	D	E	Z/T	Bild/pic.
084 010 010	10	45	95	10	4	2
084 010 910	10	45	95	10	4	1
084 012 012	12	53	110	12	4	2
084 012 212	12	53	110	12	3	2
084 012 112	12	53	110	12	4	3
084 012 312	12	53	110	12	3	3
084 012 912	12	53	110	12	4	1
084 012 013	13	53	110	12	4	2
084 012 214	14	53	110	12	3	2
084 012 914	14	53	110	12	4	1
084 012 412	12	85	130	12	4	2
084 012 414	14	85	130	12	4	2
084 712 412	12	53	110	12	4	VHM / solid carbide 2

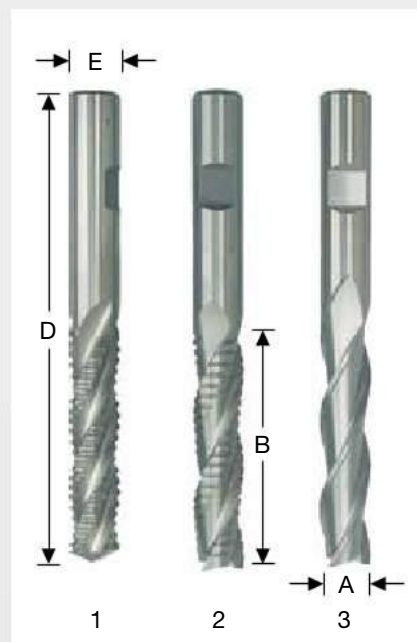

Nutfräser HSS, Innengewinde M10

91034

zur Bearbeitung von PVC-Profilen mit Handmaschinen
- z.B. Rotox, Striffler, STRIMA, etc.

Milling cutters HSS, female thread M10

for working UPVC-profiles with hand-routers
- as Rotox, Striffler, STRIMA, etc.

Art.-Nr.	A	B	C	
052 100 003	3	8	52	
052 100 004	4	12	52	
052 100 005	5	23	52	
052 100 006	6	23	52	
047 100 008	8	26	47	
043 100 010	10	20	43	
043 100 012	12	14,5	43	
043 100 112	12	23	43	
058 100 012	12	38	58	
080 100 012	12	45	80	M12x1
043 100 014	14	21	43	
043 100 016	16	23	43	
043 100 018	18	23	43	
043 700 012	12	14,5	43	HM-best. / Carb.-tip.

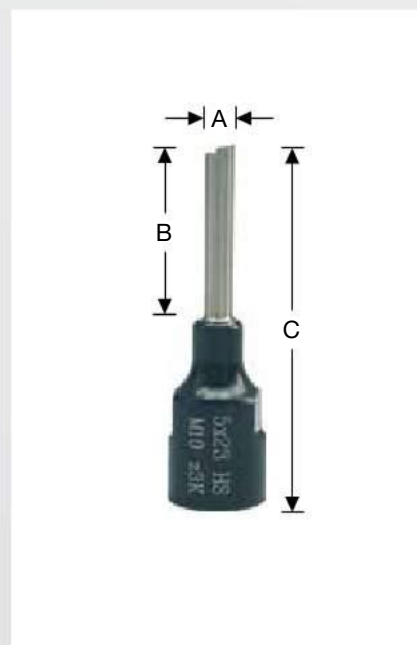

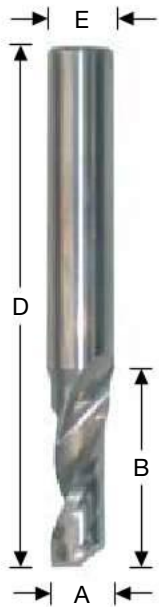

Einzahnfräser VHM

91100

zum Fräsen und Bohren von Profilen aus Aluminium, Kunststoff und NE-Metallen

- verwendbar auf allen Bearbeitungszentren:

BJM, elumatec, Emmegi, FOM, Haffner, Handtmann, HEFI, Italmac, Mecal, MLA, Pertici, Pressta-Eisele, Rapid, Rotox, Schirmer, Schüco, Striffler, TEKNA, Wegoma, etc.

- Drehzahlbereich ca. 8.000 - 30.000 UpM

- zur Bearbeitung von Aluminium- und Kunststoffprofilen

- bei Aluminiumbearbeitung ist auf direkte und ausreichende Kühlung zu achten!

Single flute cutters - solid carbide -

for slotting and drilling in Aluminium- and UPVC-profiles

- used on CNC-machining-centres:

BJM, elumatec, Emmegi, FOM, Haffner, Handtmann, HEFI, Italmac, Mecal, MLA, Pertici, Pressta-Eisele, Rapid, Rotox, Schirmer, Schüco, Striffler, TEKNA, Wegoma, etc.

- speed approx. 8.000 - 30.000 rpm

- for working of aluminium- and UPVC profiles

- direct and adequate cooling-spray is particularly important for aluminium working!

Art.-Nr.	A	B	D	E	
050 706 002	2	10	50	6	
050 703 003	3	12	50	3	
050 706 003	3	12	50	6	
060 708 003	3	12	60	8	
070 706 032	3,2	12	70	6	
050 704 004	4	15	50	4	
070 704 040	4	12	70	4	
060 705 004	4	25	60	5	
060 706 004	4	14	60	6	
070 706 004	4	8	70	6	Schüco*
070 706 040	4	12	70	6	
060 708 004	4	20	60	8	
060 705 005	5	20	60	5	
070 705 050	5	12	70	5	
070 705 005	5	30	70	5	
080 705 005	5	40	80	5	
080 705 045	5	45	80	5	
090 705 005	5	30	90	5	
060 706 005	5	20	60	6	
080 706 005	5	40	80	6	
060 708 005	5	20	60	8	
070 708 005	5	15	70	8	
070 708 305	5	30	70	8	
080 708 005	5	20	80	8	
080 708 305	5	30	80	8	
080 708 045	5	40	80	8	
090 708 205	5	20	90	8	
090 708 005	5	30	90	8	
010 708 005	5	12	100	8	
010 708 025	5	20	100	8	
011 708 005	5	40	100	8	
020 708 005	5	20	120	8	
060 706 006	6	16	60	6	
060 706 026	6	20	60	6	
070 706 060	6	12	70	6	
075 706 006	6	20	75	6	
080 706 036	6	30	80	6	
080 706 006	6	40	80	6	

Art.-Nr.	A	B	D	E
010 706 006	6	12	100	6
010 706 306	6	30	110	6
060 708 006	6	16	60	8
060 708 007	7	18	60	8
060 708 008	8	18	60	8
070 708 080	8	12	70	8
070 708 008	8	25	75	8
080 708 358	8	35	80	8
090 708 008	8	35	90	8
010 708 080	8	16	100	8
010 708 308	8	30	100	8
020 708 008	8	14	120	8
020 708 358	8	35	120	8
150 708 008	8	50	150	8
090 708 510	10	50	90	8
070 710 110	10	22	70	10
070 710 010	10	28	75	10
080 710 310	10	30	80	10
083 710 010	10	45	83	10
090 710 010	10	20	90	10
010 710 710	10	30	100	10
097 710 110	10	40	100	10
010 710 521	10	52	100	10
083 710 012	12	35	83	10
083 710 412	12	45	83	10
070 712 012	12	24	70	12
080 712 012	12	32	80	12
080 712 412	12	42	80	12
090 712 012	12	55	90	12
010 712 712	12	35	100	12
020 712 012	12	40	120	12
083 710 413	13	45	83	10
083 710 014	14	35	83	10
075 714 140	14	26	75	14
090 716 016	16	25	90	16
010 720 020	20	30	100	20

* Schaft mit Spannfläche / shank with WELDON flat



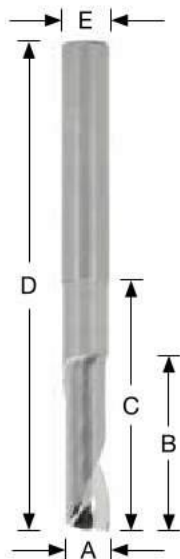

Spezialausführung zur Hochgeschwindigkeitsbearbeitung von Aluminium auf Bearbeitungszentren

- z.B. elumatec, Emmegi, FOM, Handtmann, Rapid, etc.
- höhere Drehzahlen und Vorschübe möglich = Kosten- und Geräuschreduzierung
- bis zu 3-fach höhere Standzeit

Single flute cutters - solid carbide - polished

Special version for high-speed cutting/HSC of aluminium extrusions on CNC-machining centres

- as elumatec, Emmegi, FOM, Handtmann, Rapid, etc.
- more speed and feed
- reduction in noise level
- long life

Art.-Nr.	A	B	C	D	E
140 390 102	2	7		70	8
140 390 103	3	10		70	8
050 903 003	3	12		50	3
060 905 004	4	20		60	5
060 908 004	4	12		60	8
140 390 104	4	10		70	8
080 918 004	4	10	40	80	8
050 904 004	5	15		50	4
060 905 005	5	20		60	5
060 908 005	5	20		60	8
140 390 105	5	16		70	8
080 918 005	5	10	40	80	8
140 391 105	5	20	25	80	8
060 908 006	6	20		60	8
070 906 006	6	16		70	6
140 390 106	6	16		70	8
080 918 006	6	10	40	80	8
140 391 106	6	22	40	80	8
140 390 107	7	16		70	8
140 390 108	8	22		70	8
080 908 008	8	25		80	8
080 918 008	8	12	54	80	8
140 391 108	8	22	40	80	8
140 390 110	10	22		70	10
075 910 010	10	30		75	10
011 918 010	10	12	80	110	10
084 912 012	12	30		84	12

Einzahnfräser VHM – Spanbrecher –

91103

Spezialausführung mit zusätzlicher Spanleitstufe für optimalen Spanauswurf bei Aluminium-Bearbeitung auf Bearbeitungszentren

- höchstmöglicher Vorschub bis 6.000 mm bei optimalem Fräsbild



Single flute cutters - solid carbide – chipbreaker –

Special version with chipbreaker for aluminium extrusions on CNC machining centres

- best possible feed up to 6.000 mm and best cutting result

Art.-Nr.	A	B	C	D	E	Bild/pic.
070 608 004	4	10		70	8	1
070 608 005	5	10		70	8	1
068 610 205	5	15	20	68	10	2
080 618 005	5	18	35	80	8	2
090 618 005	5	18	35	90	8	2
010 618 005	5	18	35	100	8	2
060 606 006	6	16		60	6	1
070 608 006	6	10		70	8	1
080 608 008	8	14		80	8	1
080 608 208	8	20		80	8	1
080 618 208	8	20	50	80	8	2
010 618 208	8	20	70	100	8	2
020 618 208	8	20	80	120	8	2
080 610 010	10	20		80	10	1
080 611 010	10	20	50	80	10	2
010 610 010	10	20	73	100	10	2
020 610 010	10	20	93	120	10	2
010 610 110	10	30		100	10	1
010 611 310	10	30		110	10	1
080 612 012	12	30		80	12	1

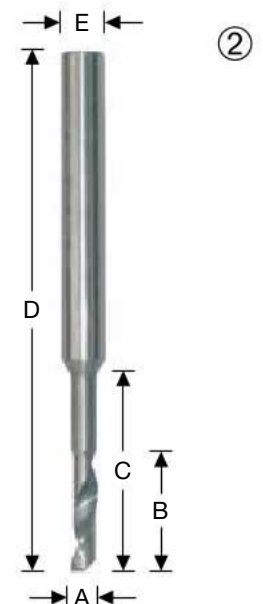
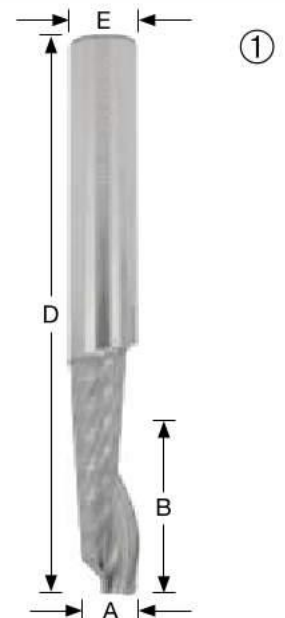

Einzahnfräser VHM – Spiegelschliff - Trockenfräsen –

91104

Spezialausführung zur Hochgeschwindigkeitsbearbeitung auf leistungsfähigen Profil-Bearbeitungszentren

- z. B. bavius, elumatec, Emmegi, Mecal, Schüco, etc.

- DLC Spezialbeschichtung zur Trockenbearbeitung von Al-Legierungen

- Schnittwerttabelle auf Anfrage

Single flute cutters – solid carbide - polished dry cut –

Highspeed cutting HSC for powerful CNC-profile machining centres

- as bavius, elumatec, Emmegi, Mecal, Schüco, etc.

- DLC high-performance coating for dry machining of all common aluminium alloys

- cutting value table upon request

Art.-Nr.	A	B	C	D	E
140 399 001 04	4	10		70	8
140 399 001 05	5	16		70	8
140 399 021 05	5	10	40	80	8
140 399 011 05	5	20	25	80	8
140 399 011 08	8	20	40	80	8

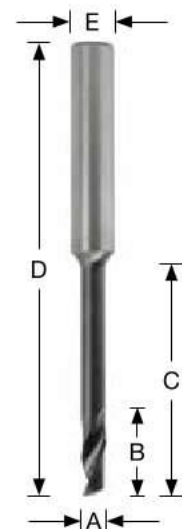

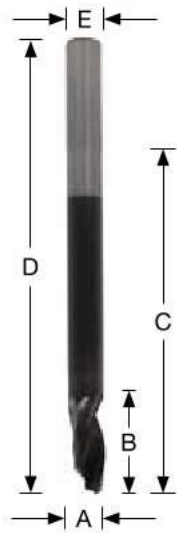

Spezialausführung mit Spanleitstufe für optimalen Spanauswurf

- DLC Spezialbeschichtung zur Trockenbearbeitung von Al-Legierungen
- bestmögliche Standzeit und Vorschubgeschwindigkeit bei gleichzeitig hervorragenden Bearbeitungsergebnissen
- Schnittwertabelle auf Anfrage

Single flute cutters – solid carbide - chipbreaker - dry cut –

Special version with chipbreaker

- DLC high-performance coating for dry machining of all common aluminium alloys
- maximum tool life and feed with excellent results at the same time
- Cutting value table upon request

Art.-Nr.	A	B	C	D	E
070 688 004	4	10	16	70	8
070 688 005	5	10		70	8
080 688 205	5	18	35	80	8
090 688 005	5	18	35	90	8
060 688 006	6	16		60	6
070 688 006	6	10		70	8
080 688 008	8	14		80	8
080 688 218	8	20	50	80	8
080 680 010	10	20		80	10
010 680 010	10	20	73	100	10
020 680 010	10	20	93	120	10
080 688 012	12	30		80	12

bis zu 300% höhere Vorschübe

Hochleistungswerkzeug für wirtschaftlichste Aluminiumzerspanung dank einzigartiger WEMARCO Spannutgeometrie. Optimierte Spanabfuhr ermöglicht extreme Vorschubgeschwindigkeiten!

feed rate up to 300% higher

High-performance tool for economical machining of aluminium thanks to the unique WEMARCO geometry. Optimized chip removal enables extreme feed / speed!

Nicht zu glauben? Schauen Sie sich ein Bearbeitungsvideo auf YouTube an
Unbelievable? Watch our video on YouTube



Einzahnfräser VHM - Hals freigeschliffen -

91105

zum Fräsen und Bohren von Profilen aus Aluminium, Kunststoff und NE-Metallen

- verwendbar auf allen Bearbeitungszentren:

BJM, elumatec, Emmegi, FOM, Haffner, Handtmann, HEFI, Italmac, Mecal, MLA, Pertici, Pressta-Eisele, Rapid, Rotox, Schirmer, Schüco, Striffler, TEKNA, Wegoma, etc.

- Drehzahlbereich ca. 8.000 - 30.000 UpM

- zur Bearbeitung von Aluminium- und Kunststoffprofilen

- bei Aluminiumbearbeitung ist auf direkte und ausreichende Kühlung zu achten!

Single flute cutters - solid carbide - stepped shank

for slotting and drilling in Aluminium- and UPVC-profiles

- used on CNC-machining-centres:

BJM, elumatec, Emmegi, FOM, Haffner, Handtmann, HEFI, Italmac, Mecal, MLA, Pertici, Pressta-Eisele, Rapid, Rotox, Schirmer, Schüco, Striffler, TEKNA, Wegoma, etc.

- speed approx. 8.000 - 30.000 rpm

- for working of aluminium- and UPVC profiles

- direct and adequate cooling-spray is particularly important for aluminium working!

Art.-Nr.	A	B	C	D	E	
057 716 003	3	7	10	57	6	Schüco*
070 714 032	3,2	12	40	70	4	
070 716 004	4	8	13	70	6	Schüco*
077 716 004	4	10	40	77	6	Schüco*
080 718 004	4	15	35	80	8	
077 716 005	5	8	40	77	6	Schüco*
080 718 005	5	16	35	80	8	
090 718 005	5	20	45	90	8	
090 718 355	5	35	55	90	8	
010 718 305	5	30	50	100	8	
010 718 405	5	40	50	100	8	
010 718 355	5	30	60	100	8	
011 718 305	5	30	62	110	8	
025 718 005	5	15	45	125	8	
077 716 006	6	10	40	77	6	Schüco*
080 718 006	6	20	35	80	8	
090 718 006	6	20	30	90	8	
070 718 007	7	18	45	70	8	
070 718 008	8	16	40	70	8	
080 718 008	8	10	40	80	8	Schüco*
090 718 358	8	35	50	90	8	
010 718 008	8	16	70	100	8	
010 718 258	8	25	60	100	8	
020 718 008	8	35	80	120	8	
010 718 108	8	10	40	100	8	Schüco*
011 718 108	8	10	60	100	8	Schüco*
138 712 010	10	12	105	138	12	Schüco*
011 710 010	10	15	65	110	10	Schüco*
011 710 126	10	15	82	126	10	Schüco*
010 711 010	10	20	70	100	10	
010 712 012	12	20	70	100	12	
010 716 016	16	30	50	100	16	

* Schaft mit Spannfläche / shank with WELDON flat

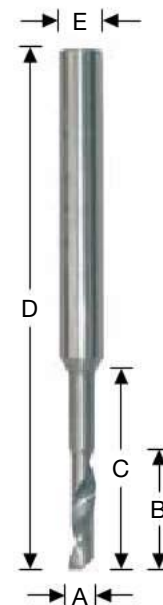

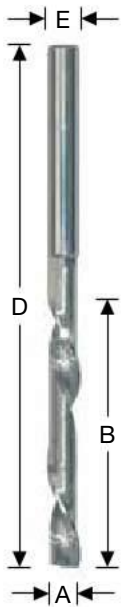

Einzahnfräser VHM

91106

- Spezialausführung:
- Linksdrall - Spanauswurf nach unten
- zur PVC-Bearbeitung

Single flute cutters - solid carbide -

- Special version:
- RH/cut - LH/spiral - downward chip clearance
- for UPVC-working

Art.-Nr.	A	B	D	E
038 703 203	3	10	38	3
040 704 204	4	14	60	4
060 705 205	5	20	60	5
060 705 255	5	25	60	5
080 705 205	5	40	80	5
090 705 205	5	40	90	5
080 705 250	5	50	80	5
010 705 205	5	70	100	5
060 706 206	6	20	60	6
080 706 206	6	40	80	6
075 708 208	8	20	75	8
090 708 208	8	40	90	8
075 710 210	10	30	75	10
090 710 210	10	40	90	10
075 712 212	12	30	75	12

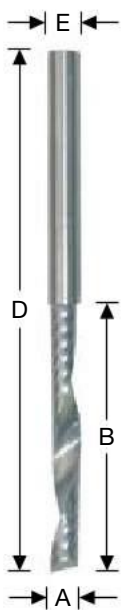

Wasserschlitzzfräser VHM

91120

Einschneidig, Bohrspitze, flacher Drallwinkel

- Spezialausführung für CNC-Maschinen, z.B. SUPER CUT, etc.
- zur PVC-Bearbeitung

Waterslot cutters - solid carbide -

- Single flute, drill point, flat twist angle
- special version for CNC-machines as SUPER CUT, etc.
- for UPVC-working

Art.-Nr.	A	B	D	E
060 705 305	5	25	60	5
080 705 305	5	40	80	5
080 706 306	6	40	80	6

Wasserschlitzfräser VHM

91121

Einschneidig, spiralig, mit Bohrspitze 90°

- Spezialausführung für CNC-Maschinen
- für Bearbeitungszentren von elumatec, Haffner, Handtmann, HEFI, Rapid, Schirmer, Stürtz, etc.
- zur PVC-Bearbeitung

Waterslot cutters – solid carbide –

Single flute, spiral, with drill point 90°

- special version for CNC-machines
- for machining-centres as elumatec, Haffner, Handtmann, HEFI, Rapid, Schirmer, Stürtz, etc.
- for UPVC-working

Art.-Nr.	A	B	C	D	E
080 705 405	5	40		80	5
060 708 095	5	20		60	8
010 718 295	5	25	42	100	8
080 708 395	5	30		80	8
080 708 405	5	40		80	8
090 718 395	5	35	55	90	8
010 718 395	5	35	55	100	8
080 706 406	6	40		80	6
090 706 456	6	45		90	6
010 718 906	6	35	72	110	8

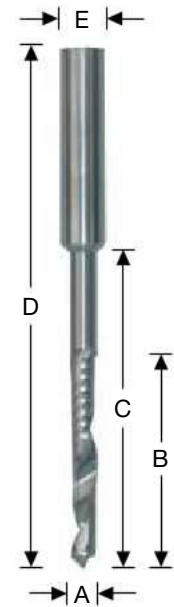

Wasserschlitzfräser VHM

91122

Einschneidig, spiralig

- zur PVC-Bearbeitung

Waterslot cutters – solid carbide –

Single flute, spiral

- for UPVC-working

Art.-Nr.	A	B	C	D	E
060 808 005	5	20		60	8
080 808 005	5	20	35	80	8
090 808 005	5	20	45	90	8
090 808 305	5	30		90	8
011 808 495	5	40	50	90	8
090 808 405	5	40	55	90	8
011 808 305	5	30	45	100	8
011 808 405	5	40	50	100	8
020 808 005	5	45	60	120	8

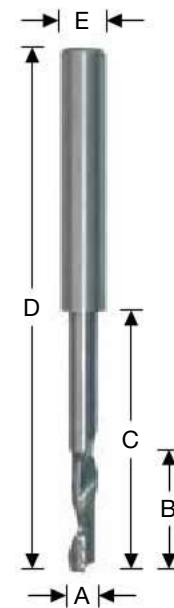

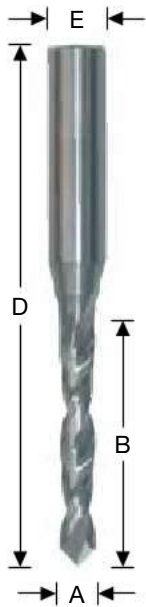

Wasserschlitzfräser VHM

91123

Zweischneidig mit Bohrspitze 90°

- für Bearbeitungszentren von elumatec, Haffner, Rapid, Schirmer, Stürtz, etc.
- zur PVC-Bearbeitung

Waterslot cutters – solid carbide –

Two flutes with drill point 90°

- for machining-centres as elumatec, Haffner, Rapid, Schirmer, Stürtz, etc.
- for UPVC-working

Art.-Nr.	A	B	D	E
014 705 005	5	40	80	5
014 705 405	5	40	100	5
014 708 265	5	20	60	8
014 708 375	5	30	70	8
014 708 405	5	40	80	8
014 708 205	5	20	85	8
014 708 305	5	30	90	8
014 708 415	5	40	100	8
014 708 455	5	45	100	8
014 708 406	6	40	75	8
014 708 496	6	40	95	8
014 708 306	6	30	90	8
014 708 456	6	45	90	8
014 708 658	8	65	100	8



Stufenfräser VHM

91124

Zweischneidig

- für Bearbeitungszentren von elumatec, Haffner, Rapid, Stürtz, etc.
- für PVC-Bearbeitung

Stepped cutters – solid carbide –

Two flutes

- for machining-centres as elumatec, Haffner, Rapid, Stürtz, etc.
- for UPVC-working

Art.-Nr.	d1	L1	d2	L2	D	E
922 083 433	2,0	4,5	5	20	60	8
922 083 447	2,5	4,5	5	20	60	8
922 083 432	2,5	4,5	5	30	70	8
922 083 441	3	4,5	5	20	60	8
922 083 425	3	4,5	5	30	70	8
922 083 450	3	5,5	5	30	70	8
922 083 426	3	4,5	5	40	80	8
922 083 540	3	5,5	5	40	100	8
922 083 440	4	10	5	40	80	8
954 505 004	4	20	8	57	100	8

Wasserschlitzfräser VHM

91126

Einschneidig, spiralg

- für Bearbeitungszentrum AFS, BJM, Rotox, Schirmer
- 1 = Rechtslauf / Rechtsdrall
- 2 = Rechtslauf / Linksdrall
- 3 = Rechtslauf / Rechtsdrall + Vorbohrer 2,7x5
- 4 = Rechtslauf / Linksdrall + Vorbohrer 2,7x5
- zur PVC-Bearbeitung

Waterslot cutters – solid carbide –

Single flute, spiral

- for AFS, BJM, Rotox, Schirmer CNC-machining-centre
- 1 = RH cut / RH spiral
- 2 = RH cut / LH spiral
- 3 = RH cut / RH spiral + step 2,7x5
- 4 = RH cut / LH spiral + step 2,7x5
- for UPVC-working

Art.-Nr.	A	B	C	D	E	Bild/pic.
010 838 305	2,7/5	30	50	100	8	3
080 808 255	5	25		80	8	1
090 808 345	5	34	45	90	8	1
010 808 305	5	30	50	100	8	1
080 848 305	2,7/5	25		80	8	4
010 848 305	2,7/5	30	50	100	8	4
080 828 255	5	25		80	8	2
080 828 355	5	35		80	8	2
010 828 305	5	30	50	100	8	2

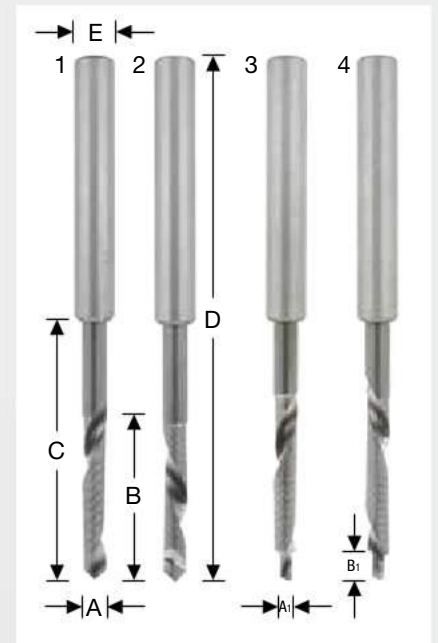

T-Nutenfräser VHM

91125

zum Verputzen der Innenecken

- für Bearbeitungszentren von elumatec, Rotox, Stürtz, Urban
- weitere Typen und Abmessungen lieferbar

T-slot cutters – solid carbide –

for inside corner cleaning

- for machining-centres as elumatec, Rotox, Stürtz, Urban
- various types and sizes available

Art.-Nr.	A	B	D	E	Z/T
010 788 090	8	20	100	8	4
273 513 210	8	30	100	8	2
273 513 090	9	50	100	8	2
273 513 110	10	25	100	8	2
273 513 120	12	45	100	8	2
273 515 180	12	50	100	8	2
273 513 100	14	45	100	8	2

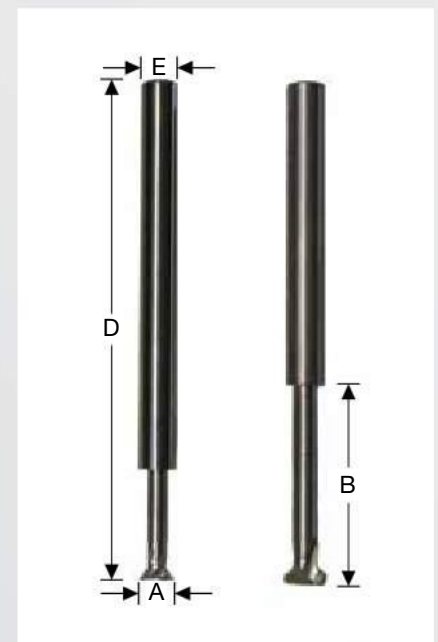

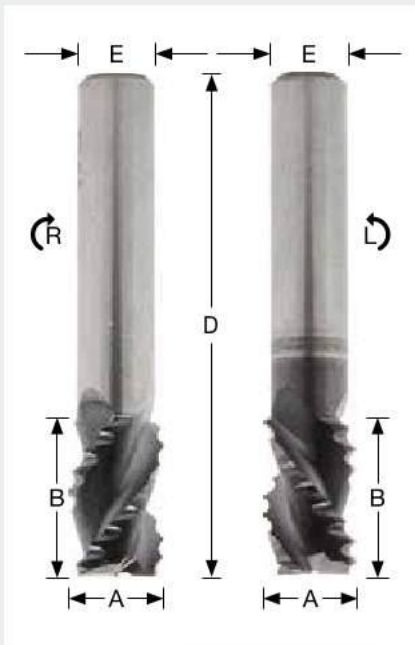

Fräser für Schweißmaschinen - VHM

95110

z. B. für Graf
- Diamant-Version auf Anfrage

Milling cutters – solid carbide –

e.g. for Graf
- Diamond-version upon request

Art.-Nr.	A	B	D	E	
030 705 630	6	10	30	5	R
030 705 631	6	10	30	5	L
032 705 630	6	10	32	5	R
032 705 631	6	10	32	5	L
035 705 630	6	10	35	5	R
035 705 631	6	10	35	5	L

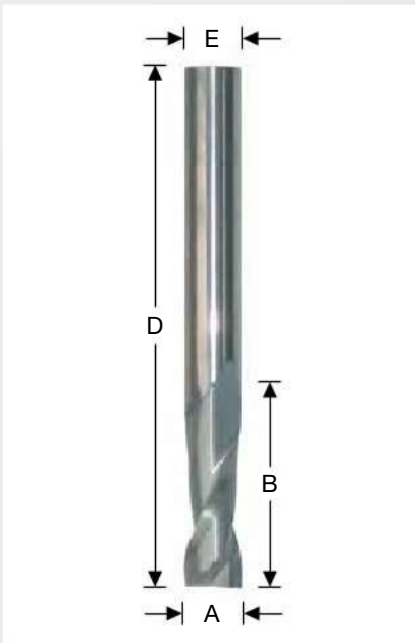

Bohrnutenfräser VHM

91140

Mehrschneidig, spiralig
- universell einsetzbar, für alle Bearbeitungszentren

Milling cutters – solid carbide –

Multi-edged, spiral
- All-purpose tool, for all kind of CNC-machines

Art.-Nr.	A	B	C	D	E	
058 706 025	2,5	8		58	6	⊖
082 705 305	5	30		70	5	⊖
082 718 206	6	20	60	120	8	⊖
082 706 406	6	40		100	6	⊖
082 708 608	8	18		60	8	⊖
082 708 008	8	35		80	8	⊖
082 708 108	8	40		100	8	⊖
082 708 708	8	70		150	8	⊖
140 392 208	8	12	55	80	8	elumatec Z-2 ⊖
082 711 008	8	35	42	100	10	⊖
140 390 210	10	22		70	10	elumatec Z-2 ⊖
082 710 210	10	22		72	10	⊖
140 391 210	10	12	60	90	10	elumatec Z-2 ⊖
082 710 010	10	40		100	10	⊖
140 392 210	10	12	80	110	10	elumatec Z-2 ⊖
082 710 710	10	70		150	10	⊖
082 712 212	12	22		70	12	⊖
140 390 212	12	22		70	12	elumatec Z-2 ⊖
140 391 212	12	12	60	100	12	elumatec Z-2 ⊖
082 712 412	12	45		100	12	⊖
082 712 512	12	40		120	12	⊖
082 714 414	14	45		100	14	⊖
140 390 216	16	22		70	16	elumatec Z-2 ⊖
082 716 416	16	45		100	16	⊖
140 391 316	16	32	60	102	16	elumatec Z-3 ⊖
140 391 317	16	35	70	110	16	elumatec Z-3 ⊖
082 716 216	16	20	60	115	16	⊖
082 716 116	16	70		150	16	⊖
060 409 905 42	16	35	90	130	16	elumatec Z-3 ⊖
060 409 900 42	20	20	70	125	20	elumatec Z-2 ⊖

⊖ Zweischneider / 2-flutes

⊗ Dreischneider / 3-flutes

elumatec Z-2 / Z-3

= Spiegelschliff / Mirror polish

Schafffräser VHM - HSC-Schrupfräser „ZR“

91141









Zur Bearbeitung von Aluminiumprofilen auf CNC Bearbeitungszentren



- höchste Präzision
- sehr hohe Schnittgeschwindigkeit
- hervorragende Standzeit
- beschichtet

Milling cutters – solid carbide – HSC-roughing „ZR“–

Special version for high-speed cutting/HSC of aluminium

- extrusions on CNC-machining-centres
- highest precision
- more speed and feed
- extreme lifespan
- coated

Art.-Nr.	A	B	C	D	E	Z/T	
057 744 002	2	10		57	6	3	
057 744 003	3	15	23	57	6	3	
057 744 004	4	15	23	57	6	3	
057 744 005	5	15	23	57	6	3	
057 744 006	6	15	23	57	6	3	
072 744 008	8	22		72	8	3	
072 744 010	10	25		72	10	3	
080 744 012	12	30		80	12	3	
010 744 016	16	30	50	100	16	4	

 Dreischneider / 3-flutes  Vierschneider / 4-flutes

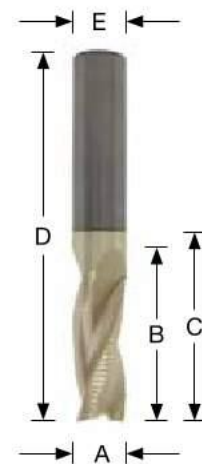

Bohrnutenfräser VHM – Spiegelschliff - Trockenfräsen – 91142





Spezialausführung zur Hochgeschwindigkeitsbearbeitung auf leistungsfähigen (Profil)-Bearbeitungszentren



- z. B. bavivus, elumatec, Emmegi, Mecal, Schüco, etc.
- DLC Spezialbeschichtung zur Trockenbearbeitung von Al-Legierungen
- bestmögliche Standzeit bei hervorragenden Bearbeitungsergebnissen
- Schnittwertabelle auf Anfrage

Milling cutters – solid carbide - polished dry cut –

Highspeed cutting HSC for powerful CNC-(profile) machining centres

- as bavivus, elumatec, Emmegi, Mecal, Schüco, etc.
- DLC high-performance coating for dry machining of all common aluminium alloys
- maximum tool life with excellent machining results
- Cutting value table upon request

Art.-Nr.	A	B	C	D	E	
082 688 010	10	20		70	10	
140 399 012 10	10	12	60	90	10	
082 688 210	10	12	80	110	10	
082 688 012	12	22		70	12	
140 399 012 12	12	18	60	100	12	
082 688 016	16	22		70	16	
140 399 013 16	16	32	60	102	16	
140 399 113 16	16	35	90	130	16	

 Zweischneider / 2-flutes  Dreischneider / 3-flutes

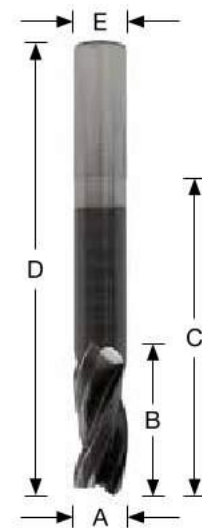

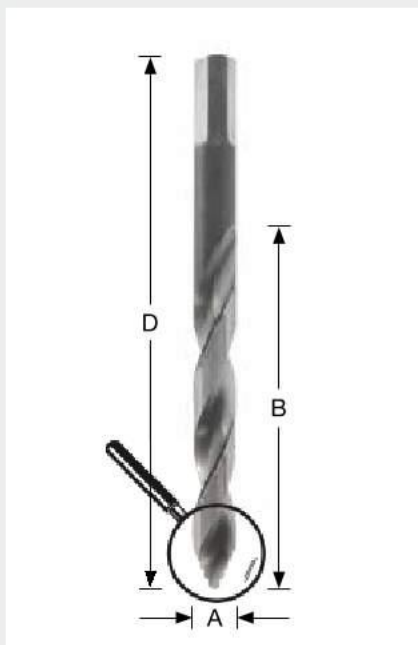

geschliffen, mit Stufengeometrie

- DIN 338
- Kobalt legiert
- Mehrbereichs- / Hochleistungs-Spezialbohrer
- ideal für Akkuschauber
- vereinfachtes Aufbohren bestehender Löcher
- perfekte Zentrierung und kreisrunde Bohrungen
- minimaler Kraftaufwand

1 VE = 10 Stück: Ø 3,0 bis 6,5 mm

1 VE = 5 Stück: Ø 7,0 bis 13,0 mm

Twist drills HSS CO - TurboStep –

fully ground, with step drillpoint

- DIN 338
- cobalt
- Jobber drills, heavy duty, all purpose tool
- ideal for cordless screwdrivers
- simplified drilling of existing holes
- perfect centering and circular drill holes
- minimal effort required

1 Packing unit = 10 pieces: Ø 3,0 up to 6,5 mm

1 Packing unit = 5 pieces: Ø 7,0 up to 13,0 mm



Art.-Nr.	A	B	D
303 003 030	3,0	33	61
303 003 032	3,2	36	65
303 003 035	3,5	39	70
303 003 040	4,0	43	75
303 003 042	4,2	43	75
303 003 045	4,5	47	80
303 003 050	5,0	52	86
303 003 055	5,5	57	93
303 003 060	6,0	57	93
303 003 062	6,2	63	101
303 003 065	6,5	63	101
303 003 070	7,0	69	109
303 003 075	7,5	69	109
303 003 080	8,0	75	117
303 003 085	8,5	75	117
303 003 090	9,0	81	125
303 003 100	10,0	87	133
303 003 105	10,5	87	133
303 003 110	11,0	94	142
303 003 120	12,0	101	151
303 003 125	12,5	101	151
303 003 130	13,0	101	151

geschliffen

- DIN 338 N
- Präzisionsausführung
- weitere Abmessungen auf Anfrage

1 VE = 10 Stück: Ø 2,0 bis 6,5 mm

1 VE = 5 Stück: Ø 7,0 bis 13,0 mm

Twist drills HSS

fully ground

- DIN 338 N
- short, precision
- other dimensions upon demand

1 Packing unit = 10 pieces: Ø 2,0 up to 6,5 mm

1 Packing unit = 5 pieces: Ø 7,0 up to 13,0 mm

Art.-Nr.	A	B	D
303 001 020	2,0	24	49
303 001 025	2,5	30	57
303 001 030	3,0	33	61
303 001 032	3,2	36	65
303 001 035	3,5	39	70
303 001 040	4,0	43	75
303 001 042	4,2	43	75
303 001 045	4,5	47	80
303 001 050	5,0	52	86
303 001 055	5,5	57	93
303 001 060	6,0	57	93
303 001 065	6,5	63	101
303 001 070	7,0	69	109
303 001 075	7,5	69	109
303 001 080	8,0	75	117
303 001 085	8,5	75	117
303 001 090	9,0	81	125
303 001 100	10,0	87	133
303 001 110	11,0	94	142
303 001 120	12,0	101	151
303 001 130	13,0	101	151
303 001 140	14,0	108	160
303 001 150	15,0	114	169

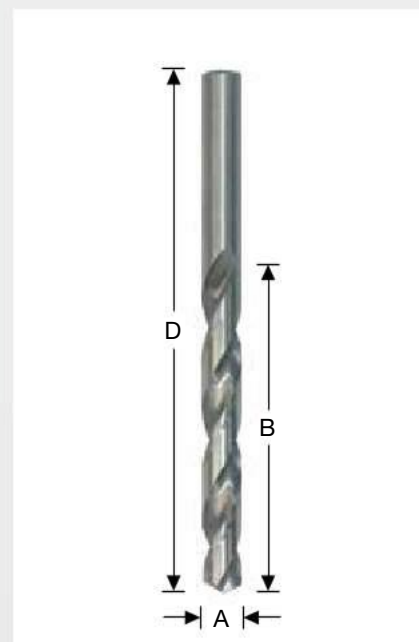

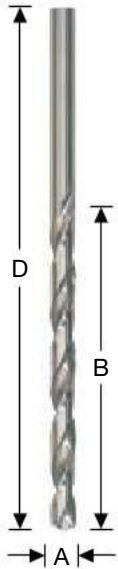

Spiralbohrer HSS

91211

geschliffen
- DIN 340 N
- Präzisionsausführung

1 VE = 10 Stück: Ø 2,0 bis 6,0 mm
1 VE = 5 Stück: Ø 6,5 bis 10,0 mm

Twist drills HSS

fully ground
- DIN 340 N
- long, precision

1 Packing unit = 10 pieces: Ø 2,0 up to 6,0 mm
1 Packing unit = 5 pieces: Ø 6,5 up to 10,0 mm

Art.-Nr.	A	B	D
302 002 020	2,0	56	85
302 002 025	2,5	62	92
302 002 030	3,0	66	100
302 002 032	3,2	69	106
302 002 035	3,5	73	112
302 002 040	4,0	78	119
302 002 042	4,2	78	119
302 002 045	4,5	82	126
302 002 050	5,0	87	132
302 002 055	5,5	91	139
302 002 060	6,0	91	139
302 002 065	6,5	97	148
302 002 070	7,0	102	156
302 002 075	7,5	102	156
302 002 080	8,0	109	165
302 002 085	8,5	109	165
302 002 090	9,0	115	175
302 002 095	9,5	115	175
302 002 100	10,0	121	184

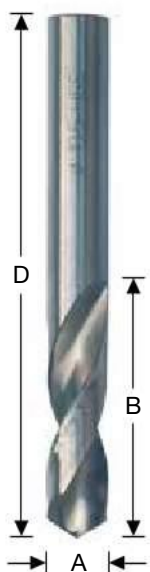

Spiralbohrer HSS

91221

geschliffen
- DIN 1897
- kurze Ausführung
- R = rechts- und L = linksdrehend

1 VE = 10 Stück: Ø 1,0 bis 6,5 mm
1 VE = 5 Stück: Ø 7,0 bis 13,0 mm

Twist drills HSS

fully ground
- DIN 1897
- short, precision
- RH and LH rotation

1 Packing unit = 10 pieces: Ø 1,0 up to 6,5 mm
1 Packing unit = 5 pieces: Ø 7,0 up to 13,0 mm

Art.-Nr. R = Rechts / RH	A	B	D	Art.-Nr. L = Links / LH
303 004 030	3,0	16	46	303 024 030
303 004 040	4,0	22	55	303 024 040
303 004 050	5,0	26	62	303 024 050
303 004 060	6,0	28	66	303 024 060
303 004 080	8,0	37	79	
303 004 100	10,0	43	89	
303 004 110	11,0	47	95	
303 004 120	12,0	51	102	
303 004 130	13,0	51	102	

Spiralbohrer HSS-G

91225

geschliffen

- DIN 1869
- Präzisionsausführung
- überlange Ausführung, Tieflochspirale

Twist drills HSS-G

fully ground

- DIN 1869
- extra long, precision

Art.-Nr.	A	B	D
303 008 020	2,0	85	125
303 008 025	2,5	95	140
303 008 030	3,0	100	150
303 008 032	3,2	105	155
303 008 035	3,5	115	165
303 008 040	4,0	120	175
303 008 042	4,2	120	175
303 008 045	4,5	125	185
303 008 050	5,0	135	195
303 008 055	5,5	140	205
303 008 060	6,0	140	205
303 008 065	6,5	150	215
303 008 070	7,0	155	225
303 008 075	7,5	155	225
303 008 080	8,0	165	240
303 008 085	8,5	165	240
303 008 090	9,0	175	250
303 008 095	9,5	175	250
303 008 100	10,0	185	265
303 008 105	10,5	185	265
303 008 110	11,0	195	280
303 008 115	11,5	195	280
303 008 120	12,0	205	295
303 008 130	13,0	205	295

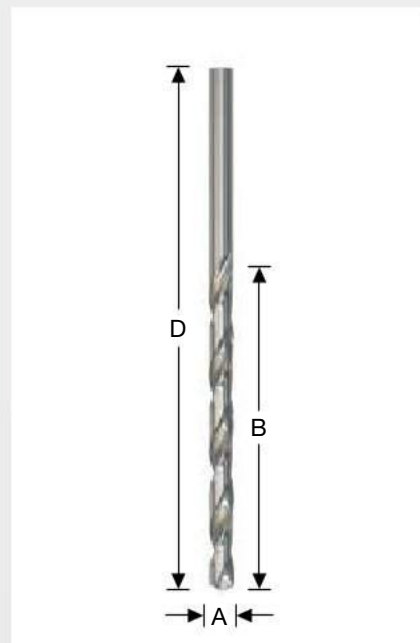

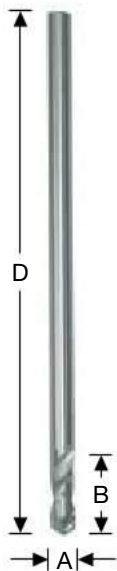

geschliffen

- Spezialbohrer
- zum Bohren von Stahlprofilblech-Konstruktionen und Fensterprofilen
- extra kurze Spirale, geringe Bruchgefahr

Window construction twist drills HSS

fully ground

- special drills
- extra short flute, break-proof

Art.-Nr.	A	B	D	
306 100 030	3,0	30	100	
306 100 040	4,0	30	100	
306 150 050	5,0	30	150	
306 150 055	5,5	30	150	
306 150 060	6,0	30	150	
306 150 065	6,5	30	150	
306 150 100	10,0	30	150	
306 150 105	10,5	30	150	
306 180 050	5,0	30	180	
306 180 055	5,5	30	180	
306 180 060	6,0	30	180	
306 180 065	6,5	30	180	
306 180 080	8,0	30	180	
306 180 085	8,5	30	180	
306 180 100	10,0	30	180	
306 180 105	10,5	30	180	
306 180 265	6,5	30	180	Spanbrecher / Chipbreaker
306 180 280	8,0	30	180	Spanbrecher / Chipbreaker
306 180 210	10,0	30	180	Spanbrecher / Chipbreaker
306 180 215	10,5	30	180	Spanbrecher / Chipbreaker



geschliffen

- DIN 338
- Kobalt legiert
- Mehrbereichs- / Hochleistungs-Spezialbohrer

1 VE = 10 Stück: Ø 2,0 bis 6,0 mm

1 VE = 5 Stück: Ø 6,2 bis 12,0 mm

Twist drills HSS CO

fully ground

- DIN 338
- cobalt
- precision
- jobber drills, heavy duty, all purpose tool

1 Packing unit = 10 pieces: Ø 2,0 up to 6,0 mm

1 Packing unit = 5 pieces: Ø 6,2 up to 12,0 mm

Art.-Nr.	A	B	D
303 007 020	2,0	24	49
303 007 025	2,5	30	57
303 007 030	3,0	33	61
303 007 032	3,2	36	65
303 007 035	3,5	39	70
303 007 040	4,0	43	75
303 007 042	4,2	43	75
303 007 045	4,5	47	80
303 007 050	5,0	52	86
303 007 055	5,5	57	93
303 007 060	6,0	57	93
303 007 062	6,2	63	101
303 007 065	6,5	63	101
303 007 070	7,0	69	109
303 007 075	7,5	69	109
303 007 080	8,0	75	117
303 007 085	8,5	75	117
303 007 090	9,0	81	125
303 007 100	10,0	87	133
303 007 105	10,5	87	133
303 007 110	11,0	94	142
303 007 120	12,0	101	151
303 007 130	13,0	101	151

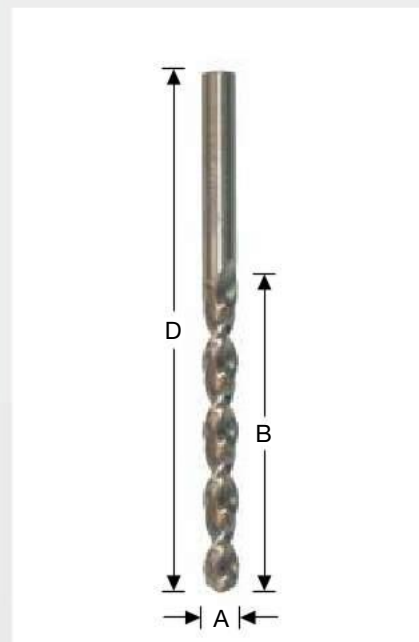

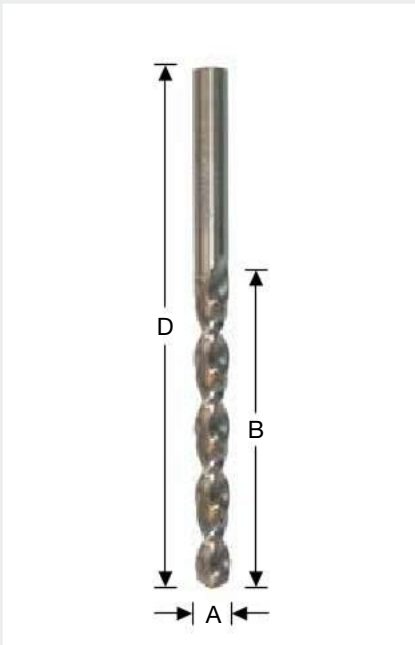

Spiralbohrer HSS CO

91232

geschliffen

- DIN 340
- Kobalt legiert
- Mehrbereichs- / Hochleistungs-Spezialbohrer

1 VE = 10 Stück: Ø 3,0 bis 6,0 mm

1 VE = 5 Stück: Ø 6,5 bis 10,0 mm

Twist drills HSS CO

fully ground

- DIN 340
- cobalt
- precision
- jobber drills, heavy duty, all purpose tool

1 Packing unit = 10 pieces: Ø 3,0 up to 6,0 mm

1 Packing unit = 5 pieces: Ø 6,5 up to 10,0 mm

Art.-Nr.	A	B	D
303 009 030	3,0	66	100
303 009 032	3,2	69	106
303 009 035	3,5	73	112
303 009 040	4,0	78	119
303 009 042	4,2	78	119
303 009 045	4,5	82	126
303 009 050	5,0	87	132
303 009 055	5,5	91	139
303 009 060	6,0	97	139
303 009 065	6,5	97	148
303 009 070	7,0	102	156
303 009 080	8,0	109	165
303 009 090	9,0	115	175
303 009 100	10,0	121	184

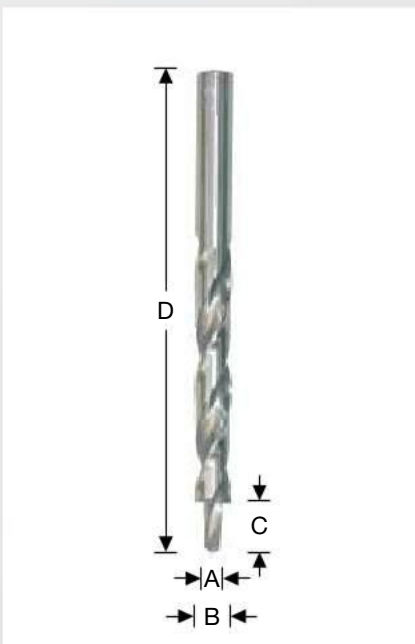

Stufenbohrer HSS

91250

Winkel 180° (für Zylinderkopfschraube)

- zur Bearbeitung von Aluminium- und Kunststoffprofilen
- weitere Abmessungen und Ausführungen kurzfristig auf Anfrage lieferbar!

Step drill bits HSS

Angle 180° (for cylinder head screw)

- for working aluminium and UPVC-profiles
- other sizes and types are shortly available upon demand!

Art.-Nr.	A	B	C	D	
301 008 004	4,3	8,0	11	117	180°
301 010 005	5,3	10,0	13	133	180°
301 104 053	5,3	10,4	10	133	180°
301 012 006	6,4	12,0	15	151	180°
301 120 700	7,0	12,0	10	151	180°
301 012 008	8,0	12,0	15	151	180°
301 130 800	8,0	13,0	10	151	180°

Stufenbohrer HSS

91260

Winkel 90° (für Senkschraube)

- zur Bearbeitung von Aluminium- und Kunststoffprofilen
- * kurze Ausführung für Bearbeitungszentren
- weitere Abmessungen und Ausführungen kurzfristig auf Anfrage lieferbar!

Step drill bits HSS

Angle 90° (for cheese head screw)

- for working aluminium and UPVC-profiles
- * short version for CNC-machines
- other sizes and types are shortly available upon demand!

Art.-Nr.	A	B	C	D	
301 108 004	4,3	8,0	11	117	90°
301 111 005	5,0	11,0	6	142	90°
301 112 005	5,0	12,0	20	100	90°
301 110 005	5,3	10,0	13	133	90°
301 112 006	6,4	12,0	15	151	90°
301 208 004*	4,3	8,0	11	79	90°
301 210 005*	5,3	10,0	13	89	90°
301 210 006*	6,4	12,0	15	102	90°

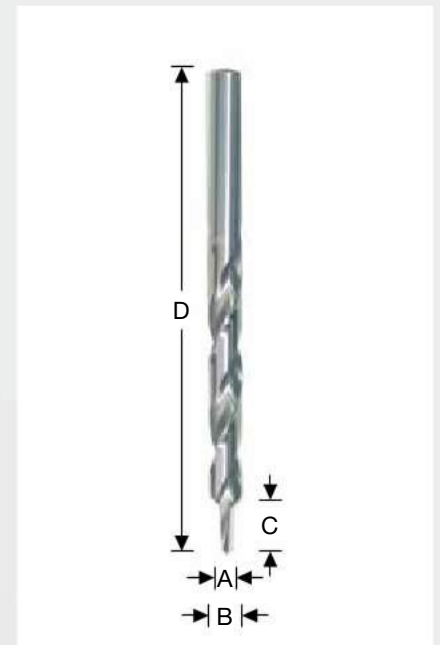

Olivenbohrer HSS CO

91261

Winkel 90°

- Schaft mit Fläche
- R = Rechtslauf - L = Linkslauf

keine Lagerartikel - Lieferzeit auf Anfrage!

Drills for handle hole, HSS CO

Angle 90°

- cylindric shank with flat
- R = RH-rotation - L = LH-rotation

no standard stock item - delivery time upon request!

Art.-Nr.	A	C	B	D	E	
301 207 055	5,5	7	11	107	8	R
301 210 055	5,5	7	11	110	8	R
301 210 155	5,5	7	12	115	8	L
301 210 255	5,5	7	11	115	8	R
301 212 255	5,5	7	12	120	8	L
301 310 155	5,5	7	13	115	8	L
301 212 355	5,5	7	12	115	10	R
301 210 455	5,5	7	10	110	10	L
301 210 555	5,5	7	10	110	10	R



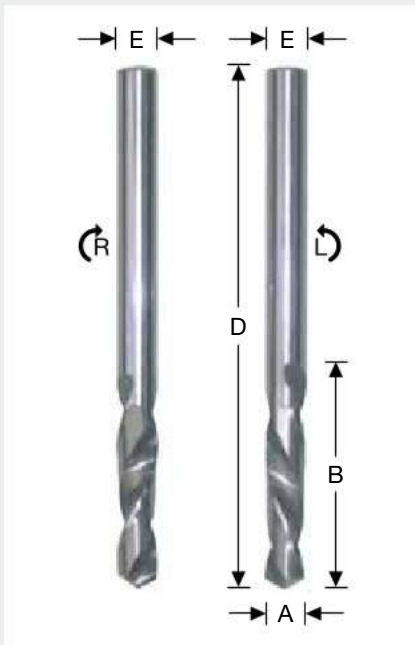

Spiralbohrer VHM

91262

Dachformspitze

- durchgehend zylindrisch
- Universalbohrer zum Einsatz auf Bearbeitungszentren
- für höchste Ansprüche und Standzeiten in Holz, PVC, Aluminium, GFK, Stahl, etc.
- R = Rechtslauf - L = Linkslauf auf Anfrage

Brad point drills – solid carbide –

with taper drills point

- cylindrical on the whole length
- all purpose drills.
- for use in CNC-machining centres,
- for best results in wood, UPVC, aluminium, glass fiber, steel, etc.
- R = RH-rotation - L = LH-rotation on demand

Art.-Nr.	A	B	D	E	
484 000 002	2,0	12	38	2,0	R
484 000 025	2,5	14	43	2,5	R
484 000 003	3,0	16	46	3,0	R
484 001 030	3,0	27	46	3,0	R
303 700 030	3,0	28	66	6,0	R
484 000 035	3,5	20	52	3,5	R
484 000 004	4,0	22	55	4,0	R
484 000 045	4,5	24	58	4,5	R
484 000 005	5,0	26	62	5,0	R
303 700 050	5,0	44	81	6,0	R
303 703 060	6,0	28	66	6,0	R
303 747 060	6,0	57	93	6,0	R
484 000 008	8,0	37	79	8,0	R
303 747 080	8,0	75	117	8,0	R

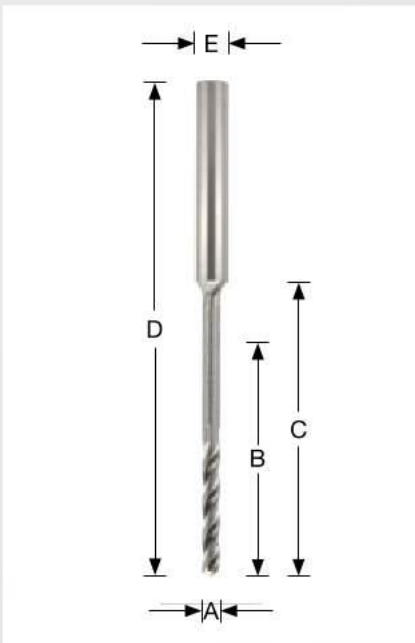

Spiralbohrer VHM, Z-3

91263

Dreischneidiger Hochleistungsbohrer

- sehr gute Zentrierung und geringe Vorschubkraft
- z. B. für Schüco etc.

Twist drills – solid carbide – , 3-flutes

Three-flute high performance drills bit

- excellent centering ability and minimum feed pressure
- e. g. Schüco etc.

Art.-Nr.	A	B	C	D	E
000 283 781	2,5	20	52	90	6
000 283 783	3,2	20	52	90	6
000 289 456	3,5	20	52	90	6
000 283 784	4,2	20	62	100	6
000 283 785	5,0	20	70	100	6

Mehrstufenbohrer HSS

91265

für gratfreies Bohren und Aufreiben von Blechen, Rohren und Profilen
C = Abstufung

Multi Step drills HSS

All purpose step drills for sheet metal, tubes and profiles
C = Stepped

Art.-Nr.	A	B	C	E
304 000 001	4	12	1	6
304 000 002	6	20	2	8
304 000 003	6	30	2	8



Kegel- und Entgratsenker, 90°, HSS + VHM

91266

dreischneidig, rechtsschneidend
- Zylinderschaft

Counter sinks, 90°, HSS + tungsten carbide

three flutes, RH
- cylindric shank

Art.-Nr.	Art.-Nr. VHM/TC	A	B	E
310 004 043	-	4,3	1,5	4
310 005 050	-	5,0	2,0	4
310 005 053	-	5,3	2,0	4
310 006 060	-	6,0	2,0	5
310 006 063	310 705 063	6,3	2,0	5
310 006 070	-	7,0	3,0	6
310 006 073	-	7,3	3,0	6
310 006 080	-	8,0	3,0	6
310 006 083	310 706 083	8,3	3,0	6
310 006 094	-	9,4	4,0	6
310 006 100	-	10,0	4,0	6
310 006 104	310 706 104	10,4	4,0	6
310 008 115	-	11,5	4,0	8
310 008 124	310 708 124	12,4	4,0	8
310 008 134	-	13,4	5,0	8
310 008 150	-	15,0	5,0	8
310 010 165	310 710 165	16,5	5,0	10
310 010 190	-	19,0	5,0	10
310 010 205	310 710 205	20,5	5,0	10
310 012 230	-	23,0	6,0	10
310 012 250	310 710 250	25,0	6,0	10
310 012 280	-	28,0	7,0	12
310 012 310	310 712 310	31,0	7,0	12



Kegel- und Entgratsenker mit Querloch

91267

Senkwinkel 90°

- zum Entgraten von Bohrungen

Counter sinks with cross-hole

90° zero flute

- to deburr drill holes



Art.-Nr.	A	E
311 000 002	2/5	6
311 000 005	5/10	8
311 000 010	10/15	10
311 000 015	15/20	12
311 000 020	20/25	12
311 000 025	25/30	15

Kombi-Maschinengewindebohrer HSS-E

91268

zum Kernlochbohren, Gewindeschneiden und Entgraten in **einem** Arbeitsgang

Combined machine taps HSS-E

to drill cored hole, thread cutting and deburr in **one** operation

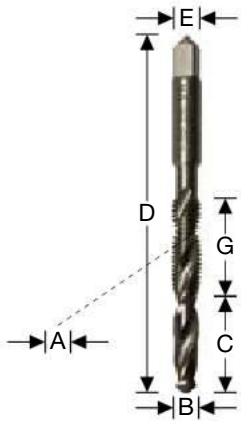

Art.-Nr.	A	B	C	G	D	E
312 000 003	M3	2,5	16	11	56	3,0
312 000 004	M4	3,3	18	14	63	4,0
312 000 005	M5	4,2	20	18	71	5,0
312 000 006	M6	5,0	22	22	80	6,0
312 000 008	M8	6,8	26	25	95	8,0
312 000 010	M10	8,5	30	31	106	10,0
312 000 012	M12	10,2	32	35	115	12,0

Spezial-Stufenbohrer – THORWESTEN –

91270

neue Version

- für PVC-/ Stahlbearbeitung auf Bearbeitungszentren THORWESTEN

- beschichtet

Special stepped drill – THORWESTEN –

new version

- for UPVC/ steel reinforcement working on CNC machine THORWESTEN

- coated



Art.-Nr.	A	D	E
304 007 020	20	100	16



Kennen Sie eigentlich schon,
Do you already know,

.....unsere Homepage inklusive B2B webshop?

.....our homepage including our B2B webshop?



.....und unsere Social-Media-Kanäle?

.....and our social media channels?



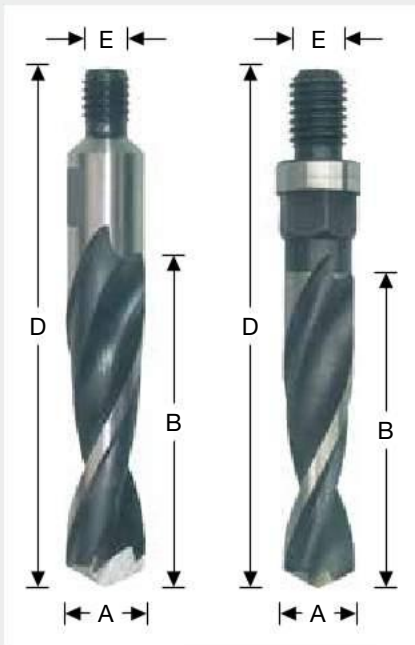

Olivenbohrer HSS-E

91300

Dachformspitze, Rechtslauf, Aussengewinde

- zur Bearbeitung von Kunststoffprofilen mit oder ohne Stahleinlage

Threaded drills HSS-E

taper drill point, RH-rotation, male thread

- for working of UPVC profiles with or without filling steel profile

Art.-Nr.	A	B	D	E	
492 050 010	10	50	87	M6	Konus / cone
488 030 010	10	30	65	M10	
482 050 010	10	45	78	M8	Konus / cone
496 050 010	10	30	76	M10	
480 050 010	10	50	87	M10	
480 080 010	10	80	113	M10	
492 050 012	12	50	87	M6	Konus / cone
482 050 012	12	45	78	M8	Konus / cone
488 030 012	12	30	65	M10	
496 050 012	12	30	76	M10	
480 050 012	12	50	87	M10	
480 080 012	12	80	113	M10	
492 050 014	14	50	87	M6	Konus / cone
482 050 014	14	45	78	M8	Konus / cone
488 030 014	14	30	65	M10	
496 050 014	14	30	76	M10	
480 050 014	14	50	87	M10	
480 080 014	14	80	113	M10	

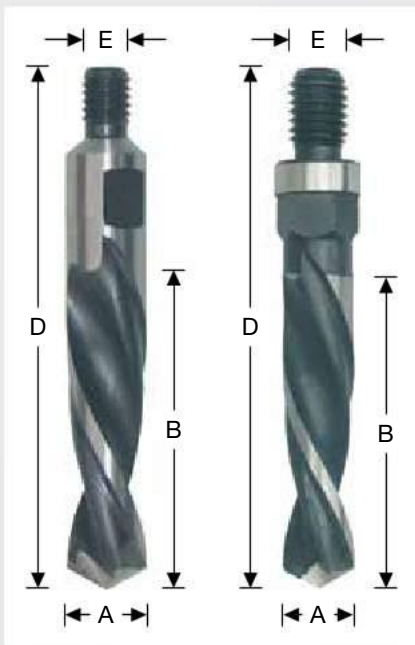

Olivenbohrer HSS-E

91301

Dachformspitze, Linkslauf, Aussengewinde

- zur Bearbeitung von Kunststoffprofilen mit oder ohne Stahleinlage

Threaded drills HSS-E

taper drill point, LH-rotation, male thread

- for working of UPVC profiles with or without filling steel profile

Art.-Nr.	A	B	D	E	
483 050 010	10	45	78	M8	Konus / cone
489 030 010	10	30	60	M10	
497 050 010	10	30	72	M10	
481 050 010	10	50	87	M10	
481 080 010	10	80	113	M10	
483 050 012	12	45	78	M8	Konus / cone
489 030 012	12	30	60	M10	
497 050 012	12	30	72	M10	
481 050 012	12	50	87	M10	
481 060 010	10	60	100	M10	
481 080 012	12	80	113	M10	
483 050 014	14	45	78	M8	Konus / cone
481 060 012	12	60	100	M10	
489 030 014	14	30	60	M10	
497 050 014	14	30	72	M10	
481 050 014	14	50	87	M10	
481 080 014	14	80	113	M10	

Olivenbohrer HSS-E

91310

Vorböhrer, Rechtslauf, Aussengewinde

- zur Bearbeitung von Kunststoffprofilen mit oder ohne Stahleinlage

Threaded drills HSS-E

piloted version, RH-rotation, male thread

- for working of UPVC profiles with or without filling steel profile

Art.-Nr.	A	B	D	E	
490 050 010	10	45	78	M8	Konus / cone
476 030 010	10	35	76	M10	
486 150 010	10	50	84	M10	
486 050 010	10	50	87	M10	
486 060 010	10	60	100	M10	
486 080 010	10	80	113	M10	
490 050 012	12	45	78	M8	Konus / cone
476 030 012	12	30	76	M10	
486 150 012	12	50	84	M10	
486 050 012	12	50	87	M10	
486 060 012	12	60	100	M10	
486 080 012	12	80	113	M10	
490 050 014	14	45	78	M8	Konus / cone
476 030 014	14	30	76	M10	
486 150 014	14	50	84	M10	
486 050 014	14	50	87	M10	
486 080 014	14	80	113	M10	

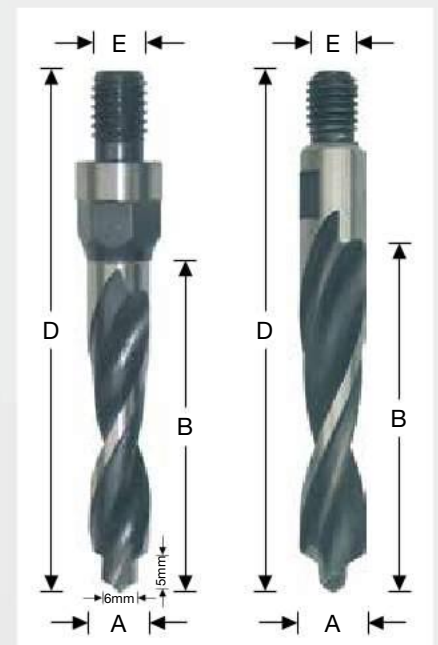

Olivenbohrer HSS-E

91311

Vorböhrer, Linkslauf, Aussengewinde

- zur Bearbeitung von Kunststoffprofilen mit oder ohne Stahleinlage

Threaded drills HSS-E

piloted version, LH-rotation, male thread

- for working of UPVC profiles with or without filling steel profile

Art.-Nr.	A	B	D	E	
491 050 010	10	45	78	M8	Konus / cone
477 030 010	10	35	72	M10	
487 150 010	10	50	84	M10	
487 150 012	12	50	84	M10	
487 050 010	10	50	87	M10	
487 060 010	10	60	100	M10	
487 080 010	10	80	113	M10	
491 050 012	12	45	78	M8	Konus / cone
477 030 012	12	35	72	M10	
487 050 012	12	50	87	M10	
487 060 012	12	60	100	M10	
487 080 012	12	80	113	M10	
491 050 014	14	45	78	M8	Konus / cone
477 030 014	14	35	72	M10	
487 050 014	14	50	87	M10	
487 080 014	14	80	113	M10	



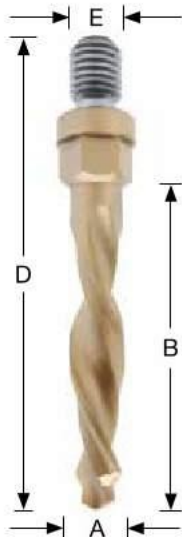

Olivenbohrer HSS-E

91312

Vorbohrer, R = Rechtslauf, L = Linkslauf, Aussengewinde M10

- Zur Bearbeitung von Kunststoffprofilen **mit** Stahleinlage
- Spezialbeschichtung „SteelMaxx“

Threaded drills HSS-E

piloted version, R = RH-rotation, L = LH-rotation, male thread M10

- for working of UPVC profiles **with** filling steel profile
- special coated „SteelMaxx“

Art.-Nr.	A	B	D	E	
486 650 010	10	50	87	M10	R
486 650 012	12	50	87	M10	R
486 680 012	12	80	113	M10	R
486 680 014	14	80	113	M10	R
487 651 010	10	50	84	M10	L
487 650 010	10	50	87	M10	L
487 650 012	12	50	87	M10	L
487 680 012	12	80	113	M10	L



Olivenbohrer HSS-E

91315

Spanbrecher, Dachformspitze, Spezialbeschichtung für Stahl, Aussengewinde M10

- für Bearbeitungszentren
- R = Rechtslauf - L = Linkslauf

Threaded drills HSS-E

additional chip breaker, taper drill point, special coating for steel, male thread M10

- used on CNC-machining centres
- R = RH-rotation - L = LH-rotation

Art.-Nr.	A	B	D	E	
498 050 010	10	50	87	M10	R
498 050 012	12	50	87	M10	R
498 050 014	14	50	87	M10	R
498 060 010	10	60	97	M10	R
498 060 012	12	60	97	M10	R
498 060 013	13	60	97	M10	R
499 050 010	10	50	87	M10	L
499 050 012	12	50	87	M10	L
499 050 014	14	50	87	M10	L
499 060 010	10	60	97	M10	L



Wussten Sie eigentlich schon,

.....dass die Ursachen der oftmals auftretenden Probleme beim Bohren der Armierungsstähle im Kunststoff-Fensterbau meist keine Qualitätsprobleme der Bohrwerkzeuge sind, sondern der Profilstähle.

Ganz wichtig sind korrekte Drehzahlen der Bohrer, um die Wärmeentwicklung möglichst gering zu halten.

Hochtemperatur-Beschichtungen können Abhilfe schaffen.

Wir beraten Sie gerne.

Olivenbohrer HSS-E – QUADRO –

91317

4-schneidig, Vorbohrer, Aussengewinde M10

- für Bearbeitungszentren z. B. Federhenn, Schirmer, Stürtz
- R = Rechtslauf - L = Linkslauf

Threaded drills HSS-E – QUADRO –

4-flutes, piloted version, male thread M10

- used on CNC-machining centres as Federhenn, Schirmer, Stürtz
- R = RH-rotation - L = LH-rotation

Art.-Nr.	A	B	D	E	
474 050 010	10	50	87	M10	R
474 050 012	12	50	87	M10	R
474 080 012	12	80	113	M10	R
474 100 012	12	100	128	M10	R
474 050 014	14	50	87	M10	R
475 050 010	10	50	87	M10	L
475 080 010	10	80	113	M10	L
475 100 010	10	100	128	M10	L
475 050 012	12	50	87	M10	L
475 050 014	14	50	87	M10	L

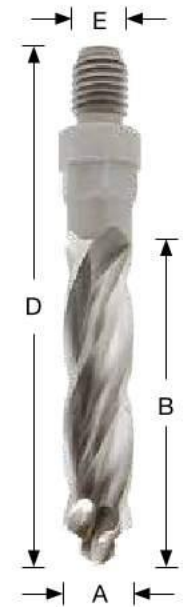

Olivenbohrer HSS-E – QUADRO –

91318

4-schneidig, Vorbohrer, Aussengewinde M10

- für Bearbeitungszentren z. B. Federhenn, Schirmer, Stürtz
- R = Rechtslauf - L = Linkslauf
- Spezialbeschichtung „SteelMaxx“

Threaded drills HSS-E – QUADRO –

4-flutes, piloted version, male thread M10

- used on CNC-machining centres as Federhenn, Schirmer, Stürtz
- R = RH-rotation - L = LH-rotation
- special coated „SteelMaxx“

Art.-Nr.	A	B	D	E	
474 650 010	10	50	87	M10	R
474 650 012	12	50	87	M10	R
475 650 010	10	50	87	M10	L

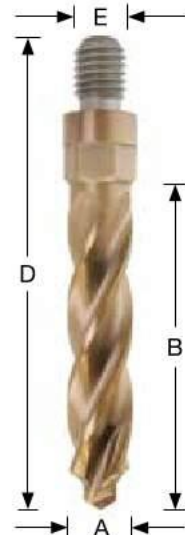

Did you actually know,

.....the causes of the often occurring problems when drilling reinforcement steel in UPVC-windows are usually not quality problems of the tools, but of the reinforcement steel profile.

Very important is correct speed of drills to keep the heat-development as low as possible.

High-temperature coatings can also help.

We are happy to help.

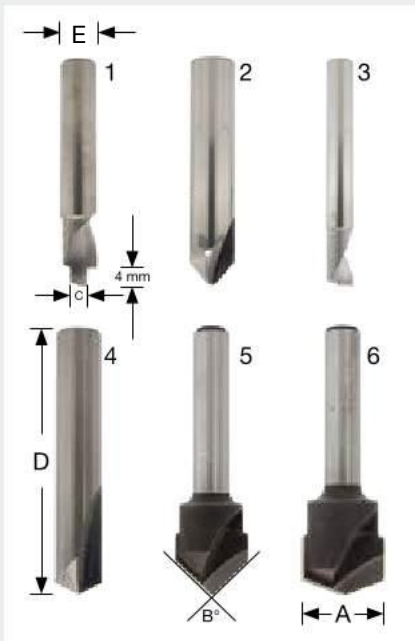

ALUCOBOND-Bearbeitung – Hartmetall –

91900

Nutfräser für Oberfräse / CNC-Fräse

ALUCOBOND – tungsten carbide –

Grooving bits for hand routers / CNC-machines

Art.-Nr.	A	B	C	D	E	Bild / pic.
054 372 503	6		4	50	6	1
054 372 504	8		4	50	8	1
054 372 506	10	95°		70	10	2
054 372 501	15,9	90°		60	8	5
054 372 502	18	135°		60	8	6
054 372 508	10	135°		50	10	4
054 372 509	10	100°		50	10	2
054 372 510	10		7	60	10	1
054 706 004	4			60	6	3
054 706 006	6			60	6	3
054 703 003	3			50	3	3
054 706 310	3			85	6	3
054 706 610	6			85	6	3
054 708 008	8			80	8	3



ALUCOBOND-Bearbeitung – DIA bestückt –

91903

V-Nutfräser für CNC-Fräse

ALUCOBOND – PCD tipped – / diamond

V-Grooving bits for CNC-machines

Art.-Nr.	A	B	D	E	Bild / pic.
054 382 006	6		55	6	3
054 382 501	12	90°	77	10	2
054 382 502	20	135°	65	10	1
054 382 508	35	135°	70	20	1

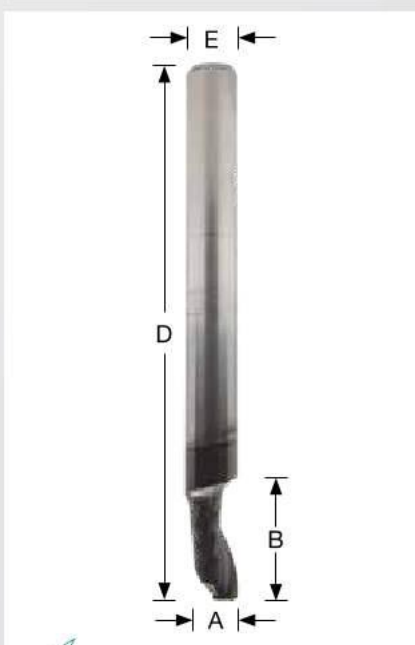

ALUCOBOND-Bearbeitung – DLC beschichtet –

91904

VHM-Einzahnfräser, Spezialschliff + Beschichtung

ALUCOBOND – DLC coated –

Single flute cutters, solid carbide, special flute + coating

Art.-Nr.	A	B	C	D	E
060 688 004	4	10		60	6
070 688 004	4	10	16	70	8
070 688 005	5	10		70	8
060 688 006	6	16		60	6
070 688 006	6	10		70	8
080 688 008	8	14		80	8

91903 + 91904 für extreme Bearbeitung wie z. B. Brandschutzplatten etc.

91903 + 91904 for heavy-duty processing, for example fire-proof-sheets

Scheibenfräser HM-bestückt für ALUCOBOND

91901

für Plattensägen und-fräsen

Carbide-tipped grooving cutters for ALUCOBOND

for sheet milling machines

Art.-Nr.	A	B	C	
700 118 200	118	20	135°	Breite 18 mm
700 118 201	118	20	90°	Breite 14 mm
700 220 300	220	30	90°	Breite 14 mm
700 220 301	220	30	135°	Breite 18 mm
700 244 301	244	30	90°	Breite 14 mm
700 244 300	244	30	135°	Breite 18 mm

mit HM-Wendepplatten
with TC insert / turn-over knives

713 244 300	244	30	90°	Breite 16,5 mm
-------------	-----	----	-----	----------------

Diamant-bestückt auf Anfrage / PCD-tipped version on demand

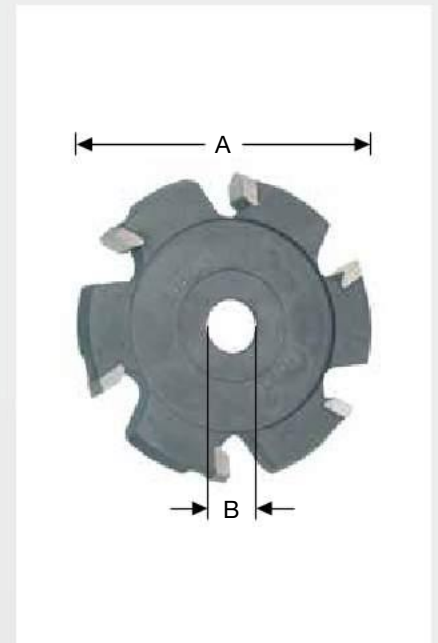

Kreissägeblätter HM-bestückt für ALUCOBOND

91902

für Plattensägen HOLZHER / Striebig

Carbide-tipped sawblades for ALUCOBOND

for sheet cutting machines HOLZHER / Striebig

Art.-Nr.	A	B	C	Z
721 250 300	250	3,2	30	60
721 300 300	300	3,2	30	72
721 300 301	300	3,2	30	96

Kreissägeblätter Diamant-bestückt
Sawblades PCD-tipped

728 300 300	300	3,2	30	72
728 300 302	300	3,2	30	96

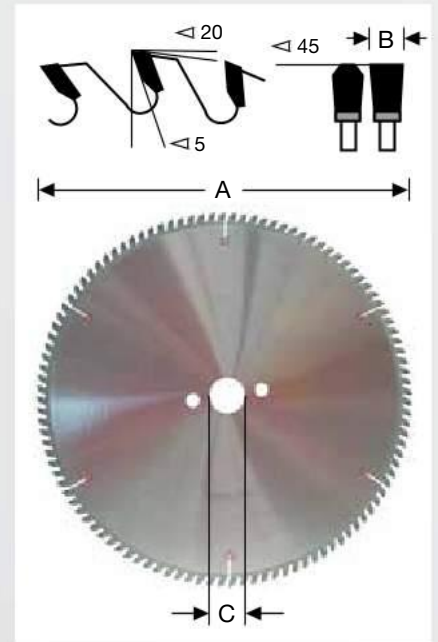

3A Kooperationspartner
COMPOSITES

ALUCOBOND®

ALUCORE®

DIBOND®

Kreissägeblätter HM-bestückt – negativ –

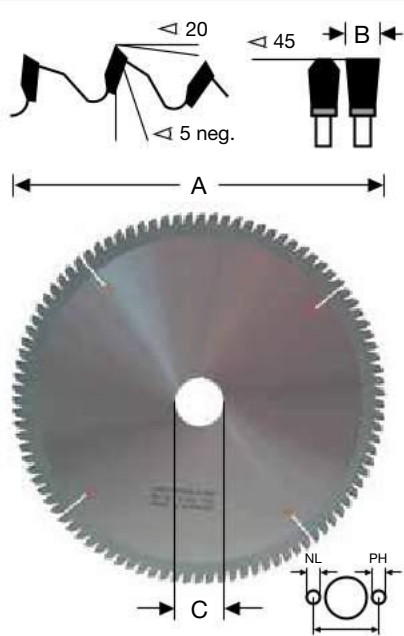

Flach-Trapez-Zahn, geräuschgedämpft

- für Profile und Vollmaterial aus Aluminium, Kunststoff und NE-Metallen
- zum Einsatz auf **Kappsägen / Zugsägen (Sägeblatt von oben)**
- weitere Abmessungen auf Anfrage

Carbide-tipped sawblades – negative rake –

TCG, noise reduced

- for profiles of aluminium and plastics
- used on **chop saws / mitre saws (sawblade feed from the top)**
- other dimensions upon demand

Art.-Nr.	A	B	C	Z	NL/ph
718 216 303	216	3,0	30	60	
718 250 300	250	3,2	30	60	
718 250 301	250	3,2	30	80	
718 250 307	250	3,2	30	120	
718 250 320	250	3,2	32	60	
718 250 321	250	3,2	32	80	
718 250 322	250	3,2	32	96	
718 260 300	260	2,4	30	68	
718 280 320	280	3,2	32	96	
718 300 300	300	3,2	30	72	
718 300 301	300	3,2	30	96	
718 300 302	300	3,2	30	120	
718 300 320	300	3,2	32	72	
718 300 321	300	3,2	32	96	
718 300 324	300	3,2	32	120	
718 300 401	300	3,2	40	96	
718 330 302	330	3,2	30	96	
718 330 322	330	3,2	32	96	
718 350 300	350	3,3	30	84	
718 350 301	350	3,4	30	108	
718 350 321	350	3,3	32	84	
718 350 320	350	3,4	32	108	
718 350 400	350	3,3	40	84	4/12/64 + 2/9/55
718 350 401	350	3,4	40	108	4/12/64 + 2/9/55
718 380 320	380	3,8	32	110	
718 380 322	380	3,8	32	84	
718 380 323	380	3,8	32	120	
718 400 302	400	3,8	30	66	
718 400 300	400	3,6	30	96	
718 400 304	400	3,6	30	120	
718 400 301	400	3,8	30	108	
718 400 320	400	3,6	32	96	2/11/63
718 400 321	400	3,6	32	120	2/11/63
718 400 400	400	3,6	40	96	4/12/64 + 2/9/55
718 420 300	420	4,0	30	96	
718 420 301	420	4,0	30	108	
718 420 303	420	4,0	30	120	
718 420 400	420	4,0	40	96	
718 420 401	420	4,0	40	108	
718 450 301	450	4,0	30	108	
718 450 320	450	3,8	32	96	
718 450 321	450	4,0	32	108	
718 475 302	475	4,0	30	96	2/14/64
718 475 301	475	4,0	30	110	2/14/64

Art.-Nr.	A	B	C	Z	NL/ph	
718 475 300	475	4,0	30	120	2/14/64	
718 500 302	500	4,0	30	120		
718 500 300	500	4,4	30	120		
718 500 303	500	4,2	30	140		
718 500 320	500	4,4	32	120		
718 520 500	520	4,4	50	120		
718 550 301	550	4,4	30	128	2/11/60	
718 550 302	550	4,4	30	132	1/10,5/60	
718 550 320	550	4,4	32	128	2/11/63	
718 550 802	550	4,0	80	160	6/9/100	
718 550 304	550	4,4	30	124		Stürtz
718 550 400	550	4,4	40	160		
718 600 300	600	4,6	30	140		
718 600 302	600	4,6	30	140		Stürtz
718 600 400	600	4,6	40	140		
718 650 401	650	4,4	40	132	2/10,5/60	
718 700 300	700	4,8	30	120	6/9/80	Stürtz
718 750 120	750	5,8	120	180	6/8,5/140	



Wussten Sie eigentlich schon,
Did you actually know,

dickwandige Profile ... weniger Zähne
dünnwandige Profile ... mehr Zähne

thick-walled extrusions ... less teeth
thin-walled extrusions ... more teeth

Kreissägeblätter HM-bestückt – positiv –

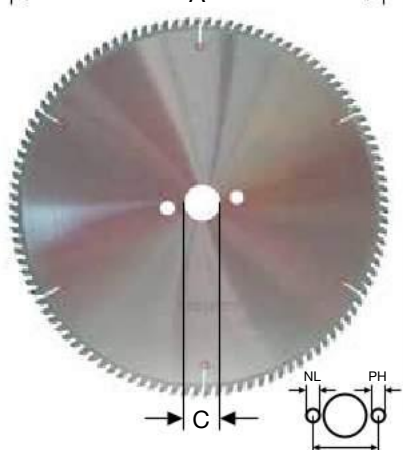
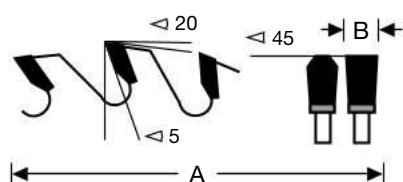

Flach-Trapez-Zahn, geräuschgedämpft

- für Profile und Vollmaterial aus Aluminium, Kunststoff und NE-Metallen
- zum Einsatz auf **Tisch- / Gehrungssägen** (Sägeblatt von unter oder Vorschub von hinten)
- weitere Abmessungen auf Anfrage

Carbide-tipped sawblades – positive rake –

TCG, noise reduced

- for profiles of aluminium and plastics
- used on **table saws / mitre saws** (sawblade feed from the bottom or from behind)
- other dimensions upon demand

Art.-Nr.	A	B	C	Z	NL/ph
720 250 300	250	3,2	30	60	
720 250 301	250	3,2	30	80	
720 250 320	250	3,2	32	60	
720 250 321	250	3,2	32	80	
720 280 322	280	3,2	32	88	
720 280 323	280	3,2	32	96	Combi
720 300 300	300	3,2	30	72	
720 300 301	300	3,2	30	96	
720 300 320	300	3,2	32	72	
720 300 321	300	3,2	32	96	
720 330 300	330	3,2	30	96	2/6,5/40
720 350 300	350	3,3	30	84	
720 350 301	350	3,4	30	108	
720 350 321	350	3,3	32	84	2/12/64
720 350 320	350	3,4	32	96	2/12/64
720 350 322	350	3,4	32	108	2/12/64
720 350 400	350	3,3	40	84	4/12/64 + 2/9/55
720 350 401	350	3,4	40	108	4/12/64 + 2/9/55
720 380 321	380	3,8	32	56	
720 400 300	400	3,8	30	96	
720 400 301	400	3,8	30	120	
720 400 320	400	3,8	32	96	2/12/64
720 400 323	400	3,6	32	120	2/12/64
720 420 301	420	4,0	30	52	
720 420 300	420	4,0	30	96	
720 420 303	420	4,0	30	120	
720 450 300	450	4,0	30	108	
720 450 321	450	3,8	32	96	2/12/64
720 450 320	450	4,0	32	108	2/12/64
720 500 306	500	4,2	30	72	
720 500 310	500	4,4	30	96	
720 500 302	500	4,0	30	120	1/10,5/30
720 500 305	500	4,0	30	120	2/10,5/70
720 500 300	500	4,4	30	120	2/11/70
720 500 309	500	4,0	30	160	2/12/64
720 500 320	500	4,0	32	120	2/12/64
720 500 322	500	4,4	32	120	2/12/64
720 500 803	500	4,0	80	140	6/9/100
720 500 805	500	3,6	80	145G5	6/9/100
720 520 300	520	4,4	30	120	
720 530 300	530	4,2	30	128	
720 550 303	550	4,4	30	72	
720 550 300	550	4,4	30	110	
720 550 304	550	4,4	30	120	2/10,5/60

Art.-Nr.	A	B	C	Z	NL/ph	
720 550 305	550	4,2	30	132		Rotox
720 550 301	550	4,4	30	132	2/10,5/70	
720 550 324	550	4,0	32	126	2/11/63	
720 550 321	550	4,4	32	132	2/12/64	
720 550 400	550	4,4	40	110	2/10,5/60	
720 550 802	550	4,0	80	160	6/9/100	
720 600 300	600	4,6	30	140		
720 600 321	600	4,6	32	140	2/12/64	
720 600 322	600	5,0	32	136	2/12/64	
720 600 400	600	4,6	40	140		
720 600 401	600	4,6	40	140	2/13/80	
720 600 500	600	4,6	50	140	2/10,5/70	
720 600 800	600	5,0	80	120	6/8/100	
720 650 300	650	5,0	30	130	2/14/64	
720 650 401	650	5,0	40	144	2/12/64	
720 650 405	650	5,0	40	144		FOM LMX
720 700 500	700	6,0	50	180		
720 750 120	750	5,7	120	180	6/8,5/140	

Schauen Sie sich unsere Sägeblätter im Einsatz auf einem LEMUTH-Bearbeitungszentrum an!



Our sawblades in use on a LEMUTH CNC machine - watch our video on YouTube!

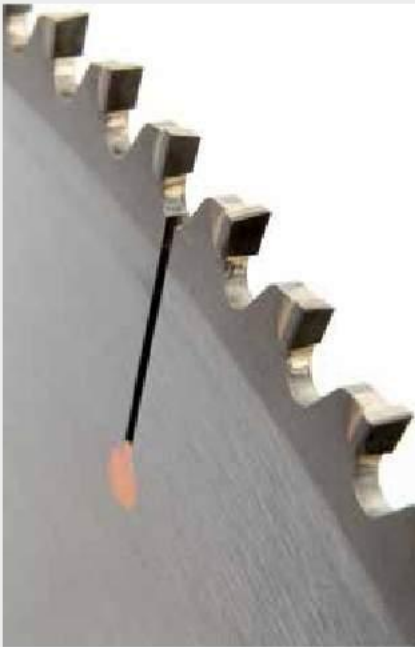

Spezial-Kreissägeblätter – Diamantbestückt –

92012

Zahnform TF auch für Alu-Bearbeitung und massive GfK-Türschwellen

- für den Zuschnitt von glasfaserverstärkten Profilen
- z.B. REHAU, aluplast, etc.
- bestmögliche Standzeit gegenüber High-tech-HM-Kreissägeblättern
- ideal für große Serien

Special sawblades – diamond-tipped –

Tooth shape TF/TCG used for aluminium and solid FIBERLINE bottom rails etc.

- for cut of glass fiber reinforced extrusions
- e.g. REHAU, aluplast, etc.
- significant better life-time against high-tech carbide blades
- for big series

Art.-Nr.	A	B	C	Z	
728 250 300	250	3,2	30	60	TF / P
728 280 320	280	3,2	32	88	TF / P
728 300 300	300	3,2	30	72	TF / P
728 300 301	300	3,2	30	96	TF / N
728 300 321	300	3,2	32	96	TF / P
728 380 320	380	3,8	32	110	TF / N
728 400 300	400	3,2	30	96	TF / P
728 420 300	420	4,0	30	96	TF / P
728 420 401	420	4,0	40	108	TF / N
728 450 301	450	4,0	30	144	TF / P
728 500 301	500	3,4	30	120	TF / P
728 500 302	500	3,4	30	96	TF / P
728 500 303	500	4,4	30	120	TF / P
728 500 800	500	4,4	80	120	TF / P
728 550 302	550	4,4	30	144	TF / P
728 550 800	550	4,0	80	160	TF / P
728 600 300	600	4,4	30	144	TF / P
728 650 400	650	4,8	40	144	TF / P



Neu im Programm / New in product range



Spezial-Kreissägeblätter – HM-bestückt –

92013

für den Zuschnitt von glasfaserverstärkten Profilen

- z.B. REHAU, aluplast, etc.
- durch Axial-Winkel auch für co-extrudierte Dichtungen
- erheblich längere Standzeit gegenüber Standard-Kreissägeblättern
- ideal für kleine und mittlere Serien

Special sawblades – carbide-tipped –

for cut of glass fiber reinforced extrusions

- e.g. REHAU, aluplast, etc.
- because of axial teeth angles also for co-extruded sealings
- significant better life-time against standard blades
- for small and medium series

Art.-Nr.	A	B	C	Z	
723 380 320	380	3,6	32	110	
723 420 300	420	3,6	30	100	
723 498 800	498	3,6	80	140	THORWESTEN - neu / new
723 500 300	500	3,6	30	140	
723 500 800	500	3,6	80	140	
723 550 300	550	4,0	30	160	
723 550 800	550	4,0	80	160	

Metallkreissägeblätter HSS

92020

DM05 dampfbehandelt

- für Stahlbearbeitung
- weitere Abmessungen auf Anfrage!

Metal cutting sawblades HSS

DM05 vaporized

- for steel cutting
- Other dimensions upon demand!

Art.-Nr.	A	B	C	Z	
702 200 321	200	1,8	32	128	
702 225 320	225	2,0	32	180	
702 250 324	250	2,0	32	160	
702 250 321	250	2,0	32	200	
702 250 322	250	2,0	32	240	
702 275 321	275	2,0	32	220	
702 275 320	275	2,5	32	220	
702 275 400	275	2,5	40	72	
702 275 405	275	2,5	40	110	
702 275 401	275	2,5	40	120	
702 275 404	275	2,5	40	140	
702 275 402	275	2,5	40	160	
702 275 403	275	2,5	40	220	
702 300 320	300	2,5	32	160	
702 300 321	300	2,5	32	220	
702 300 400	300	2,5	40	220	
702 350 321	350	2,5	32	180	
702 350 320	350	2,5	32	280	
702 400 500	400	3,5	50	80	
702 450 400	450	4,0	40	120	
702 450 401	450	3,0	40	350	
702 250 329	250	2,0	32	240	HSSE / Cobalt*
702 275 329	275	2,5	32	220	HSSE / Cobalt*
702 315 320	315	2,5	32	220	HSSE / Cobalt*
702 350 322	350	3,0	32	280	HSSE / Cobalt*
702 350 323	350	3,0	32	350	HSSE / Cobalt*

* Kobalt für Edelstahl / Cobalt for stainless steel

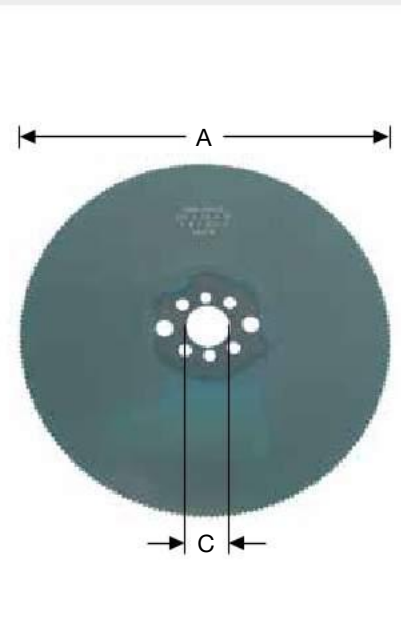

Metallkreissägeblätter

92021

für Isolierglasfertigung

Metal cutting sawblades

for spacer bars

Art.-Nr.	A	B	C	Z	
702 160 320	160	1,0	32	160	HSS
770 160 324	160	1,0	32	160	VHM / solid carbide
770 160 320	160	1,6	32	160	VHM / solid carbide
702 200 325	200	1,0	32	200	HSS
702 200 326	200	1,0	32,	350	HSS
702 200 329	200	1,0 / 0,5	32	350	HSS

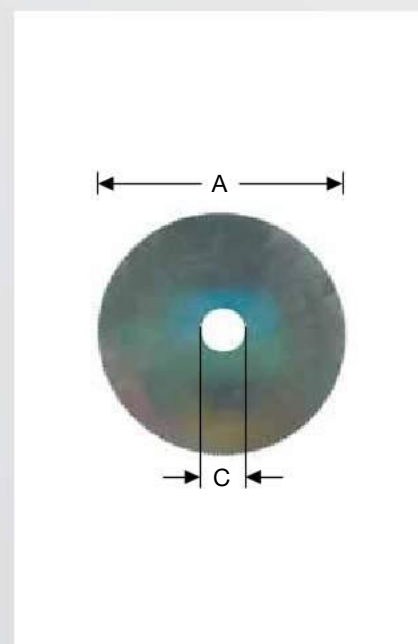

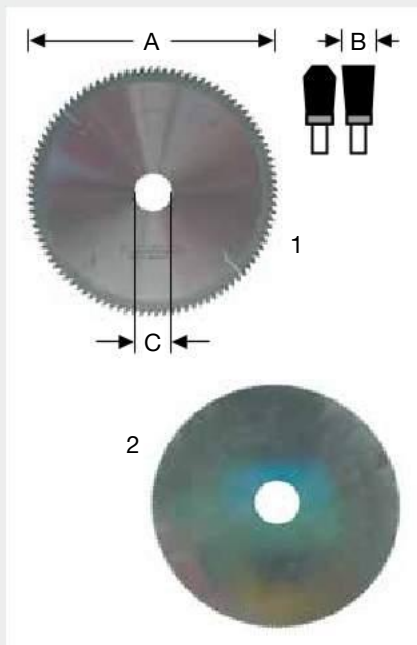

Glasleisten-Sägeblätter

92030

für elumatec, Haffner, Rotox, Striffler, Wegoma, etc.

- 1 = HM-bestückt - 2 = HSS Spezial

- * W = Wechselzahn

Glazing bead sawblades

for elumatec, Haffner, Rotox, Striffler, Wegoma, etc.

- 1 = carbide-tipped - 2 = HSS special

- * at = alternate teeth

Art.-Nr.	A	B	C	Z	Bild / pic.
720 160 200	160	2,5	20	48	1
720 175 200	175	2,1	20	68	1 W/at*
720 200 201	200	2,1	20	60	1 W/at*
718 200 301	200	2,2	30	100	1
720 200 320	200	2,5	32	80	1
718 200 321	200	2,2	32	100	1
702 200 320	200	2,0	32	180	2
718 225 320	225	2,0	32	100	1
702 225 321	225	2,0	32	200	2
718 250 200	250	2,2	20	120	1 W/at*
702 250 200	250	2,0	20	180	2
702 250 325	250	2,0	32	180	2
720 300 302	300	2,4	30	96	1
720 300 305	300	3,2	30	120	1 W/at*
720 300 306	300	2,2	30	120	1

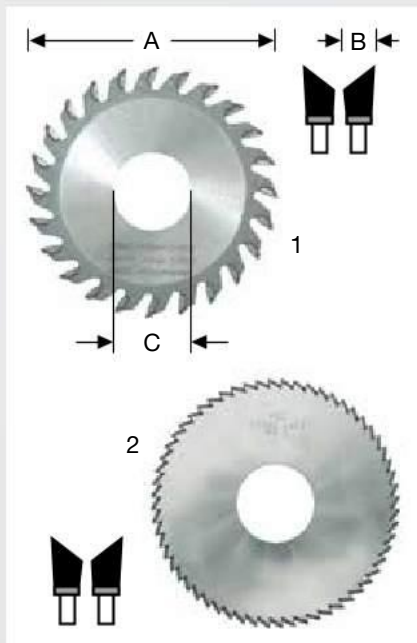

Glasleisten-Sägeblätter 45°

92031

passend zu 92030

- 1 = HM-bestückt - 2 = HSS Spezial

- R = Rechts - L = Links

Glazing bead sawblades 45°

fits to 92030

- 1 = carbide tipped - 2 = HSS special

- R = RH - L = LH

Art.-Nr.	A	B	C	Z	Bild / pic.
718 092 300	92	3,0	30	24	1 R
718 092 301	92	3,0	30	24	1 L
720 095 200	95	2,1	20	20	1 R
720 095 201	95	2,1	20	20	1 L
702 098 320	98	2,0	32	60	2 R
702 098 321	98	2,0	32	60	2 L
720 098 320	98	3,0	32	36	1 R
720 098 321	98	3,0	32	36	1 L
720 103 320	103	2,1	32	24	1 R
720 103 321	103	2,1	32	24	1 L
702 103 320	103	2,1	32	60	2 R
702 103 321	103	2,1	32	60	2 L
702 103 322	103	2,1	32	100	2 R
702 103 323	103	2,1	32	100	2 L
720 150 300	150	4,0	30	32	1 R
720 150 301	150	4,0	30	32	1 L

für Klinkschnitt-Sägen

- und Bearbeitungszentren: elumatec, Graule, Pressta-Eisele, Rotox, Schüco, etc.

Carbide-tipped sawblades for endmilling machines

for Vee-notching saws

- and CNC-machining-centres: elumatec, Graule, Pressta Eisele, Rotox, Schüco, etc.

Art.-Nr.	A	B	C	Z		für Halter / for holder	
700 092 330	92	3,0	16	14	2	elumatec	(A)
700 092 331	92	4,0	16	14	2	elumatec	(A)
700 092 334	92	6,0	16	14	2	elumatec	(A)
700 092 445	92	10,0	16	14	2	elumatec	(A)
700 092 333	92	15,0	16	14	2	elumatec	(A)
700 092 449	92	20,0	16	14	2	elumatec	(A)
700 120 300	120	5,7	30	30	1	Schüco	
700 130 160	130	6,0	16	18	2	elumatec	(A)
700 160 300	160	5,7	30	36	2	BDM	(A)
700 180 200	180	3,5	20	34	1	elumatec	(A)
700 180 201	180	4,5	20	56	2	Emmegi	(A)
700 180 320	180	3,2	32	28	3	elumatec	(A)
700 250 320	250	3,2	32	80	1	Emmegi	(A)
720 254 322	254	3,4	32	100	1		
720 300 322	300	3,4	32	104	1		
700 300 321	300	3,6	32	84	1	Emmegi	(A)
700 340 320	340	3,6	32	96	2	Emmegi	(A)
700 350 401	350	3,4	40	96	2		
700 350 402	350	3,5	40	108	2		
700 380 400	380	3,8	40	110	1		
700 400 320	400	4,6	32	96	1	elumatec	(A)
700 400 402	400	4,0	40	96	3	bavius	(A)
700 400 500	400	3,8	50	96	2		
700 450 402	450	4,0	40	108	2		
700 500 300	500	4,4	30	120	1		
700 500 320	500	4,6	32	120	1	elumatec	(A)
700 500 321	500	4,6	32	60	1	elumatec	(A)
700 500 325	500	4,5	32	120	1	Emmegi	(A)
700 500 402	500	4,0	40	120	1	FOM	(A)
700 500 500	500	4,4	50	120	1		
700 550 400	550	4,4	40	110	1		
700 550 500	550	4,4	50	110	1		
700 550 501	550	4,4	50	132	2		
700 600 320	600	5,0	32	136	2		
700 650 400	650	5,0	40	140	3		
700 650 500	650	4,4	50	144	2		

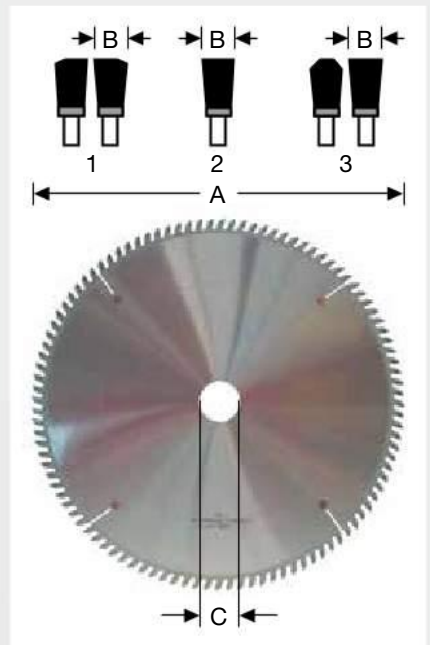

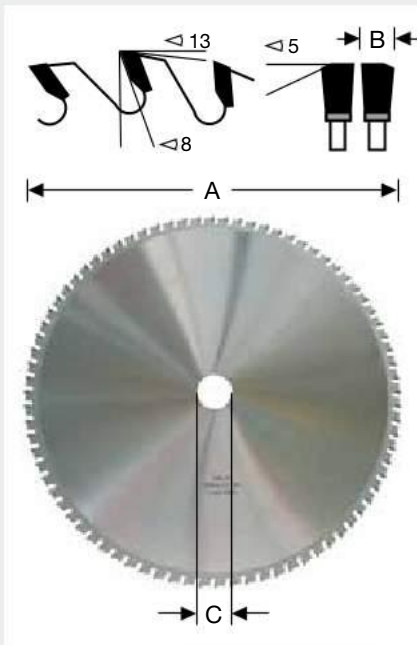

Stahl-Kreissägeblätter HM-bestückt

92041

für Trockenschnitt, Spezialzahn

- zum Trennen von Weichstahl, Metallverkleidungen, Flach- und Winkelisen, Rohre, Kabelkanäle, Bleche, Messing, Kupfer, Aluminium etc.

Carbide-tipped steel-circular sawblades

for dry-cutting, special teeth

- for cutting mild-steel, metal-clad workpieces, sandwich panels, angle irons, pipes, cable ducts, sheet metal, brass, copper, aluminium, etc.

Art.-Nr.	A	B	C	Z
707 160 200	160	2,2	20	30
707 190 301	190	2,4	30	38
707 190 302	190	2,2	30	48
707 200 300	200	2,4	30	40
707 210 302	210	2,4	30	40
707 216 300	216	2,4	30	40
707 230 301	230	2,4	30	44
707 250 300	250	2,4	30	48
707 300 300	300	2,4	30	60
707 300 301	300	2,4	30	80
707 305 257	305	2,4	25,4	60
707 305 254	305	2,4	25,4	80
707 350 255	350	2,4	25,4	72
707 350 300	350	2,6	30	80
707 355 256	355	2,6	25,4	90
707 355 301	355	2,4	30	90
707 400 300	400	3,0	30	84

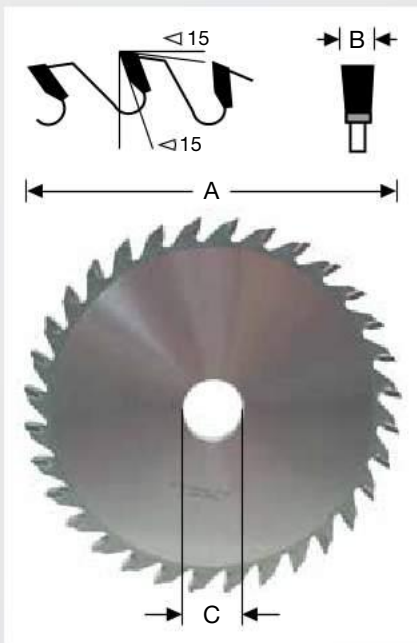

Auslinkfräser – Hartmetallbestückt –

92050

einsetzbar in Maschinen von:

elumatec, Graule, Haffner, Pressta-Eisele, Rotox, Schüco, Wegoma, etc.

Carbide-tipped endmilling cutters

for endmilling machines

elumatec, Graule, Haffner, Pressta-Eisele, Rotox, Schüco, Wegoma, etc.

Art.-Nr.	A	B	C	Z
700 125 300	125	8,0	30	12
700 150 300	150	8,0	30	12
700 150 321	150	8,0	32	12
700 200 403	200	8,0	40	32
700 250 406	250	8,0	40	40
700 250 403	250	10,0	40	32
700 280 401	280	8,0	40	36
700 300 400	300	8,0	40	36

zum Bearbeiten der Aussenkontur

- auf CNC-Verputzmaschinen wie elumatec, Rotox, Stürtz, Urban, Wegoma, etc.

Carbide-tipped sawblades

Disk cutters for machining outer profile corners

- used on CNC-corner cleaners as elumatec, Rotox, Stürtz, Urban, Wegoma, etc.

Art.-Nr.	A	B	C	Z	Bild / pic.
473 817 450	170	4,5	20	12+4 R	2
473 817 460	170	4,5	20	12+4 L	2
473 819 450	190	4,5	20	16+4 R	2
473 819 460	190	4,5	20	16+4 L	2
700 200 300	200	3,0	30	48	1
700 225 300	225	3,6	30	54	3
700 230 200	230	4,5	20	54+6	2
700 230 328	230	3,0	30	60	2
700 230 300	230	3,0	30	60	1
700 250 201	250	4,5	20	68+5	2
700 250 329	250	3,3	30	54	1
700 250 328	250	3,3	32	54	1
700 250 326	250	5,0	32	32	2 10 mm
700 250 325	250	5,0	32	32	2 17 mm
700 250 324	250	5,0	32	63+5	2
700 250 399	250	5,0	30	8+12+12	2
700 300 200	300	5,0	25	90+6	2

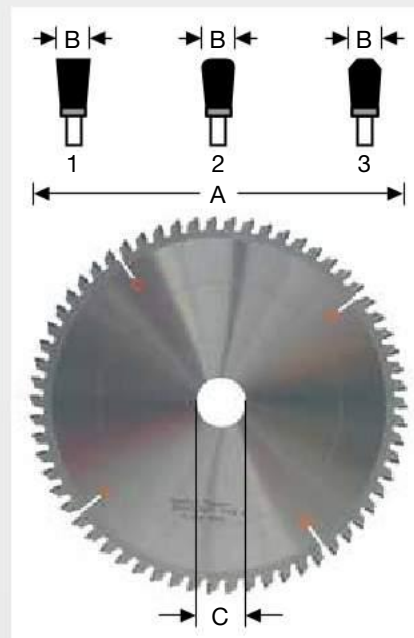

Kreissägeblätter HM-bestückt „SAMURAI“



Dünnschnitt-Sägeblätter

- Flach-Trapez-Zahn, geräuschgedämpft,
- für Profile aus Aluminium, Kunststoff und NE-Metallen
- Hervorragende Standzeit und Schnittqualität durch spezielles Stammblatt (Japan-Stahl) und geringem Schnittdruck
- durch Dünnschnitt-Technologie erhöhte Material-Ausbeute, dadurch reduzierte Entsorgungskosten

Carbide-Tipped sawblades „SAMURAI“

Thin sawing technology

- Triple-chip grinding, noise-reduced
- for profiles / extrusions of aluminium and plastics
- significant better life-time and cut quality because of special steelbody (japan steel) and less cutting forces

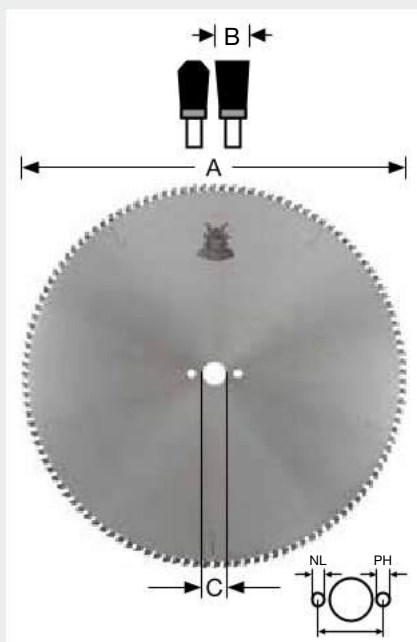

Art.-Nr.	A	B	C	Z	NL/ph
729 350 320	350	2,8	32	108 +5°	2-Ø 12/64
729 350 321	350	2,8	32	108 -5°	2-Ø 12/64
729 400 320	400	2,8	32	96 +5°	2-Ø 12/64
729 400 321	400	2,8	32	96 -5°	2-Ø 12/64
729 420 300	420	2,8	30	96 +5°	2-Ø 11/70
729 420 320	420	2,8	32	96 +5°	2-Ø 12/64
729 500 300	500	3,0	30	120 +5°	2-Ø 11/60
729 500 320	500	3,0	32	120 +5°	2-Ø 14/64
729 550 300	550	3,0	30	132 +5°	2-Ø 10/60
729 550 320	550	3,0	32	132 +5°	2-Ø 12/64
729 550 800	550	3,0	80	132 +5°	6-Ø 9/100
729 550 801	550	3,0	80	132 +10°	6-Ø 9/100
729 600 300	600	3,0	30	140 +5°	2-Ø 14/64
729 600 320	600	3,0	32	140 +5°	2-Ø 12/64
729 600 400	600	3,0	40	140 +5°	2-Ø 13/80

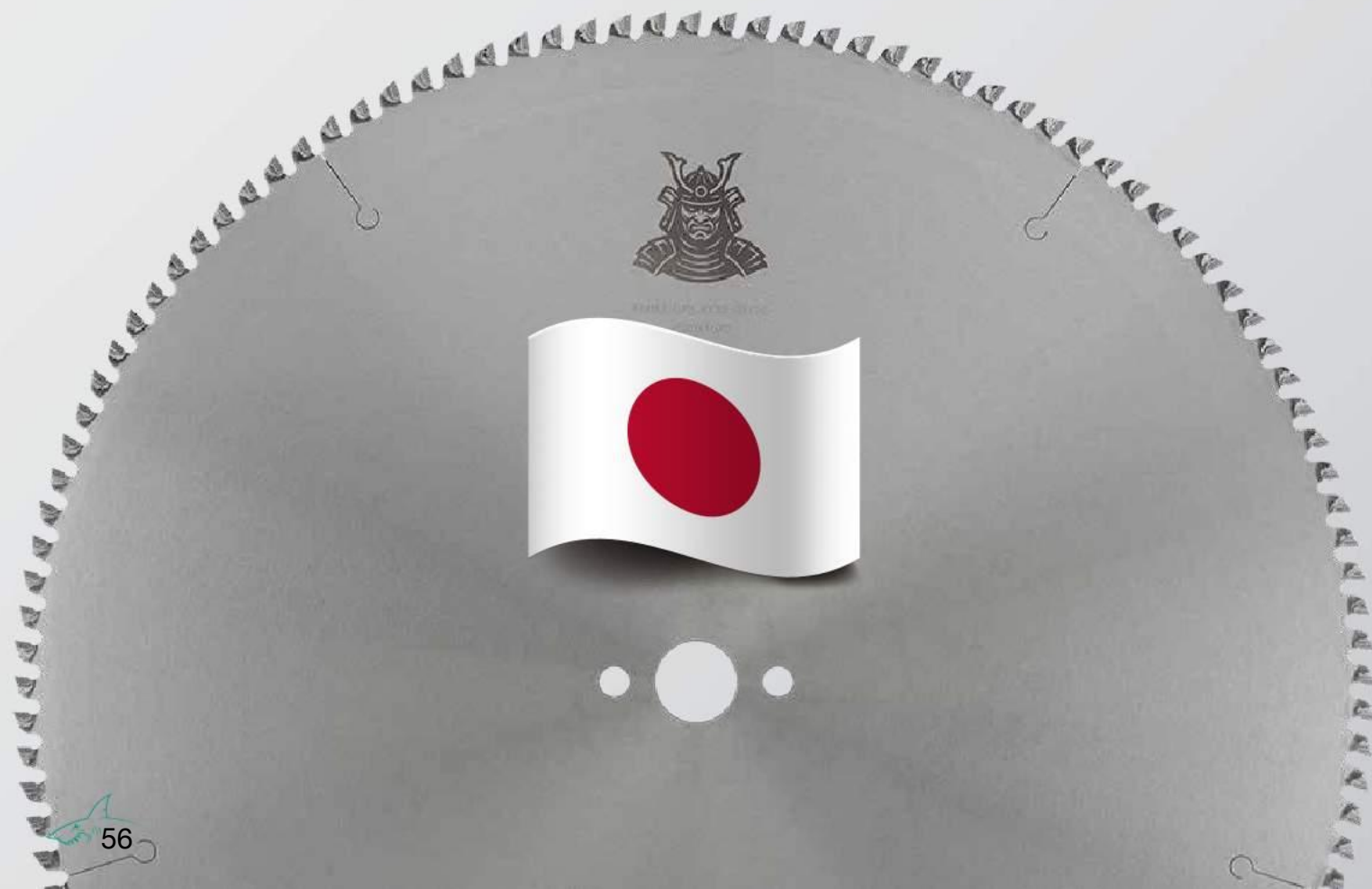

Wichtige Anwendungstipps

Um bei der Bearbeitung Ihrer Werkstücke optimale Einstellwerte / Betriebsparameter zu finden, spielen eine Vielzahl von Faktoren eine Rolle:

- Material des Werkstückes
- Materialspannung auf der Maschine
- Art der Kühlung / Schmierung
- Leistung / max. Drehzahl der Spindel
- Verfahrgeschwindigkeit der Maschine
- Stabilität / Steifigkeit der Maschine

Angesichts dieser Vielzahl an Parametern die ineinanderwirken, ist es nicht möglich allgemeingültige Einstellwerte zu liefern.

Dies muss von Fall zu Fall angepasst und optimiert werden.

Wir informieren Sie gerne über unsere erfahrungsgemäßen Richtwerte.

Tips for proper use

In order to set the optimal values for your machine a number of factors are important:

- what kind of material workpiece made of*
- material clamping on the machine*
- type of coolant / lubricant*
- power / speed rate of spindle motor*
- feed rate*
- stiffness of machine*

As there is a large number of parameters which influence each other, it is not possible to provide you with generalities concerning machine parameters.

Instead we will be glad to inform you about our experience-based reference values.





Kühlmittelkonzentrat

93000

biologisch abbaubar, wassermischbar – Alte Version, auslaufend –

- Mischungsverhältnis: 1:20
- verwendbar für Aluminium und Stahl auf Kopierfräsmaschinen, Wasserschlitzfräsmaschinen, NE-Sägemaschinen, etc.

Coolant concentrate

free from environment polluting substances, water mix – old version, discontinued –

- mixing proportion: 1:20
- used for aluminium and steel on copy-router machines, waterslot machines, sawing machines etc.

Art.-Nr.

600 000 005	5 Liter Kanister / canister
600 000 020	20 Liter Kanister / canister
600 000 200	208 Liter Fass / drum



Kühlmittelkonzentrat

93001

für Stahlbearbeitung

- Mischungsverhältnis 1:10
- verwendbar in: Sägemaschinen / Umlaufkühlung für Stahlbearbeitung

Coolant concentrate

for steel working

- mixing proportion 1:10
- used in: steel sawing machines

Art.-Nr.

601 000 005	5 Liter Kanister / canister
601 000 020	20 Liter Kanister / canister



Hochleistungs-Kühlschmiermittel

93010

für Impuls-Sprüheinrichtungen

- verwendbar in z. B. elumatec, Pressta-Eisele, Emmegi, FOM, Mecal, etc.

High-duty coolant liquid

for cycle mist spray units

- used in e. g. elumatec, Pressta-Eisele, Emmegi, FOM, Mecal, etc.

Art.-Nr.

604 000 001	1 Liter Flasche / bottle
604 000 005	5 Liter Kanister / canister
604 000 020	20 Liter Kanister / canister
604 000 200	208 Liter Fass / drum

Hochleistungs-Kühlschmiermittel

93011

- reizarm, für Impuls-Sprüheinrichtungen
- verwendbar in z.B. elumatec, Pressta-Eisele, Emmegi, etc.

High-duty coolant liquid

- *no skin irritation, for cycle mist spray units*
- *used in e.g. elumatec, Pressta-Eisele, Emmegi, etc.*

Art.-Nr.

604 001 001	1 Liter Flasche / bottle
604 001 005	5 Liter Kanister / canister
604 001 020	20 Liter Kanister/ canister



Kühlschmiermittel EMMEGI P68

93016

speziell abgestimmt auf EMMEGI-Maschinen wie z.B. QUADRA, SATELLITE, etc.

Coolant liquid EMMEGI P68

special designed for pulsed spray coolant system EMMEGI QUADRA, SATELLITE, etc.

Art.-Nr.

607 000 005	5 Liter Kanister / canister
607 000 020	20 Liter Kanister/ canister
607 000 200	208 Liter Fass / drum



Hochleistungs-Kühlschmiermittel

93017

sehr dünnflüssig, schnell verdunstend, rückstandsfrei
für Impuls-Sprüheinrichtungen
- verwendbar in z.B. elumatec, Pressta-Eisele, Emmegi, FOM, Mecal, etc.

High-duty coolant liquid

*with low viscosity and fast exhale, residue-free,
for cycle mist spray units*
- *used in e.g. elumatec, Pressta-Eisele, Emmegi, FOM, Mecal, etc.*

Art.-Nr.

608 000 005	5 Liter Kanister / canister
608 000 020	20 Liter Kanister / canister
608 000 200	208 Liter Fass / drum





Hochleistungs-Kühlschmiermittel

93018

speziell für schwere Alu-Bearbeitung, z. B. dickwandige Profile

- dünnflüssig und schnell verdunstend
- nahezu rückstandsfrei
- verwendbar in Impuls-Sprüheinrichtungen, z. B. elumatec, Emmegi, FOM, Mecal, Pressta-Eisele etc.



High-duty coolant liquid

Special for heavy duty cutting of thick-wall aluminium extrusions

- with low viscosity and fast exhale
- nearly residue-free
- used in cycle mist spray units e.g. elumatec, Emmegi, FOM, Mecal, Pressta-Eisele, etc.

Art.-Nr.

608 001 005 5 Liter Kanister / canister

608 001 020 20 Liter Kanister / canister

608 001 200 208 Liter Fass / drum



Hochleistungs-Kühlschmiermittel – BioCut –

93019

Biologisch abbaubar, auf Basis nachwachsender Rohstoffe, für Impuls-Sprüheinrichtungen

- verwendbar in z.B. elumatec, Pressta-Eisele, Emmegi, FOM, Mecal, etc.



High-duty coolant liquid – BioCut –

Biodegradable, based on renewable resources, for cycle mist spray units

- used in e.g. elumatec, Pressta-Eisele, Emmegi, FOM, Mecal, etc.

Art.-Nr.

605 000 001 1 Liter Flasche / bottle

605 000 005 5 Liter Kanister / canister

605 000 020 20 Liter Kanister / canister

605 000 200 208 Liter Fass / drum



Schneidöl-EP-Spray

93021

verschleißmindernd und außerordentliche Schmierfilmfestigkeit

- Hochleistungsschneidöl mit EP-Zusätzen
- chlor- silikon- und wachsfrei

Cutting oil spray

abrasive wear and best possible lubricating oil film

- High-duty cutting oil with EP (Extreme-Pressure) additives
- free of chlorine-silicon-wax

Art.-Nr.

602 000 400 400 ml

Kleber für Dichtungsprofile

93200

- Stoßfugen und Gehrungsschnitte an Fensterdichtungen schnell, sicher und dauerhaft verkleben
- VE = 10 Flaschen

Special glue for sealings

- to glue window seals at the cut surface.
- Box = 10 bottles

Art.-Nr.

900 000 631	20 g
900 000 632	50 g



Schneidöl für Glas – WEMACUT –

93202

Universell einsetzbar für den Zuschnitt von Floatglass/Isolierglas, Automobil- und Spiegelglas

- Zuschnitt bis 10 mm
- schnellverdunstend, keine Rückstände
- Bindung kleiner Glaspartikel
- für alle gängigen Maschinen wie z.B. Bavelloni, Bohle, Bottero, Bystronic, Hegla, Lisec usw. und alle Handschneider



Cutting liquid for glass – WEMACUT–

Universal applicable for cutting insulating glass, automotive- and mirror glass

- for thickness up to 10 mm
- fast evaporating, residue
- binding small glass particles
- for all kind of glass cutting machines as brands Bavelloni, Bohle, Bottero, Bystronic, Hegla, Lisec etc. and all manual oil glass cutters

Art.-Nr.

600 005 502	5 Liter Kanister / canister
600 005 503	20 Liter Kanister / canister
600 005 504	208 Liter Fass / drum





Spannzangen

94000

- passend zu Elu MOF 77 / 131 / 177, ROTOX KF - Serie 1, elumatec Bohreinheiten, elumatec AS 70 AS 170 / GF 171 / KF178 / SBZ 122

Collets

- suitable to Elu MOF 77 / 131 / 177, ROTOX KF - Serie 1, elumatec Bohreinheiten, elumatec AS 70 AS 170 / GF 171 / KF178 / SBZ 122

Art.-Nr.	A	B	C
077 351 030	3,0	19,6	34,2
077 351 040	4,0	19,6	34,2
077 351 050	5,0	19,6	34,2
077 351 060	6,0	19,6	34,2
077 351 063	6,35	19,6	34,2
077 351 070	7,0	19,6	34,2
077 351 080	8,0	19,6	34,2
077 351 090	9,0	19,6	34,2
077 351 095	9,52	19,6	34,2
077 351 100	10,0	19,6	34,2
077 351 120	12,0	19,6	34,2
077 351 127	12,7	19,6	34,2

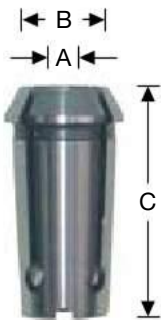

Spannzangen

94001

- passend zu Elu MOF 96, Wegoma OF, Perles OF, ROTOX Wasserschlitzfräsen

Collets

- suitable to Elu MOF 96, Wegoma OF, Perles OF, ROTOX Water slot machines

Art.-Nr.	A	B	C
053 351 005	6,0	13,5	26,0
053 351 006	6,35	13,5	26,0
053 351 004	8,0	13,5	26,0

Spannzangen

94002

- passend zu elumatec AS70, KF78, Haffner

Collets

- suitable to elumatec AS70, KF78, Haffner

Art.-Nr.	A	B	C			
070 351 000	8,0	70,2	M8			
900 000 171	8,0	69,0	M10	MK2	Haffner	MLA
078 351 000	10,0	70,2	M8			
900 000 172	10,0	69,0	M10	MK2	Haffner	MLA



Spannzangen

94003

- passend zu elumatec Haffner, Wegoma KF

Collets

- suitable to Haffner, Wegoma KF

Art.-Nr.	A	B	C			
900 000 016	5,0	16,9	33,0			
900 000 017	6,0	16,9	33,0			
900 000 095	6,35	16,9	33,0			
900 000 018	8,0	16,9	33,0			
900 000 019	10,0	16,9	33,0			



Spannzangen

94004

- passend zu Pertici Kopierfräsen

Collets

- suitable to Pertici copy routers

Art.-Nr.	A	B	C			
900 000 054	6,0	15	30,3			
900 000 031	8,0	15	30,3			
900 000 033	10,0	15	30,3			





Spannzangen

94005

- passend zu ROTOX KF ab Serie 2

Collets

- suitable to ROTOX KF up from series 2

Art.-Nr.	A	B	C
900 000 021	6,0	15,6	34,5
900 000 022	8,0	15,6	34,5
900 000 023	10,0	15,6	34,5



Spannzangen

94006

- passend zu elumatec SBZ 130 / 140 / 150, SKL 118, ALTECH, Emmegi, TEKNA

Collets

- suitable to elumatec SBZ 130 / 140 / 150, SKL 118, ALTECH, Emmegi, TEKNA

Art.-Nr.	A	B	C
130 351 006	3,0-4,0	33,0	40,2
130 351 005	4,0-5,0	33,0	40,2
130 351 007	5,0-6,0	33,0	40,2
130 351 008	6,0-7,0	33,0	40,2
130 351 000	7,0-8,0	33,0	40,2
130 351 026	8,0-9,0	33,0	40,2
130 351 001	9,0-10,0	33,0	40,2
130 351 027	10,0-11,0	33,0	40,2
130 351 002	11,0-12,0	33,0	40,2
130 351 028	12,0-13,0	33,0	40,2
130 351 029	13,0-14,0	33,0	40,2
130 351 003	15,0-16,0	33,0	40,2
130 351 004	19,0-20,0	33,0	40,2

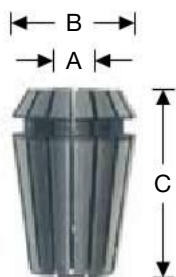

Spannzangen

94007

- passend zu passend zu: Pressta-Eisele KF, Emmegi, FOM, elumatec

Collets

- suitable to Pressta-Eisele KF, Emmegi, FOM, elumatec

Art.-Nr.	A	B	C
900 000 175	3,0	21,0	31,5
900 000 176	4,0	21,0	31,5
900 000 178	5,0	21,0	31,5
900 000 073	6,0	21,0	31,5
900 000 074	8,0	21,0	31,5
900 000 075	10,0	21,0	31,5
900 000 170	12,0	21,0	31,5

Spannzangen

94008

- passend zu elumatec SBZ Type 122, EMMEGI, Pressta CopyS, Rotox AKF, Schüco

Collets

- suitable to elumatec SBZ Type 122, EMMEGI, Pressta CopyS, Rotox AKF, Schüco

Art.-Nr.	A	B	C
122 351 010	0,5-1,0	16,8	28
122 351 015	1,0-1,5	16,8	28
122 351 020	1,5-2,0	16,8	28
122 351 025	2,0-2,5	16,8	28
122 351 030	2,5-3,0	16,8	28
122 351 040	3,0-4,0	16,8	28
122 351 050	4,0-5,0	16,8	28
122 351 060	5,0-6,0	16,8	28
122 351 070	6,0-7,0	16,8	28
122 351 080	7,0-8,0	16,8	28
122 351 090	8,0-9,0	16,8	28
122 351 000	9,0-10,0	16,8	28



Spannzangen

94012

- passend zu elumatec BZ, EMMEGI, Thorwesten

Collets

- suitable to elumatec BZ, EMMEGI, Thorwesten

Art.-Nr.	A	B	C
900 000 504	3,0-4,0	25,7	34
900 000 505	4,0 - 5,0	25,7	34
900 000 506	5,0-6,0	25,7	34
900 000 507	6,0-7,0	25,7	34
900 000 508	7,0-8,0	25,7	34
900 000 509	8,0-9,0	25,7	34
900 000 510	9,0-10,0	25,7	34
900 000 511	10,0-11,0	25,7	34
900 000 512	11,0-12,0	25,7	34



Spannzangen

94014

- passend zu elumatec SBZ 610, Haffner

- weitere Abmessungen auf Anfrage

Collets

- suitable to elumatec SBZ 610, Haffner

- other dimensions upon demand

Art.-Nr.	A	B	C
610 351 003	5,0	19,8	33
610 351 004	6,0	19,8	33
610 351 001	8,0	19,8	33
610 351 000	10,0	19,8	33
610 351 012	12,0	19,8	33



Spannzangen

94015

- passend für Mehrspindel-Bohrköpfe mit Anzugsgewinde M8x0,75 mm

Collets

- suitable for Multi-spindle drills heads with male thread M8x0,75 mm



Spannzangen

94018

- Typ ER 40

Collets

- type ER 40



Spannmuttern

94009

A = Bild
B = passend zu

Collet nuts

A = picture
B = suitable for



Art.-Nr.	A	B	Spannschlüssel / wrench
053 107 400	1	94001	
077 107 400	2	94000	
112 122 402	2	94000	
122 107 400	3	94008	122 351 888
122 107 401	7/Mini	94008	122 351 666
900 000 024	4	94005	
900 000 020	5	94003	
900 000 068	6	94004	
900 000 076	7	94007	900 000 888
900 352 100	7	94012	900 352 888
130 352 100	8	94006	130 351 888
610 352 100	7	94014	

Hand-Entgratmesser

95000

zur manuellen Bearbeitung von Schweißraupen an Kunststoff-Fenstern
- Messerführung hierzu auf Anfrage

Moon knives

used to remove welding sprue from UPVC-windows
- Button stick on request

Art.-Nr.			Bild / pic.
900 000 202	Economy		1
900 000 010	Original / Genuine	Don Carlos	2



Hand-Abstechmesser

95001

- mit Handgriff, gebogen 110mm

Groove knife

- with Handles, curved 110 mm

Art.-Nr.
900 000 121





Präzisions-Spannzangenfutter

94016

für CNC Bearbeitungszentren wie Biesse, elumatec, Emmegi, FOM, Italmac, Mecal, SMC, etc.

C = passende Spannzangen zu

Precision collet chucks

suitable for CNC machining centres as Biesse, elumatec, Emmegi, FOM, Italmac, Mecal, SMC, etc.

C = suitable collets

Art.-Nr.	A	B	C	D	Bild / pic.	
118 350 803	70	27	94000	C50/63	2	SLK118
118 350 809	75	47	94006	C50/63	2	SLK118 - neu -
136 350 855	76	60	94019	HSK50F	1	
136 350 813	63	25	94000	HSK63F	2	
136 350 817	67	47	94006	HSK63F	1	
136 350 840	70	43	94012	HSK63F	1	
136 350 852	70	50	94006	HSK63F	1	
136 350 853	76	60	94019	HSK63F	1	
136 350 854	76	63	94018	HSK63F	1	
136 350 818	98	25	94000	HSK63F	2	
136 350 851	100	43	94012	HSK63F	1	
136 350 862	100	63	94006	HSK63F	1	
136 350 812	142	25	94000	HSK63F	2	
136 350 856	60	50	94006	HSK40E	1	
136 350 857	63	50	94006	SK40	1	
136 350 858	50	50	94006	SK30	1	
136 350 864	80	22	94008	SK30	2	FOM
136 350 859	55	50	94006	ISO30	1	
136 350 860	70	63	94018	ISO30	1	
628 350 801	70	50	94006	HSKC40	1	
628 350 802	55	35	94007	HSKC40	1	

Präzisions-Bohrfutter

94017

für CNC Bearbeitungszentren wie Biesse, elumatec, Emmegi, FOM, Italmac, Mecal, SMC, etc.

Precision drill chucks

suitable for CNC machining centres as Biesse, elumatec, Emmegi, FOM, Italmac, Mecal, SMC, etc.

Art.-Nr.	A	B	C	D
136 350 801	97	57	3-16	HSK63F
136 350 800	115	45	1-10	HSK63F
130 350 800	90	50	1-13	SK30
130 350 803	90	50	1-13	SK40

Präzisions-Spannzangenfutter SUPERSPEED

94019

für CNC Bearbeitungszentren wie elumatec, Emmegi, Schirmer etc.

C = passende Spannzangen

- feingewuchtet bis 36.000 u/min
- deutlich erhöhte Lebensdauer der Spindeln durch extreme und nahezu vibrationslose Laufruhe
- patentiertes ZETA Spansystem, innenliegend mit exakter und enormer Spannkraft

Precision collet chucks SUPERSPEED

suitable for CNC machining centres as elumatec, Emmegi, Schirmer, etc.

C = suitable collets

- precision balanced up to 36.000 rpm
(low turbulent sound damping and less vibrations resulting in increased spindle life)
- due to extremely smooth and virtually vibration-free running
- patented ZETA safety collet nut (with precise and powerful clamping force)

Art.-Nr.	A	B	C	D	Bild / pic.
143 516 060	60	29	94008	HSK63F	1
143 516 076	76	29	94008	HSK63F	1
143 516 100	100	29	94008	HSK63F	1
143 516 125	125	29	94008	HSK63F	1
143 516 150	150	29	94008	HSK63F	1
143 525 076	76	37	94012	HSK63F	1
143 525 100	100	37	94012	HSK63F	1
143 525 125	125	37	94012	HSK63F	1
143 525 150	150	37	94012	HSK63F	1
143 532 115	115	48	94006	HSK63F	2
143 532 125	125	48	94006	HSK63F	2
143 532 150	150	48	94006	HSK63F	2
143 532 180	180	48	94006	HSK63F	2
143 532 200	200	48	94006	HSK63F	2



Zubehör / Accessories

Art.-Nr.	Beschreibung/Description	Bild / pic.
143 353 888	Montagevorrichtung HSK63 Assembly device HSK63	3
143 353 999	Drehmomentschlüssel Torque wrench	
143 353 116	Stecknuss / Adapter 16 ZETA Torque-nut / Adapter 16 ZETA	3
143 353 125	Stecknuss / Adapter 25 ZETA Torque-nut / Adapter 25 ZETA	3
143 353 132	Stecknuss / Adapter 32 ZETA Torque-nut / Adapter 32 ZETA	3
143 353 016	Spannschlüssel 16 ZETA Spanner wrench 16 ZETA	3
143 353 025	Spannschlüssel 25 ZETA Spanner wrench 25 ZETA	3
143 353 032	Spannschlüssel 32 ZETA Spanner wrench 32 ZETA	3



Sichtflächenmesser

zum Abstechen der Sichtflächenschweißbraupe bei Kunststoff-Fenstern

- z.B. auf Maschinen von Actual, elumatec, KMW, Pertici, Rotox, Stürtz, TRICKY, Urban, Wegoma, Zierke, etc.
- weitere Sonderausführungen auf Anfrage lieferbar

Groove knives

for grooving top and bottom surfaces of welded UPVC-window corners

- used on machines of Actual, elumatec, KMW, Pertici, Rotox, Stürtz, TRICKY, Urban, Wegoma, Zierke, etc.
- also special design for other machines on request

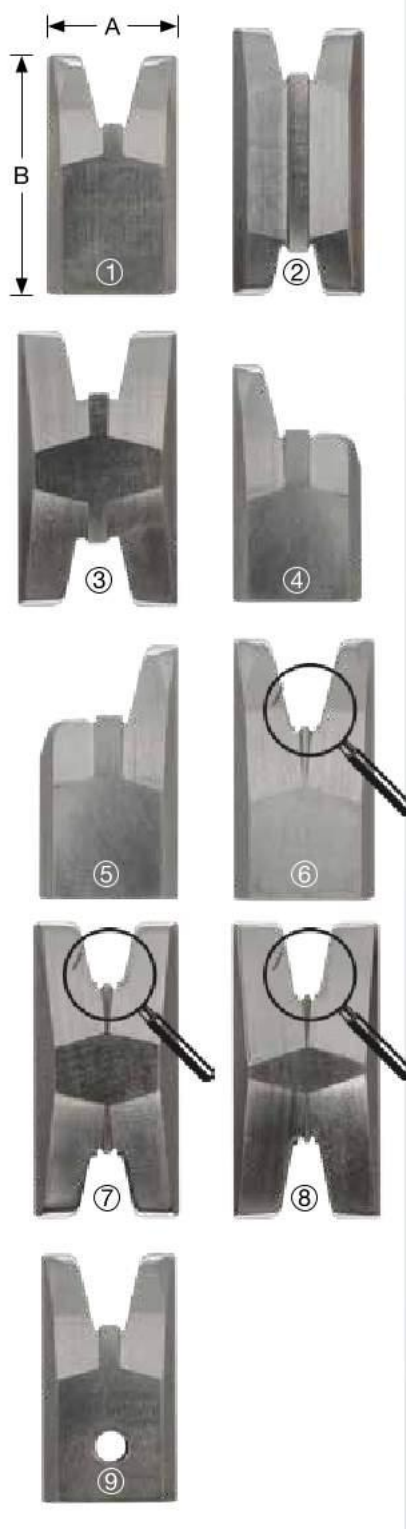

Art.-Nr.	A	B	C	D	Bild / pic.	
900 000 040	19	35	0,0	0,0	1	
900 000 041	19	35	2,5	0,3	1	
900 000 050	19	35	2,5	0,4	1	
900 000 051	19	35	2,5	0,7	1	
900 000 038	19	35	3,0	0,7	1	
900 000 042	19	35	2,5	0,5	1	
900 000 213	19	35	2,8	0,5	1	
900 000 044	19	35	3,0	0,3	1	
900 000 039	19	35	3,0	0,5	1	
900 000 143	19	35	3,5	0,5	1	
900 001 039	19	35	3,5	-0,1	1	
900 000 209	19	40	0,0	0,0	2	
900 000 215	19	40	2,8	0,3	2	
900 000 212	19	40	2,8	0,5	2	
900 000 214	19	40	3,6	0,5	2	
900 000 226	24	30	2,5	0,5	3	
900 000 224	24	41	0,0	-0,25	3	
900 000 220	24	41	2,5	0,5	3	
900 000 219	24	41	3,0	0,7	3	
900 000 229	24	41	3,0	0,3	3	
900 000 221	24	41	3,0	0,5	3	
900 000 072	19	35	3,0	0,5	5	
900 000 071	19	35	3,0	0,5	4	
900 007 042	19	35	V	V	6	
900 007 212	19	40	V	V	7	
900 007 221	24	41	V	V	8	
900 006 040	19	35	0,0	0,0	9	Tricky
900 006 042	19	35	2,5	0,5	9	Tricky
900 006 742	19	35	V	V	9	Tricky

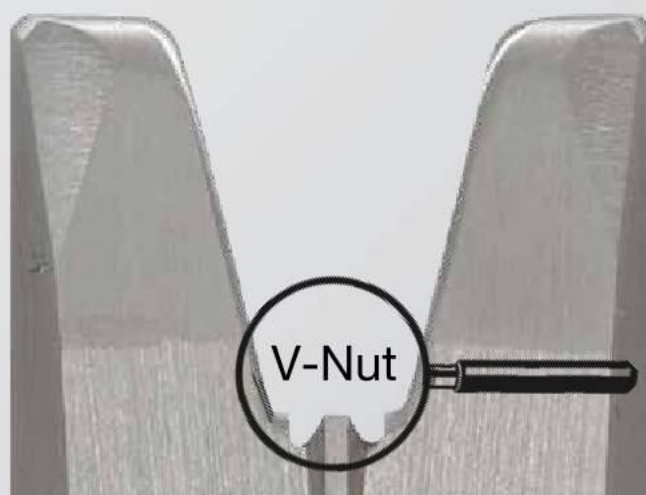

Gehrungsscheren

95020

überall dort unentbehrlich, wo Leisten, Profile, Kunststoff, Gummi oder Holz auf Gehrung geschnitten werden sollen

- zwei stehende Anschläge 45°
- alle Teile hochglanzverchromt mit PVC-Handgriff
- * dünne Klinge für kleine und sehr weiche Profile

Gasket shears

for industry and handicraft to cut ledges, profiles etc. made of plastics, rubber or wood

- two fixed stops 45°
- * thin cutting blade for small or very soft extrusions

Art.-Nr.	Beschreibung/Description	Bild / pic.
900 000 014	Standard / Economy	1
900 000 140	Original / Genuine Löwe	1
900 000 002	Spezial / Special *	2

Ersatzteile / Spare Parts

Art.-Nr.	Beschreibung/Description
900 100 014	Ersatzklinge / Spare blade
900 100 140	Ersatzklinge Original / Spare blade Löwe

Gehrungsschere V-Schnitt

95021

Rationelle Dichtungsmontage ohne Abmessen, ohne Verschnitt

- für alle Dichtungsprofile an Fenstern

V-notch gasket shear

Assembling of sealings without measuring, no waste

- for all kind of window- and door sealings

Art.-Nr.	Beschreibung/Description
900 000 080	Original / Genuine Löwe

Ersatzteile / Spare Parts

Art.-Nr.	Beschreibung/Description
900 000 081	Ersatzklingen (Paar) / Spare knife (pair)

Gehrungsschere – verstellbar –

95022

für alle Dichtungsprofile an Fenstern und Türen

- Winkel 45° / 60° / 75° / 90° / 105° / 120° / 135° einstellbar

Gasket shear – adjustable –

for all kind of window- and door sealing

- adjustable angels 45° / 60° / 75° / 90° / 105° / 120° / 135°

Art.-Nr.
900 000 013

Ersatzteile / Spare Parts

Art.-Nr.	Beschreibung/Description
900 100 014	Ersatzklinge / Spare blade



Seitenschneider für Kunststoff

95024



zum bündigen Abschneiden von Kunststoff
 - 1 = gerade
 - 2 = 45° abgewinkelt für Inneneck-Arbeiten
 - 3 = 85° abgewinkelt für Inneneck-Arbeiten

Side cutters for PVC

for flush cut of PVC

- 1 = straight
 - 2 = 45° angle, internal corner gasket snips
 - 3 = 85° angle, internal corner gasket snips

Art.-Nr. Bild / pic.

900 000 012	1
900 000 015	2
900 000 085	3



Dichtungseinroller

95025

zum problemlosen, raschen Eindrücken der Dichtung

- Rollendurchmesser 40 mm

Gasket rollers

for reasonable assembling of sealings

- Roll diameter 40 mm

Art.-Nr. Bild / pic.

952 000 001	1
952 000 002	2
952 000 003	3
952 000 004	4
952 000 005	5
952 000 006	6
952 000 007	7
952 000 008	8
952 000 009	9
952 000 010	10
952 000 011	11

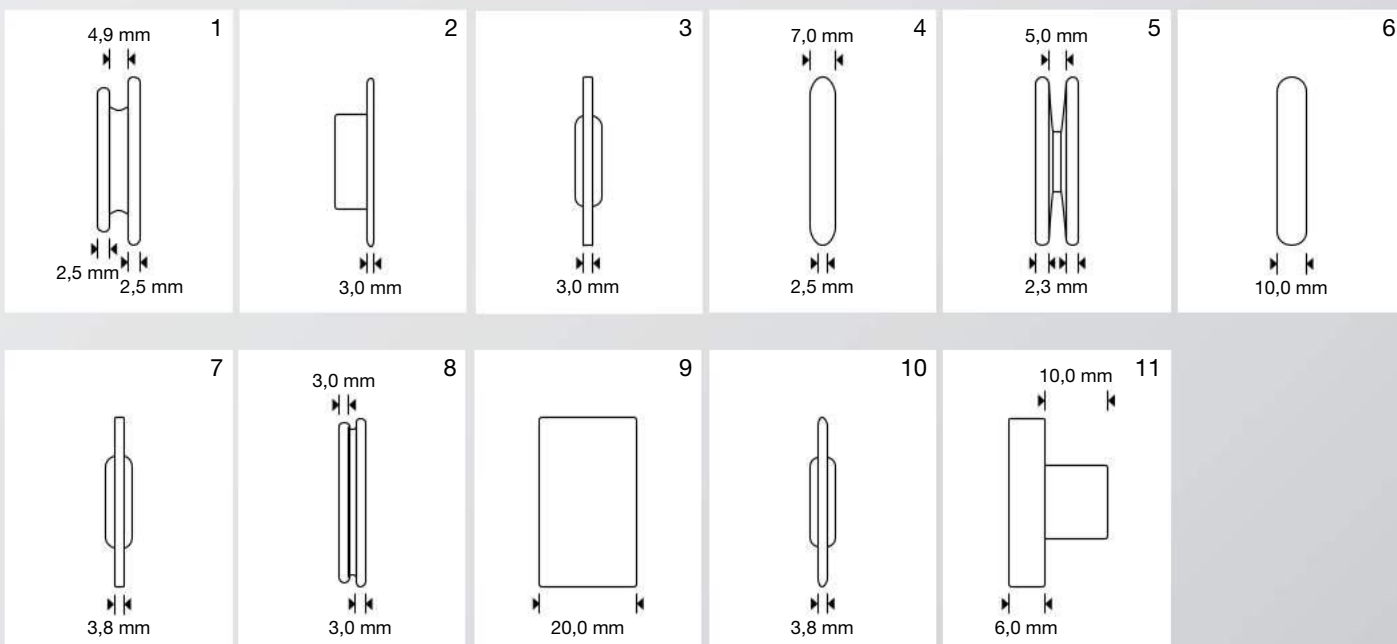

Schrauber Bits

95030

1/4" C 6.3

Insert bits

- 1/4" C 6.3

Art.-Nr.	A	L
900 000 077	PH1	25
900 000 026	PH2	25
900 000 025	PH2	50
900 000 115	PZ2	50
900 000 183	PH2	100
900 000 078	PH3	25
900 000 027	PZ2	25
900 000 086	TORX30	25
900 000 116	TORX10	50
900 000 117	TORX15	50
900 000 118	TORX20	50
900 000 119	TORX25	50
900 000 120	TORX30	50

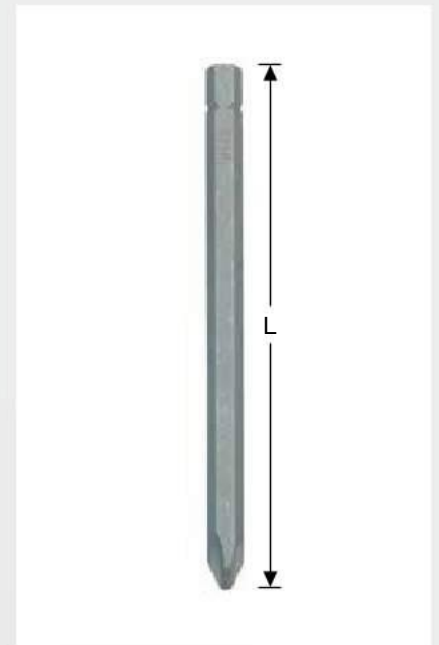

Schrauber Bits

95031

1/4" E 6.3

Insert bits

1/4" E 6.3

Art.-Nr.	A	L	
900 000 177	TORX30	50	
900 000 186	PH2	50	
900 000 187	PH2	100	
900 000 165	PH2	127	red. 6,0 mm
900 000 168	PH2	152	red. 6,0 mm
900 000 169	PH2	200	red. 6,0 mm

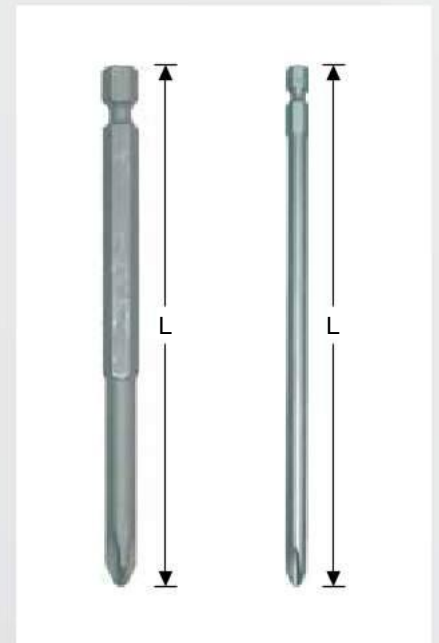

Wussten Sie eigentlich schon,
Did you actually know,



.....dass die Haltbarkeit von Schrauberbits durch Verwendung von ZIRKON-Beschichtungen (ZrN) erheblich verlängert werden kann?

.....that the durability of screwdriver bits can be significantly increased by using ZIRKON-coating (ZrN)?

Schrauber Bits

95032

mit Gewinde

- für stationäre Schraubeinheiten Powasert, Rotox, Striffler, Stürtz, Urban, Wegoma, etc



Insert bits

with thread

- for stationary screw units Powasert, Rotox, Striffler, Stürtz, Urban, Wegoma, etc.

Art.-Nr.	A	B	L	
900 000 184	PH2	M4	33	
900 000 185	PH2	M5	33	
900 000 179	PH2	M5	33	D7 x 25 mm
900 003 185	PH2	M5	33	D7 x 25 mm
900 050 185	PH2	M5	33	ZrN-besch. / ZrN-coated
900 000 079	PH2	M5	45	
900 000 029	PH2	M5	50	
900 000 034	PH2	UNF10-32	45	
900 000 030	PH2	M6	44	
900 000 028	PH2	M6	44	D6 x 23 mm
900 010 034	TX10	UNF10-32	45	
900 015 034	TX15	UNF10-32	45	
900 015 079	TX15	M5	45	
900 025 079	TX25	M5	45	
900 050 028	PH2	M6	44	ZrN-besch. / ZrN-coated
900 020 034	TX20	UNF10-32	45	
900 020 079	TX20	M5	45	
900 050 034	PH2	UNF10-32	45	ZrN-besch. / ZrN-coated
900 050 079	PH2	M5	45	ZrN-besch. / ZrN-coated
900 050 179	PH2	M5	33	ZrN-besch. / ZrN-coated

Schrauber Bits

95033

abgeschrägte Flanken für bestmögliche Passform

- mit Gewinde

- für stationäre Schraubeinheiten Powasert, Rotox, Striffler, Stürtz, Urban, Wegoma, etc.



Insert Bits

with canted edges for perfect fit

- with thread

- For stationary screw units Powasert, Rotox, Striffler, Stürtz, Urban, Wegoma, etc.

Art.-Nr.	A	B	L
900 042 034	PH2	UNF10-32	45
900 042 179	PH2	M5	33

Bit-Verlängerungen mit Gewinde M5

95036

passend für stationäre Schraubeinheiten
- 1/4" E 6.3

Bit extensions for bits with female thread M5

suitable for stationary screw units
- 1/4" E 6.3

Art.-Nr.	L		
900 000 193	90	M5	
900 000 200	116	M5	
900 000 194	128	M5	
900 000 195	150	M5	
900 000 207	115	UNF10/32	elumatec
900 000 205	142	UNF10/32	
900 000 208	155	UNF10/32	elumatec
900 000 211	158	M5	
900 000 206	158	UNF10/32	
900 000 231	162	UNF10/32	
900 000 232	162	M6	
900 000 233	295	M6	



Zwischenstücke

95037

mit beidseitigem Innengewinde

Connections

with female thread on both sides

Art.-Nr.	B	D	L	
900 000 191	M5	8,0	25	
900 001 191	M5	7,6	25	
900 000 192	M5/M6	8,0	30	
900 000 196	UNF10/32	8,0	27	IG/AG I male/female
900 000 190	M6	8,0	25	

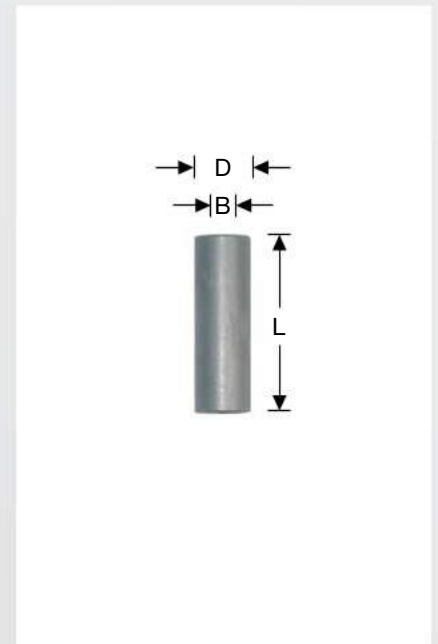

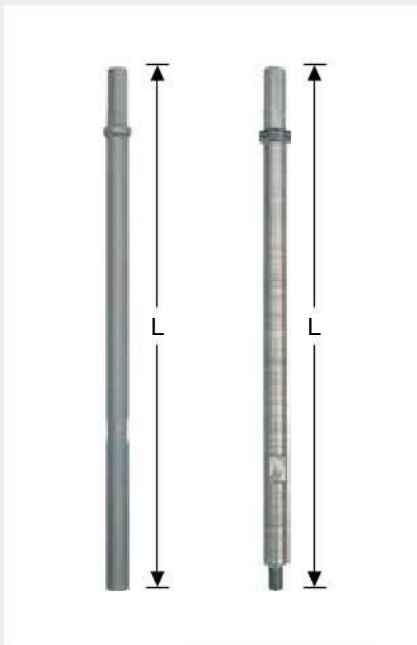

Bit-Verlängerungen

95038

Spezialausführung POWASERT ADS, Stürtz, etc.

Bit extensions

special for POWASERT ADS, Stürtz, etc.

Art.-Nr.	L mm		
900 000 198	175	UNF	Innen-Gewinde / female thread
900 000 201	175	M5	Innen-Gewinde / female thread
900 001 201	158	M5	Aussen-Gewinde / male thread



Bit-Verlängerungen

95039

Spezialausführung
- z. B. Federhenn, Schirmer, etc.

Bit extensions

*special version
- e g. Federhenn, Schirmer, etc.*

Art.-Nr.	L	
900 000 203	154	M5
900 000 204	141	M5



Verglasungshämmer

95100

rückschlagsfrei, für Verglasungsarbeiten

Softhammers

non-rebound, for glazing

Art.-Nr.	A	Bild / pic.
900 000 035	30	1
900 000 060	25	2



Schonhammer THOREX

95102

mit auswechselbaren Einsätzen

Softhammer THOREX

- with removeable pads

Art.-Nr.	D
900 000 069	32 mm / 1,25 inch

Ersatzteile / Spare Parts

Art.-Nr.	Beschreibung / Description
900 001 069	Einsätze / Screw in faces



Verglasungsschaufeln

95103

- 1 = aus Kunststoff
- 2 = aus Holz
- 3 = aus Kunststoff mit Holzgriff

Glazing paddles

- 1 = PVC
- 2 = Wood
- 3 = PVC with wooden handle

Art.-Nr.	Bild / pic.
900 000 059	1
900 000 056	2
900 000 159	3





Stecheisen

95104

Profiqualität

- zum Abstechen von PVC-Schweißraupen

Chisels

professional quality

- to remove spread, splitproof handle

Art.-Nr.	B
900 000 105	4
900 000 112	6
900 000 113	8
900 000 106	10
900 000 109	12
900 000 110	14
900 000 107	16
900 000 114	25
900 000 108	30



Multi-Tool

95105

Universal-Werkzeug für jeden Handwerker

- gehärtete Edelstahlklinge, schlagfest
- auch bestens geeignet zum Ausbrechen der Glasleisten

Multi-Tool

All-purpose tool for every craftsmen

- hardened stainless steel blade, hammer-end
- also for removing bead from PVC and aluminium windows

Art.-Nr.

900 000 210



Saugheber

95106

aus Aluminium, TÜV-geprüft

- für alle Materialien mit glatten und gasdichten Oberflächen wie Glas, Kunststoff, Bleche, beschichtetes Holz, Fliesen, etc.

Suction lifters

made of aluminium, TÜV-proofed

- to lift all materials with smooth surface as glass, sheet metal, tiles, etc.

Art.-Nr.	A	B
900 000 602	2-Kopf / 2-head	70 kg
900 000 604	3-Kopf / 3-head	110 kg

Ersatzteile / Spare Parts

Art.-Nr.	Beschreibung / Description
900 001 601	Ersatzscheibe / suction pad

TEFLON-FOLIE, Rollenware

95107

PREMIUM-Qualität für PVC-Schweißmaschinen

TEFLON foil, rolls

Premium quality for UPVC-welding machines

Art.-Nr.

900 000 129	200 mm	pro Meter / per metre	
900 000 137	220 mm	pro Meter / per metre	
900 000 130	230 mm	pro Meter / per metre	
900 000 131	240 mm	pro Meter / per metre	
900 000 132	250 mm	pro Meter / per metre	
900 000 133	255 mm	pro Meter / per metre	
900 000 134	320 mm	pro Meter / per metre	
900 000 135	340 mm	pro Meter / per metre	
900 000 136	540 mm	pro Meter / per metre	
900 000 127	1000 mm	pro Meter / per metre	
900 000 128	1000 mm	pro Meter / per metre	selbstklebend / self adhesive
900 000 138	1000 mm	pro Meter / per metre	Expert blau 0,15 / expert blue 0,15



Teflon-Folie, Stanzzuschnitte

95108

passend für PVC-Schweißmaschinen

- wie Actual, elumatec, Hollinger, Soenen, Someco, Stürtz, Urban, Wegoma, etc.
- weitere Abmessungen kurzfristig lieferbar!

TEFLON foil, cuttings

suitable for UPVC-welding machines

- as Actual, elumatec, Hollinger, Soenen, Someco, Stürtz, Urban, Wegoma, etc.
- other sizes available upon request!

Art.-Nr.	A	B	
900 510 230	230	510/250	ROTOX
900 440 245	245	440/215	Hollinger
900 250 390	250	390	Urban
900 250 680	250	680	Someco, elumatec Serie 5
900 255 425	255	425	Urban
900 320 460	320	460	Urban AKS
900 340 560	340	560	elumatec 700-730
900 340 680	340	680	Someco, elumatec Serie 5
900 360 350	360	350	Urban AKS
900 535 645	535	645	elumatec 700-730
900 540 680	540	680	Someco, elumatec Serie 5





Universal-Sprühgerät

95400

als Ersatz und zum nachträglichen, kostengünstigen Anbau
an Kopierfräsen, Sägen, Bohreinheiten etc.

- 2 Einlässe: a) für Kühlmittel, b) für Druckluft
- beide regelbar 0,5 - 5 bar

Universal mist spray unit

for replacement or for supplementary and cheap assembling
on copy routers, saws, drilling units, etc.

- 2 inlet ports: a) coolant, b) compressed air
- both adjustable 0,5 - 5 bar

Art.-Nr.

900 227 014 260 mm

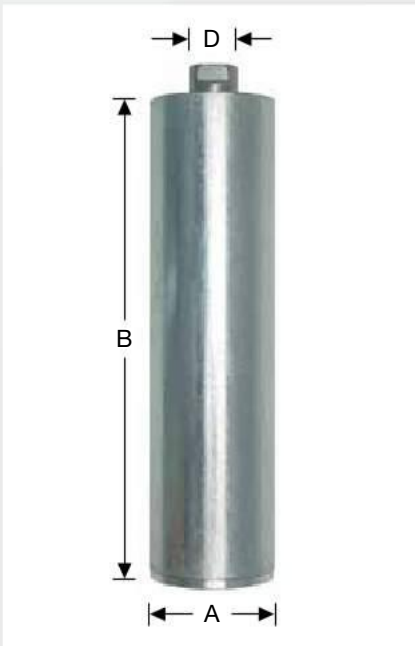

Spannzylinder

95500

einfachwirkend

- Pneumatikanschluß 1/8"
- M8 IG
- C = Hub

Pneumatic clamp cylinders

single action piston stroke

- pneumatic connector 1/8"
- M8 female thread
- C = stroke

Art.-Nr.	A	B	C	D
900 035 405	40	88	5	M8
900 035 040	40	88	40	M8
900 035 080	40	154	80	M8
900 035 120	40	207	120	M8
900 040 080	45	149	80	M8

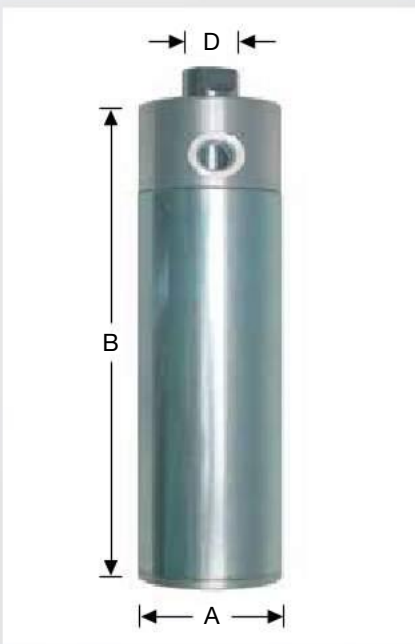

Spannzylinder

95501

doppeltwirkend

- Pneumatikanschluß 1/8"
- C = Hub

Pneumatic clamp cylinders

double-acting piston stroke

- pneumatic connector 1/8"
- C = stroke

Art.-Nr.	A	B	C	D	
900 240 080	40	185	80	M8	Innengewinde / Female thread
900 240 140	40	204	140	M8	Innengewinde / Female thread
900 245 140	45	204	140	M8	Innengewinde / Female thread
900 245 125	45	189	125	M10	Innengewinde / Female thread
900 245 120	45	204	120	M8	Innengewinde / Female thread
901 240 125	40	189	125	M10	Außengewinde / Male thread
901 240 140	40	204	140	M10	Außengewinde / Male thread
901 245 125	45	189	125	M10	Außengewinde / Male thread
901 245 140	45	204	140	M10	Außengewinde / Male thread
902 245 080	45	144	80	M12	Außengewinde / Male thread
902 245 125	45	189	125	M12	Außengewinde / Male thread

Druckluftschläuche (PE)

95503

A = d-Aussen

B = d-Innen

Air-hoses (PE)

A = d-outside

B = d-inside

Art.-Nr.	A	B	
088 207 006	6	4	pro Meter / per metre
088 207 008	8	6	pro Meter / per metre



Druckluftschlauch

95504

hochbelastbar

- mit Metallumflechtung

Air-hose)

heavy duty

- covered with metal texture

Art.-Nr.	A	B	
088 207 018	7	4	pro Meter / per metre



Gummipuffer

95505

passend zu Spannzylindern Gruppe 95500

- 1 = schwarz

- 2 = weiss

Rubber bumpers

suitable to pneumatic clamp cylinder group 95500

- 1 = black

- 2 = white

Art.-Nr.	A	B	C	Bild/pic.
900 000 230	25	10	6	1
900 000 006	25	20	8	1
900 000 005	30	10	8	1
900 000 167	30	10	8	2
900 000 001	40	10	8	1
900 000 004	40	25	8	1
900 001 004	40	25	8	Innengewinde / Female thread
900 000 011	40	25	10	1
900 001 011	40	25	10	Innengewinde / Female thread
104 040 128	40	100	8	3 Innengewinde / Female thread
104 040 112	40	100	12	3 Innengewinde / Female thread
244 060 128	60	100	8	3 Innengewinde / Female thread
244 060 112	60	100	12	3 Innengewinde / Female thread

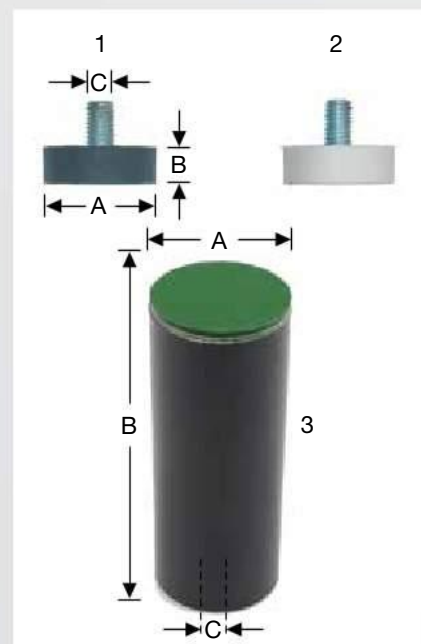



Klemmhebel

95510

mit Gewindebolzen

Handles

with male thread bolt

Art.-Nr.	A	B
078 233 200	6	15
078 233 203	6	25
078 233 207	6	40
078 233 211	6	50
078 233 213	6	60
078 233 201	8	20
078 233 208	8	30
078 233 204	8	40
078 233 206	8	50
078 233 214	8	60
078 233 220	8	70
078 233 221	8	80
078 233 205	10	40
078 233 202	10	50
078 233 215	10	60
078 233 209	10	90
078 233 216	12	30
078 233 217	12	40
078 233 218	12	60
078 233 212	12	70
078 233 219	12	90

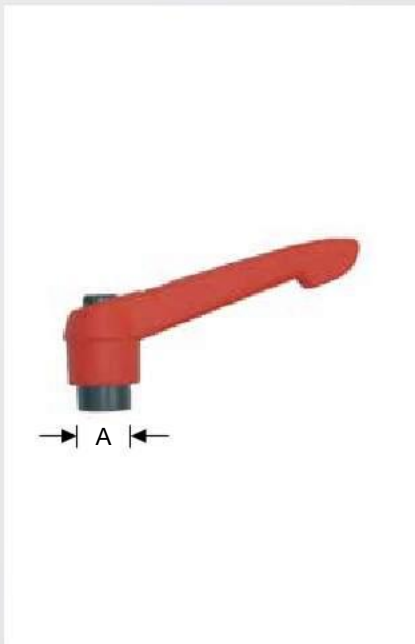

Klemmhebel

95511

mit Innengewinde

Handles

with female thread

Art.-Nr.	A
011 233 201	M6
013 233 200	M8
011 233 200	M10
011 233 202	M12

Zuführschläuche für Schraubeinheiten

95512

mit Gewindebolzen

- PU-Schlauch natur
- für alle gängigen Schraubautomaten, z.B. POWASERT, KS, Taubert, Weber

Screw delivery hoses for screw-unit

with male thread bolt

- PU-material transparent
- for most screw feeders, e.g. POWASERT, KS, Taubert, Weber

Art.-Nr.	A	
088 207 711	7/11 mm	pro Meter / per metre
088 207 813	8/13 mm	pro Meter / per metre
088 207 914	9/14 mm	pro Meter / per metre
088 207 107	10/15 mm	pro Meter / per metre



Magnete

95513

für Schweißzulagen, Profilbeilagen

- starke Ausführung
- mit Mittelloch

Magnets

for welding profile contour blocks, etc....

- heavy duty
- with screw hole

Art.-Nr.	A	B	C
900 000 094	20	8	M5
900 000 091	25	8	M5
900 000 092	32	8	M5
900 000 090	40	8	M5

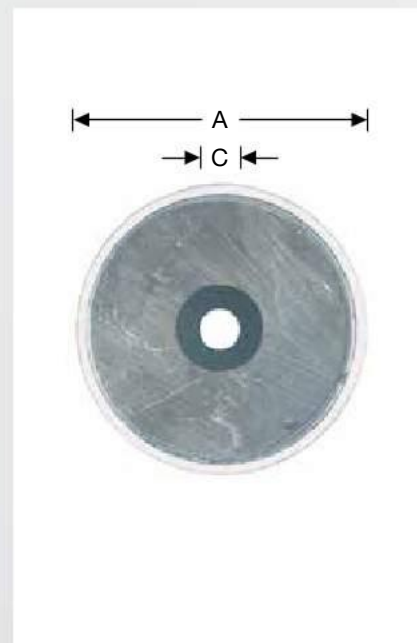



Profilleisten

95516

Länge 2000 mm

- 1 = C-Profilschiene / Stahl
- 2 = Pilzleiste, PE grün
- 3 = Bürstenleiste, PE schwarz
- 4 = Bürstenleiste, 3-reihig
- Spezialverpackung erforderlich - gegen Aufpreis

Glide strips

length 2000 mm

- 1 = steel channel
- 2 = mushroom ledge PE green
- 3 = brush glide strip PE black
- 4 = brush glide strip
- special packaging necessary - extra costs

Art.-Nr.	Bild/pic.
900 000 400	1
900 000 402	2
900 000 403	3
900 000 401	4
Verpackungseinheit 25 Stück / Packaging unit 25 pieces	
900 025 400	1
900 025 402	2
900 025 403	3
900 025 401	4



Gummi-Profile

95517

- Rollenware per Meter
- rutschfest, für Montagetisch, Transportgestelle

Rubber profiles

- rolls, per metre
- slip resistant, for assembling tables, trolleys, profile transportation, glass-handling

Art.-Nr.	Bild/pic.
900 000 405	5 18 x 15 mm

C-Profilschienen / C-steel channel

- C-Profilschienen zu 95517
- C-steel channel fit 95517

Art.-Nr.	Bild/pic.
900 000 400	1



Sonderprofile auf Anfrage / Special extrusions upon demand

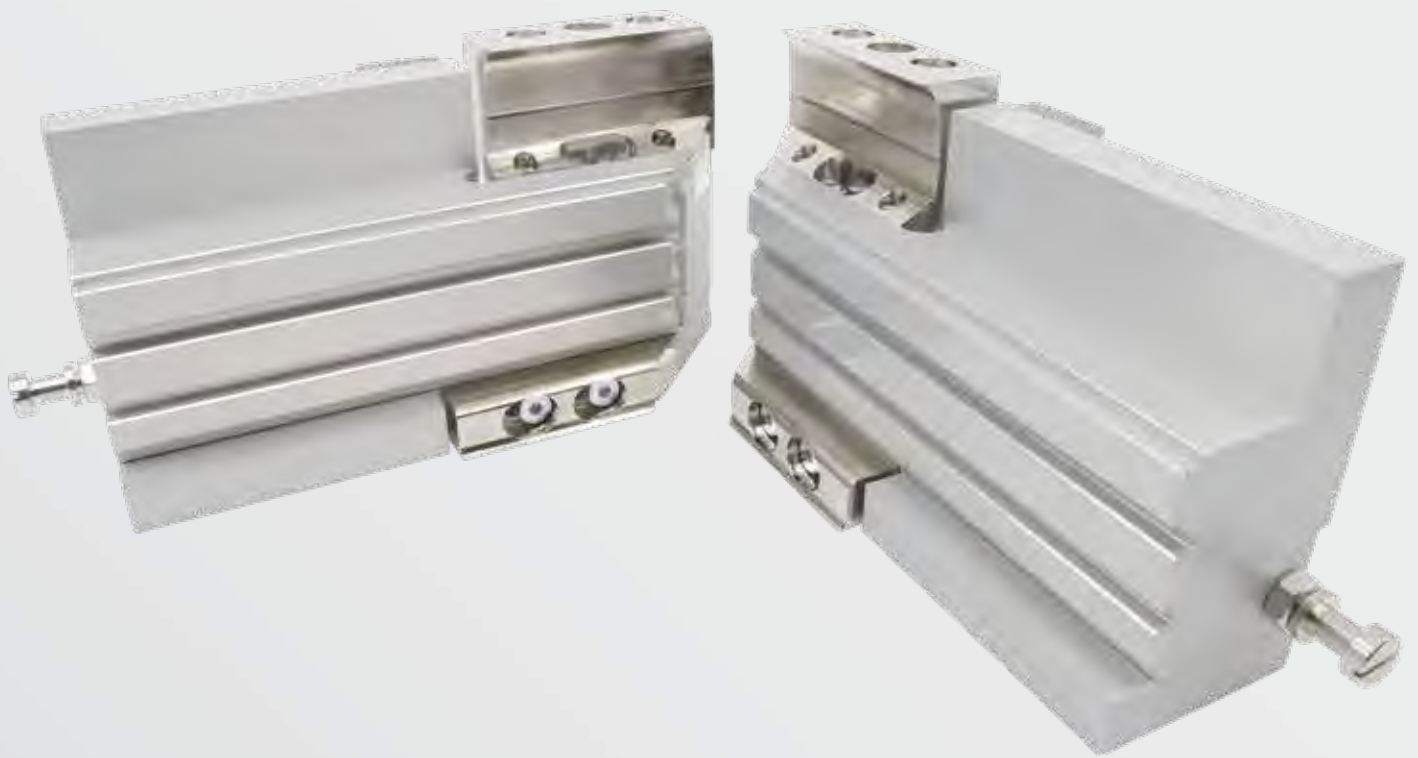

**Sie suchen das Besondere?
*Looking for something special?***



Skalenbänder

- von Rechts nach Links
- für Mess-Systeme, Längenanschlüsse, etc.
- 1 = Polyamid-beschichtet, Farbe gelb
- 2 = lackiert, Farbe weiss

Scale tapes

RH to LH

- for measuring systems, length stops, etc.
- 1 = Polyamid-coated, yellow colour
- 2 = painted, white colour

Art.-Nr.	A	B	C
000 150 020	0 - 2 m	13 mm	1
000 150 030	0 - 3 m	13 mm	1
000 350 030	0 - 3 m	13 mm	2
000 150 050	0 - 5 m	13 mm	1
000 350 050	0 - 5 m	13 mm	2
000 150 100	0 - 10 m	13 mm	1
000 350 100	0 - 10 m	13 mm	2
000 150 150	0 - 15 m	13 mm	1

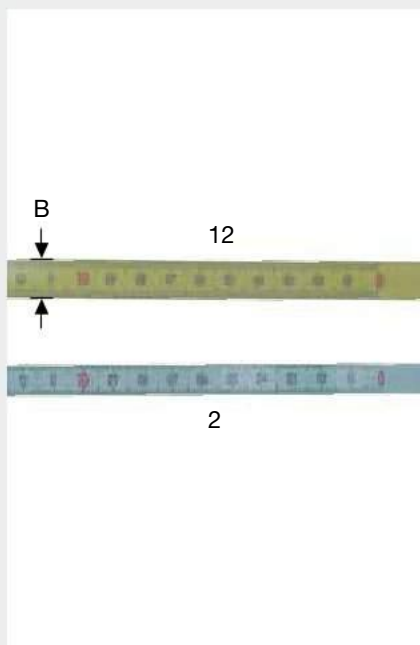

Skalenbänder

- von Links nach Rechts
- für Mess-Systeme, Längenanschlüsse, etc.
- 1 = Polyamid-beschichtet, Farbe gelb
- 2 = lackiert, Farbe weiss

Scale tapes

LH to RH

- for measuring systems, length stops, etc.
- 1 = Polyamid-coated, yellow colour
- 2 = painted, white colour

Art.-Nr.	A	B	C
000 151 020	0 - 2 m	13 mm	1
000 151 030	0 - 3 m	13 mm	1
000 351 030	0 - 3 m	13 mm	2
000 151 050	0 - 5 m	13 mm	1
000 351 050	0 - 5 m	13 mm	2
000 151 100	0 - 10 m	13 mm	1
000 351 100	0 - 10 m	13 mm	2
000 151 150	0 - 15 m	13 mm	1

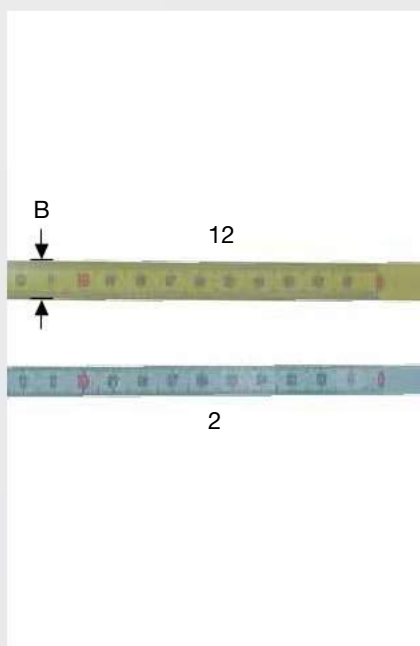

Skalenbänder, selbstklebend

95603

- von Rechts nach Links
- für Mess-Systeme, Längenanschlüsse, etc.
- 1 = Polyamid-beschichtet, Farbe gelb
- 2 = lackiert, Farbe weiss

Scale tapes, self-adhesive

RH to LH

- for measuring systems, length stops, etc.
- 1 = Polyamid-coated, yellow colour
- 2 = painted, white colour

Art.-Nr.	A	B	C
000 250 020	0 - 2 m	13 mm	1
000 450 020	0 - 2 m	10 mm	2
000 450 030	0 - 3 m	10 mm	2
000 250 030	0 - 3 m	13 mm	1
000 450 050	0 - 5 m	10 mm	2
000 250 050	0 - 5 m	13 mm	1
000 450 100	0 - 10 m	10 mm	2
000 250 100	0 - 10 m	13 mm	1

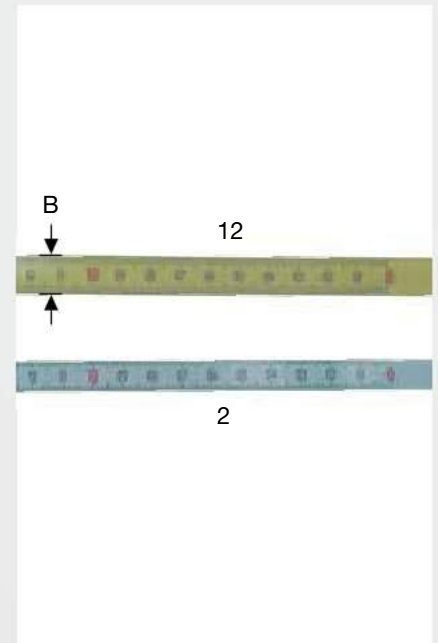

Skalenbänder, selbstklebend

95604

- von Links nach Rechts
- für Mess-Systeme, Längenanschlüsse, etc.
- 1 = Polyamid-beschichtet, Farbe gelb
- 2 = lackiert, Farbe weiss

Scale tapes, self-adhesive

LH to RH

- for measuring systems, length stops, etc.
- 1 = Polyamid-coated, yellow colour
- 2 = painted, white colour

Art.-Nr.	A	B	C
000 451 020	0 - 2 m	10 mm	2
000 251 020	0 - 2 m	13 mm	1
000 451 030	0 - 3 m	10 mm	2
000 251 030	0 - 3 m	13 mm	1
000 451 050	0 - 5 m	10 mm	2
000 251 050	0 - 5 m	13 mm	1
000 451 100	0 - 10 m	10 mm	2
000 251 100	0 - 10 m	13 mm	1

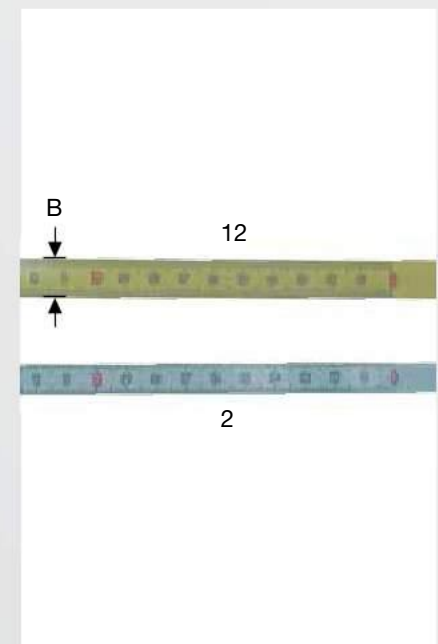

Unsere Sonderwerkzeuge und Beschichtungen immer die perfekte Lösung!

- Individuelle Beratung und Unterstützung für Ihre Sonderlösung oder Optimierung
- Ab kleinen Losgrößen
- Erhöhte Wirtschaftlichkeit
- Kurze Lieferzeit

Our special tools and coatings always the perfect solution!

- *individual advice and support for your special solution or optimization*
- *from small quantities*
- *increased economy*
- *short delivery time*



Lieferbedingungen

- Ab Werk, zzgl. Verpackung
- Mindestbestellwert:
 - Deutschland: € 25,00
 - EU: € 50,00
 - Drittland: auf Anfrage
 - Direktversand pauschal: € 10,00 (nur innerhalb Deutschlands möglich)
- Es wird die preiswerteste Versandart zugrunde gelegt. Mehrkosten für Eilversand, Versicherungen usw. trägt der Auftraggeber, soweit sie von ihm vorgeschrieben sind

Zahlungsbedingungen

- Zahlungsbedingungen nach Vereinbarung

Anmerkungen

- Die gelieferte Ware bleibt bis zur vollständigen Bezahlung aller Forderungen unser Eigentum
- Bei Rücksendungen, die nicht durch uns verschuldet sind, wird an der Gutschrift neben den entstandenen Kosten eine Bearbeitungsgebühr in Abzug gebracht
- Sonderanfertigungen, Reparaturen oder Waren, die nicht mehr den geltenden Standards entsprechen, können grundsätzlich nicht zurückgenommen werden
- Auf Grund des technischen Fortschritts müssen wir uns Abweichungen bei Abbildungen, Zeichnungen und Ausführungen vorbehalten

Hinweis zur Kennzeichnung

Die genannten Marken wie elumatec, EMMEGI, Thorwesten etc. dienen ausschließlich der Beschreibung der Kompatibilität. Es handelt sich nicht um Originalteile, sondern um kompatible Qualitätsprodukte der Marke WEMARO. Alle Markennamen sind Eigentum der jeweiligen Rechteinhaber und werden gemäß §23 MarkenG verwendet

Delivery terms and conditions

- *Ex factory, without packaging*
- *Minimum order value:*
 - Germany: € 25,00
 - EU: € 50,00
 - Others: upon request
- *We choose always the most economical way of delivery. If special carriage (urgent or with special parcel service) is required from the customer, he pays for the extra charge*

Payment conditions

- *Upon request*

Remarks

- *Delivered products stay in our property until complete payment*
- *Returns, through no fault of us, may be returned by prior agreement of the company. They must be undamaged and fully marketable. We reserve the right to make a credit note with restocking and administration charge*
- *Specially manufactured tools, repairs of goods who don't correspond at the actual valid standards, can not be returned*
- *Because of the ongoing technical evolution, data, dimensions and design are given as a guide and does not mean that the goods will conform in absolute detail to the descriptions and illustrations*

Note on brand naming

The brands mentioned as elumatec, EMMEGI, Thorwesten etc. are used solely to describe compability. These are not original parts, but precision parts from WEMARO brand. All brand names are the property of their respective right holders and are used in accordance with §23 MarkenG (german trade mark act)

Impressum

Herausgeber: WEMARO® TOOLS GmbH | Industriestraße 121 | 75417 Mühlacker

Satz und Layout: KÖHLER-FEINAUER ...Die Werbemacher | 73635 Rudersberg | www.koehler-feinauer.de
Änderungen und Irrtümer sind vorbehalten | Ein Nachdruck ohne Genehmigung des Herausgebers ist verboten
Schutzgebühr: € 13,00 | KF 240817 | Ausgabe 01/2026



WEMARO® TOOLS GmbH

Industriestraße 121 · D 75417 Mühlacker

Tel.: +49 (0) 70 41 / 81 33 49 - 0

E-Mail: info@wemaro.de · Website: www.wemaro.de



Präzise . Schnell . Innovativ

WEMARO®