

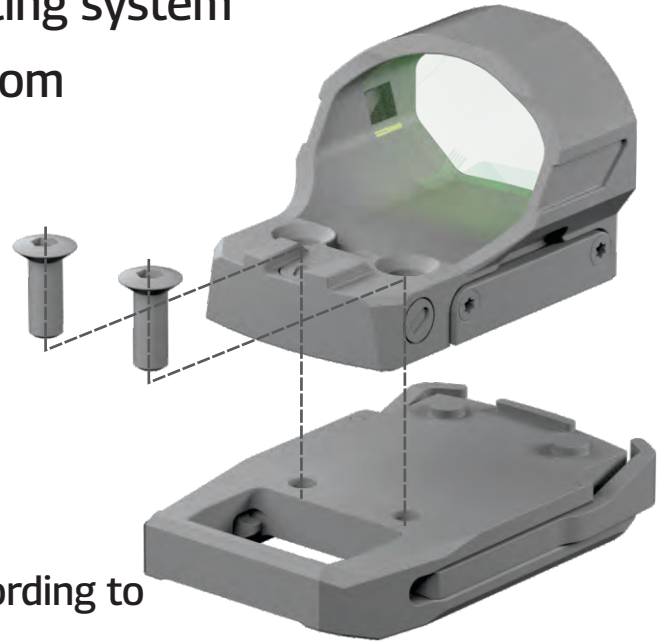

GEN III "Duty" Mount Technical Data Sheet

Quick mechanical-magnetic mounting system with safety locks; manufactured from aerospace-grade aluminum and tempered steel, designed to attach different types of red dot sights to various firearm models.



Specifications:

Rear Sight: Designed for each pistol according to its original height. Composed of two parts: the main body of the sight and a dovetail. Joined together with screws.

Mount: Mechanical-magnetic with a high-power neodymium magnet and lateral safety locks.

Fixing Screws: UNC 6-32 thread.

Assembly Dimensions (RMS):

-Width: 32 mm.

-Length: 51 mm.

-Total Height: 9 mm.

-Sight elevation above slide: 5.3 mm.

Includes: Fixing tools.

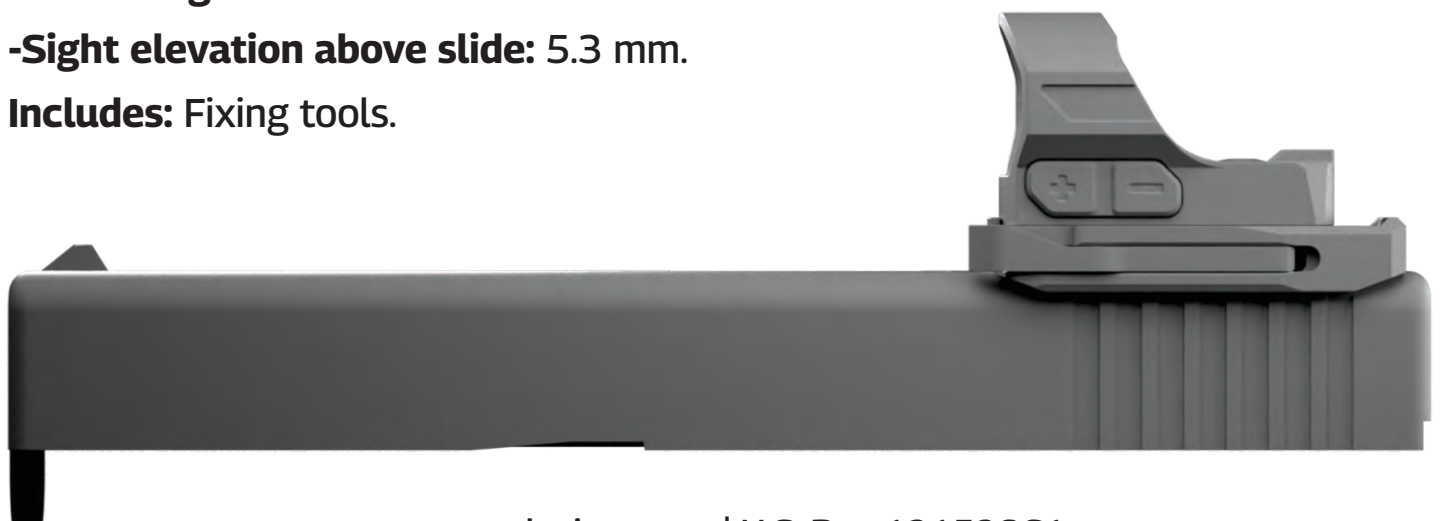



Installation Steps:

1- First, remove the original rear sight and replace it with the one provided in the set (it is recommended to apply thread adhesive to the screws).

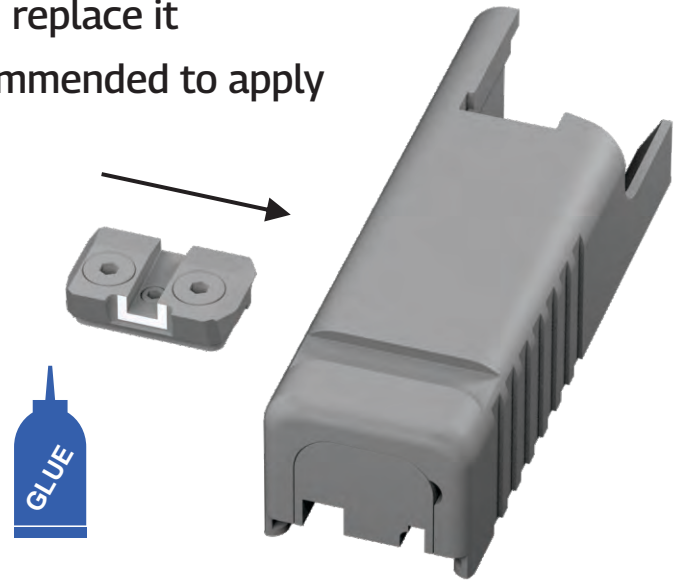
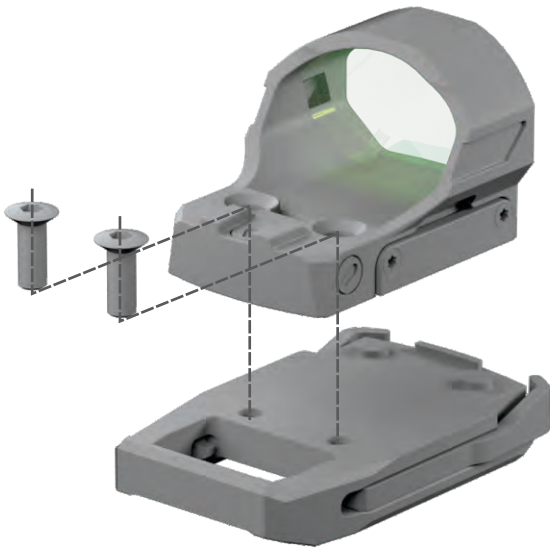

2- In parallel, the sight can be installed on the magnetic mount. Caution must be taken with the magnet as it is very powerful.

3- To attach the assembly, insert the rear sight into the mount and rotate it downward until the lateral locks engage.

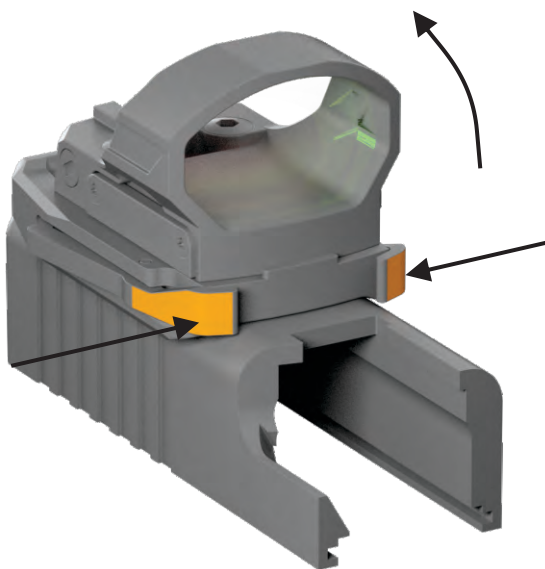

4- To remove the assembly, press the lateral locks to release it and rotate upward, opposite to the installation process.