

# The *multiSTATION*<sup>®</sup> *RIGID miniARM*<sup>®</sup> Technology Guide

 READ THIS PRODUCT INSERT THOROUGHLY BEFORE USE

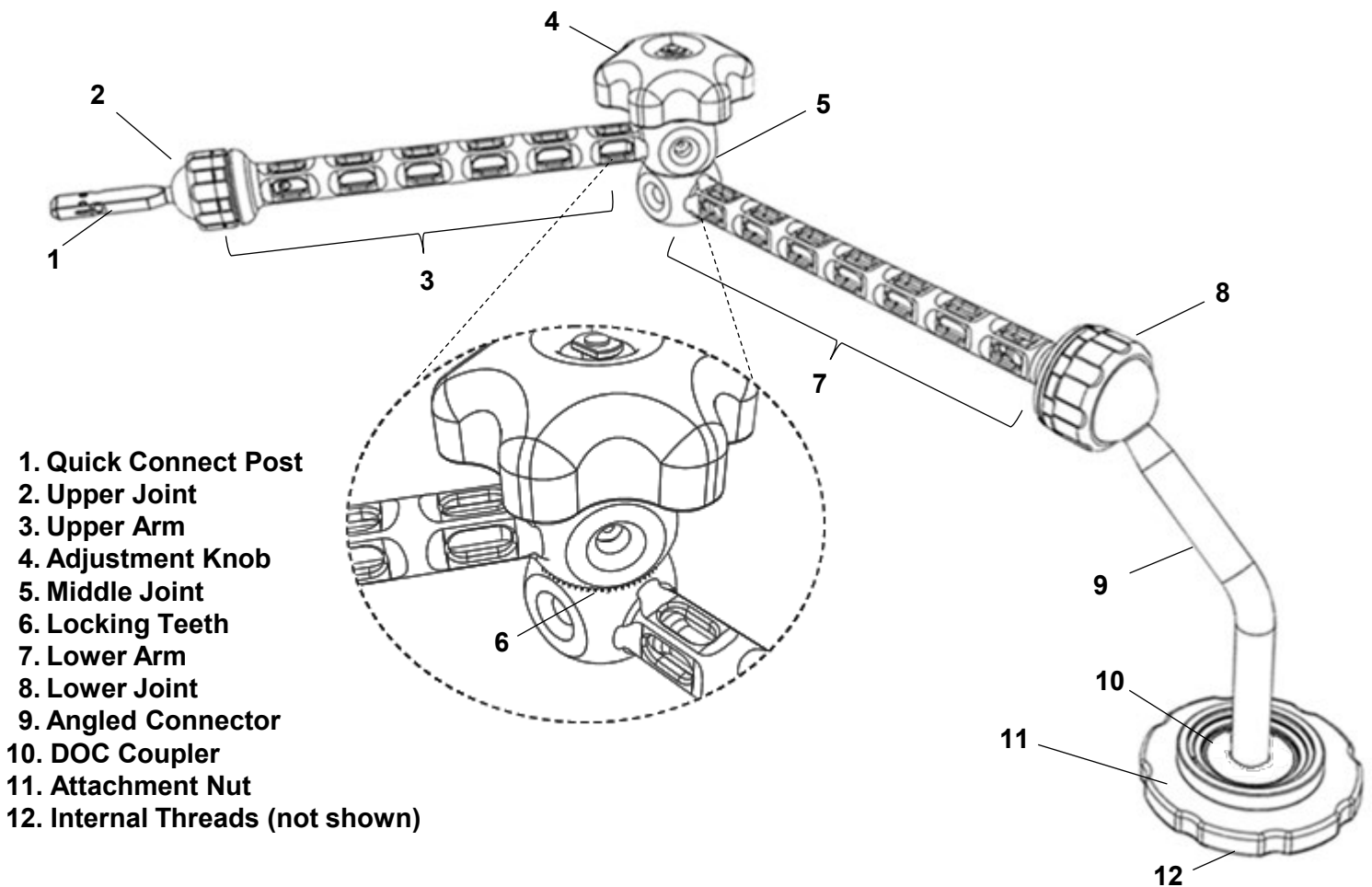

1. Quick Connect Post
2. Upper Joint
3. Upper Arm
4. Adjustment Knob
5. Middle Joint
6. Locking Teeth
7. Lower Arm
8. Lower Joint
9. Angled Connector
10. DOC Coupler
11. Attachment Nut
12. Internal Threads (not shown)

FIG. 1 – *multiSTATION*<sup>®</sup> *RIGID miniARM*<sup>®</sup>



## ***multiSTATION*<sup>®</sup> *RIGID miniARM*<sup>®</sup> DEVICE DESCRIPTION:**

The *RIGID miniARM*<sup>®</sup> (FIG. 1) is an accessory in the *multiSTATION*<sup>®</sup> System. It is a reusable, sterilizable, repositionable support member providing an exceptionally stable base, when used with a separately available *multiSTATION*<sup>®</sup> RAIL CLAMP, on which interchangeable adapters are connected. Adapters and devices can be attached at the quick connect post 1 as needed for surgery. The upper joint 2 allows the quick connect post to be positioned accurately relative to the upper arm 3. Clockwise rotation of the adjustment knob 4 secures the *miniARM*<sup>®</sup> in the selected orientation. Counterclockwise rotation of the adjustment knob releases the *miniARM*<sup>®</sup> for repositioning. The middle joint 5 allows for both the articulation and secure positioning, through the locking teeth 6, of the upper arm relative to the lower arm 7. The lower joint 8 allows for the articulation and secure positioning, through the locking dimples (not shown) of the lower arm relative to the angled connector 9. The angled connector terminates in a DOC coupler 10 that engages the receiving socket of the *multiSTATION*<sup>®</sup> RAIL CLAMP.

The attachment nut 11 locks the DOC coupler into the receiving socket when the attachment nut and its internal threads 12 (not shown) are rotated clockwise, threading into the receiving socket. As it is tightened into the socket, the DOC coupler and the angled connector are secured so that they can no longer move.

## **INDICATIONS FOR USE:**

The *multiSTATION*<sup>®</sup> *RIGID miniARM*<sup>®</sup> is indicated for use by surgeons to hold instruments in a fixed position for a period of time.

# INSTRUCTIONS FOR USE

## LOCKING, RELEASING, and PLACING the *multiSTATION*<sup>®</sup> RIGID *miniARM*<sup>®</sup>

Prior to each use, test the *RIGID miniARM*<sup>®</sup> by confirming that acceptable holding strength is achieved. Discontinue use if holding strength is inadequate. These instructions for attaching a *RIGID miniARM*<sup>®</sup> to a receiving DOC apply to use with the receiving DOC of any separately available *multiSTATION*<sup>®</sup> RAIL CLAMP already attached to a draped table rail.

### 1 LOCK

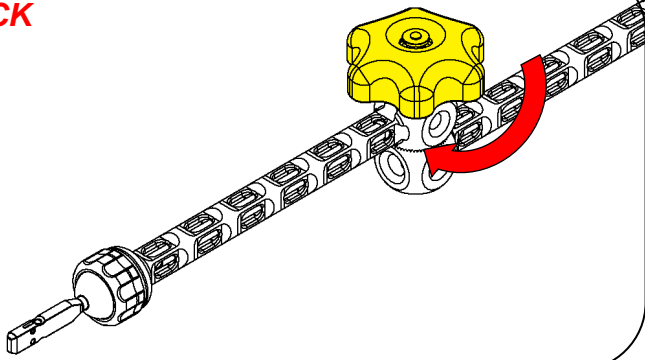

1. **LOCK** the *RIGID miniARM*<sup>®</sup> by rotating the adjustment knob clockwise until fully seated.

**NOTE:** If any undesirable movement of *miniARM*<sup>®</sup> or attachment is observed, further tighten adjustment knob clockwise.

### 2 RELEASE

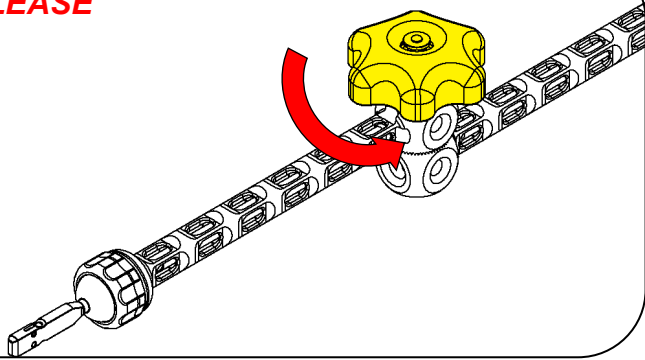

2. **RELEASE** the *miniARM*<sup>®</sup> by rotating the adjustment knob counterclockwise.

**NOTE:** When rotating the adjustment knob, make sure to support the *miniARM*<sup>®</sup>.

### 3 PLACE

Receiving DOC of a *multiSTATION*<sup>®</sup> RAIL CLAMP

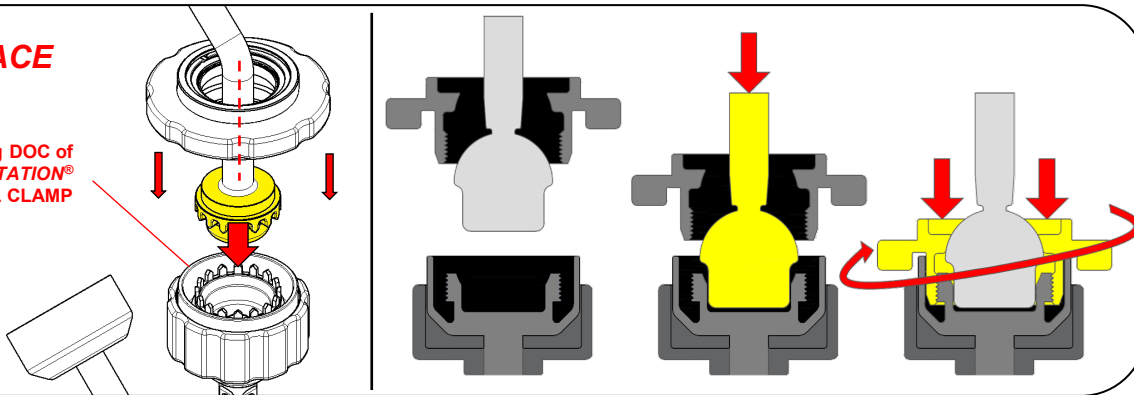

3. **PLACE** the attachment nut and the DOC coupler onto the receiving DOC of the *multiSTATION*<sup>®</sup> RAIL CLAMP to attach the *miniARM*<sup>®</sup> to the DOC.

### 4 ROTATE

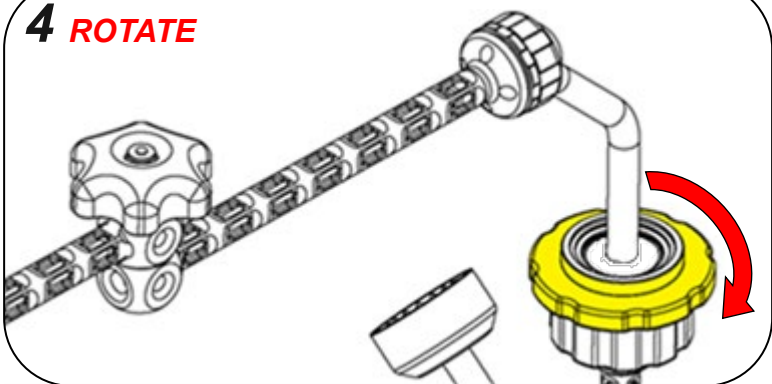

4. **ROTATE** the attachment nut onto the DOC clockwise, threading it onto *RAIL CLAMP* DOC.

**NOTE:** If threading is difficult, turn the attachment nut counterclockwise to unscrew, then carefully realign the attachment nut with the DOC and repeat the clockwise rotation. Do not force the attachment nut to rotate, as doing so can cause the *miniARM*<sup>®</sup> and *RAIL CLAMP* to bind.

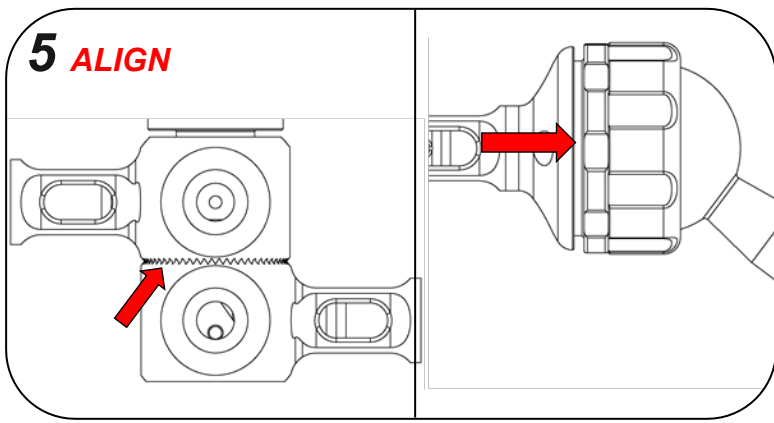

5. **ALIGN** the locking teeth of the middle joint and ensure the lower arm is fully seated in a locking dimple of the lower joint.

**NOTE:** Full engagement of the lower arm into a locking dimple of the lower joint can be felt as the *miniARM*<sup>®</sup> is positioned.

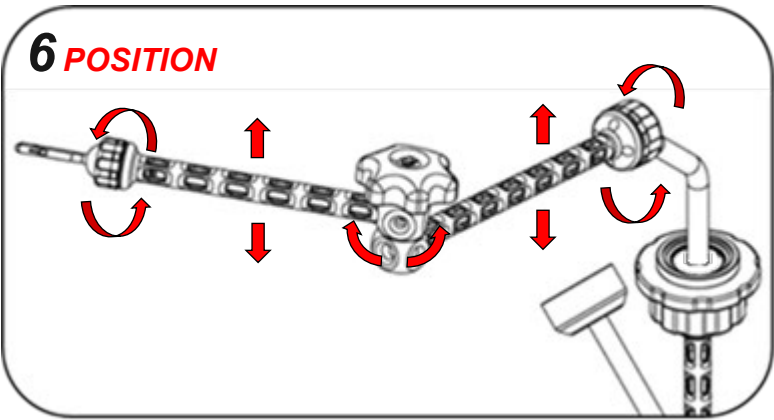

6. **POSITION** the *miniARM*<sup>®</sup> while in its unlocked state by pushing, pulling, or rotating the quick connect post, upper arm, lower arm about the three joints for adjustability in all directions.

When the *miniARM*<sup>®</sup> has been positioned as desired with the locking teeth aligned and the locking dimple seated, lock the system by rotating the adjustment knob clockwise until sufficient holding force has been achieved.

### ATTACHING AN ADAPTER TO THE *multiSTATION*<sup>®</sup> RIGID *miniARM*<sup>®</sup>

Steps 1 and 2 show one example of how *multiSTATION*<sup>®</sup> adapters (separately available) are attached and adjusted to the RIGID *miniARM*<sup>®</sup>. The adapter may be attached to the RIGID *miniARM*<sup>®</sup> either before or after attaching the *miniARM*<sup>®</sup> to a *multiSTATION*<sup>®</sup> RAIL CLAMP.

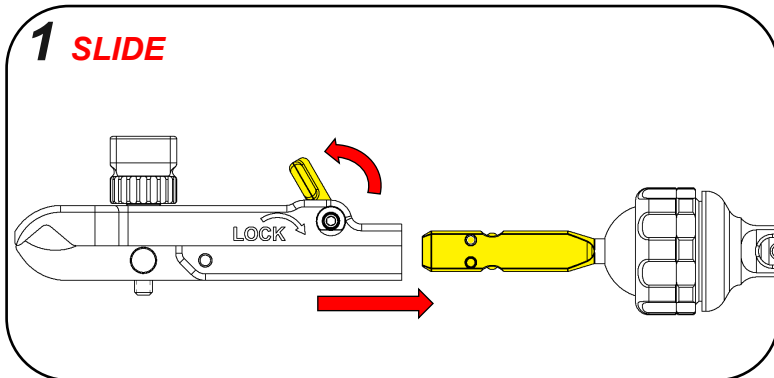

1. **SLIDE** the desired adapter onto the quick connect post while the adapter locking lever is rotated to the unlocked position.

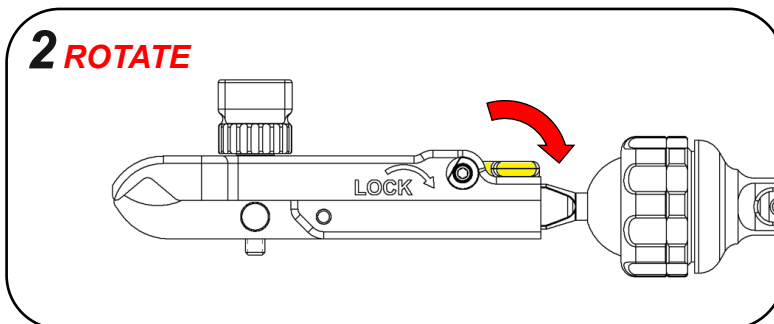

2. **ROTATE** the adapter locking lever to the locked position to secure the adapter onto the *miniARM*<sup>®</sup>.

## REMOVAL and CLEANUP

Removal of the *RIGID miniARM*® may be eased by keeping the *miniARM*® in its locked position.

### 1 ROTATE

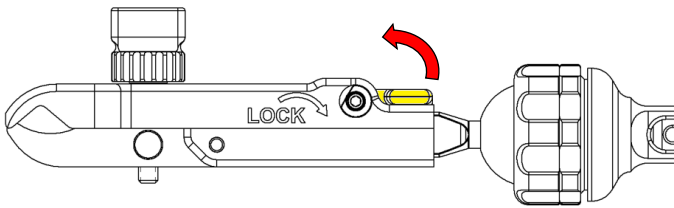

1. **ROTATE** the locking lever of the attached adapter to the unlocked position.

### 2 DETACH

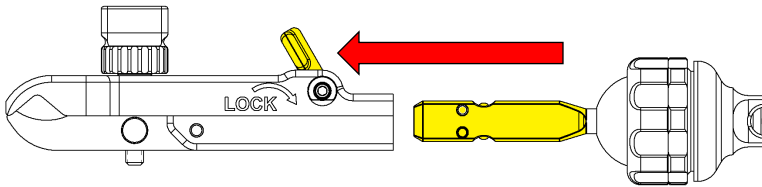

2. **DETACH** the adapter by sliding it off the quick connect post.

### 3 ROTATE

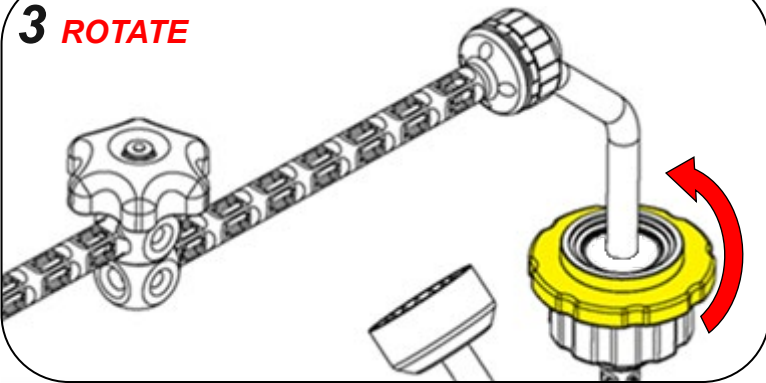

3. **ROTATE** the attachment nut off the *multiSTATION*® RAIL CLAMP DOC. Turn the attachment nut counterclockwise to unscrew from the DOC.

### 4 REMOVE

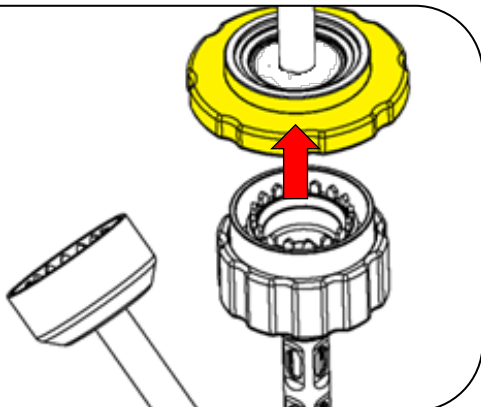

4. **REMOVE** the *RIGID miniARM*® from the *multiSTATION*® RAIL CLAMP DOC.

# multiSTATION® RIGID miniARM® REPROCESSING

- Disassemble and clean the device immediately after use. Do not allow a soiled device to dry.
- The device is not validated to be cleaned or sterilized with an adapter and/or a rail clamp attached.
- Cleaning agent used in validation: Steris Prolystica® 2X (enzymatic, neutral pH).
- Perform the final rinse using only freshly prepared purified water/highly purified water.
- Never use metal brushes or steel wool for cleaning.
- Prepare and reprocess any adapters or rail clamps according to each device's instructions for use.
- This device is unaffected by pressure changes associated with reprocessing.
- The sterilization tray is NOT designed for cleaning devices. It must be processed separately. The tray is only intended for sterilization, transport, and storage of reusable instruments. For more tray information, see the sterilization tray instructions for use.

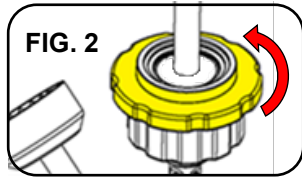
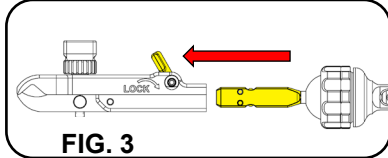
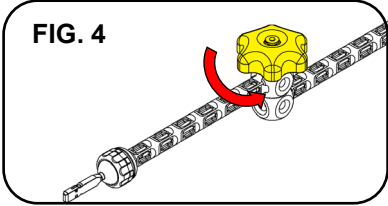
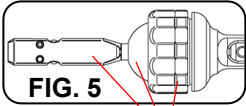
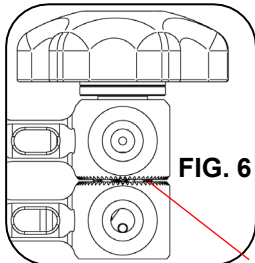
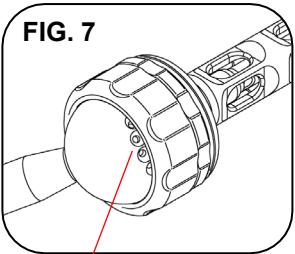
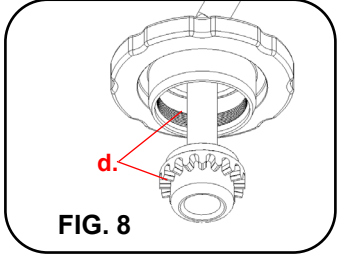
<p><b>POINT OF USE</b></p>	<ol style="list-style-type: none"> <li>1. Disassemble and clean device immediately after use.</li> <li>2. Do not allow soiled devices to dry.</li> </ol>
<p><b>PREPARATION</b></p>	<ol style="list-style-type: none"> <li>1. Remove the <i>RIGID miniARM®</i> from the rail clamp by turning the attachment nut counterclockwise (FIG. 2).</li> </ol>  <ol style="list-style-type: none"> <li>2. Remove any adapters from the <i>RIGID miniARM®</i> by rotating the adapter locking lever and sliding the adapter off the quick connect post (FIG. 3).</li> </ol> <p><b>NOTE:</b> FIG. 3 shows the clamping adapter being removed; other adapters are removed in the same manner.</p>  <ol style="list-style-type: none"> <li>3. Rotate the adjustment knob counterclockwise until fully open such that the knob cannot be rotated anymore and every joint moves freely (FIG. 4).</li> </ol>  <ol style="list-style-type: none"> <li>4. If using the <i>multiSTATION® Sterilization Tray</i> (Part Number 100034), clean the tray separately according to the sterilization tray instructions for use.</li> </ol>
<p><b>MANUAL PRE-CLEANING</b></p>	<ol style="list-style-type: none"> <li>1. Soak in enzymatic, neutral pH cleaning solution for a minimum of 5 minutes. Refer to detergent manufacturer's instructions for temperature and concentration.</li> <li>2. Use a plastic-bristled brush to thoroughly scrub the device's exterior surfaces, paying special attention to the following:             <ol style="list-style-type: none"> <li>a. Retaining ring, upper ball joint, and quick connect post (FIG. 5)</li> <li>b. Locking teeth of the middle joint (FIG. 6)</li> <li>c. Lower ball joint, locking dimples (FIG. 7)</li> <li>d. DOC coupler, attachment nut, and internal threads (FIG.8)</li> </ol> </li> </ol>     <ol style="list-style-type: none"> <li>3. Rinse with warm water (38–45°C [100–113°F]) for a minimum of 2 minutes.</li> <li>4. Proceed with one of the two required cleaning options: ultrasonic or automated.</li> </ol>

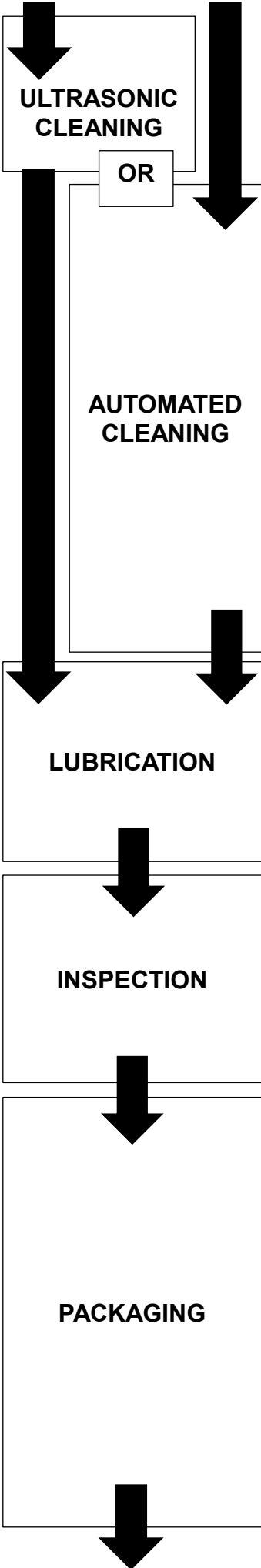

1. Clean in ultrasonic bath with enzymatic, neutral pH cleaning solution for a minimum of 15 minutes. Refer to detergent manufacturer's instructions for temperature and concentration.
2. Rinse with warm water (38–45°C [100–113°F]) for a minimum of 4 minutes. To ensure a complete rinse, use a clean plastic-bristled brush to scrub the device.

1. A washer-disinfector with fundamentally approved efficiency (e.g., according to EN ISO 15883) is required and it must be properly installed, qualified, and regularly subjected to maintenance and testing.
2. Load the device into the washer-disinfector. Avoid contact between devices and arrange to allow for proper drainage.
3. Operate the washer-disinfector cycle with an additional rinse cycle.
4. The following minimum parameters were validated as effective for cleaning this device in an automated washer:

Treatment	Time (mm:ss)	Temperature °C (°F)	Additive
Pre-wash (Cold tap)	2:00	17 (63)	N/A
Wash (Hot tap)	2:00	40 (104)	Steris Prolystica® 2X
Rinse	2:00	70 (158)	N/A
Rinse	2:00	70 (158)	Optional lubricant
Dry	15:00	80 (176)	N/A

1. Apply instrument lubricant mixed to manufacturer's recommendations to prolong instrument life by submerging the entire device in the lubricant for a minimum of 30 seconds. If the hospital washer-disinfector has a lubrication cycle this can be used instead of manual lubrication.
- NOTE:** LSI has validated the use of MicroLube™ C Instrument Lubricant on this device. Other instrument lubricant brands have not been tested and performance and results cannot be guaranteed.

1. Carefully inspect the device to assure that all visible soil has been removed. Generally, unmagnified visual inspection under good light conditions is sufficient. Particular attention should be paid to the locations in FIGS. 5-8. Repeat cleaning process if soil is detected.
2. Visually inspect the device for mild or excessive corrosion. If corrosion is present, discontinue use of the device in surgery, but complete reprocessing.
3. Visually inspect the device for any damage. If parts are damaged, discontinue use of the device in surgery, but complete reprocessing.

1. Ensure the *RIGID miniARM*® adjustment knob is rotated counterclockwise completely and every joint moves freely.
2. If using a sterilization pouch, place each instrument in its own individual pouch. If using a sterilization tray, read the sterilization tray instructions for use before proceeding. Ensure that the sterilization tray has been cleaned according to the sterilization tray instructions for use and load the tray bottom according to FIG. 9.
3. Package the device according to TABLE 1. The barrier system for sterilized re-usable instruments should meet the following requirements:
  - ISO 11607-1
  - Suitable for pre-vacuum steam sterilization
  - Appropriate for medical use
  - Grade appropriate for weight of loaded tray per sterilization tray instructions for use and facility procedures

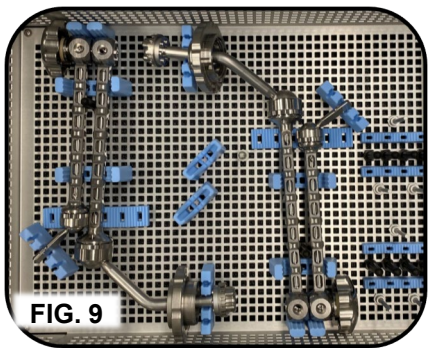

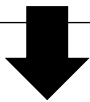

## STERILIZATION

1. The device must be properly cleaned prior to sterilization.
2. Perform sterilization cycle according to TABLE 1:

<b>TABLE 1: <i>multiSTATION</i>® <i>RIGID miniARM</i>® Sterile Packaging and Processing</b>			
<b>Method</b>	Moist heat (steam) sterilization according to ANSI/AAMI ST79	Moist heat (steam) sterilization according to ANSI/AAMI ST79	Immediate use steam sterilization according to ANSI/AAMI ST79
<b>Container</b>	<i>multiSTATION</i> ® <i>Sterilization Tray</i> P/N 100034	No tray	No tray
<b>Cycle</b>	Pre-vacuum (Pre-vac)	Pre-vacuum (Pre-vac)	Pre-vacuum (Pre-vac)
<b>Packaging</b>	2-layer polypropylene wrap	Pouch	No packaging
<b>Temperature</b>	132-137°C (270–279°F)	132-137°C (270–279°F)	132-137°C (270–279°F)
<b>Exposure Time</b>	4– 18 minutes	4– 18 minutes	4– 18 minutes
<b>Dry Time</b>	65 minutes (minimum)	25 minutes (minimum)	N/A

Device(s) processed by immediate use sterilization should be transferred immediately, using aseptic technique, from the sterilizer to the point of use.

Refer to ANSI/AAMI ST79, Comprehensive Guide to Steam Sterilization and Sterility Assurance in Health Care Facilities.

The *RIGID miniARM*® has been validated to 100 reprocessing cycles. The useful lifespan of a surgical instrument is largely dependent on the care and handling of the instrument. Careful inspection and functional testing of the instrument should be used to determine the end of its serviceable life.

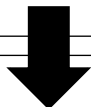

## STORAGE

1. During storage, ensure the device remains in a sterile condition ready for reuse.
2. Shelf life is dependent on the sterile barrier employed, storage manner, and environmental and handling conditions.

### CONTRAINDICATIONS

- Do not use with attachments other than accessories provided by LSI SOLUTIONS®.
- These devices are not intended for use except as indicated.

### WARNINGS

- Federal law restricts this device to sale, distribution and use by, or on, the order of a physician.
- Read and become familiar with all instructions, warnings, and cautions before using this product.
- The *RIGID miniARM*® shall be used in accordance with these Instructions for Use.
- Improper use of the *RIGID miniARM*® may cause serious injury. In addition, improper care and maintenance of the device may render the device non-sterile prior to patient use and may cause serious injury to the health care provider or the patient.
- When using the *RIGID miniARM*®, patients must be immobilized or anesthetized.
- Discontinue use of the *RIGID miniARM*® when moving the patient or when the patient is moving.
- Surgical or endoscopic procedures should be performed only by physicians having adequate training and familiarity with relevant techniques and anatomy. Medical literature relating to techniques, complications, and hazards should be consulted prior to use.

**PRECAUTIONS**

- The **RIGID miniARM®** is packaged as non-sterile. Clean and sterilize prior to use.
- If there are any variations between these instructions for use and either your facility's policies and/or your cleaning/sterilizing equipment manufacturer's instructions, those variations should be brought to the attention of the appropriate responsible hospital personnel for resolution before proceeding with cleaning and sterilizing your device.
- Use of the **RIGID miniARM®** for a task other than what it is intended for can result in a damaged or broken device.
- Prior to use, inspect the **RIGID miniARM®** to ensure proper function and condition. Do not use devices if they do not satisfactorily perform their intended function or if they have physical damage.
- Surgical instruments vary between manufacturers. Before instruments and accessories from different manufacturers are employed together in a procedure, verify compatibility and ensure electrical isolation or grounding are not compromised.
- Avoid mechanical shock or overstressing the **RIGID miniARM®**.
- Only the cleaning and sterilization processes which are defined within these instructions for use have been validated.
- Check stability of surgical table accessory rails or rail adapters before table mounting the **RIGID miniARM®**. Only mount to secure surgical tables and well-affixed horizontal table rails; avoid attaching rail clamps to structures that are loose or not secure.
- When loosening the adjustment knob, make sure to support the **miniARM®**. An unlocked and unsupported **miniARM®** can fall and may cause harm, damage to the device, damage to the affixed **multiSTATION®** adapter, or injury to the patient or user.
- Store at room temperature.

**ADVERSE REACTIONS**

- No documented adverse reactions.
- Any serious incident that has occurred in relation to the device should be reported to the manufacturer and the country competent authority.

**ORDERING INFORMATION**

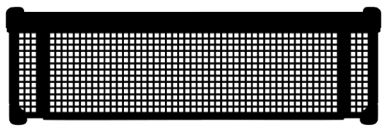
<b>TABLE 2: multiSTATION® RIGID miniARM® PRODUCT ORDERING</b>			
	REORDER	PRODUCT	DESCRIPTION
	REF 080950	<b>multiSTATION® RIGID miniARM®</b>	1 Shelf Box
	REF 100034	<b>multiSTATION® Sterilization Tray*</b>	1 Shelf Box



LSI SOLUTIONS, Inc.  
 7796 Victor-Mendon Road  
 Victor, New York 14564 U.S.A.  
 Phone: +1 585.869.6600  
 Customer Service: +1 866.575.3493  
 Technical Support: +1 866.428.9092  
 Fax: +1 585.742.8086  
 www.lsisolutions.com

\*The **multiSTATION® Sterilization Tray** is manufactured by Summit Medical, 815 Vikings Parkway, Suite 100, St. Paul, MN 55121 U.S.A.

**MADE IN THE USA**

This Product Comes with our **LSI SOLUTIONS® Perfect Performance Policy®**  
 Call us at 866.575.3493 any time.

Patents: [www.lsisolutions.com/patents](http://www.lsisolutions.com/patents)

The LSI logo, LSI Solutions, Multistation, Miniarm, and Perfect Performance Policy are registered trademarks and trademarks of LSI SOLUTIONS®.  
 Copyright © 2021, LSI SOLUTIONS®. All Rights Reserved.



Symbol Glossary:  
[www.lsisolutions.com/symbols](http://www.lsisolutions.com/symbols)



The Basic UDI-DI for this device is 0850200006multistationDF.

Prolystica is a registered trademark of Steris. Microlube is a registered trademark of PurposeBuilt Brands. Use of these names, trademarks and brands does not imply endorsement. All company, product and service names used in this technology guide are for identification purposes only.

P/N 081247J 18-MAY-2026