

The *multiSTATION*[®] CLAMPING ADAPTER

Technology Guide

 READ THIS PRODUCT INSERT THOROUGHLY BEFORE USE

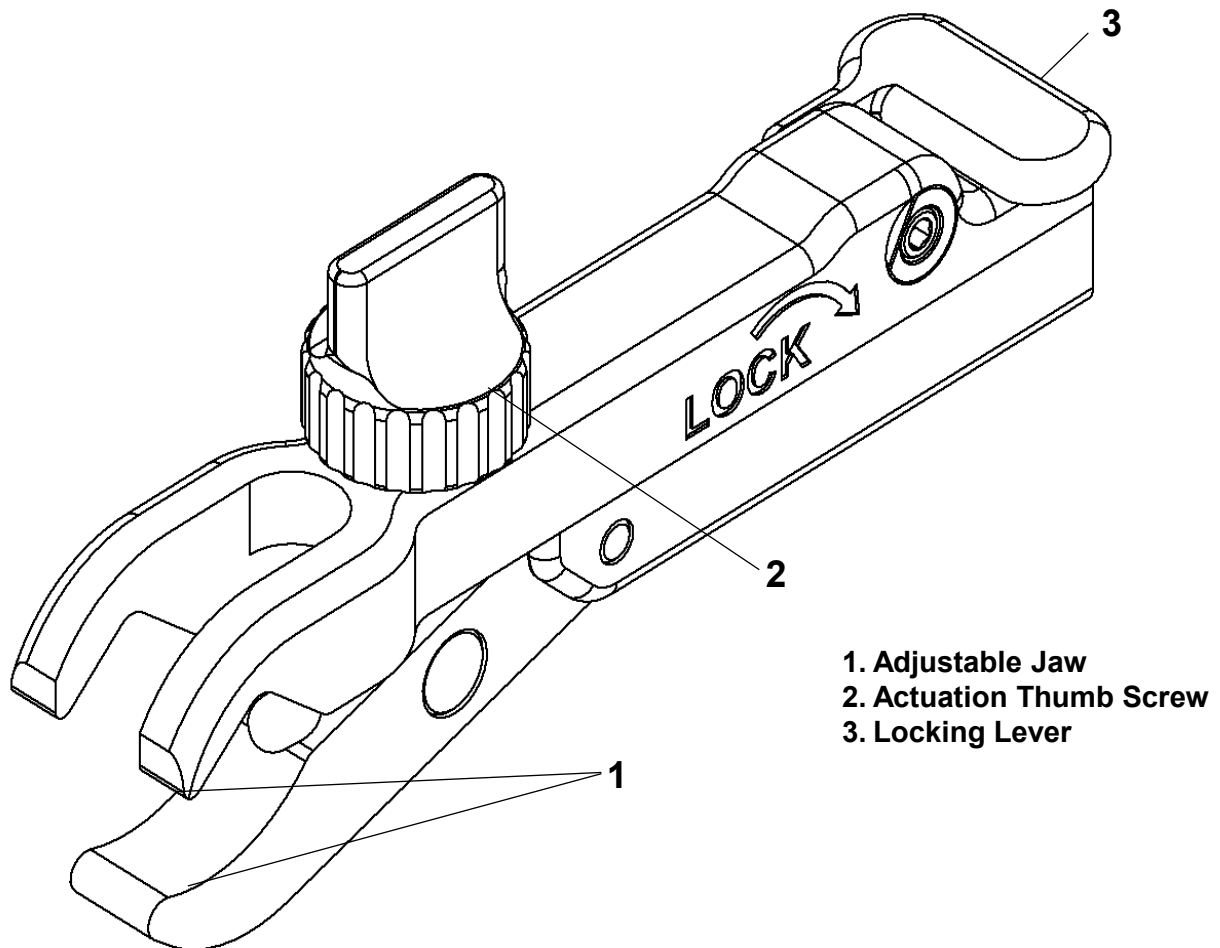

FIG. 1 –*multiSTATION*[®] CLAMPING ADAPTER

LSSOLUTIONS[®]

***multiSTATION*[®] CLAMPING ADAPTER DEVICE DESCRIPTION:**

The *multiSTATION*[®] CLAMPING ADAPTER (FIG. 1) is used with the *RIGID miniARM*[®] or the *CLICK RELEASE*[™] *miniARM*[®]. The adjustable jaw **1** is opened or closed by rotating the actuation thumb screw **2** counterclockwise or clockwise, respectively. Opening and closing the adjustable jaw allows the user to secure or release a desired surgical device. Rotating the locking lever **3** to the unlocked position allows the adapter to slide over the quick connect post of the holder. The adapter is locked into place by rotating the locking lever to the locked position. The adapter is designed to hold surgical instruments with a shaft diameter of 4-14 mm.

INDICATIONS FOR USE:

The *multiSTATION*[®] CLAMPING ADAPTER is indicated for use by surgeons to hold instruments in a fixed position for a period of time.

INSTRUCTIONS FOR USE

The *multiSTATION*[®] CLAMPING ADAPTER may be attached to the *miniARM*[®] either before or after attaching the holder to a *multiSTATION*[®] RAIL CLAMP.

1 SLIDE

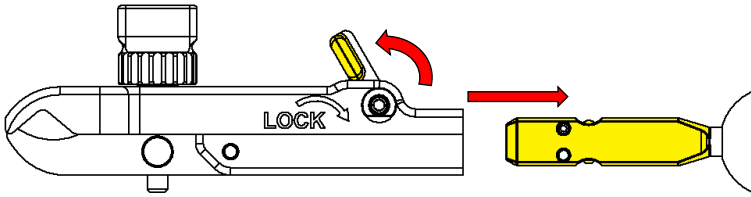

1. **SLIDE** the adapter onto the quick connect post of the holder while the locking lever is rotated to the unlocked position.

2 ROTATE

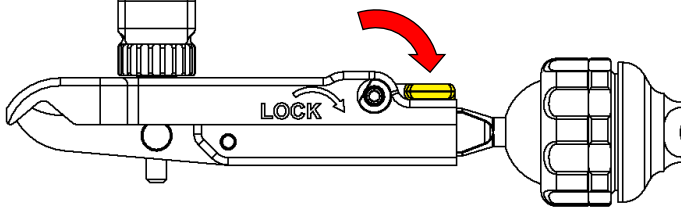

2. **ROTATE** the locking lever to the locked position to secure the adapter onto the holder.

3 OPEN

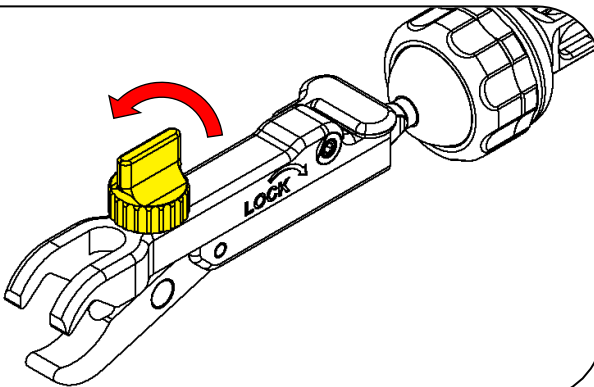

3. **OPEN** the adjustable jaw by rotating the actuation thumb screw counterclockwise.

4 SECURE

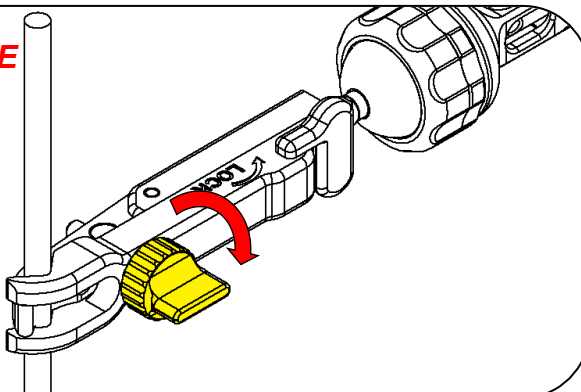

4. **SECURE** a surgical device in the adapter by rotating the actuation thumb screw clockwise, thus closing the adjustable jaw.

NOTE: Do not use excessive force when securing a surgical device in the adjustable jaw.

REMOVAL and CLEANUP

This process may be made easier by having the *miniARM*® locked while handling.

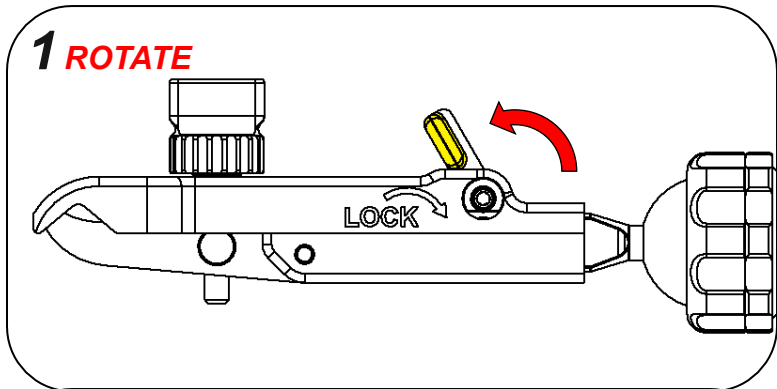

1. **ROTATE** the locking lever to the unlocked position.

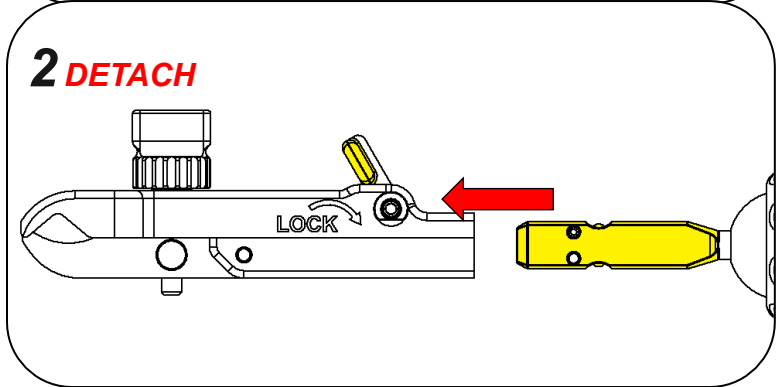

2. **DETACH** the adapter by sliding it off the holder's quick connect post.

multiSTATION® CLAMPING ADAPTER REPROCESSING

- Disassemble and clean the device immediately after use. Do not allow a soiled device to dry.
- The device is not validated to be cleaned or sterilized with a holder and/or rail clamp attached.
- Cleaning agent used in validation: Steris Prolystica® 2X (enzymatic, neutral pH).
- Perform the final rinse using only freshly prepared purified water/highly purified water.
- Never use metal brushes or steel wool for cleaning.
- Prepare and reprocess any holders or rail clamps according to each device's instructions for use.
- This device is unaffected by pressure changes associated with reprocessing.
- The sterilization tray is NOT designed for cleaning devices. It must be processed separately. The tray is only intended for sterilization, transport, and storage of reusable instruments. For more tray information, see the sterilization tray instructions for use.

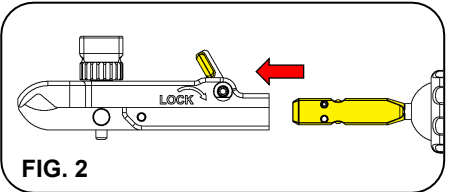
POINT OF USE	<ol style="list-style-type: none"> 1. Disassemble and clean device immediately after use. 2. Do not allow soiled devices to dry.
PREPARATION	<ol style="list-style-type: none"> 1. Remove the adapter from the holder by rotating the locking lever to the unlocked position and sliding the adapter off the quick connect post (FIG 2). 2. If using the <i>multiSTATION</i>® Sterilization Tray (Part Number 100034), clean the tray separately according to the sterilization tray instructions for use. <div style="text-align: right;">  <p>FIG. 2</p> </div>

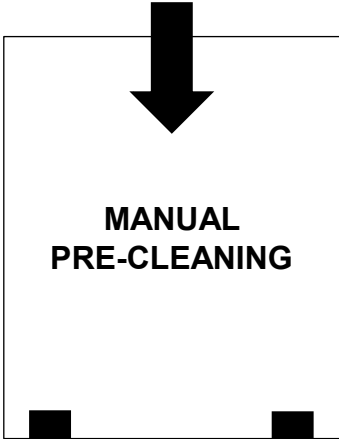

1. Soak in enzymatic, neutral pH cleaning solution for a minimum of 5 minutes. Refer to detergent manufacturer's instructions for temperature and concentration.
2. Use a plastic-bristled brush to thoroughly scrub the device's exterior surfaces, paying special attention to the following (FIG 3):
 - a. Attachment opening
 - b. Screw head
 - c. Threading and jaw cavity
3. Rinse with warm water (38–45°C [100–113°F]) for a minimum of 2 minutes.
4. Proceed with one of the two required cleaning options: ultrasonic or automated.

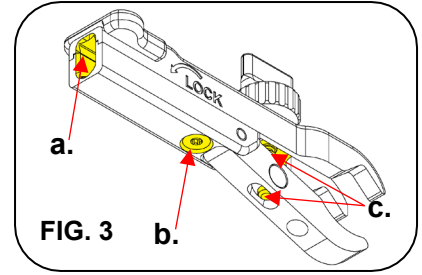

1. Clean in ultrasonic bath with enzymatic, neutral pH cleaning solution for a minimum of 15 minutes. Refer to detergent manufacturer's instructions for temperature and concentration.
2. Rinse with warm water (38–45°C [100–113°F]) for a minimum of 4 minutes. To ensure a complete rinse, use a clean plastic-bristled brush to scrub the device.

OR

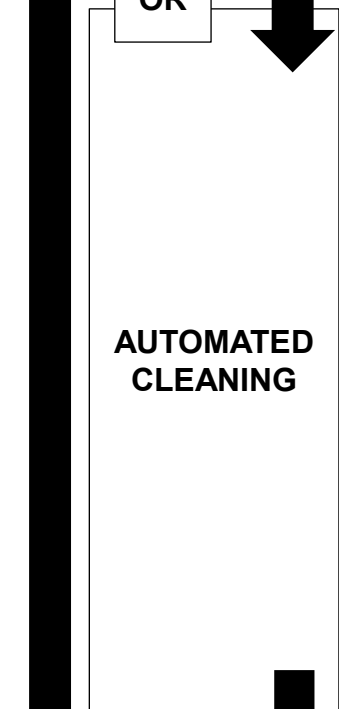

1. A washer-disinfector with fundamentally approved efficiency (e.g., according to EN ISO 15883) is required and it must be properly installed, qualified, and regularly subjected to maintenance and testing.
2. Load the device into the washer-disinfector. Avoid contact between devices and arrange to allow for proper drainage.
3. Operate the washer-disinfector cycle with an additional rinse cycle.
4. The following minimum parameters were validated as effective for cleaning this device in an automated washer:

Treatment	Time (mm:ss)	Temperature °C (°F)	Additive
Pre-wash (Cold tap)	2:00	17 (63)	N/A
Wash (Hot tap)	2:00	40 (104)	Steris Prolystica® 2X
Rinse	2:00	70 (158)	N/A
Rinse	2:00	70 (158)	Optional lubricant
Dry	15:00	80 (176)	N/A

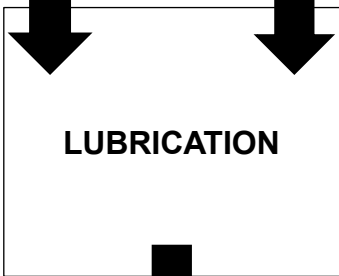

1. Apply instrument lubricant mixed to manufacturer's recommendations to prolong instrument life by submerging the entire device in the lubricant for a minimum of 30 seconds. If the hospital washer-disinfector has a lubrication cycle this can be used instead of manual lubrication.
- NOTE:** LSI has validated the use of MicroLube™ C Instrument Lubricant on this device. Other instrument lubricant brands have not been tested and performance and results cannot be guaranteed.

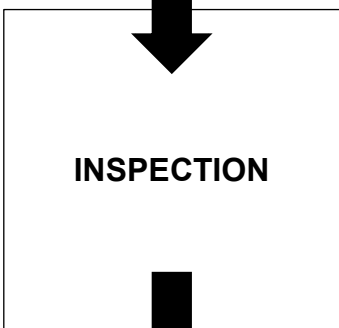

1. Carefully inspect the device to assure that all visible soil has been removed. Generally, unmagnified visual inspection under good light conditions is sufficient. Particular attention should be paid to the locations in FIG. 3. Repeat cleaning process if soil is detected.
2. Visually inspect the device for mild or excessive corrosion. If corrosion is present, discontinue use of the device in surgery, but complete reprocessing.
3. Visually inspect the device for any damage. If parts are damaged, discontinue use of the device in surgery, but complete reprocessing.

PACKAGING

1. If using a sterilization pouch, place each instrument in its own individual pouch. If using a sterilization tray, read the sterilization tray instructions for use before proceeding. Ensure that the sterilization tray has been cleaned according to the sterilization tray instructions for use and load the tray bottom according to FIG. 4.

2. Package the device according to TABLE 1. The barrier system for sterilized reusable instruments should meet the following requirements:

- ISO 11607-1
- Suitable for pre-vacuum steam sterilization
- Appropriate for medical use
- Grade appropriate for weight of loaded tray per sterilization tray instructions for use and facility procedures

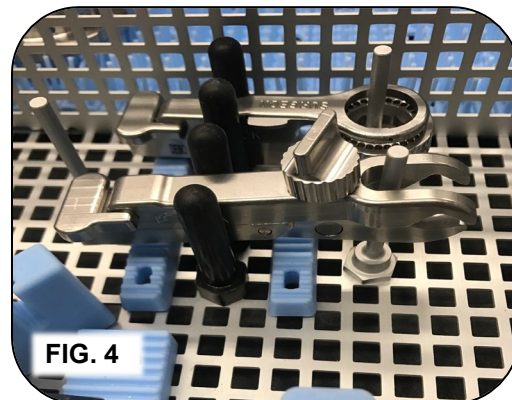

FIG. 4

STERILIZATION

1. The device must be properly cleaned prior to sterilization.
2. Perform sterilization cycle according to TABLE 1:

TABLE 1: <i>multiSTATION</i>® CLAMPING ADAPTER Sterile Packaging and Processing			
Method	Moist heat (steam) sterilization according to ANSI/AAMI ST79	Moist heat (steam) sterilization according to ANSI/AAMI ST79	Immediate use steam sterilization according to ANSI/AAMI ST79
Container	<i>multiSTATION</i> ® Sterilization Tray P/N 100034	No tray	No tray
Cycle	Pre-vacuum (Pre-vac)	Pre-vacuum (Pre-vac)	Pre-vacuum (Pre-vac)
Packaging	2-layer polypropylene wrap	Pouch	No packaging
Temperature	132-137°C (270-279°F)	132-137°C (270-279°F)	132-137°C (270-279°F)
Exposure Time	4-18 minutes	4-18 minutes	4-18 minutes
Dry Time	65 minutes (minimum)	25 minutes (minimum)	N/A

Device(s) processed by immediate use sterilization should be transferred immediately, using aseptic technique, from the sterilizer to the point of use.

Refer to ANSI/AAMI ST79, Comprehensive Guide to Steam Sterilization and Sterility Assurance in Health Care Facilities.

The *multiSTATION*® CLAMPING ADAPTER has been validated to 20 reprocessing cycles. The useful lifespan of a surgical instrument is largely dependent on the care and handling of the instrument. Careful inspection and functional testing of the instrument should be used to determine the end of its serviceable life.

STORAGE

1. During storage, ensure the device remains in a sterile condition ready for reuse.
2. Shelf life is dependent on the sterile barrier employed, storage manner, and environmental and handling conditions.

CONTRAINDICATIONS

- These devices are not intended for use except as indicated.

WARNINGS

- Federal law restricts this device to sale, distribution, and use by, or on, the order of a physician.
- Read and become familiar with all instructions, warnings, and cautions before using this product.
- The *multiSTATION*[®] *CLAMPING ADAPTER* shall be used in accordance with these instructions for use.
- Improper use of the *multiSTATION*[®] *CLAMPING ADAPTER* may cause serious injury. In addition, improper care and maintenance of the device may render the device non-sterile prior to patient use and may cause serious injury to the health care provider or the patient.
- When using the *multiSTATION*[®] *CLAMPING ADAPTER*, patients must be immobilized or anesthetized.
- Discontinue use of the *multiSTATION*[®] *CLAMPING ADAPTER* when the patient is moving or being moved.
- Surgical or endoscopic procedures should be performed only by physicians having adequate training and familiarity with relevant techniques and anatomy. Medical literature relating to techniques, complications, and hazards should be consulted prior to use.

PRECAUTIONS

- **The *multiSTATION*[®] *CLAMPING ADAPTER* is packaged as non-sterile.** Clean and sterilize prior to use.
- If there are any variations between these instructions for use and the policies of your facility and/or the instructions of your cleaning/sterilizing equipment manufacturer, those variations should be brought to the attention of the appropriate responsible hospital personnel for resolution before proceeding with cleaning and sterilizing your device.
- Use of the *multiSTATION*[®] *CLAMPING ADAPTER* for a task other than what it is intended for can result in a damaged or broken device.
- Prior to use, inspect the *multiSTATION*[®] *CLAMPING ADAPTER* to ensure proper function and condition. Do not use devices if they do not satisfactorily perform their intended function or if they have physical damage.
- Surgical instruments vary between manufacturers. Before instruments and accessories from different manufacturers are employed together in a procedure, verify compatibility and ensure electrical isolation or grounding are not compromised.
- Avoid mechanical shock or overstressing the *multiSTATION*[®] *CLAMPING ADAPTER*.
- Only the cleaning and sterilization processes that are defined within these instructions for use have been validated.
- Be sure to adjust the *multiSTATION*[®] *CLAMPING ADAPTER* actuation thumb screw enough to hold the device securely without overtightening. Overtightening the *multiSTATION*[®] *CLAMPING ADAPTER* can result in damage to the held device while insufficient tightening could result in device slippage.
- Store at room temperature.

ADVERSE REACTIONS

- No documented adverse reactions.
- Any serious incident that has occurred in relation to the device should be reported to the manufacturer and the country competent authority.

TABLE 2: *multiSTATION*[®] *CLAMPING ADAPTER* PRODUCT ORDERING

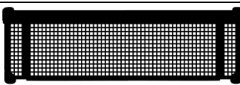
	REORDER	PRODUCT	DESCRIPTION
	REF 080519	<i>multiSTATION</i> [®] <i>CLAMPING ADAPTER</i>	1 Shelf Box
	REF 100034	<i>multiSTATION</i> [®] <i>Sterilization Tray</i> *	1 Shelf Box



LSI SOLUTIONS, Inc.
7796 Victor-Mendon Road
Victor, New York 14564 U.S.A.
Phone: +1 585.869.6600
Customer Service: +1 866.575.3493
Technical Support: +1 866.428.9092
Fax: +1 585.742.8086
www.lsisolutions.com

*The *multiSTATION*[®] *Sterilization Tray* is manufactured by Summit Medical, 815 Vikings Parkway, Suite 100, St. Paul, MN 55121 U.S.A.

MADE IN THE USA

This Product Comes with our LSI SOLUTIONS[®] *Perfect Performance Policy*[®]. Call us at 866.575.3493 any time.

Patents: www.lsisolutions.com/patents

The LSI logo, LSI Solutions, Perfect Performance Policy, Click Release, Miniarm, and Multistation are registered trademarks and trademarks of LSI SOLUTIONS[®].

Copyright © 2021, LSI SOLUTIONS[®]. All Rights Reserved.



Symbol Glossary:
www.lsisolutions.com/symbols

CE Emergo Europe
Westervoortsedijk 60
6827 AT Arnhem
The Netherlands

The Basic UDI-DI for this device is 0850200006multistationDF.

Polystyica is a registered trademark of Steris. Microlube is a registered trademark of PurposeBuilt Brands. Use of these names, trademarks and brands does not imply endorsement. All company, product and service names used in this technology guide are for identification purposes only.