

The *multiSTATION*[®] *SubX*[™] *STERNAL ASCENDER*[™] SYSTEM and *LITA/RITA RetroSterno*[™] *FLAT PADDLES*

Technology Guide

 READ THIS PRODUCT INSERT THOROUGHLY BEFORE USE

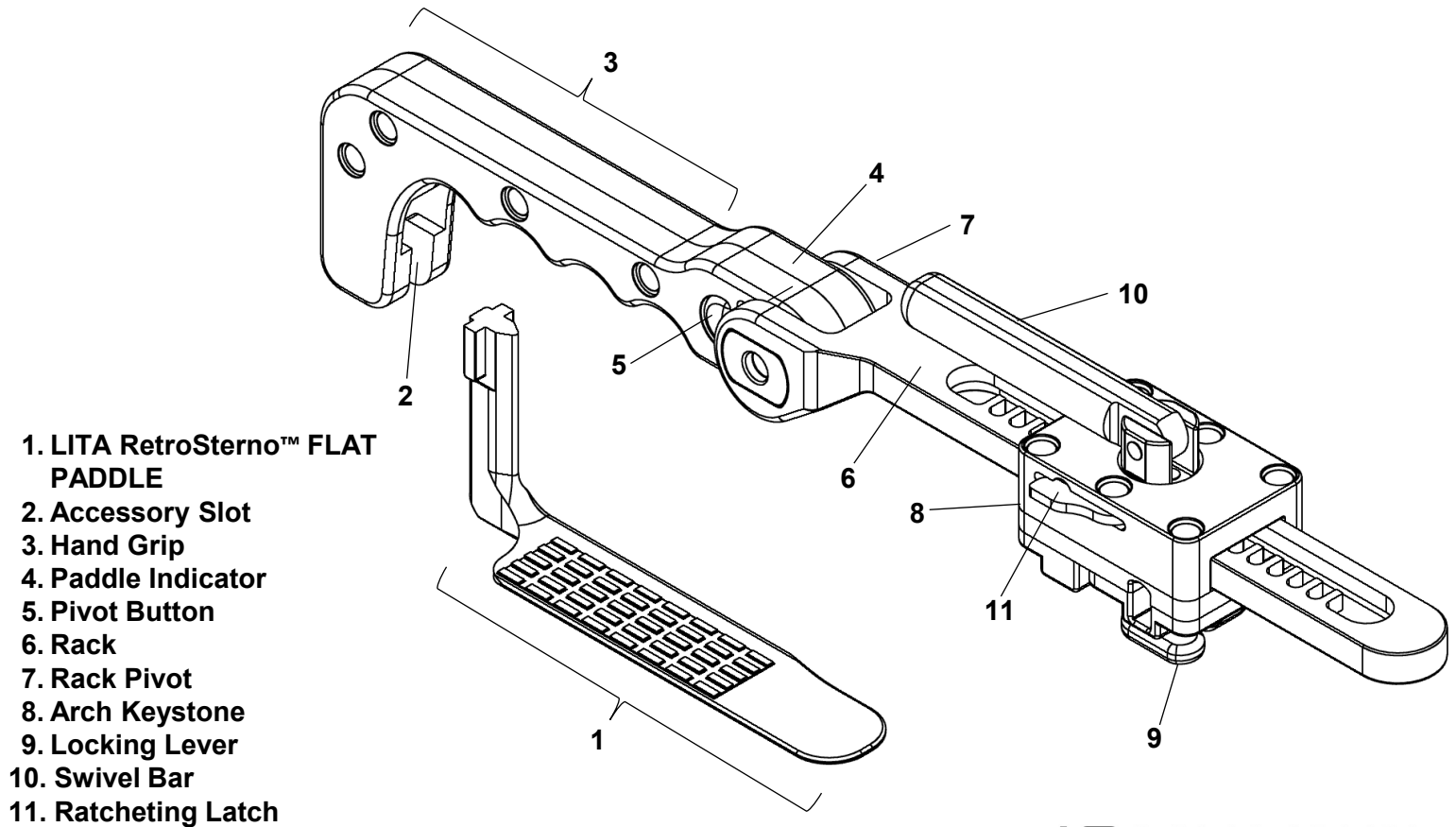

FIG. 1 –*SubX*[™] *STERNAL ASCENDER*[™] SYSTEM 

***multiSTATION*[®] *SubX*[™] *STERNAL ASCENDER*[™] SYSTEM DEVICE DESCRIPTION:**

The *SubX*[™] *STERNAL ASCENDER*[™] SYSTEM (FIG. 1) is a reusable mechanical hoist mechanism that provides elevation of a selected accessory (sold separately) when configured with compatible *RIGID miniARM*[®]s and *multiSTATION*[®] *RAIL CLAMPS*. The selected accessory, *LITA RetroSterno*[™] *FLAT PADDLE* 1 shown as an example above, is loaded into the accessory slot 2 and secured by pulling down. The hand grip 3 provides an ergonomic handle to insert and manipulate the accessory extracorporeally and create initial retraction. The paddle indicator 4 indicates the location of the tip of the *RetroSterno*[™] *Paddle* during placement. The pivot button 5 is pressed to unlock the system and allow rotation of the rack 6 about the rack pivot 7. Once the rack is oriented as desired, the pivot button is pressed again to lock the angular position of the rack. The arch keystone 8 includes two attachment points into which two *RIGID miniARM*[®]s (not shown) are inserted to establish the bridge configuration. Two locking levers 9 rotate to secure and release the *miniARM*[®] quick connect posts to the arch keystone or remove them from the arch keystone. The swivel bar 10 is rotated counterclockwise to raise the system. Every half turn, the ratcheting latch 11 engages an anti-backdrive feature in the arch keystone. An audible click indicates that the locking feature has been activated and secure elevation has been achieved. Upon completion of the procedure, the ratcheting latch is pressed and held to bypass the anti-backdrive mechanism. The swivel bar is rotated clockwise to release the load and lower the system.

INDICATIONS FOR USE:

The *multiSTATION*[®] *SubX*[™] *STERNAL ASCENDER*[™] SYSTEM is indicated for use by surgeons to hold instruments in a fixed position for a period of time.

INSTRUCTIONS FOR USE

ATTACHING, PIVOTING, RAISING, and LOWERING the *multiSTATION*[®] *SubX*[™] *STERNAL ASCENDER*[™] SYSTEM

Prior to each use, test the *SubX*[™] *STERNAL ASCENDER*[™] SYSTEM by confirming that the arch keystone can travel the entire length of the rack. Discontinue use if the arch keystone binds at any point along the rack. Steps 1-4 show a *LITA RetroSterno*[™] *FLAT PADDLE* as an example of a compatible accessory. Accessories available separately.

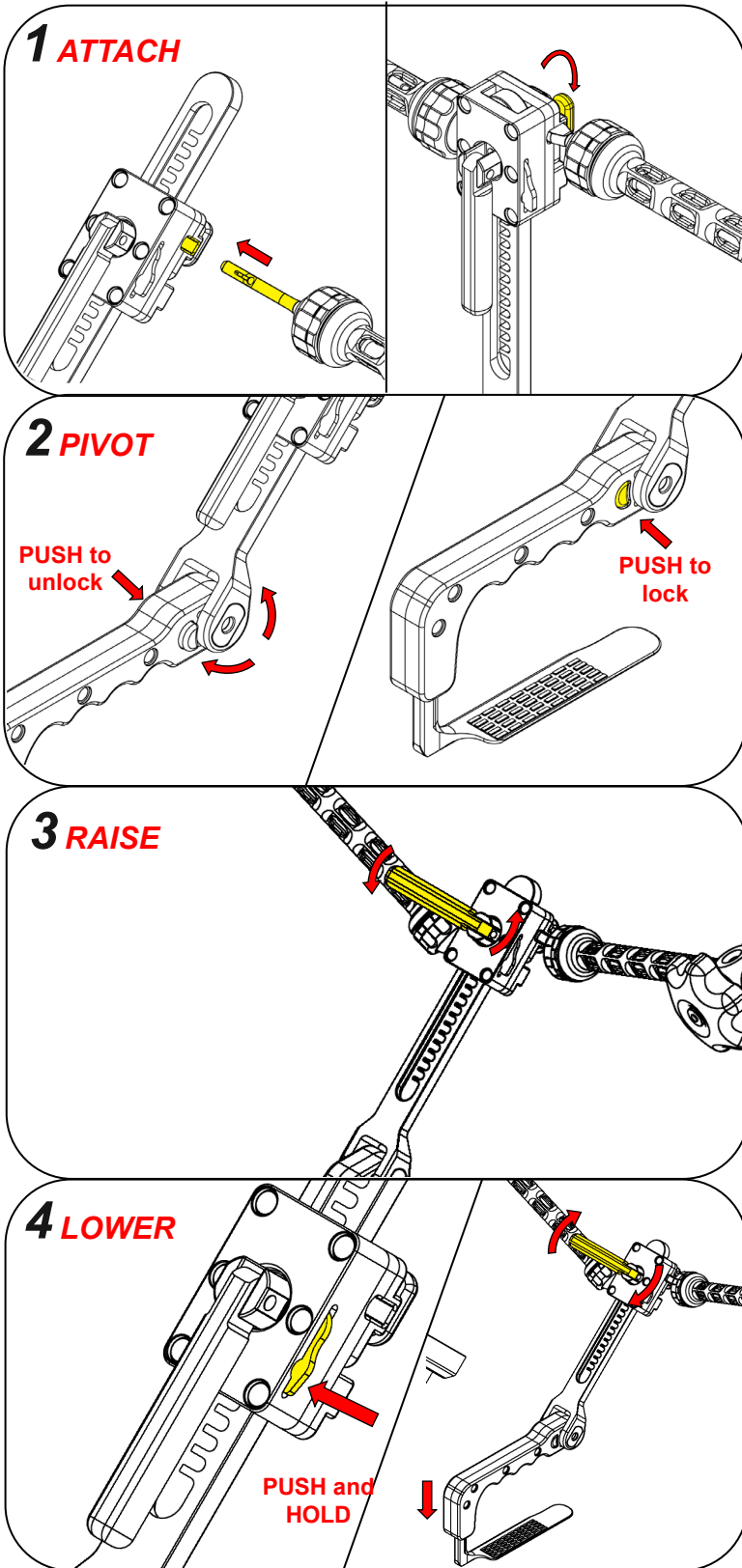

1. **ATTACH** the ascender to two holders by inserting the quick connect posts into the arch keystone and rotating the locking levers to the locked position.

2. **PIVOT** the hand grip about the rack while the pivot button is disengaged. Engage the pivot button to lock the angle of the hand grip.

3. **RAISE** the hoist mechanism by rotating the swivel bar counterclockwise.

NOTE: Ensure that the swivel bar is rotated until an audible click is heard, indicating that the arch keystone is locked in position.

4. **LOWER** the hoist mechanism by rotating the swivel bar clockwise while pressing the ratcheting latch.

NOTE: The swivel bar cannot rotate clockwise without the ratcheting latch disengaged.

The *multiSTATION*[®] *SubX*[™] *STERNAL ASCENDER*[™] *SYSTEM* and *LITA/RITA RetroSterno*[™] *FLAT PADDLES*

Technology Guide

 READ THIS PRODUCT INSERT THOROUGHLY BEFORE USE

1. *LITA RetroSterno*[™] *FLAT PADDLE*
2. *RITA RetroSterno*[™] *FLAT PADDLE*
3. Textured Zone
4. Paddle Post
5. Attachment Stud

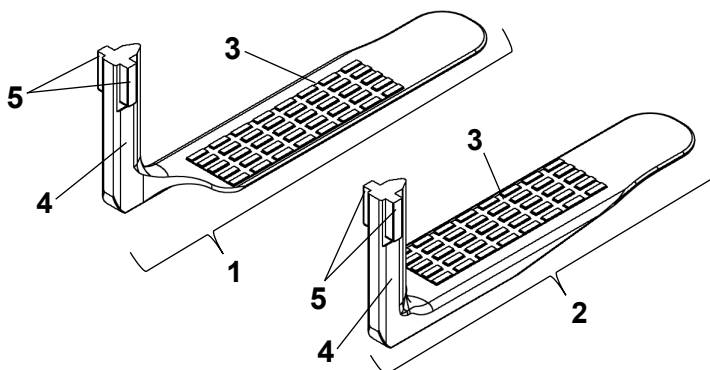

FIG. 2 – *LITA/RITA RetroSterno*[™] *FLAT PADDLES* 

***multiSTATION*[®] *LITA/RITA RetroSterno*[™] *FLAT PADDLE* DEVICE DESCRIPTION:**

The non-sterile, reusable *LITA RetroSterno*[™] *FLAT PADDLE* and *RITA RetroSterno*[™] *FLAT PADDLE* (FIG. 2) are accessories to the *SubX*[™] *STERNAL ASCENDER*[™] *SYSTEM*. The *LITA RetroSterno*[™] *FLAT PADDLE* 1 provides retraction of the sternum and sub-xiphoid access to the left internal mammary artery. The *RITA RetroSterno*[™] *Paddle* 2 provides retraction of the sternum and sub-xiphoid access to the right internal mammary artery. The textured zone 3 provides grip on the sub-sternal tissue during retraction. The *RetroSterno*[™] *Paddles* are offset laterally to maximize working space and concavely contoured to facilitate optimal visualization of the targeted vessel. The shape of the paddle post 4 interfaces with space lateral to the xiphoid process and opposite the targeted internal mammary artery to create a low-profile anatomical insertion. The attachment studs 5 allow for quick connection to the accessory slot of the *SubX*[™] *STERNAL ASCENDER*[™] *SYSTEM*.

INDICATIONS FOR USE:

The *multiSTATION*[®] *LITA RetroSterno*[™] *FLAT PADDLE*/*multiSTATION*[®] *RITA RetroSterno*[™] *FLAT PADDLE* is indicated for use for retraction of bone and soft tissue.

1 SELECT

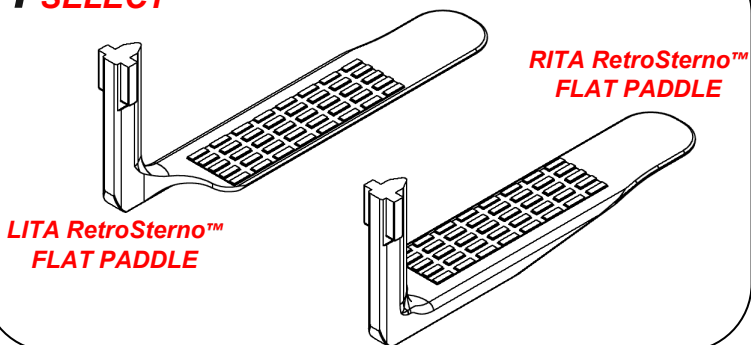

1. **SELECT** the LITA paddle for access to the left internal mammary artery or the RITA paddle for access to the right internal mammary artery.

2 ATTACH

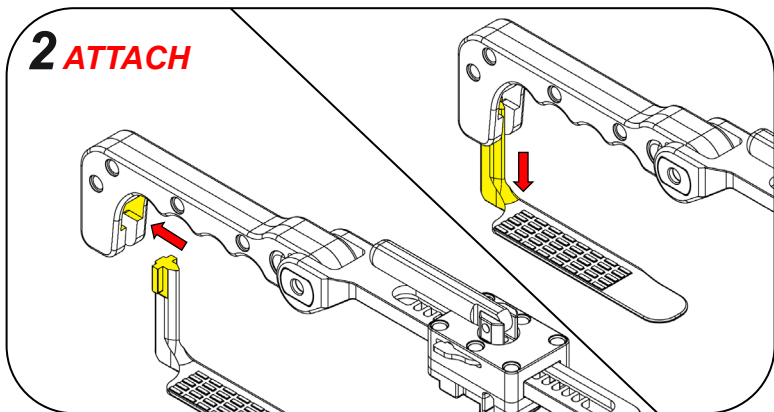

2. **ATTACH** a paddle by inserting the paddle post into the accessory slot of the hand grip and pulling down to secure.

INSTRUCTIONS FOR USE

SETTING UP, ATTACHING, and POSITIONING the multiSTATION® Bridge

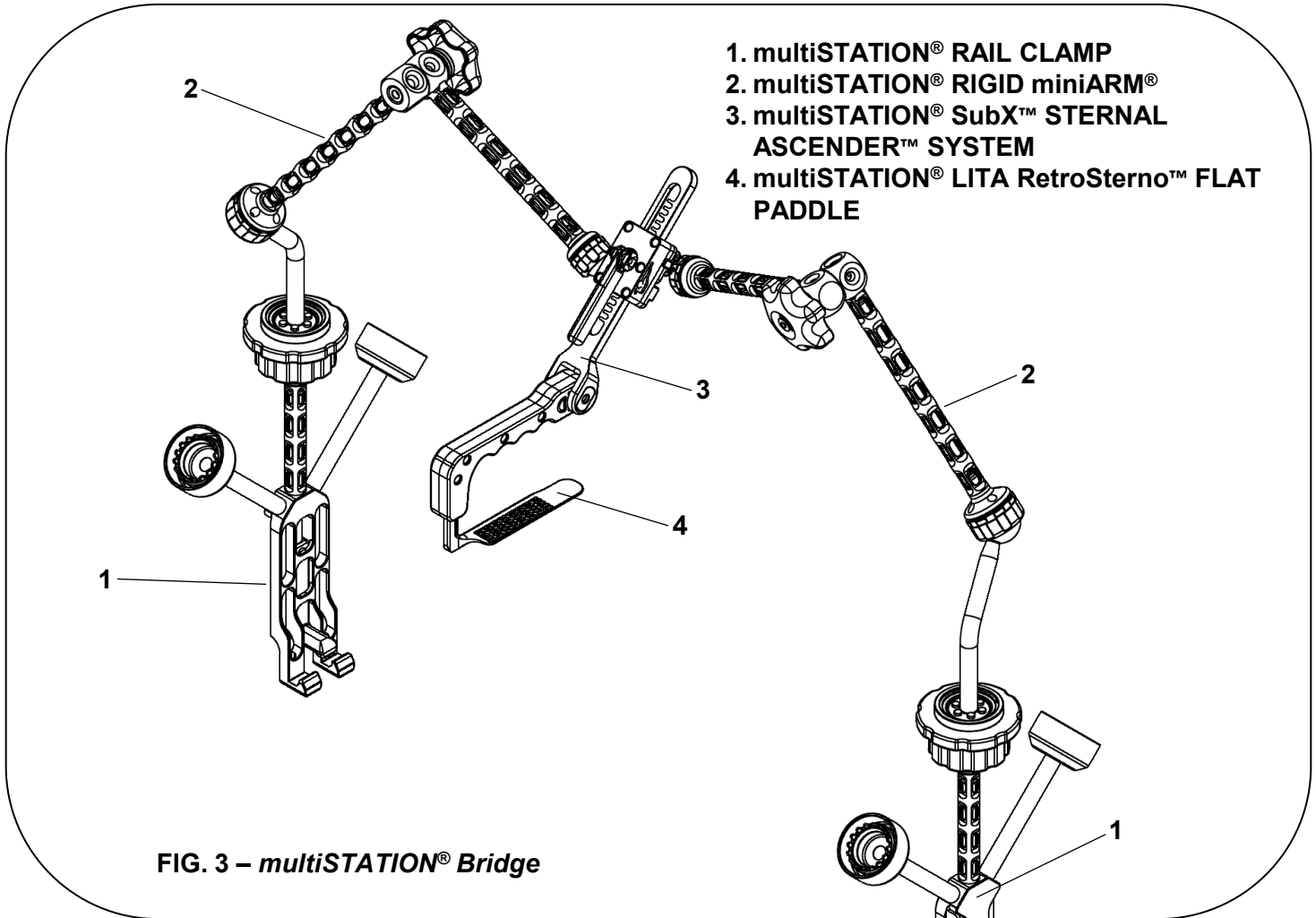

multiSTATION® Bridge DESCRIPTION:

The *multiSTATION® Bridge* (FIG. 3) comprises two *RIGID miniARM®*s, two *RAIL CLAMPS*, a *SubX™ STERNAL ASCENDER™ SYSTEM*, and a compatible accessory such as a *LITA RetroSterno™ FLAT PADDLE*.

The bridge is assembled by attaching the rail clamps to draped surgical table rails, connecting a holder to the rail clamp, and then connecting the ascender to the holders. This configuration provides a stable, rigid system with which compatible accessories may be securely raised and lowered. The holders may be connected to either a side or center receiving DOC of the rail clamp to provide positional adjustability. The ascender, with a compatible accessory attached, is connected to the two holders and adjusted into position. Once the desired position of the bridge is reached, the system is locked into place. The swivel bar is used to raise the compatible accessory, providing a stable opening to the surgical site. The accessory paddle can be lowered by rotating the swivel bar clockwise while pressing the ratcheting latch. The bridge can then be repositioned, or a different accessory paddle can be installed.

INSTRUCTIONS FOR USE

SETTING UP, ATTACHING, and POSITIONING the multiSTATION® Bridge

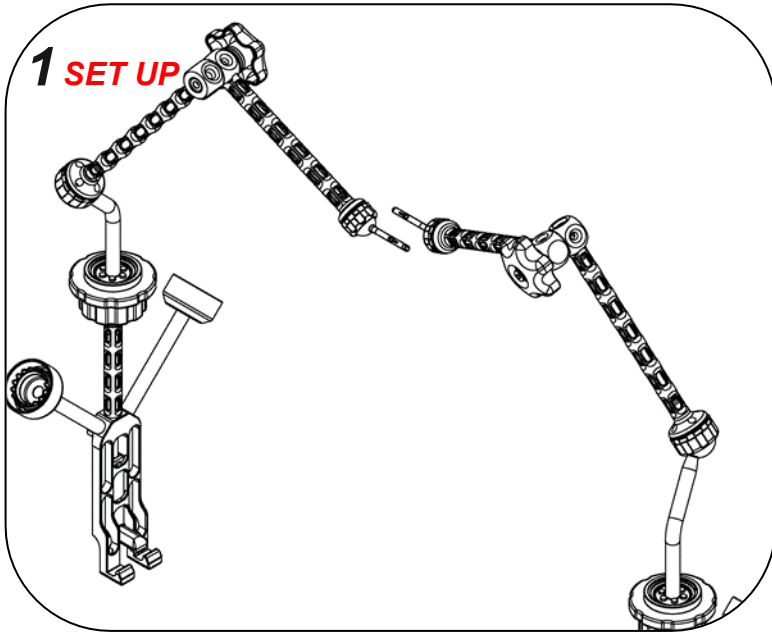

1. SET UP two rail clamps and two miniARM®s on opposite surgical table rails. See each device's instructions for use for more information.

NOTE: Fully tighten the rail clamps to the surgical table rails. Do not fully lock the holders.

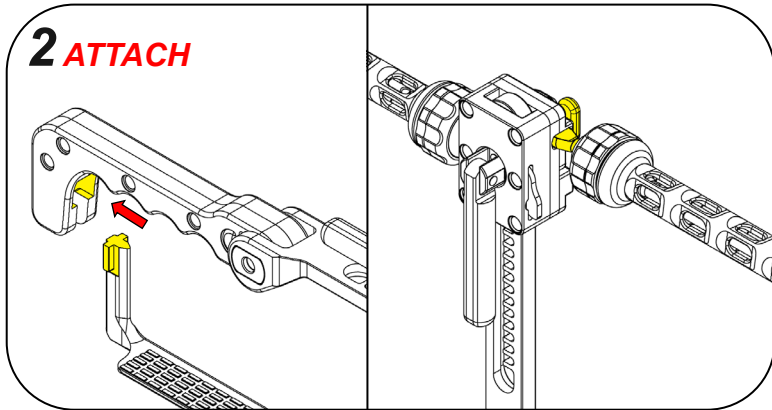

2. ATTACH a paddle to the ascender and connect the arch keystone to the miniARM®s.

NOTE: Ensure that the arch keystone is at the top of the rack to allow for maximum retraction.

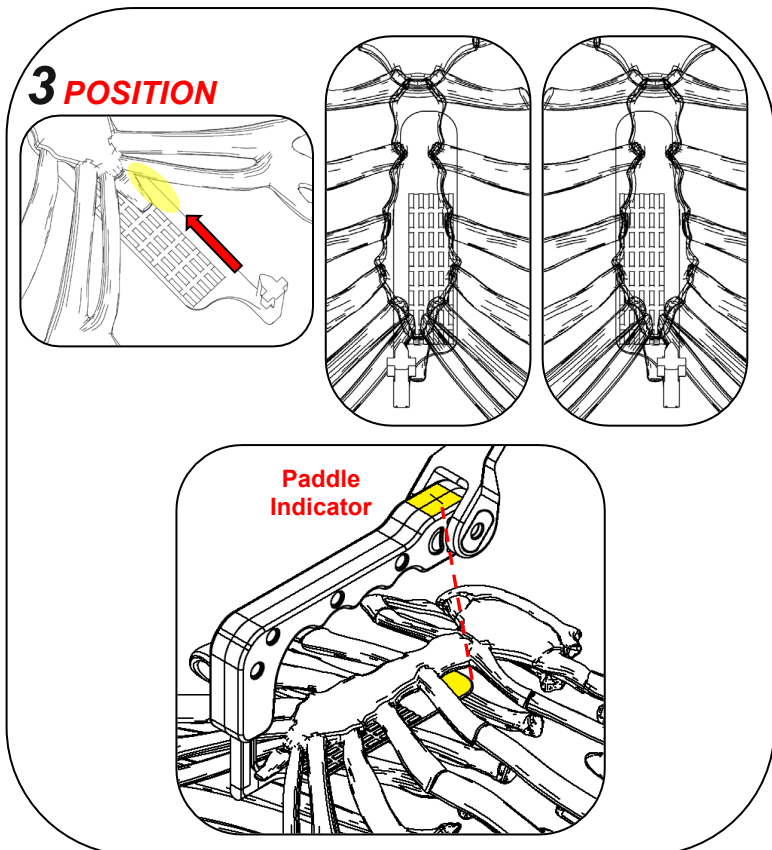

3. POSITION the paddle by adjusting the ascender and/or the holders. The paddle post should interface with the space lateral to the xiphoid process, opposite the targeted internal mammary artery.

NOTE: The paddle indicator on the top of the hand grip represents the location of the tip of the paddle. The paddle should always be kept parallel to the sternum.

INSTRUCTIONS FOR USE

LOCKING, LIFTING, AND RELEASING the *multiSTATION*[®] *SubX*[™] *STERNAL ASCENDER*[™] SYSTEM

1 LOCK

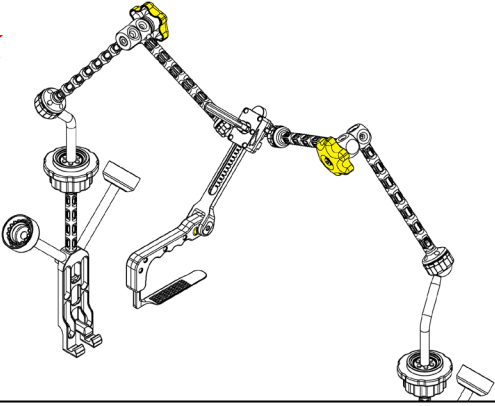

1. **LOCK** the bridge in place by rotating the holder adjustment knobs clockwise until fully tightened and engaging the pivot button.

NOTE: Verify that the bridge's position is secure before proceeding.

2 LIFT

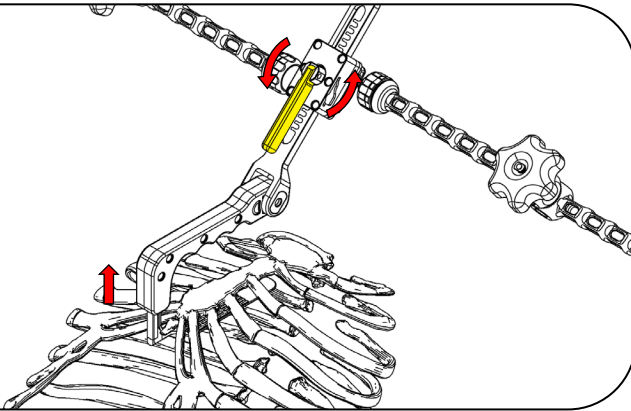

2. **LIFT** the sternum by rotating the swivel bar counterclockwise until sufficient visualization of the surgical site has been achieved.

NOTE: An audible click indicates that the locking feature is engaged.

3 RELEASE

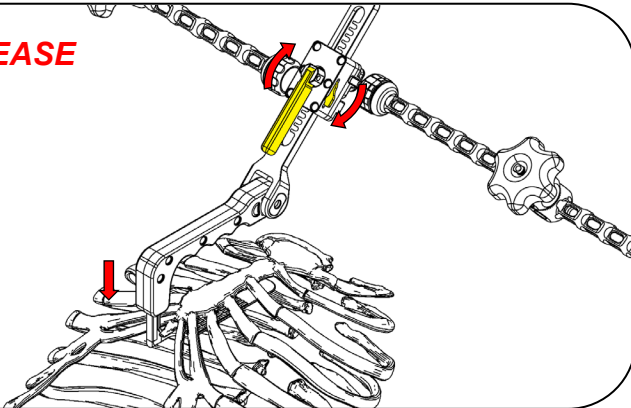

3. **RELEASE** the system by rotating the swivel bar clockwise while pressing the ratcheting latch. With the system fully lowered, the paddle can be removed or swapped.

NOTE: Do not attempt to remove a paddle or reposition the bridge while the sternum is still under load.

REMOVAL and CLEANUP

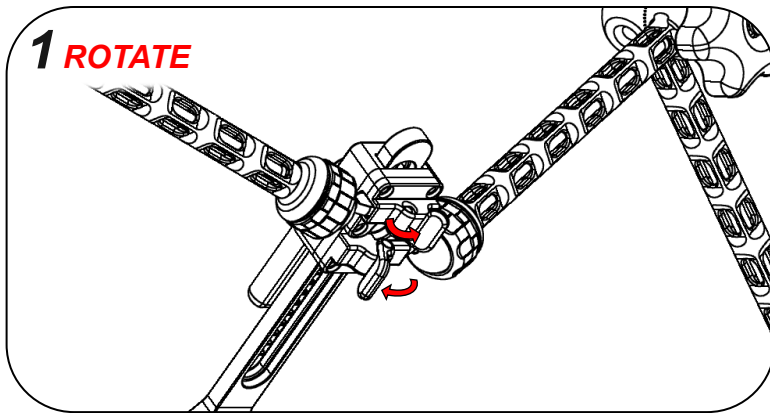

1. **ROTATE** the locking levers of the ascender to the unlocked position.

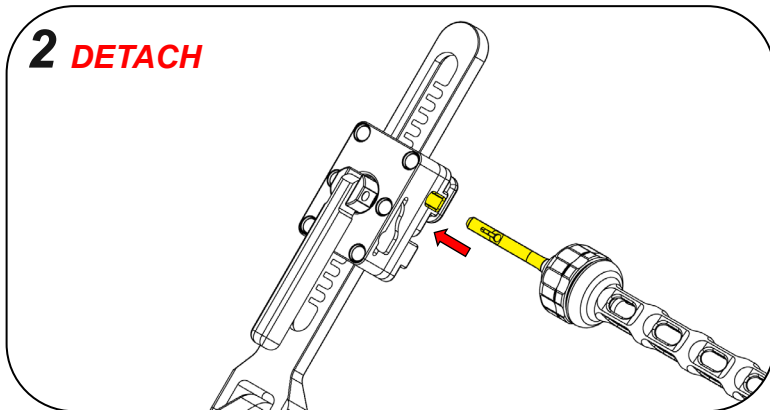

2. **DETACH** the ascender by sliding it off both of the quick connect posts.

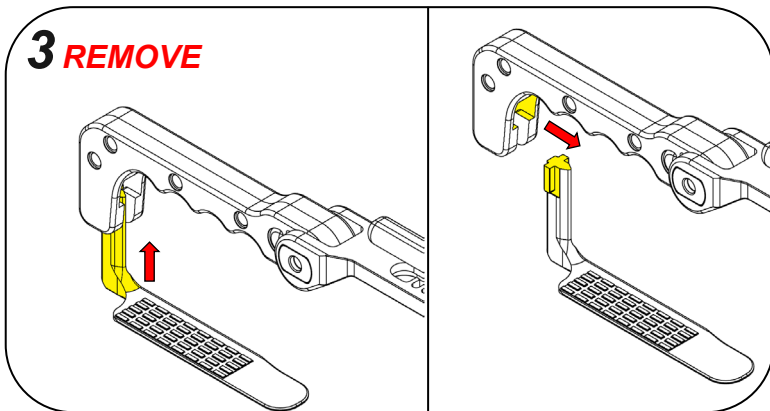

3. **REMOVE** the paddle by lifting the post up and out of the accessory slot of the hand grip.

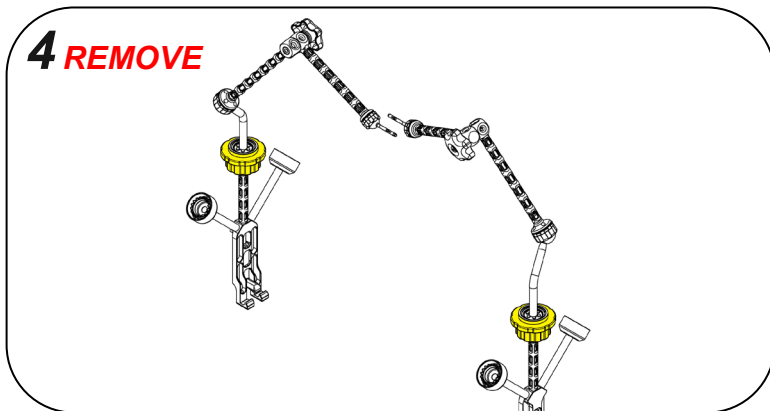



4. **REMOVE** the holders and rail clamps according to each device's instructions for use.

NOTE: Fully support the miniARM® while removing it from the rail clamps. Removal of the holder may be eased by keeping the holder in its locked position.

multiSTATION® SubX™ STERNAL ASCENDER™ SYSTEM REPROCESSING

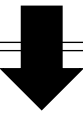
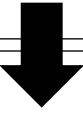
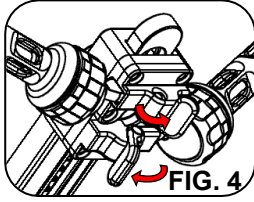
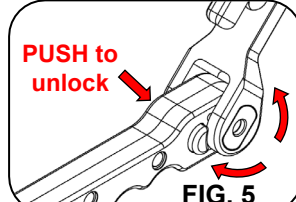
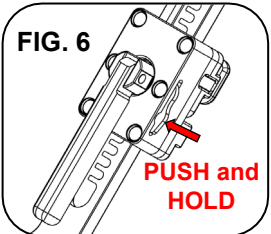
- Disassemble and clean the device immediately after use. Do not allow a soiled device to dry.
- The SubX™ STERNAL ASCENDER™ SYSTEM is not validated to be cleaned or sterilized with an accessory attached.
- Cleaning agent used in validation: Steris Prolystica® 2X (enzymatic, neutral pH).
- Perform the final rinse using only freshly prepared purified water/highly purified water.
- Never use metal brushes or steel wool for cleaning.
- Prepare and reprocess any holder or rail clamp according to each device's instructions for use.
- This device is unaffected by pressure changes associated with reprocessing.
- The sterilization tray is NOT designed for cleaning devices. It must be processed separately. The tray is only intended for sterilization, transport, and storage of reusable instruments. For more tray information, see the sterilization tray instructions for use.

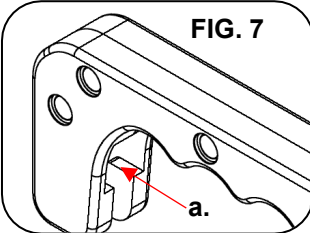
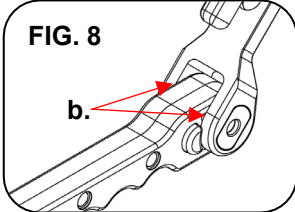
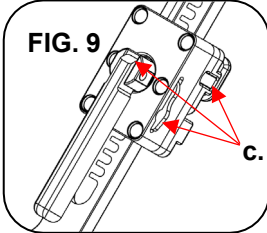
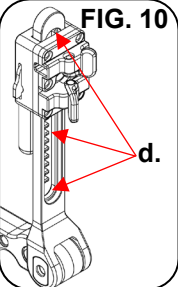
<p>POINT OF USE</p> 	<ol style="list-style-type: none"> 1. Disassemble and clean device immediately after use. 2. Do not allow soiled devices to dry.
<p>PREPARATION</p> 	<ol style="list-style-type: none"> 1. Remove the ascender from the two miniARM®s by rotating the locking levers and sliding the device off the quick connect posts (FIG. 4). 2. Push the pivot button to the unlocked position to allow the hand grip to freely rotate (FIG. 5). 3. Rotate the swivel bar to position the arch keystone approximately in the middle of travel along the rack. Press and hold the ratcheting latch to rotate the swivel bar clockwise. (FIG. 6). 4. If using the multiSTATION® Sterilization Tray (Part Number 100034), clean the tray separately according to the sterilization tray instructions for use.   
<p>MANUAL PRE-CLEANING</p> 	<ol style="list-style-type: none"> 1. Soak in enzymatic, neutral pH cleaning solution for a minimum of 5 minutes. Refer to detergent manufacturer's instructions for temperature and concentration. 2. Use a plastic-bristled brush to thoroughly scrub the device's exterior surfaces, paying special attention to the following: <ol style="list-style-type: none"> a. Accessory slot (FIG. 7) b. Rack pivot and pivot button (FIG. 8) c. Arch keystone, including swivel bar, ratcheting latch, and attachment opening (FIG. 9) d. Front and back of the rack, rack teeth (FIG. 10) 3. Rinse with warm water (38–45°C [100–113°F]) for a minimum of 2 minutes. 4. Proceed with one of the two required cleaning options: ultrasonic or automated.    

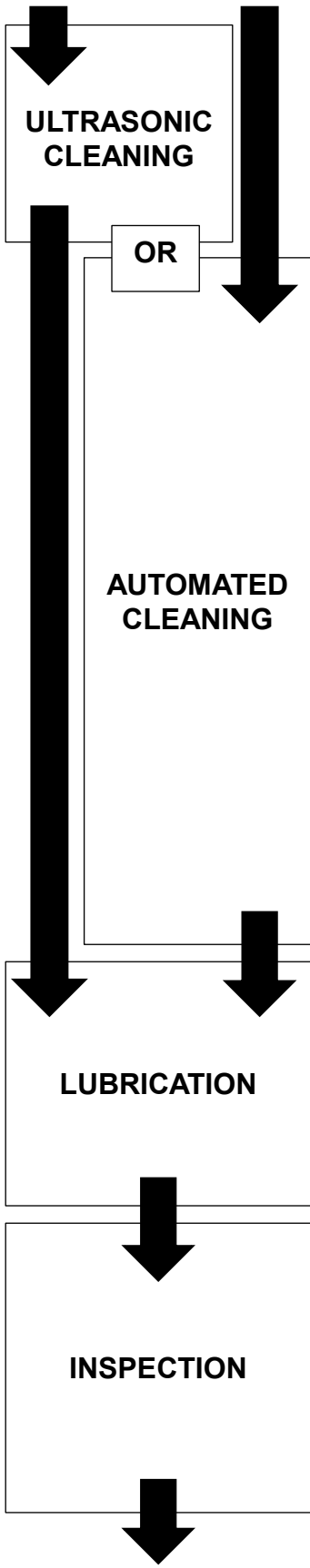

1. Clean in ultrasonic bath with enzymatic, neutral pH cleaning solution for a minimum of 15 minutes. Refer to detergent manufacturer's instructions for temperature and concentration.
2. Rinse with warm water (38–45°C [100–113°F]) for a minimum of 4 minutes. To ensure a complete rinse, use a clean plastic-bristled brush to scrub the device.

1. A washer-disinfector with fundamentally approved efficiency (e.g., according to EN ISO 15883) is required and it must be properly installed, qualified, and regularly subjected to maintenance and testing.
2. Load the device into the washer-disinfector. Avoid contact between devices and arrange to allow for proper drainage.
3. Operate the washer-disinfector cycle with an additional rinse cycle.
4. The following minimum parameters were validated as effective for cleaning this device in an automated washer:

Treatment	Time (mm:ss)	Temperature °C (°F)	Additive
Pre-wash (Cold tap)	2:00	17 (63)	N/A
Wash (Hot tap)	2:00	40 (104)	Steris Prolystica® 2X
Rinse	2:00	70 (158)	N/A
Rinse	2:00	70 (158)	Optional lubricant
Dry	15:00	80 (176)	N/A

1. Apply instrument lubricant mixed to manufacturer's recommendations to prolong instrument life by submerging the entire device in the lubricant for a minimum of 30 seconds. If the hospital washer-disinfector has a lubrication cycle this can be used instead of manual lubrication.
- NOTE:** LSI has validated the use of MicroLube™ C Instrument Lubricant on this device. Other instrument lubricant brands have not been tested and performance and results cannot be guaranteed.

1. Carefully inspect the device to assure that all visible soil has been removed. Generally, unmagnified visual inspection under good light conditions is sufficient. Particular attention should be paid to the locations in FIG. 7-10. Repeat cleaning process if soil is detected.
2. Visually inspect the device for mild or excessive corrosion. If corrosion is present, discontinue use of the device in surgery, but complete reprocessing.
3. Visually inspect the device for any damage. If parts are damaged, discontinue use of the device in surgery, but complete reprocessing.

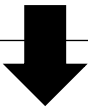

PACKAGING

1. Ensure that the ascender pivot button is pushed to unlock and that the hand grip rotates freely.
2. If using a sterilization pouch, place each instrument in its own individual pouch. If using a sterilization tray, read the sterilization tray instructions for use before proceeding. Ensure that the sterilization tray has been cleaned according to the sterilization tray instructions for use and load the tray bottom according to FIG. 11.
3. Package the device according to TABLE 1. The barrier system for sterilized re-usable instruments should meet the following requirements:

- ISO 11607-1
- Suitable for pre-vacuum steam sterilization
- Appropriate for medical use
- Grade appropriate for weight of loaded tray per sterilization tray instructions for use and facility procedures

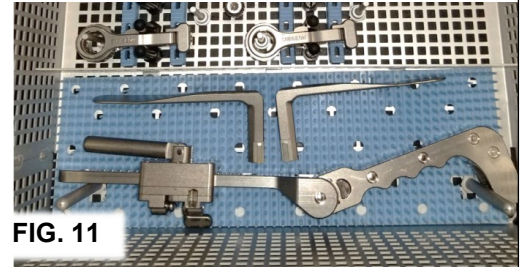
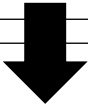

FIG. 11



STERILIZATION

1. The device must be properly cleaned prior to sterilization.
2. Perform sterilization cycle according to TABLE 1:

Method	Moist heat (steam) sterilization according to ANSI/AAMI ST79	Moist heat (steam) sterilization according to ANSI/AAMI ST79	Immediate use steam sterilization according to ANSI/AAMI ST79
Container	<i>multiSTATION</i> [®] <i>Sterilization Tray</i> P/N 100034	No tray	No tray
Cycle	Pre-vacuum (Pre-vac)	Pre-vacuum (Pre-vac)	Pre-vacuum (Pre-vac)
Packaging	2-layer polypropylene wrap	Pouch	No packaging
Temperature	132-137°C (270–279°F)	132-137°C (270–279°F)	132-137°C (270–279°F)
Exposure Time	4– 18 minutes	4– 18 minutes	4– 18 minutes
Dry Time	65 minutes (minimum)	25 minutes (minimum)	N/A

Device(s) processed by immediate use sterilization should be transferred immediately, using aseptic technique, from the sterilizer to the point of use.

Refer to ANSI/AAMI ST79, Comprehensive Guide to Steam Sterilization and Sterility Assurance in Health Care Facilities.

The *SubX*[™] *STERNAL ASCENDER*[™] *SYSTEM*, *LITA RetroSterno*[™] *FLAT PADDLE*, and *RITA RetroSterno*[™] *FLAT PADDLE* have been validated to 20 reprocessing cycles. The useful lifespan of a surgical instrument is largely dependent on the care and handling of the instrument. Careful inspection and functional testing of the instrument should be used to determine the end of its serviceable life.

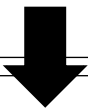

STORAGE

1. During storage, ensure the device remains in a sterile condition ready for reuse.
2. Shelf life is dependent on the sterile barrier employed, storage manner, and environmental and handling conditions.

CONTRAINDICATIONS

- Do not use with attachments other than accessories provided by LSI SOLUTIONS®.
- These devices are not intended for use except as indicated.

WARNINGS

- Federal law restricts this device to sale, distribution, and use by, or on, the order of a physician.
- Read and become familiar with all instructions, warnings, and cautions before using this product.
- The *SubX™ STERNAL ASCENDER™ SYSTEM*, *LITA RetroSterno™ FLAT PADDLE*, and *RITA RetroSterno™ FLAT PADDLE* shall be used in accordance with these instructions for use.
- Improper use of the *SubX™ STERNAL ASCENDER™ SYSTEM*, *LITA RetroSterno™ FLAT PADDLE*, and *RITA RetroSterno™ FLAT PADDLE* may cause serious injury or death. In addition, improper care and maintenance of the device may render the device non-sterile prior to patient use and may cause serious injury to the health care provider or the patient.
- When using *SubX™ STERNAL ASCENDER™ SYSTEM*, *LITA RetroSterno™ FLAT PADDLE*, and *RITA RetroSterno™ FLAT PADDLE*, patients must be immobilized or anesthetized.
- Discontinue use of the *SubX™ STERNAL ASCENDER™ SYSTEM*, *LITA RetroSterno™ FLAT PADDLE*, and *RITA RetroSterno™ FLAT PADDLE* when patient is moving or being moved.
- Do not use this retraction system without adequate knowledge or experience regarding surgical retraction, including sternal and rib retraction. Avoid compressing, tensioning, displacing, or compromising tissue structures, such as the heart, that may be injured or lead to interoperative or postoperative loss of function.
- Surgical or endoscopic procedures should be performed only by physicians having adequate training and familiarity with relevant techniques and anatomy. Medical literature relating to techniques, complications, and hazards should be consulted prior to use.





PRECAUTIONS

- **The *SubX™ STERNAL ASCENDER™ SYSTEM*, *LITA RetroSterno™ FLAT PADDLE*, and *RITA RetroSterno™ FLAT PADDLE* are packaged as non-sterile.** Clean and sterilize prior to use.
- Proper cleaning, sterilization, packaging, storage and deployment are required to ensure sterility and safe use.
- If there are any variations between these instructions for use and the policies of your facility and/or the instructions of your cleaning/sterilizing equipment manufacturer, those variations should be brought to the attention of the appropriate responsible hospital personnel for resolution before proceeding with cleaning and sterilizing your device.
- Use of the *SubX™ STERNAL ASCENDER™ SYSTEM*, *LITA RetroSterno™ FLAT PADDLE*, and *RITA RetroSterno™ FLAT PADDLE* for a task other than what it is intended for can result in a damaged or broken device, and/or injury or death.
- Prior to use, inspect the *SubX™ STERNAL ASCENDER™ SYSTEM*, *LITA RetroSterno™ FLAT PADDLE*, and *RITA RetroSterno™ FLAT PADDLE* to ensure proper function and condition. Do not use devices if they do not satisfactorily perform their intended function or if they have physical damage.
- Ensure operating room table rails are of adequate strength to support use of this system to lift tissue structures as indicated for the individual patient.
- Ensure system connections, fittings and engagement features are secured appropriately, fully and accurately positioned to confer the required function.
- Ensure placement of system components to not compromise patient access during surgery or injure patient or tissue structures.
- Ensure retractors are placed in contact with tissue structures under adequate visualization. Do not force system components against non-targeted tissue.
- Ensure all system components are appropriately removed from the patient and operating room table prior to patient movement.
- Surgical instruments vary between manufacturers. Before instruments and accessories from different manufacturers are employed together in a procedure, verify compatibility and ensure electrical isolation or grounding are not compromised.
- Like all metal implements used in surgery, the components of this system conduct electricity and can be associated with electrical shock or arcing from cautery or other sources of current.
- Avoid mechanical shock or overstressing the *SubX™ STERNAL ASCENDER™ SYSTEM*, *LITA RetroSterno™ FLAT PADDLE*, and *RITA RetroSterno™ FLAT PADDLE*.
- Only the cleaning and sterilization processes that are defined within these instructions for use have been validated.
- Store at room temperature.

ADVERSE REACTIONS

- No documented adverse reactions.
- Any serious incident that has occurred in relation to the device should be reported to the manufacturer and the country competent authority.

ORDERING INFORMATION

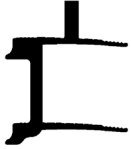
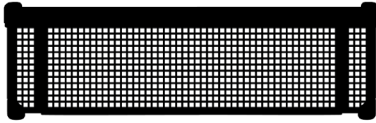
TABLE 2: <i>multiSTATION</i> [®] <i>SubX</i> [™] <i>STERNAL ASCENDER</i> [™] SYSTEM PRODUCT ORDERING			
	REORDER	PRODUCT	DESCRIPTION
	REF 080900	<i>multiSTATION</i> [®] <i>SubX</i> [™] <i>STERNAL ASCENDER</i> [™] SYSTEM	1 Shelf Box
	REF 081214	<i>multiSTATION</i> [®] <i>LITA RetroSterno</i> [™] FLAT PADDLE	1 Shelf Box
	REF 081241	<i>multiSTATION</i> [®] <i>RITA RetroSterno</i> [™] FLAT PADDLE	1 Shelf Box
	REF 081870*	<i>multiSTATION</i> [®] <i>LITA RetroSterno</i> [™] CURVED PADDLE	1 Shelf Box
	REF 081880*	<i>multiSTATION</i> [®] <i>RITA RetroSterno</i> [™] CURVED PADDLE	1 Shelf Box
	REF 081581*	<i>multiSTATION</i> [®] <i>BITA RetroSterno</i> [™] PADDLE	1 Shelf Box
	REF 100034	<i>multiSTATION</i> [®] Sterilization Tray*	1 Shelf Box

*Not CE Marked

LSI SOLUTIONS[®]

LSI SOLUTIONS, Inc.
7796 Victor-Mendon Road
Victor, New York 14564 U.S.A.
Phone: +1 585.869.6600
Customer Service: +1 866.575.3493
Technical Support: +1 866.428.9092
Fax: +1 585.742.8086
www.lsisolutions.com

*The *multiSTATION*[®] Sterilization Tray is manufactured by Summit Medical, 815 Vikings Parkway, Suite 100, St. Paul, MN 55121 U.S.A.

MADE IN THE USA

This Product Comes with our LSI SOLUTIONS[®] **Perfect Performance Policy**[®]. Call us at 866.575.3493 any time.

Patents: www.lsisolutions.com/patents

The LSI logo, LSI Solutions, Perfect Performance Policy, Subx, Click Release, RetroSterno, Sternal Ascender, Miniarm, and Multistation are registered trademarks and trademarks of LSI SOLUTIONS[®].

Copyright © 2021, LSI SOLUTIONS[®]. All Rights Reserved.



Symbol Glossary:
www.lsisolutions.com/symbols



2797

EC REP

Emergo Europe
Westervoortsedijk 60
6827 AT Arnhem
The Netherlands

The Basic UDI-DI for this device is 0850200006multistationDF.

Prolystica is a registered trademark of Steris. MicroLube is a registered trademark of PurposeBuilt Brands. Use of these names, trademarks and brands does not imply endorsement. All company, product and service names used in this technology guide are for identification purposes only.

P/N 081224K 23-JUN-2026