

SPECIFICATION

3CX HYDROGEN BACKHOE LOADER
**THE POWER
TO CHANGE
OUR WORLD**



JCB

STATIC DIMENSIONS

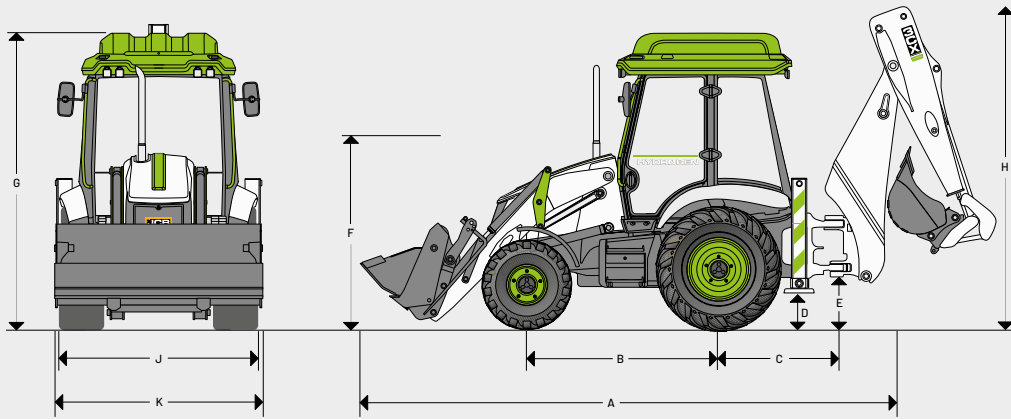

Model	3CX Hydrogen	
	Sideshift	
A Total travel length	m	5.62
B Axle centreline distance	m	2.17
C Slew centre to rear axle centre distance	m	1.36
D Stabiliser feet clearance	m	0.37
E Kingpost clearance		0.52
F Steering wheel centre height	m	1.94
G Cab roof height	m	3.4
H Total travel clearance	m	3.61
J Rear frame width	m	2.35
K Shovel width	m	2.35

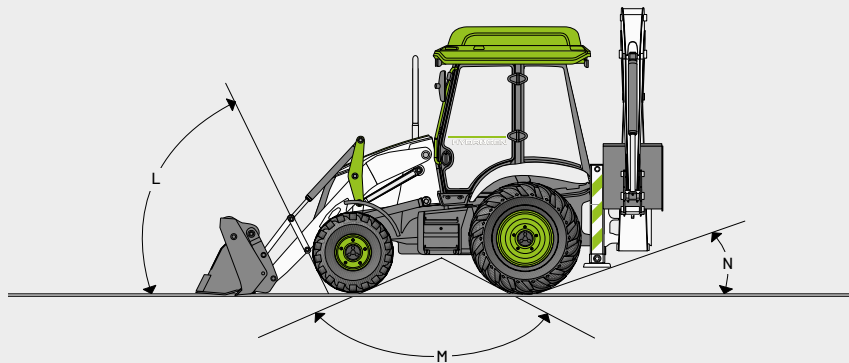

GROUND LINE ANGLES

Model	3CX Hydrogen	
L Approach angle	degrees	66
M Interference angle/ramp to ground plane	degrees	120
N Departure angle	degrees	20

ENGINE

Model	3CX Hydrogen	
Engine Standard	STG V Spark Ignition	
Manufacturer	JCB	
Aspiration	Turbocharged & Intercooled	
Displacement	litre	4.8
No. of Cylinders	4	
Bore	mm	106
Stroke	mm	135
Rated Engine	rpm	2000
Power ratings		
Rated ISO 14396 (SAE J1995 Gross)	kW	55
Maximum torque		
Max torque	Nm	440
Max torque	rpm	1150

ENGINE SUPPORT SYSTEM

Fuel Type	Hydrogen	
Air Cleaner	Dual, dry element type with self cleaning internal air intake precleaner	
Oil filter and lubrication	Full flow, spin-on type filter	
Cooling system	Hot climate specification, pressurised 1.0 Bar suction fan. Pressurised recovery tank with integral filler neck	

TRANSMISSION

Model	3CX Hydrogen	
Manufacturer	JCB	
Type	Autoshift	
Torque Lock	Standard	
Gear 1	kph	5.2
Gear 2	kph	9.5
Gear 3	kph	13.5
Gear 4	kph	19.4
Gear 5	kph	35
Gear 6	kph	40

ELECTRICAL AND INSTRUMENTATION

Camera system	Quick hitch mounted and cab roof camera with 7" colour screen	
7" colour display screen	Audio and phone controls, engine coolant temperature, fuel level, machine hours, help files, service alerts, clock	
Front Display	Speedometer, warning alerts, engine oil, water in fuel, transmission oil temperature and pressure, park brake, air cleaner, alternator	
Battery	1150 CCA (100 amp)	
Horn	Controlled from both front and rear	
Alternator	170 amp	
Front working lights	4 x 1000 lumen LED adjustable lights (standard)	
Rear working lights	4 x 1000 lumen LED adjustable lights (standard)	
Green beacon	Integrated green beacon lights (UK only)	

HYDROGEN BACKHOE LOADER 3CX

FRONT AXLE	
Model	3CX Hydrogen
Type	JCB steer drive with torque proportional
Limited slip	-
Axle ratings	kg
Static load rating	16500
Dynamic load rating	8300
Oscillation angle	16°

REAR AXLE	
Model	3CX Hydrogen
Type	JCB epicyclic hub reduction with torque proportional
Limited slip	Option
Axle ratings	kg
Static load rating	25000
Dynamic load rating	12500

STEERING	
Model	3CX Hydrogen
Axles	Steer drive
Steering turns - lock to lock	2¾
Kerb - kerb turning circle - unbraked	m 8.1
Loader clearance circle - unbraked	m 10.4
Kerb - kerb turning circle - braked	m 6.9
Loader clearance circle - braked	m 9.5

Depending on tyre size, ground conditions etc.

STEERING	
Model	3CX Hydrogen
2WS	✓
AWS	-
Crab steer	-

SERVICE CAPACITIES	
Model	3CX Hydrogen
Cooling system	ltr 18.5
Fuel tank	kg 8.7
Engine oil with filter	ltr 15
Gearbox with filter	ltr 16
Rear axle	ltr 16
Front drive axle	ltr 16
Hydraulic system incl. tank	ltr 117

NOISE AND VIBRATION LEVELS	
Internal dB(A)	70
External dB(A)	100
Vibration m/s ²	2.5m and 0.5m

OPERATING WEIGHTS	
Model	3CX Hydrogen
Extended Dipper	kg 8700

HYDRAULIC SYSTEM	
Piston pump flow	l/min 144
System relief pressure	bar 256
Loader auxiliary flow	l/min 130

Smooth Ride System SRS standard.

STANDARD ACCESSORIES	
Tyres - Michelin XMCL 18/26, Michelin Crossgrip 18/26	
Hydraulics - Bi-directional pipework, Excavator lifting kits for EN474	
Machine features - JCB Power Slide, Integrated quick hitch with forks	
Machine and site protection - Stabiliser street pads	
Attachments - Deep profile excavator bucket (600mm), ditching bucket (1500mm), hydraulic rear quickhitch	

CAB CONFIGURATION	
Seat and comfort	Miscellaneous
Air suspension seat	• Roof mounted camera
Seat head rest	• Quick hitch camera
Arm rest	• Exterior mirrors
Seat belt	• Interior rear view mirror
Heater	• Reverse alarm
Air conditioning	• LED roof beacons
Doors and windows	Controls
Tinted glass	• Joystick FNR switch
Front windscreen wiper	• Return to grade
Rear windscreen wiper	• Return to dig
Rear one piece opening window	• ISO/SAE changeover (Joystick controls)
Door ajar stays	
Steering column	Security
Tilted steering column	• Key Immobiliser
Steering wheel knob	• LiveLink (region specific)
Automatic cab interior light	• Rear light guards
Storage	• Front bumper protection
Side storage & roof storage (lockable)	• End boom damping
	• Standard
Radio	
Bluetooth, USB aux, SD & speakers, integrated hands free phone system	•

LOADER DIMENSIONS

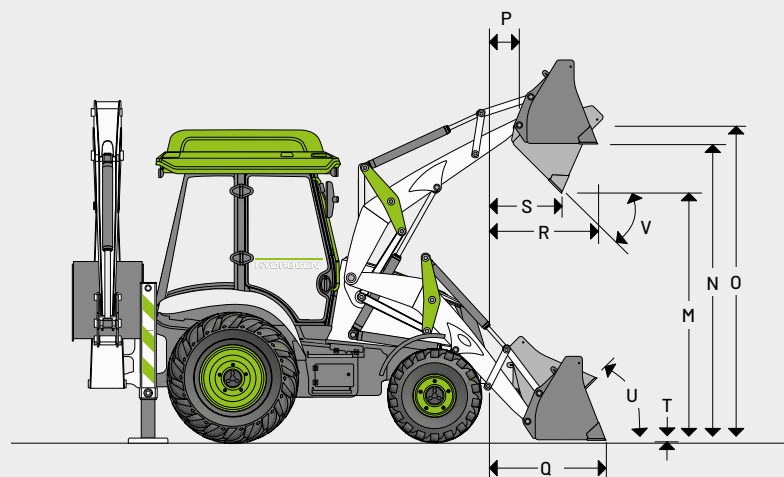

Model		3CX Hydrogen	
		6-in-1 shovel	
M	Dump height	m	2.72
N	Load over height	m	3.20
O	Loader hinge pin height	m	3.45
P	Pin forward reach	m	0.36
Q	Reach at ground (toe plate horizontal)	m	1.42
R	Max. reach at full height	m	1.15
S	Reach at full height fully dumped	m	0.83
T	Dig depth	m	0.07
U	Roll back at ground	degrees	45
V	Dump angle	degrees	43
	Jaw opening width	m	0.95

LOADER PERFORMANCE

Model		3CX Hydrogen	
		6-in-1 shovel	
	Loader breakout - shovel	kgf	6531
	Loader breakout - arms	kgf	4732
	Rated operating capacity 7'8"	kgf	3169
	Rated operating capacity	kg	-
	Clamping force	kgf	2940

*Rated operating capacity as determined according to ISO 14397: 2007

LOADER ATTACHMENTS – FORKLIFT PERFORMANCE DATA

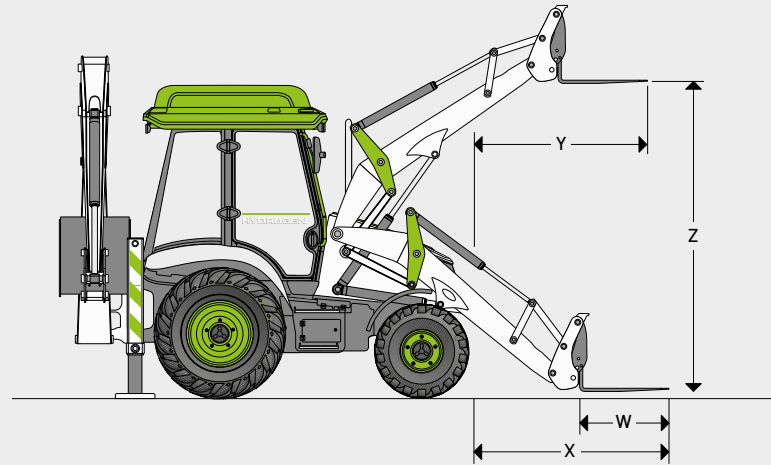

Model		3CX Hydrogen	
		Quickhitch mounted forks	
W	Forks – tine length	m	1.10
	Forks – tine width	m	0.08
X	Forks reach at ground level	m	1.95
Y	Forks reach at full height	m	1.73
Z	Forks lift height – max	m	3.25
	Fork spacing – min	m	0.38
	Fork spacing – max	m	1.36
	SWL @ 500mm load centres	kg	2000

*Dimensions dependent on tyre options

LOADER ATTACHMENTS – DIRECT MOUNT

		Capacity SAE	
		6 in 1	
Width mm (ft-in)	Rated m ³	Struck	
2350 (7-8)	1.20	1.02	

BACKHOE DIMENSIONS

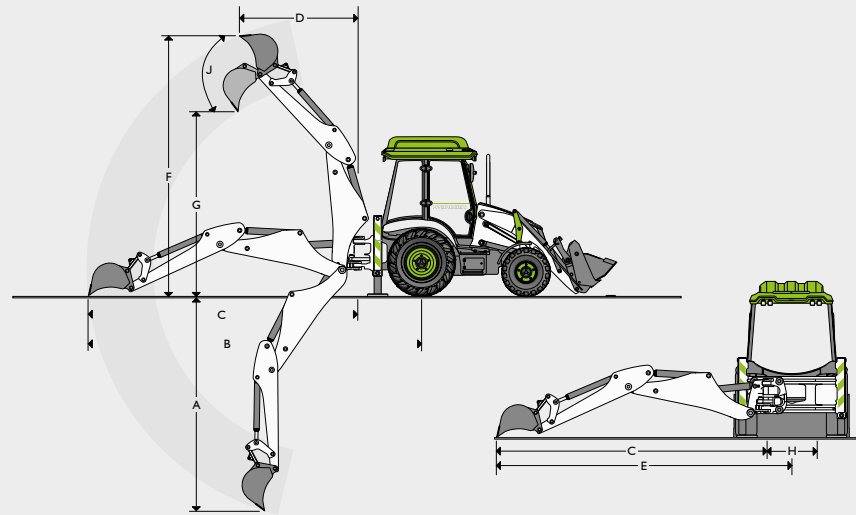

Model				3CX Hydrogen	
				Extradig	
A	SAE max dig depth	m	Ext	5.46	
			Ret	4.24	
	SAE 2ft flat bottom	m	Ext	5.42	
			Ret	4.21	
	Maximum dig depth with deep profile bucket	m	Ext	5.97	
			Ret	4.75	
B	Reach - ground level to rear wheel centre	m	Ext	7.87	
			Ret	6.72	
C	Reach - ground level to slew centre	m	Ext	6.52	
			Ret	5.37	
D	Reach - at full height to slew centre	m	Ext	3.66	
			Ret	2.74	
E	Side reach - to centre line of machine	m	Ext	7.09	
			Ret	5.94	
F	SAE operating height	m	Ext	6.35	
			Ret	5.53	
G	Maximum loadover height	m	Ext	4.72	
			Ret	3.84	
	SAE loadover height	m	Ext	4.32	
			Ret	3.40	
H	Total kingpost travel	m		1.16	
			Narrow rear frame option	m	1.05
J	Bucket rotation	degrees		201	

HYDROGEN BACKHOE LOADER 3CX

BACKHOE PERFORMANCE

Model		3CX Hydrogen	
		Extradig	
Bucket tearout	kgf	Speed	5385
		Power	6228
Dipper tearout	kgf	Ext	2255
		Ret	3225
Lift capacity of bucket pivot at full reach	kg	Ext	719
		Ret	1451

BACKHOE ATTACHMENTS – HEAVY DUTY PROFILE BUCKET

Model		3CX Hydrogen		
Width*		Capacity SAE		Weight (+ Teeth)
mm	Rated m ³	Struck m ³	kg	Teeth
610	0.23	0.18	142	4

* Including sidecutters. Width less sidecutters deduct 25mm (1in).

DITCHING BUCKETS

Model		3CX Hydrogen		
Width*		Capacity SAE		Weight
mm	Rated m ³	Struck m ³	kg	
1525	0.22	0.155	150	

3CX HYDROGEN BACKHOE LOADER

THE POWER TO CHANGE OUR WORLD

JCB, Rokester, Staffordshire, United Kingdom ST14 5JP. Tel: +44 (0)1889 590312. salesinfo@jcb.com. www.jcb.com

©2026 JCB Sales. All rights reserved. No part of this publication may be reproduced, stored in a retrieval system, or transmitted in any form or by any other means, electronic, mechanical, photocopying or otherwise, without prior permission from JCB Sales. All references in this publication to operating weights, sizes, capacities and other performance measurements are provided for guidance only and may vary dependant upon the exact specification of machine. They should not therefore be relied upon in relation to suitability for a particular application. Guidance and advice should always be sought from your JCB Dealer. JCB reserves the right to change specifications without notice. Illustrations and specifications shown may include optional equipment and accessories. The JCB logo is a registered trademark of J C Bamford Excavators Ltd.

33895 en-GB Issue 2



**DISCOVER
MORE**

