

Spiro Ekon 450M3 Electric Motorcycle

Spiro Ekon 450M3 Electric Motorcycle Instruction Manual

Proper use, storage and maintenance can reduce vehicle breakdowns, maintain optimal vehicle performance and extend the service life of the vehicle!

Before riding, please fully understand the performance of this vehicle!

Please read this instruction manual carefully and keep it for future reference!

DIRECTORY

| | |
|---|----|
| 1.Product Overview | 01 |
| 2.Operation Instruction | 02 |
| 3.Parts Description | 03 |
| 4.Instrument and Combination Switches | 05 |
| 5.Keys | 07 |
| 6.Adjustment for the rear brake | 08 |
| 7. Inspection and adjustment for the transmission chain | 09 |
| 8.ARE YOU READY ! | 10 |
| 9.Basic Parameters | 12 |

1. Product Overview

Thank you for choosing our company as your electric bicycle brand. We wish you enjoy the comfort and joy it brings you in your long journey in the future!

Our company sincerely hopes that you can provide valuable feedback on the design, manufacturing, quality, and other aspects of this vehicle, and notify us on time in order to improve.

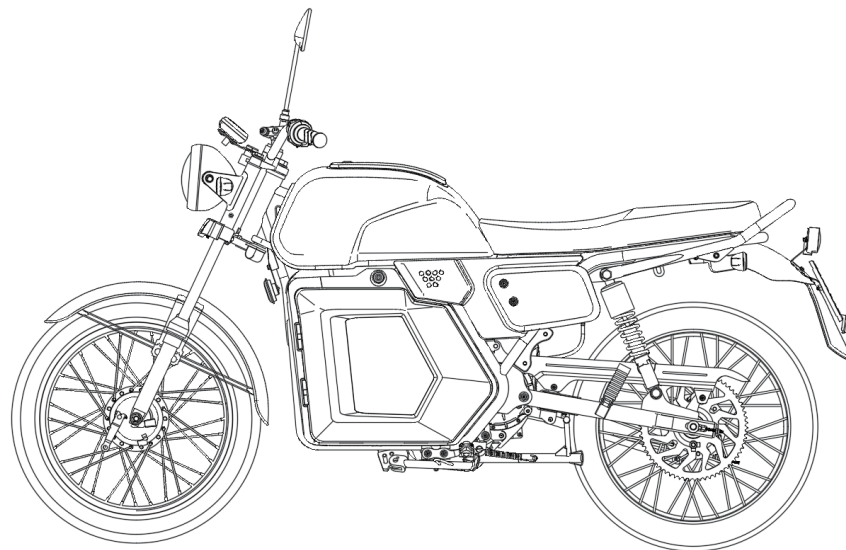

2. Operation Instruction

- Please fully understand the performance of this vehicle before use and ride safely.
- Please comply with local traffic regulations and refuse dangerous behaviors such as driving in the wrong direction, driving without following traffic lights, or using mobile phones while cycling.
- Do not disassemble our vehicles or disassemble parts on your own. Unauthorized disassembly and modification of vehicles is not allowed. If you need to replace parts, please purchase them from our company's electric bicycle general agent.

Please read the following content carefully for your and others' safety :

Matters need Attention

- When the road is slippery, the braking distance will be extended, and the distance between vehicles should be appropriately increased to avoid Rear-end collision.
- When wading in water and the water level reaches the Battery box level, it will cause a short circuit and damage to the wiring inside our vehicles, please pay attention and do avoid it.

Precautions for Vehicle Storage

- Please do not charge electric bicycles indoors, try to charge them at an outdoor charging station.
- When replacing the charger, it should match the battery model and try to use the original charger.

3. Parts Description

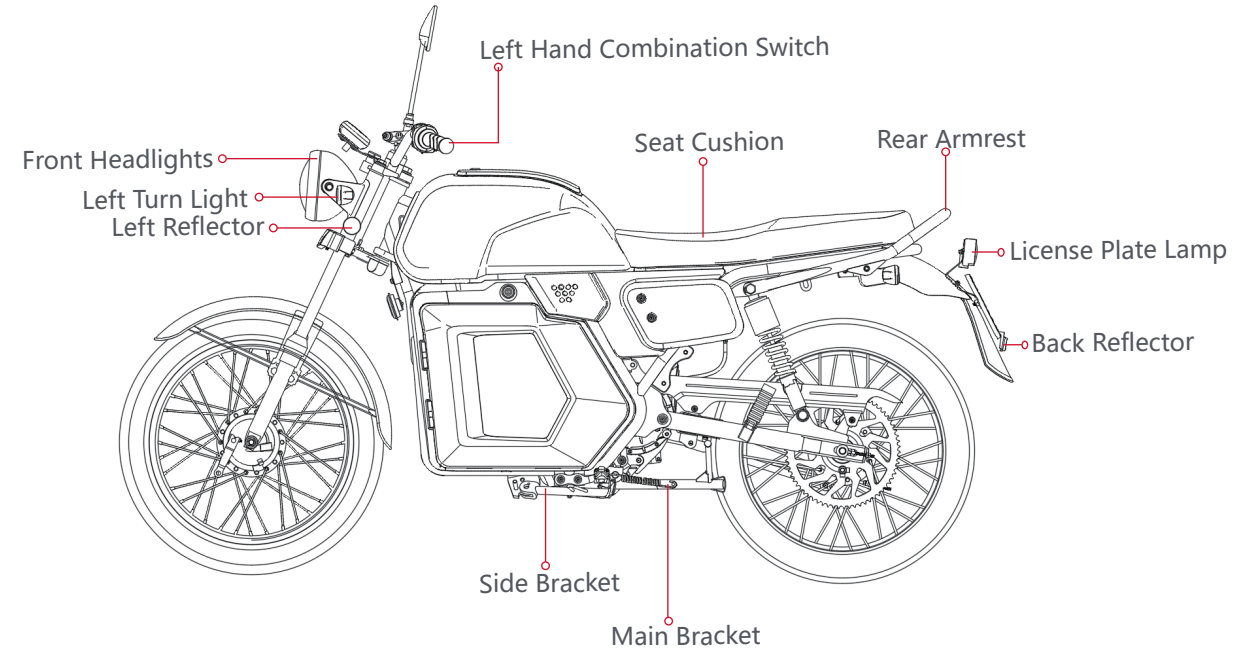

4. Instrument and Combination Switches

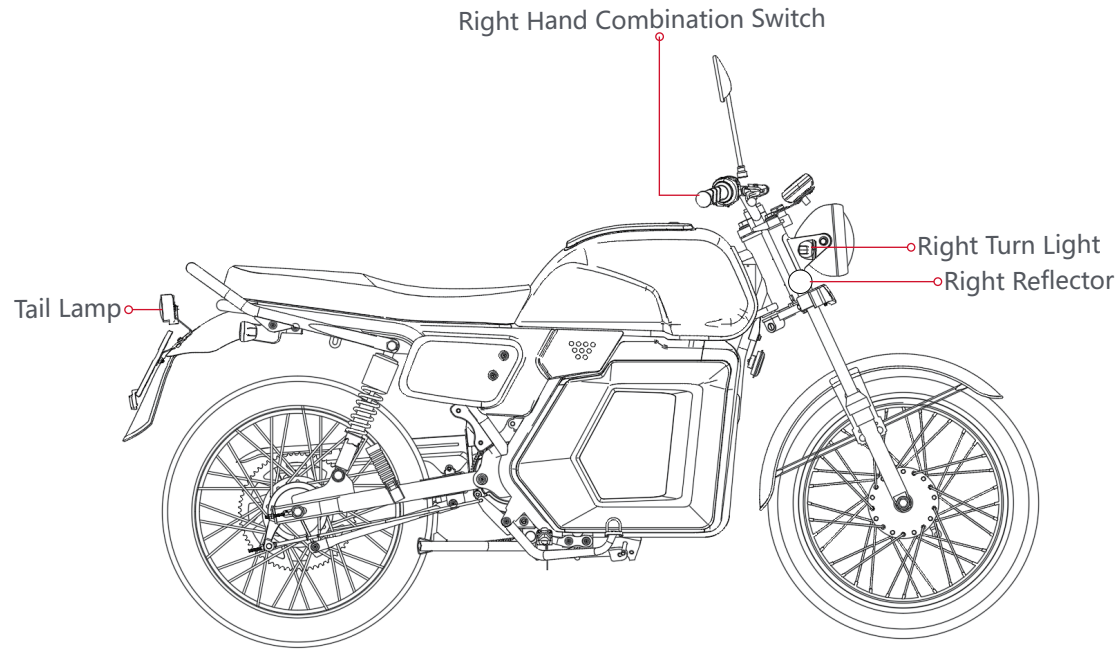

| | | | | | |
|-------|---|------------|---|------------------------|---|
| ← | Left Turn Signal Light | ⚠ | Signal Light for Brake Turn on when brake | 188 km/h | ECO Power saving 45km/h |
| D | High Beam | SIDE STAND | Side Bracket Light On when side stand work | Speed | NORMAL Normal 60km/h |
| READY | Ready to go | → | Right Turn Signal Light | Power Real-Time Values | SPORT Sports 85km/h |
| 🔥 | High Temperature Warning Light When battery/controller temperature exceeds 58 degrees, this symbol will light up | | | | TRIP 188888 km Subtotal mileage |
| | | | | | ODO 188888 km Total Mileage Traveled |

Combination Switches Instruction

Left Hand Combination Switches



Low/High Beam

Press to turn on low beam, then press again to switch to high beam;

Turn Signal

Slide the button to left, the left turn signal light on, press the button in the middle, can cancel the signal light;

Slide the button to right, the right turn signal light on, press the button in the middle, can cancel the signal light.



Horn

Press the horn button, the horn will sound, release to stop.



Park Gear

In P gear, simultaneously grip the brake (with a speed of 0)

Right Hand Combination Switches

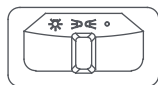

Contour lamp/headlight

Slide the button to the right, all lights will be turned off;

Slide the button to the middle, the contour light is turned on;

Slide the button to the left, Can use the left handle High beam and low beam switch to control and switch on the high beam and low beam.



Gear + and -

Press the left button to decrease the gear;

Press the right button to increase the gear position.

5. Keys

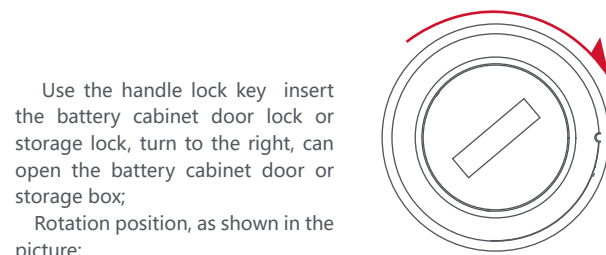
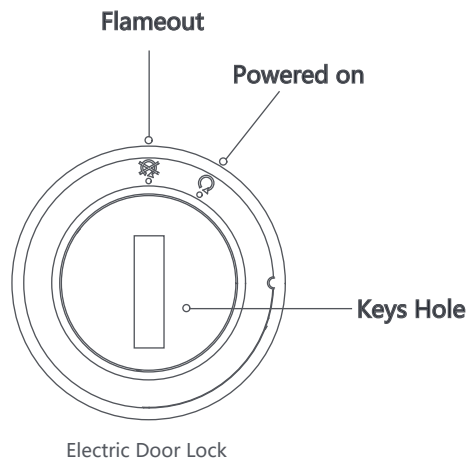

battery cabinet door lock/storage lock

6. Adjustment for the rear brake

1.The effectively moving range of the rear brake lever is within 20-30mm. Once it is out of the range , please adjust it at once.

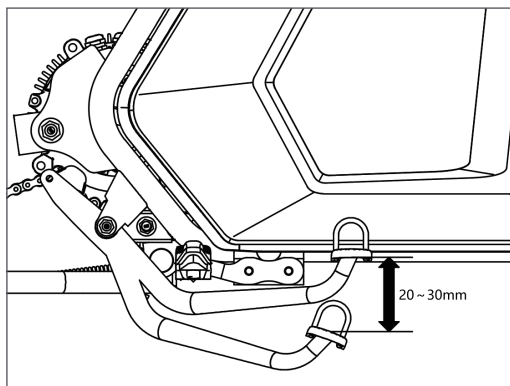

When adjusting, please turn the adjusting nut to the right direction to reduce the moving clearance ; otherwise the clearance will be increased.

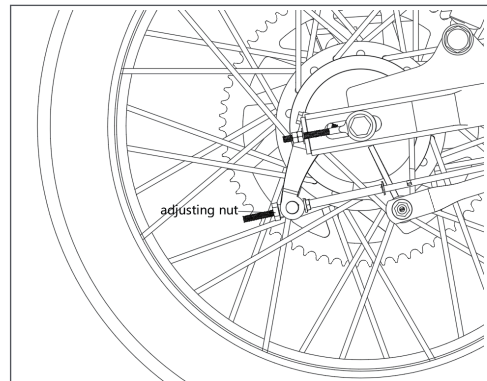

7. Inspection and adjustment for the transmission chain

1.If the drive chain has been used for a long time, it will be lengthened and loosen even reach the chain case and make noise. You must check and adjust it.

2.Adjust vertically the chain between the two chain wheels, the max amplitude of moving the chain is within 10~20mm(Fig.1)

3.When adjusting, Please loose the vehicle axle nut ①, and then turn the adjusting nut ②,to keep the chain adjustors on left and right side positioning the same graduation ②.After inspection, please tighten the locking nut, (The torque of the vehicle axle nut: 80-100N.m)(Fig2)

4.In order to protect the chain, you had better clean and lubricate it periodically.

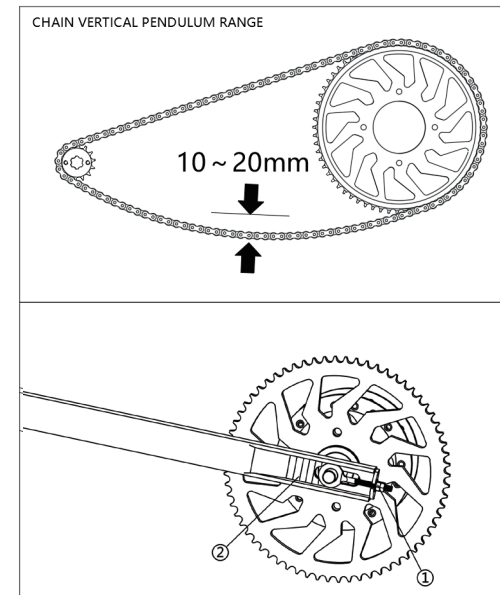

8. ARE YOU READY?

A simple three step preparation to complete a comfortable journey.

First

Please wear a safety helmet and sit on the vehicle, and turn the power lock to activate the vehicle's power supply.

Second

Please fold up the single support/double support and press the right hand combination key "P" while braking to release the lock of gear P. At this time, "READY" will appear in the instrument.

Third

Gently twist the throttle handle with your right hand and enjoy your first driving experience with your car.

Before driving, the vehicle condition should be checked, generally including the following items:

- Instrument: When the vehicle is powered on, please check if the instrument panel displays normally;
- Lights and horns: Check if all lights are in good condition and if the horns are functioning properly ;
- Tires: Check tire pressure and tire wear;
- Steering device: convenience and stability of operation;
- Battery: Open the battery cabinet and check if the appearance of the battery is good, ensuring that there are no obvious phenomena such as damage, leakage, heating, soaking in water, and smoking.

9. Basic parameters

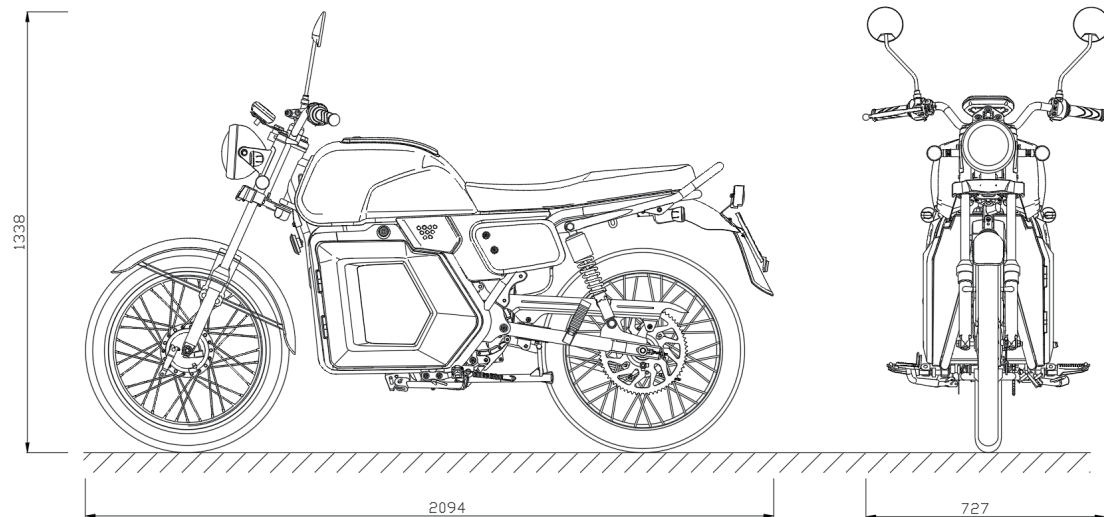

Vehicle Main Parameters

| No. | Description | Parameters |
|------|---|---------------------|
| A1 | Vehicle main parameters | |
| A1.1 | External dimensions: long × wide × high | 2094mm×727mm×1338mm |
| A1.2 | Seat height | 810mm |
| A1.3 | Motor | Mid Drive Motor |
| A1.4 | Controller | FOC |
| A1.5 | Battery | |
| A2 | Appearance dimensions | |
| A2.1 | Front hub | 1.4×18 |
| A2.2 | Rear hub | 1.6×18 |
| A2.3 | Front tire size | 2.5-18 |
| A2.4 | Rear tire size | 2.75-18 |
| A2.5 | Wheelbase | 1386 mm |
| A2.6 | Ground clearance | 190 mm |
| A2.7 | Technically permissible maximum load | 195kg |
| A2.8 | Wheel hub material | Aluminum+Steel |
| A3 | Technical specifications | |
| A3.1 | Rated power | 4.5kw |
| A3.2 | Top speed | 85 KM/H |
| A3.3 | Brake system | Drum |
| | | |
| | | |
| | | |