



DUCTWORK MADE EASY



Constructed with 16-gauge galvanized body; 14-gauge blades & cone

Spark Trap

DESCRIPTION

Our Spark Trap tumbles grinding sparks and embers through a torturous path giving them time to burn out before exiting. Due to this patented design, there are no space requirements between the spark trap and the dust collector.

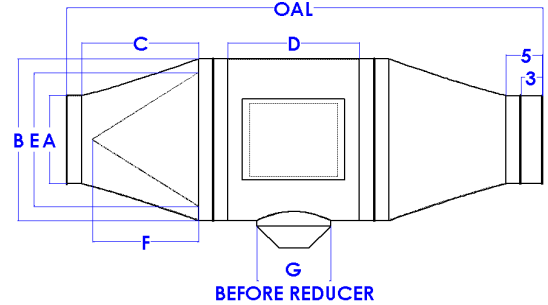

Dropout sizes 6" or greater include reducer

Inlet	Body	Inlet Length	Body Length	Cone Diam.	Cone Length	Dropout Diam.	Overall Length ***	CFM @ 3500 FPM
4	8	6.4	12	6	5.75	4	40	305
6	10	6.4	12	8	5.75	4	40	687
8	14	9.6	14	11	8.75	6*	48	1222
10	18	12.8	15	14	11.5	8*	56	1909
12	22	16	18	17	14.5	10**	65	2749
14	24	16	21	20	14.5	10**	68	3742
16	28	19.2	24	22	17.25	10**	77	4887
18	32	22.4	28	26	20	14**	88	6185
20	34	22.4	30	28	20.25	14**	90	7636
22	38	25.6	34	32	23	14**	100	9239
24	42	28.8	36	34	26	18**	109	10996
26	46	32	38	37	28.75	18**	117	12905
28	48	32	42	40	28.75	18**	121	14966
30	52	35.2	46	42	31.75	18**	131	17181
32	56	38.4	48	46	34.5	18**	140	19548
34	60	41.6	52	48	37.5	18**	150	22068
36	62	41.6	54	50	37.5	18**	152	24740
38	66	44.8	56	54	40.25	18**	161	27565
40	70	48	58	56	43.25	18**	169	30543
42	74	51.2	60	58	46	18**	177	33674
44	76	51.2	62	62	46	18**	179	36957
46	80	54.4	64	64	49	18**	188	40393
48	84	57.6	66	68	51.75	18**	196	43982
50	88	60.8	68	70	54.75	18**	205	47724

*Includes Reducer to 4" Hose for Collection Barrel

**Includes Reducer to 6" Hose for Collection Barrel

***Overall length will vary slightly depending on requested end conditions and variations in stock items; +/- 1". Length based on average width of connections at 2".

STATIC PRESSURE RATINGS

Velocity (FPM)	Static Pressure (WC)
3000	2.1
3200	2.5
3500	3.5

